



TECHNICAL GUIDE

**SINGLE PACKAGE
HEAT PUMP/ELECTRIC HEAT
14 SEER – R-410A – 1 PHASE
2 TO 5 NOMINAL TONS - 208/230 V
MODELS: PHE4*24 TO 60**



Due to continuous product improvement, specifications are subject to change without notice.

Visit us on the web at

www.simplygettingthejobdone.com and
www.york.com

Additional rating information can be found at
www.ahridirectory.org

WARRANTY SUMMARY*

Extended 10-Years limited parts and compressor warranty

* Extended warranty requires online registration within 90 days of purchase for replacement or closing for new home purchase. See limited warranty certificate in User's Information Manual for details.

DESCRIPTION

These packaged cooling/heating heat pumps are designed for outdoor installation. Only utility and duct connections are required at the point of installation.

FEATURES

- **Operating Efficiency** - All PHE4 heat pump models are rated at 14.0 SEER, 11.0 EER, and 8.0 HSPF for cooling and heating operation.
- **On-Site Flexibility** - All model sizes use a compact design cabinet in one of two footprints. This provides installer flexibility for placing the proper capacity unit on curbs or pads with the smallest footprint after the internal load has been determined. Field convertible duct connections from side shot to down shot allow the installer to have greater flexibility with less inventory.
- **Lower Installation Cost** - Installation time and costs are reduced by easy power and control wiring connections. The small base dimension means less space is required on the ground or roof. All units are completely wired, charged with R-410A refrigerant, and tested before shipment. Test stations using a state-of-the-art computerized process system are used to ensure product quality. Refrigerant charge and component part numbers are verified using computers during assembly. Vital run test statistics such as system pressure, motor currents, air velocity and temperature, unit vibration, and gas system safeties are monitored and recorded by the system to ensure unit performance. Equal size side supply and return duct connections allow easy connection of ducts to match low crawl spaces without transition pieces.
- **Utility Connections Made Easy** - Electric utility access is provided through the bottom or the side of the unit. Utility connections can be made quickly and with a minimum amount of field labor. A field supplied and field installed electrical disconnect switch must be installed.
- **Convertible Airflow Design** - The bottom duct openings are covered when they leave the factory, ready to be used for a side supply/side return application. If a bottom supply/bottom return application is required, remove the two panels from the bottom of the unit and place them in the side supply/side return duct openings. No panel cutting is required and no accessory panel is necessary. Convertible airflow design allows maximum field flexibility and minimum inventory.
- **Condensate Pan** - A corrosion-resistant, long-lasting, water-tight pan is positioned below the indoor coil to collect and drain all condensate, preventing build-up of stagnant condensate. The condensate pan conforms to ASHRAE 62-89 standards (Ventilation for Acceptable Indoor Air Quality).
- **Condensate Drain** - The 3/4 in. NPT female connection is rigidly mounted to ensure proper fit and leak tight seal.
- **Durable Finish** - The cabinet is made of G90 galvanized steel with a powder paint coating for appearance and protection. The pre-treated galvanized steel provides a better paint-to-steel bond, which resists corrosion and rust creep. Powder paint finish ensures less fading when exposed to sunlight, and provides superior corrosion resistance (1000 hour salt spray tested).

Continued on next page.

- **Full Perimeter Base Rails** - The easily removable base rails provide a solid foundation for the entire unit and protect the unit during shipment. The rails provide forklift access from all sides, and rigging holes are also provided so an overhead crane can be used to place the units on a roof. On applications where the unit is placed on a pad, the base keeps the unit off the pad to deter corrosion. On applications where height is limited, the base rails can be removed by removing two screws in each corner.
- **Attractive Appearance** - A single-piece top cover containing a top-discharge outdoor fan arrangement requires less square footage on installation and provides a wider variety of installations. The one-piece design adds greater water integrity. Rounded corners with water drip edges add to the attractive appearance and provide cut protection to the installer.
- **Top Discharge** - The top-discharge outdoor fan does not disrupt neighboring areas or dry out vegetation surrounding the unit. The warm air from the top mounted fan is blown up and away from the structure and any landscaping.
- **Outdoor Coil Grille** - All models use a stamped slotted design that provides superior impact protection against small objects during transit and after installation.
- **Low Operating Sound Level** - The upward airflow carries the normal operating noise up and away from the living area. The rigid top panel effectively isolates noise. Isolator mounted compressor and the rippled fins of the outdoor coil muffle the normal fan motor and compressor operating sounds. The unique formed base pan also aids in sound attenuation with its structural design.
- **Low Maintenance** - Long life, permanently lubricated outdoor and indoor fan motor bearings need no annual maintenance, adding greater reliability to the unit. Slide-out blower assembly and indoor coil assembly can be easily removed for cleaning or service.
- **Fan System** - All models operate over a wide range of design conditions with a standard ECM indoor fan motor. These units easily match all types of applications and provide greater on-site flexibility to match comfort requirements. The cooling speed and heating speeds are factory set at test design conditions but can be field adjusted. This allows maximum comfort capabilities.
- **Loss of Charge Switch** - All models include a loss of charge switch to provide safe shutdown of the compressor.
- **Simple Control Circuit** - A printed circuit board contains a status/diagnostic indicator light. Field thermostat wiring connects to color coded leads using twist on wire connections. Cooling controls use contactor and relays for simple application and troubleshooting. MATE-N-LOK plug connectors are used. The electrical control box is not located in the compressor compartment. The controls are mounted to allow the separate access panel to be removed for troubleshooting and maintenance without affecting the normal system operating pressures. All wiring internal to the unit is color/number coded.
- **Protected Compressor** - The compressor is internally protected against high pressure and temperature. This is accomplished by the simultaneous operation of scroll bypass and a temperature thermal overload sensor, which protects the compressor if undesirable operating conditions occur.
- **Pressure Switches** - A high pressure switch is standard in all units. When abnormal conditions are sensed through the pressure switch, the unit locks out, preventing any further operation until it is reset or the problem is corrected.
- **Exclusive Coil Design** - Grooved copper tubes and enhanced aluminum fin construction improve heat transfer for maximum efficiency and durability. Indoor coils use tin-coated copper tubing with aluminum fins for effective heat transfer.
- **Electric Heat** - All electric heat models use 6HK electric heat, which is available in 208/230-1-60 from 2 kW to 25 kW. Most kits are stageable above 10 kW. Single-phase single-point field wiring kits are available for all applications except 25 kW.
- **Easy Service Access** - Individual access panels provide access to all major components, for example, compressors, indoor coils, blowers, controls/electric heat kits, and filters, making servicing easy. Removing these panels allows easy removal of components such as the blower assembly for maintenance and troubleshooting.
- **Replacement Parts** - The installer requires no special training to replace any of the components of these units. The number of new components has been reduced to minimize the inventory of unique parts.
- **Controls** - Demand defrost curves preloaded into defrost control for optimized performance based on unit capacities.

NOMENCLATURE

PHE	4	A	24		2		1	A
1	2	3	4	5	6	7	8	9
1. Model Family PHE - packaged heat pump with electric heat PCG - packaged A/C with gas heat PHG - packaged heat pump with gas heat PCE - packaged A/C with electric heat 2. Nominal Cooling Efficiency 4 = 14 SEER, 6 = 16 SEER 3. Cabinet Size A = small 35 x 51, B = large 45 x 51 4. Nominal Air Conditioning Cooling Capacity BTUx1000 24 = 24,000 BTU, etc. Examples: PHE4B4221A is a packaged heat pump, 14 SEER, large cabinet, 3-1/2 ton, 230 V, single-phase model, first generation, first release.					5. Gas Heating Input BTU/Hr x 1000 050 = 50,000 BTU/Hr. input, blank = electric heat 6. Voltage-Phase-Frequency 2 = 208/230-1-60, 3 = 208/230-3-60, 4 = 460-3-60 7. NOx Approval X = low-NOx, blank = not low-NOx 8. Generation Level 1 = first generation 9. Revision Level A = original release, B = second release			

COMPONENT LOCATION

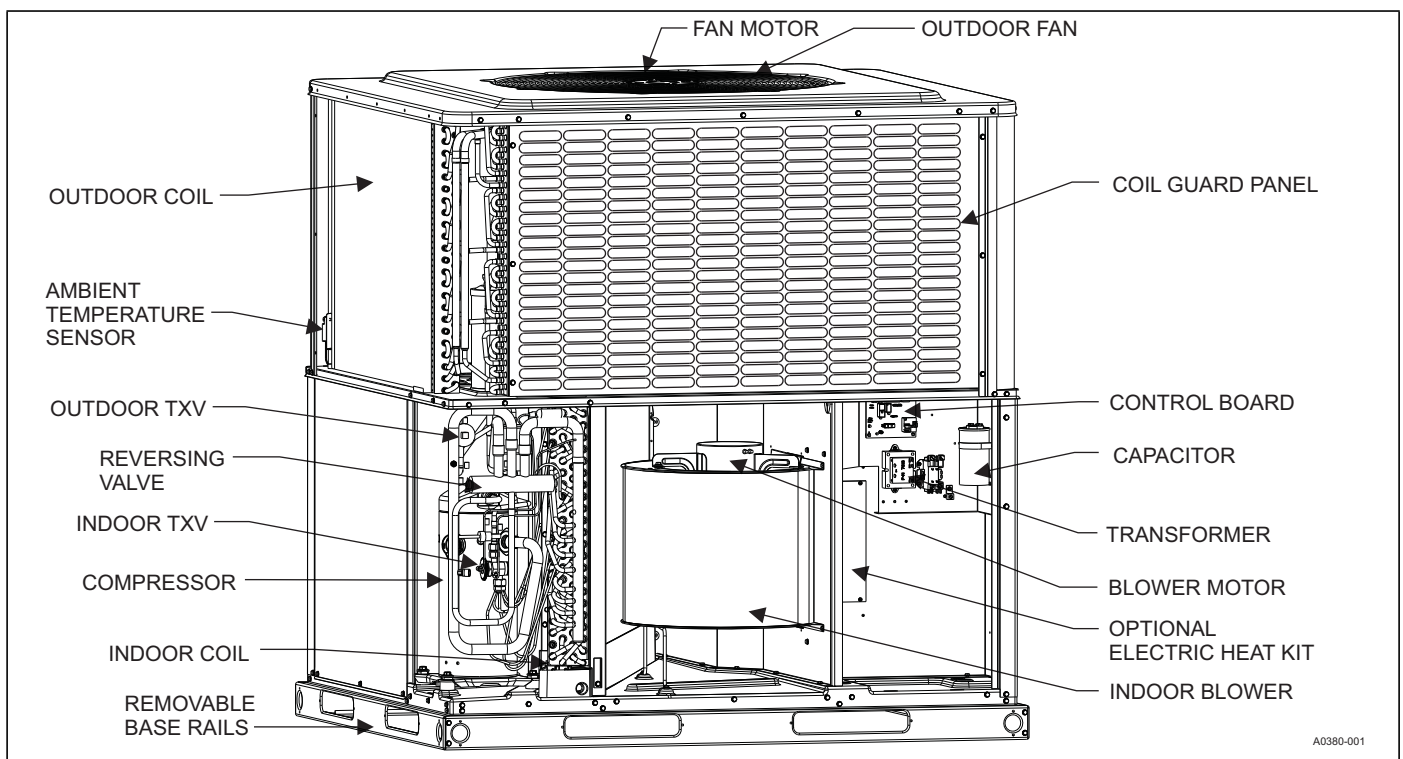

UNIT LIMITATIONS

Model	Unit Voltage	Unit Limitations		
		Applied Voltage		Outdoor DB Temperature
		Minimum	Maximum	Maximum (°F)
PHE4A2421	208/230-1-60	187	252	125
PHE4A3021	208/230-1-60	187	252	125
PHE4B3621	208/230-1-60	187	252	125
PHE4B4221	208/230-1-60	187	252	125
PHE4B4821	208/230-1-60	187	252	125
PHE4B6021	208/230-1-60	187	252	125

APPLICATIONS AND ACCESSORIES

Application Limitations								
Packaged Equipment Series	Air Temperature at Outdoor Coil (°F)				Air Temperature at Indoor Coil (°F)			
	Minimum		Maximum		Minimum		Maximum	
	DB Cool	DB Heat	DB Cool	DB Heat	WB Cool	WB Heat	WB Cool	WB Heat
14 SEER HP	55	-10	125	75	57	50	72	80

- **Anchor Bracket Kit (S1-1HK0601)** - This kit firmly anchors PCG, PCE, PHE, and PHG packaged units to a pad or support structure. When properly installed, the kit is approved for ground-mounted or roof-mounted applications, wind load certified, and listed with the State of Florida. See <https://floridabuilding.org> for this listing.
- **Economizer for Downflow Applications (S1-2EE04710024, S1-2EE04710124)** - Modulating integrated economizer provides simultaneous operation between mechanical cooling and economizer operation. Independent blade design ensures proper control and less than 1% leak rate. Includes hood and mesh bird screen filter integrated into the hood, dry bulb sensor, and barometric relief damper. Separate field accessories of single/dual enthalpy kits are also available.
- **Economizer for Horizontal Applications (S1-2EE04710224, S1-2EE04710324)** - Modulating integrated economizer provides simultaneous operation between the mechanical cooling and economizer operation. Independent blade design ensures proper control and less than 1% leak rate. Includes hood and mesh bird screen filter integrated into hood and dry bulb sensor. Separate field accessories of single enthalpy and dual enthalpy are available.
- **Barometric Relief Hood (S1-1RD0501)** - Used in conjunction with a horizontal economizer, the Barometric Relief Hood helps to equalize the building pressure caused by the fresh air that is introduced through the economizer fresh air hood.
- **Single/Dual Enthalpy Sensor (S1-HE-69630NS-2D)** - Sensor replaces dry bulb sensor standard in economizer kit. Provides improved economizer operation by sensing the dry bulb temperature from outdoors plus the enthalpy content of the outdoor air.
- **Duct/Unit Mount CO2 Kit (S1-2AQ04700924)** - Sensor kit detects CO2 levels automatically and overrides the economizer when CO2 levels rise above the preset limits.
- **Wall Mount CO2 Kit (S1-2AQ04701024)** - Sensor kit detects CO2 levels automatically and overrides the economizer when CO2 levels rise above the preset limits.
- **Supply Air Temperature Sensor Kit (S1-TE-63616E-2D)** - Outdoor supply air temperature sensor kit used with economizers.
- **Filter/Frame Kit (S1-1FF0602, S1-1FF0601)** - Kit contains the necessary hardware to field install return air filters into the base unit. The filter rack is suitable for 1 in. or 2 in. filters.
- **Filter (S1-02647812000)** - Washable 1 in. filter. Two filters are required for A base units. Three filters are required for B base units.
- **Motorized Fresh Air Damper (S1-2MD04705224, S1-2MD04705124)** - Designed for duct mounted side supply/return and unit mounted down supply/return applications. Damper capable of providing 0% through 50% of outdoor air (field supplied). Closes on power loss, and includes hood and screen assembly.

- **Rectangle to Round (Horizontal) Adapter (S1-1AK0110, S1-1AK0111)** - Kit includes one supply and one return air rectangle to round duct adapter. Adapters are preformed and designed to fit over current horizontal duct openings on the base unit. Transition is from rectangle to 12 in. round for the 1AK0110 kit and from rectangle to 14 in. round for the 1AK0111 kit.
- **Rectangle to Round (Downflow) Adapter (S1-1AK0108, S1-1AK0109)** - Kit includes one supply and one return air rectangle to round duct adapter. Adapters are preformed and designed to fit into current downflow duct openings on the roof curb. Transition is from rectangle to 16 in. round for the 1AK0108 kit and from rectangle to 18 in. round for the 1AK0109 kit.
- **Roof Curbs (S1-1RC0503, S1-1RC0501)** - NRCA approved curbs provide proper fit to base unit for rooftop installations. Curbs are designed to be assembled through hinge pins in each corner. Kit also provides seal strip to ensure an airtight seal. These are 8 in. high roof curbs.
- **Roof Curbs (S1-1RC0504, S1-1RC0502)** - NRCA approved curbs provide proper fit to base unit for rooftop installations. Curbs are designed for assembly through hinge pins in each corner. Kit also provides seal strip to ensure an airtight seal. These are 14 in. high roof curbs.
- **Transition Curb Kits (S1-1TC01*)** - Adapter kits to allow field use of pre-existing installed roof curbs to match PHE4 footprint to Affinity roof curbs, Carrier, Trane, or Goodman curb footprints. Curb adapters are optional for current generation Carrier replacements, but are recommended for previous generation applications. Refer to the PHE4 price pages for more details.
- **Manual Outdoor Damper (S1-1FA0502, S1-1FA0501)** - Provides 0% through 50% outdoor air capability (field adjustable). Designed for duct mounted side supply/return applications and unit mounted down supply/return applications. Includes hood and screen assembly.
- **Low Ambient Kit (S1-2LA04701024)** - Kit provides necessary hardware to convert unit to operate in cooling cycle down to 0°F. Standard unit operation 45°F.
- **Transformer Kit (S1-2EC06700124)** - Kit provides necessary hardware to provide single-phase models from factory furnished 40 VA transformer capability to 75 VA transformer capability. Required on installations with economizer or motorized damper.
- **Base Rail Hole Cover Kit (S1-1HC0101)** - Kit provides necessary hardware to close off openings in base rails to block off openings and prevent animal entrance.
- **Single Point Wiring Kits for 6HK Electric Heat Applications (S1-SPWK*)** - Kit provides field option for connecting electrical power supplies to the field installed 6HK kits to allow single-point connections for single-phase electric heat applications with the exception of 25 kW kits.
- **Thermostat** - Compatible thermostat controls are available through accessory sourcing. For optimum performance, these outdoor units are fully compatible with our residential Hx™ Touch Screen Thermostat available through Source 1. For more information, see the thermostat section of the Product Equipment Catalog.
- **Wall Thermostat** - The units are designed to operate with standard, 24 V electronic non power stealing and electromechanical thermostats. All units can operate with single-stage heat/single-stage cool thermostats - with or without the economizer.

* For additional kit numbers refer to the price pages.

GUIDE SPECIFICATIONS

GENERAL

Units shall be manufactured by Ducted Systems in an ISO 9001 certified facility. These packaged cooling/heating air conditioners are designed for outdoor installation. Only utility and duct connections are required at the point of installation. Heat pumps provide electric cooling and electric heating, with field installed electric heat kits from 5 kW to 25 kW for backup supplemental heating operation.

DESCRIPTION

Units shall be factory-assembled, single packaged, heat pumps with electric cooling/electric heating units, designed for outdoor installation. They shall have built-in, equal size, field convertible duct connections for downflow supply/return or horizontal supply/return. The units shall be factory wired, piped, and charged with R-410A refrigerant, and factory tested before shipment. All models shall be rated in accordance with DOE and AHRI test procedures for heating and cooling operation. Units shall be CSA listed to the UL 1995/CAN/CSA No. 236-M90 standards.

- **Operating Efficiency** - All heat pump models shall be rated at a minimum of 14.0 SEER, 11.0 EER, and 8.0 HSPF for cooling and heating operation.
- **Low Operating Sound Level** - The upward airflow carries the normal operating noise up and away from the living area. The rigid top panel effectively isolates noise. Isolator mounted compressor and the rippled fins of the outdoor coil muffle the normal fan motor and compressor operating sounds. The unique formed base pan also aids in sound attenuation with its structural design. Sound ratings as tested under AHRI test procedures shall be less than 77 db(A) for all models.

UNIT CABINET

Unit cabinet shall be a single piece design, with drip edges and no-seam corners to provide optimum water integrity. Unit shall have a rigidly mounted outdoor coil guard to provide protection from objects and personnel after installation. Indoor blower section shall be insulated with foil-faced or foam insulation, fastened to prevent insulation from entering the air stream. Cabinet panels shall be separate and easily removable for servicing and maintenance. Unit shall be built on a formed, design base pan, with embossments at critical points to add strength and rigidity and aid in minimizing sound. Full perimeter base rails shall be provided to ensure reliable transit of equipment and facilitate overhead rigging, allowing truck access and proper sealing on roof curb applications. Base rails shall be easily removable, when required to lower unit height. Filters shall be field installed, furnished, and accessible through a removable access door, sealed airtight. The unit's vertical discharge and return duct configuration shall be designed to fit between standard 24 in. O.C. beams without modification to building structure, duct work, and base unit.

- **On-Site Flexibility** - All model sizes shall use a compact design cabinet in one of two footprints. This provides installer flexibility for placing the proper capacity unit on curbs or pads with the smallest footprint after the internal load has been determined. Field convertible duct connections from side shot to down shot allow the installer to have greater flexibility with less inventory.

- **Durable Finish** - The cabinet shall be is made of G90 galvanized steel with a powder paint coating for appearance and protection. The pre-treated galvanized steel shall provide a better paint-to-steel bond, which resists corrosion and rust creep. The powder paint finish ensures less fading when exposed to sunlight, and provides superior corrosion resistance (1000 hour salt spray tested).
- **Attractive Appearance** - A single-piece top cover containing a top-discharge outdoor fan arrangement shall be used. This requires less square footage on installation and provides a wider variety of installations. The one-piece design adds greater water integrity. Rounded corners with water drip edges add to the attractive appearance and prevent water penetration.
- **Convertible Airflow Design** - The bottom duct openings are covered when they leave the factory, ready to be used for a side supply/side return application. If a bottom supply/bottom return application is required, remove the two panels from the bottom of the unit and place them in the side supply/side return duct openings. No panel cutting is required and no accessory panel is necessary. Convertible airflow design allows maximum field flexibility and minimum inventory.
- **Utility Connections Made Easy** - Electric utility access shall be provided through the bottom or the side of the unit. Utility connections should be made quickly and with a minimum amount of field labor. A field supplied and field installed electrical disconnect switch must be installed.
- **Easy Service Access** - Individual access panels provide access to all major components, for example, compressors, indoor coils, blowers, controls/electric heat kits, and filters, making servicing easy. Removing these panels allows easy removal of components such as the blower assembly for maintenance and troubleshooting.
- **Top Discharge** - The top-discharge outdoor fan does not disrupt neighboring areas or dry out vegetation surrounding the unit. The warm air from the top mounted fan is blown up and away from the structure and any landscaping.
- **Outdoor Coil Grille** - All models use a stamped slotted design that provides superior impact protection against small objects during transit and after installation.

Indoor Blower Assembly - Blower shall be direct drive design. Blower wheel shall be double-inlet type with forward-curved blades, dynamically balanced to operate smoothly throughout the entire range of operation. Design shall use constant torque motors. Bearings shall be sealed and permanently lubricated for longer life and no maintenance. Fan assembly shall be a slide-out design for easy removal and cleaning. Indoor blower motors shall be equipped with a standard high efficiency brushless DC motor (constant torque) also known as a standard ECM motor.

Outdoor Fan Assembly - The outdoor fan shall be of the direct-driven propeller type, discharge air vertically, have aluminum blades riveted to corrosion resistant steel spider bracket, and be statically balanced for smooth operation. The outdoor fan motor shall be totally enclosed with permanently lubricated bearings and internally protected against overload conditions.

REFRIGERANT COMPONENTS

- **Protected Compressor** - The compressor shall be a fully hermetic type, direct drive compressor, that is internally protected against high pressure and temperature. This is accomplished by the simultaneous operation of a scroll bypass valve and a temperature thermal overload sensor, which protects the compressor if undesirable operating conditions occur. The hermetic motor shall be suction gas cooled and have a voltage range of +/- 10% of the unit nameplate voltage. Compressors shall have internal isolation and sound muffling to minimize vibration and noise, and be externally isolated on a dedicated, independent mounting.
- **Indoor Coils** - Indoor coils shall be of the direct expansion, draw through design and have aluminum plate fins mechanically bonded to seamless internally enhanced tin-coated copper tubes with all joints brazed.
- **Condensate Pan** - A corrosion-resistant, long-lasting, water-tight pan is positioned below the indoor coil to collect and drain all condensate, preventing build-up of stagnant condensate. The condensate pan conforms to ASHRAE 62-89 standards (Ventilation for Acceptable Indoor Air Quality).
- **Condensate Drain** - The 3/4 in. NPT female connection is rigidly mounted to ensure proper fit and leak tight seal.
- **Outdoor Coils** - Outdoor coils shall have aluminum plate fins mechanically bonded to seamless internally enhanced copper tubes with all joints brazed, and be a draw through design.

Refrigerant Circuit and Refrigerant Safety Components shall include the following:

- Thermal expansion devices (TXVs) that are factory mounted and provided
- Filter/strainer to eliminate any foreign matter
- Reversing valves to control refrigerant flow

CONTROLS

- **Simple Control Circuit** - A printed circuit board contains a status/diagnostic indicator light. Field thermostat wiring connects to color coded leads using twist on wire connections. Cooling controls use contactor and relays for simple application and troubleshooting. MATE-N-LOK plug connectors are used. The electrical control box is not located in the compressor compartment. The controls are mounted to allow the separate access panel to be removed for troubleshooting and maintenance without affecting the normal system operating pressures. All wiring internal to the unit is color/number coded.
- **Controls** - Demand defrost curves pre-loaded into defrost control for optimized performance based on unit capacities.
- **Pressure Switches** - A high pressure switch is standard in all units. When abnormal conditions are sensed through the pressure switch, the unit locks out, preventing any further operation until it is reset or the problem is corrected.
- **Factory Testing** - Installation time and costs are reduced by easy power and control wiring connections. All units are completely wired, charged with R-410A refrigerant, and tested before shipment. Test stations using a state-of-the-art computerized process system shall be used to ensure product quality. Refrigerant charge and component part numbers are verified using computer bar code scans during assembly. Vital run test statistics such as system pressure, motor currents, air velocity and temperature, unit vibration, and gas system safeties are monitored and recorded by the system to ensure unit performance. This data could be provided by serial number tracking if necessary.
- **Electric Heat** - All electric heat models use 6HK electric heat, which is available in 208/230-1-60 from 2 kW to 25 kW. Most kits are stageable above 10 kW. Single-point accessory kits are available for single-phase models. Single-phase single-point field wiring kits are available for all applications except 25 kW. Electric heat kits must be certified to UL 1995 standard requirements.

PHYSICAL DATA

NOMINAL TONNAGE	MODELS					
	PHE4A2421	PHE4A3021	PHE4B3621	PHE4B4221	PHE4B4821	PHE4B6021
	2.0	2.5	3.0	3.5	4.0	5.0
AHRI Cooling Performance						
Gross Capacity @ AHRI A point (MBH)	24.1	30.1	36.4	42.3	48.2	59.9
AHRI net capacity (MBH)	23.8	29.6	35.8	41.5	47.0	58.0
EER	11.0	11.0	11.0	11.0	11.0	11.0
SEER	14.0	14.0	14.0	14.0	14.0	14.0
Nominal CFM	800	1000	1200	1400	1600	1800
System power (kW)	1.8	2.2	2.8	3.2	3.7	4.7
Refrigerant type	R-410A	R-410A	R-410A	R-410A	R-410A	R-410A
Refrigerant charge (lb-oz)	8-5	9-8	11-13	13-0	12-13	15-8
AHRI Heating Performance						
47°F Capacity Rating (MBH)	22.0	27.2	33.8	38.0	45.5	56.0
System Power (kW/COP)	3.7	3.6	3.6	3.6	3.7	3.6
17°F Capacity Rating (MBH)	12.0	14.8	19.6	22.0	26.0	32.0
HSPF (BTU/Watts-hr.)	8.0	8.0	8.0	8.0	8.0	8.0
Dimensions (in.)						
Length	51-1/4	51-1/4	51-1/4	51-1/4	51-1/4	51-1/4
Width	35-3/4	35-3/4	45-3/4	45-3/4	45-3/4	45-3/4
Height	47	49	49	49	53	55
Operating Weight (lb)	377	392	448	471	496	523
Compressors						
Type	Scroll	Scroll	Scroll	Scroll	Scroll	Scroll
Outdoor Coil Data						
Face area (sq. ft)	15.1	16.9	19.4	19.4	23.8	25.9
Rows	2	2	2	2	2	2
Fins per inch	22	22	22	22	22	22
Tube diameter	3/8	3/8	3/8	3/8	3/8	3/8
Circuitry Type	Interlaced	Interlaced	Interlaced	Interlaced	Interlaced	Interlaced
Refrigerant control	TXV	TXV	TXV	TXV	TXV	TXV
Indoor Coil Data						
Face area (sq. ft)	4.6	4.6	6.3	6.3	6.3	6.3
Rows	3	3	3	3	3	4
Fins per inch	16	16	16	16	16	16
Tube diameter	3/8	3/8	3/8	3/8	3/8	3/8
Circuitry Type	Interlaced	Interlaced	Interlaced	Interlaced	Interlaced	Interlaced
Refrigerant control	TXV	TXV	TXV	TXV	TXV	TXV
Outdoor Fan Data						
Fan diameter (in.)	24	24	26	26	26	26
Type	Prop	Prop	Prop	Prop	Prop	Prop
Drive type	Direct	Direct	Direct	Direct	Direct	Direct
Number of speeds	1	1	1	1	1	1
Motor HP each	1/10	1/8	1/3	1/3	1/3	1/3
RPM	850	850	850	850	850	850
Nominal total CFM	2400	2400	3200	3200	3200	3200
Direct Drive Indoor Blower Data						
Fan Size (in.)	11 x 8	11 x 8	11 x 10	11 x 10	11 x 10	11 x 10
Type	Centrifugal	Centrifugal	Centrifugal	Centrifugal	Centrifugal	Centrifugal
Motor HP each	1/2	1/2	1/2	3/4	3/4	1
RPM	1200 Max	1200 Max	1200 Max	1200 Max	1200 Max	1200 Max
Frame size	48	48	48	48	48	48
Filters						
Filter size	A	A	B	B	B	B
Quantity - Size	Field-supplied external filters must be sized so as not to exceed 300 fpm air velocity through disposable filters. For internal filter use, a filter rack kit is available. Consult the instructions supplied with that kit for replacement filter sizes. Filter sizes: A= 20 x 20, B = 20 x 30.					

COOLING PERFORMANCE DATA - 2 TON																	
PACKAGED UNIT MODEL NO.		PHE4A2421															
CONDENSER ENTERING AIR TEMPERATURE	ID CFM	600					800					1000					
		IDDB	80	80	75	80	80	80	80	75	80	80	80	80	75	80	80
		IDWB	57	62	62	67	72	57	62	62	67	72	57	62	62	67	72
55 / 45	T.C.	24.9	28.3	28.3	31.8	34.8	28.3	30.6	31.0	34.5	36.9	31.6	32.8	33.8	37.1	39.0	
	S.C.	23.5	19.9	18.0	17.8	15.0	26.5	23.4	20.7	20.2	16.1	29.5	26.8	23.4	22.6	17.1	
	K.W.	0.98	0.98	0.98	0.98	0.97	1.03	1.03	1.03	1.03	1.02	1.08	1.08	1.08	1.08	1.07	
65 / 55	T.C.	24.2	26.9	26.9	30.0	33.1	27.2	29.0	29.2	32.3	35.2	30.2	31.2	31.4	34.6	37.3	
	S.C.	22.5	19.2	17.0	16.9	14.1	25.3	22.6	19.6	19.4	15.4	28.1	26.0	22.2	22.0	16.8	
	K.W.	1.10	1.09	1.08	1.09	1.08	1.15	1.15	1.14	1.14	1.14	1.20	1.20	1.19	1.19	1.19	
75 / 63	T.C.	23.4	25.4	25.5	28.2	31.5	26.1	27.5	27.3	30.1	33.6	28.8	29.5	29.1	32.0	35.6	
	S.C.	21.5	18.5	16.1	16.0	13.2	24.2	21.9	18.5	18.7	14.8	26.8	25.2	21.0	21.4	16.4	
	K.W.	1.21	1.21	1.19	1.20	1.20	1.27	1.26	1.25	1.25	1.25	1.32	1.31	1.31	1.31	1.31	
85 / 69	T.C.	22.3	23.5	23.7	26.4	29.5	24.7	25.3	25.2	28.2	31.4	27.1	27.0	26.7	29.9	33.3	
	S.C.	20.4	17.7	15.2	15.1	12.4	22.8	20.7	17.4	17.6	14.0	25.1	23.7	19.6	20.2	15.5	
	K.W.	1.36	1.35	1.34	1.35	1.35	1.41	1.41	1.40	1.40	1.40	1.47	1.46	1.45	1.45	1.45	
95 / 75	T.C.	21.2	21.7	21.9	24.6	27.5	23.4	23.1	23.1	26.2	29.2	25.5	24.5	24.4	27.8	30.9	
	S.C.	19.4	16.8	14.4	14.3	11.6	21.4	19.5	16.3	16.6	13.1	23.4	22.1	18.2	18.9	14.7	
	K.W.	1.51	1.50	1.49	1.50	1.50	1.56	1.55	1.54	1.55	1.55	1.61	1.60	1.59	1.60	1.60	
105 / 83	T.C.	19.3	19.5	19.7	22.5	24.7	20.9	20.8	20.6	23.5	26.2	22.5	22.1	21.6	24.4	27.7	
	S.C.	17.8	15.9	13.2	13.4	10.5	19.4	18.2	15.2	15.5	11.9	21.0	20.4	17.1	17.6	13.3	
	K.W.	1.71	1.71	1.70	1.71	1.71	1.76	1.76	1.75	1.76	1.76	1.82	1.81	1.81	1.81	1.81	
115 / 89	T.C.	17.4	17.4	17.5	20.5	22.1	18.6	18.6	18.2	20.8	23.3	19.7	19.8	18.9	21.2	24.6	
	S.C.	16.2	15.1	12.2	12.5	9.5	17.5	16.9	14.1	14.4	10.7	18.7	18.8	16.1	16.2	11.9	
	K.W.	1.91	1.91	1.90	1.91	1.91	1.96	1.96	1.96	1.96	1.96	2.01	2.02	2.01	2.01	2.01	
125 / 95	T.C.	15.6	15.3	15.4	18.4	19.4	16.2	16.4	15.8	18.2	20.4	16.8	17.5	16.2	18.0	21.5	
	S.C.	14.7	14.3	11.1	11.6	8.5	15.5	15.7	13.0	13.2	9.5	16.4	17.1	15.0	14.9	10.5	
	K.W.	2.11	2.12	2.11	2.11	2.11	2.16	2.17	2.16	2.16	2.16	2.21	2.22	2.22	2.21	2.21	

COOLING PERFORMANCE DATA - 2.5 TON																	
PACKAGED UNIT MODEL NO.		PHE4A3021															
CONDENSER ENTERING AIR TEMPERATURE	ID CFM	800					1000					1200					
		IDDB	80	80	75	80	80	80	80	75	80	80	80	80	75	80	80
		IDWB	57	62	62	67	72	57	62	62	67	72	57	62	62	67	72
55 / 45	T.C.	30.3	33.5	33.8	37.2	42.9	32.8	35.3	35.8	39.4	45.4	35.3	37.2	37.8	41.6	47.9	
	S.C.	29.3	26.1	22.5	22.6	18.8	32.2	28.9	24.8	24.4	20.1	35.1	31.7	27.1	26.2	21.5	
	K.W.	1.50	1.50	1.50	1.50	1.51	1.50	1.50	1.50	1.50	1.51	1.50	1.50	1.51	1.51	1.51	
65 / 55	T.C.	29.0	31.7	31.8	35.6	39.8	31.2	33.5	33.7	37.6	42.7	33.4	35.4	35.5	39.6	45.5	
	S.C.	28.3	25.3	21.5	21.7	17.4	30.7	28.3	23.8	23.9	19.1	33.2	31.4	26.1	26.1	20.9	
	K.W.	1.66	1.66	1.66	1.67	1.67	1.66	1.66	1.66	1.67	1.67	1.66	1.66	1.67	1.67	1.68	
75 / 63	T.C.	27.6	29.9	29.9	34.0	36.8	29.6	31.7	31.5	35.8	40.0	31.5	33.6	33.2	37.6	43.2	
	S.C.	27.3	24.5	20.5	20.7	16.0	29.3	27.8	22.8	23.4	18.1	31.3	31.1	25.2	26.1	20.3	
	K.W.	1.82	1.83	1.82	1.84	1.84	1.82	1.83	1.82	1.84	1.84	1.83	1.83	1.83	1.84	1.85	
85 / 69	T.C.	25.6	28.1	27.5	31.6	35.0	27.4	29.5	28.9	33.1	37.4	29.1	30.9	30.3	34.7	39.8	
	S.C.	25.4	23.3	19.5	19.8	15.3	27.1	26.4	21.8	22.3	17.2	28.9	29.5	24.2	24.8	19.1	
	K.W.	2.02	2.03	2.02	2.04	2.04	2.03	2.03	2.03	2.04	2.05	2.03	2.03	2.03	2.04	2.05	
95 / 75	T.C.	23.6	26.4	25.2	29.2	33.2	25.2	27.3	26.3	30.5	34.8	26.7	28.1	27.4	31.8	36.5	
	S.C.	23.4	22.1	18.6	18.9	14.7	25.0	25.0	20.8	21.2	16.3	26.5	27.9	23.1	23.5	17.9	
	K.W.	2.23	2.23	2.23	2.24	2.25	2.23	2.23	2.23	2.24	2.25	2.24	2.24	2.23	2.24	2.25	
105 / 83	T.C.	21.1	22.9	22.1	26.0	29.6	22.6	23.8	22.8	27.1	30.8	24.0	24.6	23.6	28.2	32.1	
	S.C.	21.0	20.1	16.7	17.3	13.4	22.4	22.2	18.7	19.4	14.7	23.8	24.4	20.7	21.5	16.0	
	K.W.	2.52	2.51	2.51	2.53	2.54	2.52	2.52	2.51	2.53	2.54	2.53	2.53	2.51	2.53	2.54	
115 / 89	T.C.	18.7	19.6	19.0	22.8	26.1	20.0	20.4	19.4	23.7	27.0	21.3	21.1	19.9	24.6	27.9	
	S.C.	18.6	18.1	14.9	15.7	12.2	19.9	19.5	16.6	17.6	13.2	21.2	21.0	18.4	19.6	14.2	
	K.W.	2.80	2.79	2.79	2.80	2.81	2.80	2.80	2.79	2.80	2.81	2.81	2.80	2.79	2.80	2.81	
125 / 95	T.C.	16.3	16.2	16.0	19.7	22.6	17.5	16.9	16.1	20.4	23.1	18.7	17.7	16.1	21.1	23.6	
	S.C.	16.2	16.1	13.1	14.2	10.9	17.4	16.8	14.6	15.9	11.6	18.6	17.5	16.0	17.6	12.3	
	K.W.	3.08	3.07	3.07	3.08	3.09	3.08	3.07	3.07	3.08	3.09	3.09	3.08	3.07	3.08	3.09	

COOLING PERFORMANCE DATA - 3 TON																
PACKAGED UNIT MODEL NO.		PHE4B3621														
CONDENSER ENTERING AIR TEMPERATURE	ID CFM	1000					1200					1400				
	IDDB	80	80	75	80	80	80	80	75	80	80	80	80	80	80	80
	IDWB	57	62	62	67	72	57	62	62	67	72	57	62	62	67	72
55 / 45	T.C.	40.4	43.9	43.9	47.3	46.7	43.3	45.1	45.4	47.7	47.3	46.2	46.2	46.8	48.2	47.8
	S.C.	40.0	34.9	30.5	29.3	22.4	42.9	40.4	32.6	31.2	23.3	45.9	45.9	34.6	33.0	24.3
	K.W.	1.97	1.98	1.98	1.98	1.98	2.06	2.07	2.07	2.07	2.07	2.16	2.16	2.16	2.16	2.16
65 / 55	T.C.	37.9	41.2	41.4	45.1	47.2	40.4	42.4	42.6	46.0	47.8	42.8	43.7	43.8	46.9	48.5
	S.C.	37.9	33.7	29.1	28.4	22.3	40.4	38.1	32.7	30.6	23.5	42.8	42.5	36.4	32.7	24.7
	K.W.	2.17	2.18	2.17	2.18	2.18	2.26	2.27	2.27	2.28	2.28	2.36	2.36	2.37	2.37	2.37
75 / 63	T.C.	35.4	38.5	38.9	42.8	47.6	37.5	39.8	39.8	44.2	48.4	39.5	41.1	40.7	45.7	49.1
	S.C.	35.4	32.5	27.6	27.4	22.1	37.5	35.7	32.9	29.9	23.7	39.5	39.0	38.2	32.5	25.2
	K.W.	2.36	2.39	2.36	2.39	2.39	2.46	2.48	2.47	2.48	2.48	2.56	2.57	2.58	2.58	2.58
85 / 69	T.C.	33.1	35.4	35.8	39.7	44.4	34.7	36.5	36.6	40.7	45.2	36.4	37.5	37.4	41.6	46.0
	S.C.	33.1	30.8	26.1	25.9	20.7	34.7	34.0	30.0	28.2	22.3	36.4	37.1	33.9	30.6	23.9
	K.W.	2.63	2.65	2.63	2.65	2.65	2.72	2.74	2.73	2.74	2.74	2.81	2.83	2.83	2.83	2.83
95 / 75	T.C.	30.7	32.2	32.7	36.6	41.1	32.0	33.1	33.4	37.1	42.1	33.4	33.9	34.1	37.6	43.0
	S.C.	30.7	29.1	24.6	24.3	19.4	32.0	32.2	27.1	26.5	21.0	33.4	33.9	29.6	28.7	22.6
	K.W.	2.89	2.91	2.89	2.91	2.91	2.98	3.00	2.98	3.00	3.00	3.07	3.09	3.08	3.09	3.09
105 / 83	T.C.	27.8	28.4	28.7	32.2	36.6	28.8	29.1	29.0	32.3	37.1	29.8	29.7	29.3	32.5	37.5
	S.C.	27.8	26.7	22.7	22.5	17.6	28.8	28.8	24.6	24.6	19.0	29.8	29.7	26.5	26.8	20.5
	K.W.	3.26	3.28	3.27	3.28	3.28	3.35	3.37	3.36	3.37	3.37	3.44	3.46	3.45	3.46	3.46
115 / 89	T.C.	25.1	24.8	24.9	27.9	32.3	25.7	25.2	24.7	27.7	32.2	26.4	25.6	24.5	27.4	32.1
	S.C.	25.1	24.3	20.9	20.7	15.8	25.7	25.2	22.2	22.8	17.1	26.4	25.6	23.6	24.9	18.5
	K.W.	3.63	3.64	3.63	3.63	3.64	3.72	3.73	3.73	3.72	3.73	3.81	3.82	3.82	3.81	3.82
125 / 95	T.C.	22.3	21.1	21.1	23.7	27.9	22.6	21.3	20.5	23.0	27.3	22.9	21.5	19.8	22.4	26.8
	S.C.	22.3	21.1	19.0	18.9	14.1	22.6	21.3	19.8	21.0	15.3	22.9	21.5	19.8	22.4	16.4
	K.W.	3.99	4.00	4.00	3.99	4.00	4.08	4.09	4.09	4.08	4.09	4.17	4.18	4.18	4.17	4.18

COOLING PERFORMANCE DATA - 3.5 TON																
PACKAGED UNIT MODEL NO.		PHE4B4221														
CONDENSER ENTERING AIR TEMPERATURE	ID CFM	1200					1400					1600				
	IDDB	80	80	75	80	80	80	80	75	80	80	80	80	75	80	80
	IDWB	57	62	62	67	72	57	62	62	67	72	57	62	62	67	72
55 / 45	T.C.	45.8	50.4	50.3	53.3	55.3	47.6	51.3	51.2	54.1	56.6	49.5	52.3	52.1	54.9	57.9
	S.C.	45.8	40.4	34.5	33.0	25.6	47.6	42.5	36.2	34.4	26.5	49.5	44.6	37.9	35.9	27.4
	K.W.	2.26	2.27	2.28	2.28	2.28	2.37	2.37	2.37	2.38	2.38	2.47	2.47	2.46	2.47	2.47
65 / 55	T.C.	43.1	47.4	47.8	52.0	55.3	44.8	48.6	48.7	52.9	56.2	46.4	49.8	49.7	53.9	57.0
	S.C.	43.1	39.3	33.5	32.9	25.6	44.8	42.1	35.8	34.9	26.7	46.4	45.0	38.0	36.9	27.8
	K.W.	2.49	2.50	2.51	2.51	2.52	2.60	2.60	2.60	2.61	2.62	2.70	2.69	2.69	2.71	2.71
75 / 63	T.C.	40.3	44.4	45.3	50.7	55.4	41.9	45.8	46.3	51.8	55.8	43.4	47.3	47.3	52.9	56.2
	S.C.	40.3	38.2	32.6	32.7	25.5	41.9	41.8	35.3	35.3	26.8	43.4	45.4	38.1	37.9	28.2
	K.W.	2.72	2.73	2.73	2.74	2.76	2.82	2.82	2.82	2.85	2.86	2.93	2.92	2.92	2.95	2.95
85 / 69	T.C.	37.1	40.6	41.2	46.5	51.5	38.5	41.6	41.9	47.2	52.2	39.9	42.7	42.6	47.9	52.9
	S.C.	37.1	36.1	30.4	30.7	24.0	38.5	39.1	33.0	33.0	25.4	39.9	42.0	35.5	35.4	26.7
	K.W.	3.02	3.02	3.03	3.04	3.05	3.12	3.12	3.12	3.14	3.15	3.22	3.22	3.22	3.24	3.25
95 / 75	T.C.	34.0	36.8	37.2	42.4	47.6	35.2	37.5	37.6	42.7	48.6	36.5	38.1	38.0	43.0	49.7
	S.C.	34.0	34.1	28.3	28.7	22.5	35.2	36.4	30.6	30.8	23.9	36.5	38.1	32.9	32.9	25.3
	K.W.	3.31	3.31	3.33	3.35	3.35	3.41	3.41	3.42	3.44	3.45	3.51	3.51	3.51	3.53	3.55
105 / 83	T.C.	30.8	32.1	32.0	37.2	42.4	32.0	33.1	32.1	37.1	42.8	33.3	34.1	32.2	36.9	43.2
	S.C.	30.8	30.4	26.1	26.6	20.4	32.0	32.5	27.5	28.5	21.7	33.3	34.1	29.0	30.4	23.1
	K.W.	3.73	3.73	3.74	3.76	3.76	3.83	3.83	3.83	3.85	3.86	3.93	3.93	3.92	3.95	3.96
115 / 89	T.C.	27.7	27.5	27.0	32.2	37.4	28.9	28.8	26.8	31.6	37.1	30.1	30.1	26.6	31.0	36.9
	S.C.	27.7	26.9	24.0	24.7	18.4	28.9	28.7	24.5	26.3	19.7	30.1	30.1	25.1	28.0	20.9
	K.W.	4.13	4.14	4.14	4.16	4.17	4.23	4.24	4.23	4.25	4.26	4.33	4.34	4.32	4.35	4.36
125 / 95	T.C.	24.6	23.0	21.9	27.1	32.3	25.8	24.6	21.5	26.1	31.5	27.0	26.2	21.0	25.1	30.6
	S.C.	24.6	23.0	21.8	22.7	16.5	25.8	24.6	21.5	24.1	17.6	27.0	26.2	21.0	25.1	18.7
	K.W.	4.53	4.54	4.53	4.56	4.58	4.63	4.64	4.63	4.65	4.66	4.73	4.74	4.72	4.75	4.75

COOLING PERFORMANCE DATA - 4 TON																	
PACKAGED UNIT MODEL NO.		PHE4B4821															
CONDENSER ENTERING AIR TEMPERATURE	ID CFM	1400					1600					1800					
		IDDB	80	80	75	80	80	80	80	75	80	80	80	80	75	80	80
		IDWB	57	62	62	67	72	57	62	62	67	72	57	62	62	67	72
55 / 45	T.C.	48.0	51.3	52.4	56.5	64.4	50.6	53.7	54.5	60.0	66.5	53.1	56.1	56.7	63.6	68.5	
	S.C.	48.0	44.1	37.9	40.8	33.6	50.6	47.6	40.5	42.6	35.0	53.1	51.0	43.2	44.3	36.4	
	K.W.	2.63	2.64	2.63	2.66	2.70	2.77	2.77	2.77	2.80	2.82	2.91	2.90	2.90	2.93	2.95	
65 / 55	T.C.	45.0	48.1	48.9	54.0	60.8	47.3	50.1	50.9	56.8	62.7	49.7	52.0	53.0	59.5	64.7	
	S.C.	45.0	41.5	35.6	37.5	31.0	47.3	44.8	38.1	39.6	32.6	49.7	48.0	40.6	41.7	34.2	
	K.W.	2.90	2.92	2.90	2.94	2.96	3.03	3.05	3.03	3.07	3.09	3.17	3.17	3.16	3.21	3.22	
75 / 63	T.C.	42.0	44.9	45.4	51.6	57.2	44.1	46.4	47.3	53.5	59.0	46.2	47.9	49.3	55.4	60.8	
	S.C.	42.0	38.9	33.3	34.2	28.4	44.1	41.9	35.7	36.6	30.1	46.2	45.0	38.0	39.0	31.9	
	K.W.	3.16	3.21	3.16	3.22	3.22	3.30	3.32	3.30	3.35	3.35	3.43	3.44	3.43	3.48	3.49	
85 / 69	T.C.	39.3	41.4	41.9	48.2	53.7	41.1	42.8	43.5	49.9	55.3	42.9	44.1	45.2	51.7	56.8	
	S.C.	39.3	36.4	31.0	32.0	26.1	41.1	39.4	33.2	34.3	27.7	42.9	42.4	35.5	36.6	29.4	
	K.W.	3.53	3.56	3.52	3.57	3.58	3.66	3.68	3.65	3.70	3.72	3.79	3.81	3.79	3.84	3.85	
95 / 75	T.C.	36.6	37.9	38.5	44.8	50.1	38.1	39.1	39.7	46.4	51.5	39.7	40.4	41.0	48.0	52.9	
	S.C.	36.6	34.0	28.6	29.8	23.8	38.1	36.9	30.8	32.0	25.3	39.7	39.8	33.0	34.2	26.9	
	K.W.	3.91	3.91	3.87	3.93	3.95	4.03	4.04	4.01	4.06	4.08	4.16	4.17	4.15	4.19	4.20	
105 / 83	T.C.	33.2	34.2	34.7	41.0	46.0	34.4	35.4	35.9	42.2	47.3	35.7	36.5	37.0	43.4	48.6	
	S.C.	33.2	32.3	26.9	27.7	21.9	34.4	34.8	28.9	29.7	23.4	35.7	36.5	31.0	31.7	24.9	
	K.W.	4.40	4.40	4.38	4.43	4.44	4.53	4.53	4.51	4.56	4.57	4.66	4.66	4.64	4.69	4.70	
115 / 89	T.C.	29.9	30.7	31.1	37.3	42.1	30.8	31.7	32.1	38.1	43.3	31.8	32.8	33.1	38.9	44.4	
	S.C.	29.9	30.6	25.2	25.6	20.1	30.8	31.7	27.1	27.5	21.5	31.8	32.8	29.0	29.4	22.9	
	K.W.	4.89	4.89	4.87	4.91	4.92	5.02	5.01	5.00	5.04	5.05	5.15	5.14	5.12	5.17	5.18	
125 / 95	T.C.	26.5	27.1	27.5	33.6	38.2	27.2	28.1	28.3	34.0	39.2	27.9	29.0	29.1	34.4	40.3	
	S.C.	26.5	27.1	23.5	23.6	18.3	27.2	28.1	25.2	25.3	19.7	27.9	29.0	27.0	27.1	21.0	
	K.W.	5.37	5.37	5.36	5.39	5.40	5.50	5.49	5.48	5.52	5.53	5.64	5.62	5.60	5.65	5.66	

COOLING PERFORMANCE DATA - 5 TON																
PACKAGED UNIT MODEL NO.		PHE4B6021														
CONDENSER ENTERING AIR TEMPERATURE	ID CFM	1600					1800					2000				
		IDDB	80	80	75	80	80	80	75	80	80	80	80	75	80	80
		IDWB	57	62	62	67	72	57	62	62	67	72	57	62	62	67
55 / 45	T.C.	61.5	74.6	68.4	68.6	81.4	65.3	74.6	70.4	70.6	80.6	69.1	74.7	72.3	72.6	79.7
	S.C.	61.5	46.4	47.0	55.3	37.3	65.3	49.2	50.6	60.0	38.1	69.1	52.1	54.2	64.6	38.9
	K.W.	3.37	3.44	3.40	3.41	3.45	3.54	3.59	3.56	3.57	3.61	3.72	3.74	3.72	3.73	3.76
65 / 55	T.C.	58.9	66.6	64.2	67.4	77.8	62.3	64.4	65.8	69.2	78.2	65.6	62.1	67.4	71.1	78.5
	S.C.	58.9	48.4	45.0	49.0	36.9	62.3	48.6	48.5	53.0	37.8	65.6	48.7	52.0	57.1	38.8
	K.W.	3.69	3.75	3.74	3.77	3.82	3.87	4.06	3.90	3.93	3.98	4.05	4.37	4.06	4.10	4.14
75 / 63	T.C.	56.3	58.7	60.0	66.2	74.3	59.2	54.1	61.2	67.8	75.8	62.1	49.5	62.5	69.5	77.3
	S.C.	56.3	50.4	42.9	42.6	36.5	59.2	47.9	46.4	46.1	37.6	62.1	45.4	49.8	49.5	38.7
	K.W.	4.01	4.06	4.09	4.14	4.18	4.20	4.53	4.25	4.30	4.35	4.39	5.01	4.41	4.47	4.52
85 / 69	T.C.	52.5	54.1	55.0	61.5	69.1	55.1	52.4	56.2	62.7	70.5	57.8	50.6	57.4	63.9	72.0
	S.C.	52.5	47.9	40.8	40.5	33.4	55.1	48.3	44.1	43.8	34.8	57.8	48.6	47.3	47.1	36.2
	K.W.	4.49	4.53	4.54	4.60	4.64	4.67	4.85	4.70	4.76	4.81	4.85	5.17	4.87	4.93	4.97
95 / 75	T.C.	48.6	49.5	50.0	56.7	63.8	51.1	50.6	51.2	57.5	65.3	53.5	51.7	52.4	58.3	66.7
	S.C.	48.6	45.4	38.8	38.4	30.2	51.1	48.6	41.8	41.6	32.0	53.5	51.7	44.8	44.8	33.8
	K.W.	4.97	5.01	4.99	5.05	5.10	5.14	5.17	5.15	5.22	5.26	5.31	5.33	5.32	5.39	5.42
105 / 83	T.C.	44.5	44.3	44.1	50.1	57.4	46.5	45.1	44.7	50.2	58.2	48.6	46.0	45.4	50.3	59.1
	S.C.	44.5	41.6	35.9	36.5	27.7	46.5	43.9	38.2	39.0	29.4	48.6	46.0	40.4	41.4	31.1
	K.W.	5.66	5.68	5.66	5.71	5.75	5.83	5.84	5.82	5.88	5.91	5.99	6.00	5.99	6.04	6.07
115 / 89	T.C.	40.5	39.2	38.4	43.6	51.1	42.1	39.9	38.5	43.0	51.4	43.8	40.5	38.6	42.5	51.7
	S.C.	40.5	37.9	33.2	34.6	25.2	42.1	39.3	34.7	36.4	26.9	43.8	40.5	36.2	38.1	28.5
	K.W.	6.33	6.34	6.31	6.35	6.39	6.49	6.50	6.47	6.52	6.55	6.66	6.66	6.63	6.68	6.71
125 / 95	T.C.	36.5	34.1	32.7	37.1	44.9	37.7	34.6	32.3	35.9	44.6	39.0	35.0	31.8	34.8	44.3
	S.C.	36.5	34.1	30.4	32.8	22.8	37.7	34.6	31.2	33.8	24.4	39.0	35.0	31.8	34.8	25.9
	K.W.	7.00	6.99	6.97	6.99	7.02	7.16	7.15	7.12	7.16	7.18	7.32	7.31	7.28	7.32	7.34

HEATING PERFORMANCE DATA - 2 TON										
PACKAGED UNIT MODEL NO.		PHE4A2421								
AIR TEMP. ENTERING OUTDOOR COIL	AIR TEMP. ENTERING INDOOR COIL	ID CFM								
		600			800			1000		
		MBH	COP	KW	MBH	COP	KW	MBH	COP	KW
60	60	28.1	4.56	1.80	29.3	5.06	1.69	30.5	5.63	1.58
	70	26.7	3.92	1.99	27.8	4.34	1.87	29.0	4.82	1.76
	80	25.3	3.39	2.18	26.4	3.75	2.05	27.5	4.16	1.93
47	60	23.4	4.00	1.71	24.1	4.31	1.63	24.9	4.66	1.56
	70	22.3	3.42	1.91	23.0	3.70	1.82	23.7	4.00	1.73
	80	21.3	2.96	2.10	21.9	3.20	2.00	22.5	3.46	1.90
40	60	20.7	3.61	1.67	21.4	3.87	1.61	22.0	4.16	1.54
	70	19.8	3.09	1.87	20.4	3.32	1.79	21.0	3.58	1.71
	80	18.8	2.66	2.06	19.4	2.87	1.97	20.0	3.10	1.88
30	60	17.1	3.08	1.62	17.6	3.28	1.57	18.2	3.48	1.53
	70	16.7	2.69	1.80	17.0	2.83	1.75	17.3	2.98	1.69
	80	16.2	2.38	1.99	16.3	2.47	1.93	16.4	2.57	1.86
17	60	13.6	2.57	1.54	13.9	2.65	1.52	14.1	2.75	1.50
	70	12.7	2.14	1.73	12.9	2.22	1.69	13.1	2.31	1.66
	80	11.8	1.80	1.91	12.0	1.87	1.87	12.2	1.95	1.82
10	60	12.2	2.36	1.51	12.1	2.37	1.49	12.1	2.38	1.48
	70	11.4	1.97	1.68	11.3	1.99	1.66	11.3	2.01	1.63
	80	10.5	1.65	1.86	10.4	1.67	1.82	10.4	1.70	1.79

HEATING PERFORMANCE DATA - 2.5 TON										
PACKAGED UNIT MODEL NO.		PHE4A3021								
AIR TEMP. ENTERING OUTDOOR COIL	AIR TEMP. ENTERING INDOOR COIL	ID CFM								
		800			1000			1200		
		MBH	COP	KW	MBH	COP	KW	MBH	COP	KW
60	60	34.6	4.82	2.10	35.6	5.05	2.06	36.6	5.29	2.02
	70	33.3	4.19	2.32	34.2	4.40	2.27	35.0	4.62	2.22
	80	32.0	3.67	2.55	32.8	3.86	2.48	33.5	4.05	2.41
47	60	29.1	4.13	2.06	29.6	4.27	2.03	30.1	4.41	1.99
	70	27.7	3.55	2.27	28.2	3.68	2.23	28.7	3.81	2.20
	80	26.2	3.07	2.49	26.7	3.19	2.44	27.2	3.31	2.40
40	60	25.5	3.69	2.02	26.1	3.82	2.00	26.7	3.95	1.97
	70	24.3	3.15	2.25	24.8	3.27	2.21	25.3	3.39	2.18
	80	23.0	2.71	2.48	23.5	2.82	2.43	23.9	2.93	2.38
30	60	21.2	3.17	1.95	21.4	3.22	1.94	21.6	3.26	1.93
	70	20.3	2.74	2.16	20.5	2.78	2.14	20.7	2.83	2.13
	80	19.3	2.38	2.37	19.5	2.42	2.35	19.7	2.47	2.32
17	60	16.3	2.55	1.86	16.1	2.51	1.87	15.9	2.47	1.88
	70	14.3	2.00	2.10	14.5	2.03	2.08	14.5	2.06	2.06
	80	12.4	1.55	2.33	12.8	1.63	2.29	13.2	1.71	2.24
10	60	13.7	2.20	1.81	13.6	2.16	1.84	13.6	2.13	1.86
	70	12.7	1.84	2.01	12.5	1.81	2.03	12.4	1.77	2.04
	80	11.7	1.54	2.21	11.4	1.51	2.21	11.2	1.47	2.22

HEATING PERFORMANCE DATA - 3 TON										
PACKAGED UNIT MODEL NO.		PHE4B3621								
AIR TEMP. ENTERING OUTDOOR COIL	AIR TEMP. ENTERING INDOOR COIL	ID CFM								
		1000			1200			1400		
		MBH	COP	KW	MBH	COP	KW	MBH	COP	KW
60	60	41.6	4.67	2.60	42.7	4.87	2.56	43.8	5.08	2.52
	70	39.9	4.08	2.86	40.9	4.25	2.81	41.9	4.42	2.77
	80	38.2	3.58	3.11	39.1	3.73	3.06	40.0	3.88	3.01
47	60	35.3	4.14	2.49	35.8	4.23	2.47	36.3	4.33	2.45
	70	33.8	3.59	2.75	34.2	3.67	2.72	34.7	3.76	2.69
	80	32.3	3.13	3.01	32.7	3.21	2.97	33.0	3.29	2.93
40	60	31.5	3.76	2.45	32.0	3.83	2.44	32.4	3.90	2.42
	70	30.1	3.26	2.70	30.5	3.33	2.68	31.0	3.40	2.66
	80	28.7	2.84	2.95	29.1	2.91	2.92	29.5	2.97	2.90
30	60	26.8	3.29	2.38	27.0	3.31	2.38	27.2	3.33	2.39
	70	25.3	2.82	2.62	25.6	2.85	2.62	25.8	2.88	2.62
	80	23.9	2.43	2.87	24.1	2.47	2.86	24.4	2.50	2.84
17	60	20.1	2.54	2.31	20.3	2.54	2.33	20.4	2.54	2.35
	70	18.7	2.16	2.52	18.4	2.11	2.54	18.0	2.06	2.56
	80	17.3	1.84	2.74	16.5	1.75	2.76	15.7	1.65	2.77
10	60	17.6	2.28	2.25	17.6	2.26	2.28	17.7	2.23	2.31
	70	16.1	1.90	2.48	16.3	1.89	2.50	16.4	1.89	2.52
	80	14.7	1.59	2.70	14.9	1.59	2.72	15.0	1.60	2.74

HEATING PERFORMANCE DATA - 3.5 TON										
PACKAGED UNIT MODEL NO.		PHE4B4221								
AIR TEMP. ENTERING OUTDOOR COIL	AIR TEMP. ENTERING INDOOR COIL	ID CFM								
		1200			1400			1600		
		MBH	COP	KW	MBH	COP	KW	MBH	COP	KW
60	60	48.1	4.38	3.21	49.1	4.36	3.29	50.1	4.33	3.38
	70	46.0	3.84	3.50	46.9	3.83	3.58	47.8	3.82	3.65
	80	43.9	3.38	3.79	44.7	3.38	3.86	45.4	3.38	3.92
47	60	40.1	3.83	3.06	40.7	3.75	3.16	41.2	3.68	3.27
	70	38.0	3.32	3.34	38.5	3.27	3.44	39.0	3.22	3.54
	80	35.9	2.89	3.63	36.3	2.86	3.71	36.8	2.83	3.80
40	60	35.3	3.41	3.02	35.7	3.31	3.15	36.1	3.22	3.27
	70	33.2	2.90	3.35	33.4	2.82	3.46	33.6	2.75	3.57
	80	31.1	2.47	3.67	31.1	2.41	3.77	31.1	2.35	3.87
30	60	25.5	2.52	2.95	27.9	2.65	3.08	30.3	2.76	3.20
	70	25.8	2.32	3.24	26.4	2.30	3.36	27.0	2.27	3.47
	80	26.1	2.16	3.53	25.0	2.00	3.64	23.8	1.86	3.74
17	60	21.6	2.19	2.87	22.0	2.13	3.02	22.5	2.08	3.16
	70	20.0	1.86	3.14	19.8	1.76	3.28	19.6	1.68	3.41
	80	18.4	1.57	3.41	17.5	1.45	3.53	16.7	1.33	3.65
10	60	17.6	1.80	2.85	17.0	1.65	3.01	16.4	1.51	3.16
	70	16.7	1.58	3.09	16.0	1.44	3.24	15.3	1.31	3.38
	80	15.8	1.39	3.32	14.9	1.26	3.46	14.1	1.14	3.60

HEATING PERFORMANCE DATA - 4 TON										
PACKAGED UNIT MODEL NO.		PHE4B4821								
AIR TEMP. ENTERING OUTDOOR COIL	AIR TEMP. ENTERING INDOOR COIL	ID CFM								
		1400			1600			1800		
		MBH	COP	KW	MBH	COP	KW	MBH	COP	KW
60	60	56.5	4.87	3.39	57.8	4.95	3.41	59.0	5.03	3.43
	70	54.9	4.29	3.74	56.0	4.37	3.74	57.0	4.46	3.74
	80	53.3	3.80	4.09	54.2	3.89	4.07	55.1	3.98	4.05
47	60	48.4	4.33	3.27	49.2	4.37	3.29	49.9	4.42	3.30
	70	46.7	3.77	3.62	47.4	3.82	3.62	48.1	3.87	3.63
	80	45.0	3.32	3.97	45.6	3.36	3.96	46.2	3.41	3.95
40	60	43.3	3.94	3.21	43.8	3.96	3.23	44.3	3.98	3.25
	70	40.5	3.36	3.52	41.7	3.44	3.55	42.9	3.51	3.57
	80	37.8	2.88	3.84	39.7	3.00	3.86	41.5	3.12	3.89
30	60	37.5	3.50	3.13	37.0	3.40	3.18	36.6	3.31	3.23
	70	35.2	2.93	3.51	34.7	2.88	3.52	34.2	2.83	3.53
	80	32.9	2.47	3.88	32.3	2.45	3.86	31.8	2.42	3.84
17	60	28.4	2.71	3.06	28.2	2.66	3.09	28.0	2.61	3.13
	70	27.2	2.33	3.41	27.0	2.30	3.43	26.9	2.27	3.46
	80	26.0	2.02	3.76	25.9	2.00	3.77	25.8	1.99	3.79
10	60	25.8	2.53	2.98	25.5	2.43	3.05	25.1	2.34	3.12
	70	24.1	2.13	3.30	24.0	2.09	3.36	24.0	2.05	3.41
	80	22.4	1.80	3.62	22.6	1.80	3.66	22.9	1.81	3.70

HEATING PERFORMANCE DATA - 5 TON										
PACKAGED UNIT MODEL NO.		PHE4B6021								
AIR TEMP. ENTERING OUTDOOR COIL	AIR TEMP. ENTERING INDOOR COIL	ID CFM								
		1600			1800			2000		
		MBH	COP	KW	MBH	COP	KW	MBH	COP	KW
60	60	70.2	4.50	4.55	71.2	4.54	4.59	72.2	4.57	4.61
	70	67.6	3.94	5.01	68.4	3.98	5.03	69.1	4.02	5.03
	80	65.0	3.48	5.46	65.5	3.51	5.46	66.1	3.56	5.44
47	60	58.4	3.98	4.28	58.7	3.93	4.36	59.0	3.88	4.44
	70	56.3	3.46	4.76	56.5	3.44	4.80	56.8	3.42	4.86
	80	54.1	3.03	5.23	54.3	3.03	5.25	54.6	3.03	5.26
40	60	52.5	3.69	4.17	52.8	3.61	4.28	53.0	3.54	4.38
	70	49.8	3.15	4.63	50.4	3.13	4.71	51.1	3.13	4.78
	80	47.0	2.70	5.09	48.1	2.73	5.13	49.1	2.77	5.17
30	60	38.2	2.87	3.89	38.2	2.77	4.03	38.2	2.68	4.15
	70	39.5	2.63	4.38	37.9	2.49	4.46	36.3	2.35	4.51
	80	40.9	2.45	4.88	37.7	2.25	4.88	34.4	2.06	4.88
17	60	29.5	2.33	3.71	32.5	2.41	3.94	35.4	2.48	4.17
	70	27.6	1.92	4.19	30.5	2.04	4.36	33.4	2.16	4.53
	80	25.6	1.59	4.69	28.5	1.74	4.78	31.5	1.88	4.88
10	60	30.1	2.31	3.79	29.9	2.21	3.96	29.8	2.12	4.11
	70	28.4	1.98	4.19	28.2	1.90	4.32	28.0	1.83	4.46
	80	26.8	1.71	4.57	26.5	1.65	4.69	26.2	1.59	4.82

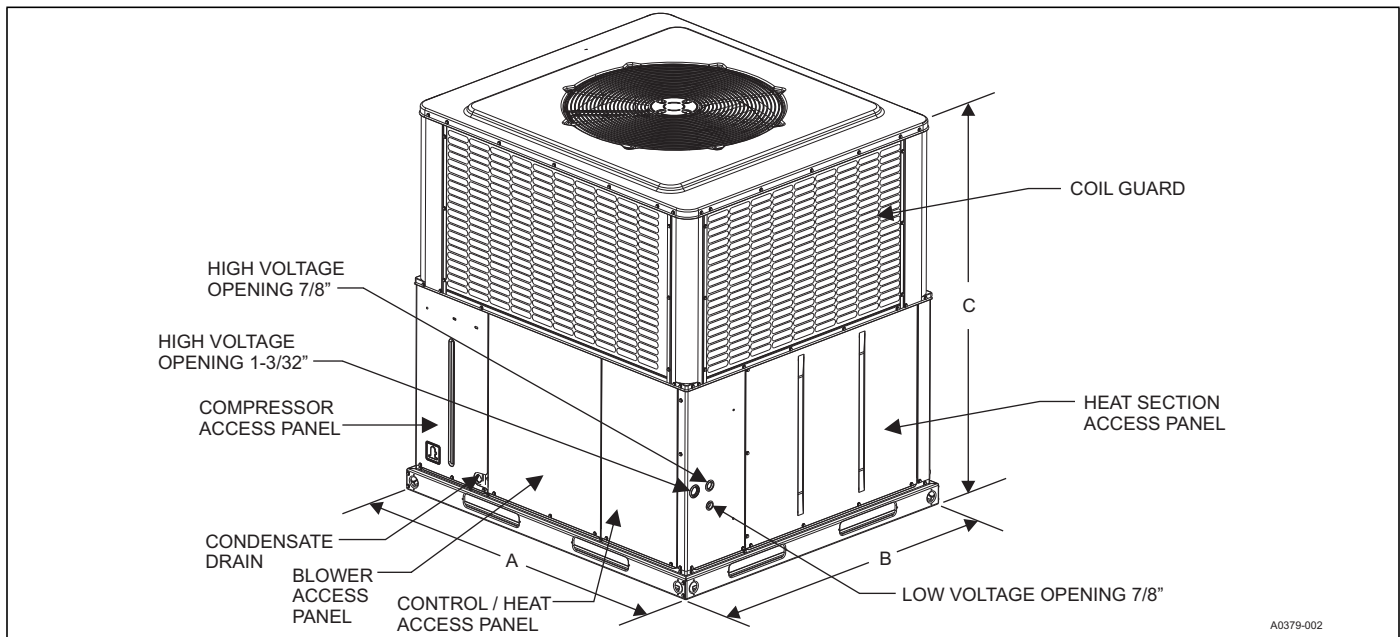

UNIT DIMENSIONS

Model	Dimensions (in.)		
	A	B	C
PHE4A2421	51-1/4	35-3/4	47
PHE4A3021	51-1/4	35-3/4	49
PHE4B3621	51-1/4	45-3/4	49
PHE4B4221	51-1/4	45-3/4	49
PHE4B4821	51-1/4	45-3/4	53
PHE4B6021	51-1/4	45-3/4	55

UNIT CLEARANCES

Direction	Distance (in.)	Direction	Distance (in.)
Top ¹	36	Right Side	36
Side Opposite Ducts	36	Left Side	24
Duct Panel	0	Bottom ^{2, 3}	1

1. There must be a minimum clearance of 1 in. on all sides of the supply air duct for the first 3 ft of the duct for 20 kW and 25 kW heaters (0 in. thereafter). For all other heaters, there must be a 0 in. clearance on all sides for the entire length of the supply air duct.
 2. Units must be installed outdoors. Overhanging structures or shrubs must not obstruct the outdoor air discharge outlet.
 3. Units can be installed on combustible materials made from wood or class A, B, or C roof covering materials if factory base rails are left in place as shipped.
- Note:** For units with a roof curb, the minimum clearance between combustible roof curb material and the supply air duct can be reduced from 1 in. to 1/2 in.

ELECTRIC HEAT MINIMUM SUPPLY AIR

Model	Voltage	Minimum Blower Speed for Electric Heat								
		Heater kW								
		2	5	8	10	13	15	18	20	25
PHE4A2421	208/230-1-60	Low (1)	Low (1)	Medium Low (2)	Medium (3)	Medium High (4)	--	--	--	--
PHE4A3021	208/230-1-60	Low (1)	Low (1)	Low (1)	Medium Low (2)	Medium (3)	High (5)	--	--	--
PHE4B3621	208/230-1-60	Low (1)	Low (1)	Low (1)	Low (1)	Medium Low (2)	High (5)	--	--	--
PHE4B4221	208/230-1-60	--	Low (1)	Low (1)	Low (1)	Low (1)	Medium Low (2)	Medium High (4)	High (5)	--
PHE4B4821	208/230-1-60	--	Low (1)	Low (1)	Low (1)	Low (1)	Low (1)	Medium Low (2)	Medium High (4)	--
PHE4B6021	208/230-1-60	--	Low (1)	Low (1)	Low (1)	Low (1)	Low (1)	Low (1)	Medium Low (2)	Medium High (4)

INDOOR BLOWER SPECIFICATIONS

Model	Motor				
	HP	RPM	EFF.	SF	Frame
PHE4A2421	1/2	Variable	0.8	1.0	48
PHE4A3021	1/2	Variable	0.8	1.0	48
PHE4B3621	1/2	Variable	0.8	1.0	48
PHE4B4221	3/4	Variable	0.8	1.0	48
PHE4B4821	3/4	Variable	0.8	1.0	48
PHE4B6021	1	Variable	0.8	1.0	48

COOLING SOUND PERFORMANCE

Model (Tons)	Sound Rating ¹ dB(A)	Octave Band Centerline Frequency (Hz)						
		125	250	500	1000	2000	4000	8000
PHE4A2421	72.4	61.8	60.5	63.1	62.5	57.1	51.8	44.0
PHE4A3021	68.7	58.3	58.8	56.6	57.3	54.0	48.4	43.0
PHE4B3621	73.2	61.8	63.2	60.5	64.4	58.9	53.4	45.9
PHE4B4221	73.6	62.4	59.0	61.5	64.9	60.3	55.8	50.6
PHE4B4821	74.0	62.0	62.0	60.9	64.7	60.1	56.6	49.2
PHE4B6021	74.1	65.9	61.8	60.8	63.5	58.7	55.5	48.3

1. Rated in accordance with AHRI Standard 270.

HEATING SOUND PERFORMANCE

Model (Tons)	Sound Rating ¹ dB(A)	Octave Band Centerline Frequency (Hz)						
		125	250	500	1000	2000	4000	8000
PHE4A2421	70.3	64.7	59.2	59.8	58.1	54.3	49.2	43.2
PHE4A3021	69.0	57.5	58.0	58.0	63.8	53.2	47.6	49.7
PHE4B3621	72.8	60.1	62.5	60.4	64.5	58.8	53.0	46.0
PHE4B4221	73.6	62.4	58.3	61.5	65.7	59.7	54.4	47.9
PHE4B4821	74.6	66.0	63.3	61.1	64.6	60.2	56.4	48.9
PHE4B6021	73.7	61.6	59.4	60.5	63.6	58.7	55.1	51.4

1. Rated in accordance with AHRI Standard 270.

ELECTRICAL DATA FOR 208/230-1-60 SINGLE SOURCE POWER

Model	Compressor			OD Fan Motor FLA	Blower Motor FLA	Electric Heat Option					MCA ¹		Max Fuse ² or Breaker Size ³		
	RLA	LRA	MCC			Heater Kit ⁴	Heater kW		Stages	Heater Amps		Amps		208	230
				208	230		208	230		208	230				
PHE4A24	10	62	16	0.7	3.8	none	--	--	--	--	--	18.1	18.1	25	25
						6HK16500206	1.8	2.2	1	8.7	9.6	28.2	29.3	35	35
						6HK16500506	3.6	4.4	1	17.3	19.1	39.0	41.3	40	45
						6HK16500806	5.8	7.1	1	27.9	30.9	52.2	56.0	60	60
						6HK16501006	7.2	8.8	1	34.6	38.3	60.6	65.2	70	70
						6HK16501306	9.4	11.5	2	45.2	50.0	73.9	79.9	80	80
PHE4A30	14	73	22	0.6	3.8	none	--	--	--	--	--	22.0	22.0	35	35
						6HK16500206	1.8	2.2	1	8.7	9.6	32.8	34.0	40	45
						6HK16500506	3.6	4.4	1	17.3	19.1	43.7	45.9	50	50
						6HK16500806	5.8	7.1	1	27.9	30.9	56.9	60.6	60	70
						6HK16501006	7.2	8.8	1	34.6	38.3	65.3	69.9	70	70
						6HK16501306	9.4	11.5	2	45.2	50.0	78.5	84.5	80	90
						6HK16501506	10.8	13.2	2	51.9	57.4	86.9	93.8	90	100
PHE4B36	17	79	26	1.7	3.8	none	--	--	--	--	--	26.4	26.4	40	40
						6HK16500206	1.8	2.2	1	8.7	9.6	37.2	38.3	50	50
						6HK16500506	3.6	4.4	1	17.3	19.1	48.0	50.3	60	60
						6HK16500806	5.8	7.1	1	27.9	30.9	61.2	65.0	70	70
						6HK16501006	7.2	8.8	1	34.6	38.3	69.6	74.2	70	80
						6HK16501306	9.4	11.5	2	45.2	50.0	82.9	88.9	90	90
						6HK16501506	10.8	13.2	2	51.9	57.4	91.3	98.1	100	100
PHE4B42	17.90	112	28	1.7	5.4	none	--	--	--	--	--	29.5	29.5	45	45
						6HK16500506	3.6	4.4	1	17.3	19.1	51.1	53.4	60	60
						6HK16500806	5.8	7.1	1	27.9	30.9	64.3	68.1	70	70
						6HK16501006	7.2	8.8	1	34.6	38.3	72.7	77.3	80	80
						6HK16501306	9.4	11.5	2	45.2	50.0	86.0	92.0	90	100
						6HK16501506	10.8	13.2	2	51.9	57.4	94.4	101.2	100	110
						6HK16501806	13.0	15.9	2	62.5	69.1	107.6	115.9	110	125
						6HK16502006	14.4	17.6	2	69.2	76.5	116.0	125.1	125	150
PHE4B48	24.30	117	34	1.7	5.4	none	--	--	--	--	--	34.4	34.4	50	50
						6HK16500506	3.6	4.4	1	17.3	19.1	56.0	58.3	70	70
						6HK16500806	5.8	7.1	1	27.9	30.9	69.2	72.9	80	80
						6HK16501006	7.2	8.8	1	34.6	38.3	77.6	82.2	90	90
						6HK16501306	9.4	11.5	2	45.2	50.0	90.8	96.9	100	100
						6HK16501506	10.8	13.2	2	51.9	57.4	99.3	106.1	100	110
						6HK16501806	13.0	15.9	2	62.5	69.1	112.5	120.8	125	125
						6HK16502006	14.4	17.6	2	69.2	76.5	120.9	130.0	125	150
PHE4B60	24.40	144	38	1.7	7	none	--	--	--	--	--	39.2	39.2	60	60
						6HK16500506	3.6	4.4	1	17.3	19.1	60.8	63.1	80	80
						6HK16500806	5.8	7.1	1	27.9	30.9	74.1	77.8	90	90
						6HK16501006	7.2	8.8	1	34.6	38.3	82.5	87.0	90	100
						6HK16501306	9.4	11.5	2	45.2	50.0	95.7	101.7	100	110
						6HK16501506	10.8	13.2	2	51.9	57.4	104.1	110.9	110	125
						6HK16501806	13.0	15.9	2	62.5	69.1	117.3	125.6	125	150
						6HK16502006	14.4	17.6	2	69.2	76.5	125.7	134.9	150	150

1. MCA = Minimum Circuit Ampacity.

2. Maximum Overcurrent Protection per standard UL 1995.

3. Fuse or HACR circuit breaker is field installed.

4. Single Point Connection Kit required.

ELECTRICAL DATA FOR 208-1-60 MULTI SOURCE POWER

Model	Compressor			OD Fan Motor	Blower Motor	Electric Heat Option				Multi Source									
	RLA	LRA	MCC	FLA	FLA	Heater Kit	Heater kW	Stages	Heater Amps										
							208		208	208	208	208	208	208	208	208	208		
Multi Source: Compressor Circuit and Heat Circuits						Multi Source:	Circuit 1 Compressor Circuit												
							Circuit 2 Heat			MCA¹	MOP²	MCA¹	MOP²	MCA¹	MOP²	MCA¹	MOP²	MCA¹	MOP²
							Circuit 3 Heat			Amps		Amps		Amps		Amps		Amps	
							Circuit 4 Heat			Circuit 1		Circuit 2		Circuit 3		Circuit 4			
PHE4A24	10.30	45	14	0.7	3.8	none	--	--	--	18.1	25	--	--	--	--	--	--		
						6HK(0,1)6500206	1.8	1	8.7	18.1	25	10.8	15	--	--	--	--		
						6HK(0,1)6500506	3.6	1	17.3	18.1	25	21.6	25	--	--	--	--		
						6HK(0,1)6500806	5.8	1	27.9	18.1	25	34.9	40	--	--	--	--		
						6HK(0,1)6501006	7.2	1	34.6	18.1	25	43.3	45	--	--	--	--		
						6HK16501306	9.4	2	45.2	18.1	25	37.2	40	18.8	20	--	--		
						6HK26501306	9.4	2	45.2	18.1	25	56.5	60	--	--	--	--		
PHE4A30	14.10	57	15	0.6	3.8	none	--	--	--	22.0	35	--	--	--	--	--	--		
						6HK(0,1)6500206	1.8	1	8.7	22.0	35	10.8	15	--	--	--	--		
						6HK(0,1)6500506	3.6	1	17.3	22.0	35	21.6	25	--	--	--	--		
						6HK(0,1)6500806	5.8	1	27.9	22.0	35	34.9	40	--	--	--	--		
						6HK(0,1)6501006	7.2	1	34.6	22.0	35	43.3	45	--	--	--	--		
						6HK16501306	9.4	2	45.2	22.0	35	37.7	40	18.8	20	--	--		
						6HK26501306	10.8	2	51.9	22.0	35	43.3	50	21.6	25	--	--		
PHE4B36	16.70	78	23	1.7	3.8	none	--	--	--	26.4	40	--	--	--	--	--	--		
						6HK(0,1)6500206	1.8	1	8.7	26.4	40	10.8	15	--	--	--	--		
						6HK(0,1)6500506	3.6	1	17.3	26.4	40	21.6	25	--	--	--	--		
						6HK(0,1)6500806	5.8	1	27.9	26.4	40	34.9	40	--	--	--	--		
						6HK(0,1)6501006	7.2	1	34.6	26.4	40	43.3	45	--	--	--	--		
						6HK16501306	9.4	2	45.2	26.4	40	37.7	40	18.8	20	--	--		
						6HK16501506	10.8	2	51.9	26.4	40	43.3	50	21.6	25	--	--		
PHE4B42	17.90	112	28	1.7	5.4	none	--	--	--	29.5	45	--	--	--	--	--	--		
						6HK(0,1)6500506	3.6	1	17.3	29.5	45	21.6	25	--	--	--	--		
						6HK(0,1)6500806	5.8	1	27.9	29.5	45	34.9	40	--	--	--	--		
						6HK(0,1)6501006	7.2	1	34.6	29.5	45	43.3	45	--	--	--	--		
						6HK16501306	9.4	2	45.2	29.5	45	37.7	40	18.8	20	--	--		
						6HK16501506	10.8	2	51.9	29.5	45	43.3	50	21.6	25	--	--		
						6HK16501806	13.0	2	62.5	29.5	45	39.1	40	39.1	40	--	--		
						6HK16502006	14.4	2	69.2	29.5	45	43.3	45	43.3	45	--	--		
						6HK26501306	9.4	2	45.2	29.5	45	56.5	60	--	--	--	--		
						6HK26501506	10.8	2	51.9	29.5	45	64.9	70	--	--	--	--		
PHE4B48	21.80	117	34	1.7	5.4	none	--	--	--	34.4	50	--	--	--	--	--	--		
						6HK(0,1)6500506	3.6	1	17.3	34.4	50	21.6	25	--	--	--	--		
						6HK(0,1)6500806	5.8	1	27.9	34.4	50	34.9	40	--	--	--	--		
						6HK(0,1)6501006	7.2	1	34.6	34.4	50	43.3	45	--	--	--	--		
						6HK16501306	9.4	2	45.2	34.4	50	37.7	40	18.8	20	--	--		
						6HK16501506	10.8	2	51.9	34.4	50	43.3	50	21.6	25	--	--		
						6HK16501806	13.0	2	62.5	34.4	50	39.1	40	39.1	40	--	--		
						6HK16502006	14.4	2	69.2	34.4	50	43.3	45	43.3	45	--	--		
						6HK26501306	9.4	2	45.2	34.4	50	56.5	60	--	--	--	--		
						6HK26501506	10.8	2	51.9	34.4	50	64.9	70	--	--	--	--		

For notes, see end of table on next page.

ELECTRICAL DATA FOR 208-1-60 MULTI SOURCE POWER (Continued)

Model	Compressor			OD Fan Motor	Blower Motor	Electric Heat Option				Multi Source										
	RLA	LRA	MCC	FLA	FLA	Heater Kit	Heater kW	Stages	Heater Amps											
							208		208	208	208	208	208	208	208	208	208			
Multi Source: Compressor Circuit and Heat Circuits						Multi Source:	Circuit 1 Compressor Circuit													
							Circuit 2 Heat				MCA ¹	MOP ²	MCA ¹	MOP ²	MCA ¹	MOP ²	MCA ¹	MOP ²	MCA ¹	MOP ²
							Circuit 3 Heat				Amps		Amps		Amps		Amps		Amps	
							Circuit 4 Heat				Circuit 1		Circuit 2		Circuit 3		Circuit 4			
PHE4B60	24.00	144	38	1.7	7.0	none	--	--	--	39.2	60	--	--	--	--	--	--			
						6HK(0,1)6500506	3.6	1	17.3	39.2	60	21.6	25	--	--	--	--			
						6HK(0,1)6500806	5.8	1	27.9	39.2	60	34.9	40	--	--	--	--			
						6HK(0,1)6501006	7.2	1	34.6	39.2	60	43.3	45	--	--	--	--			
						6HK16501306	9.4	2	45.2	39.2	60	37.2	40	18.8	20	--	--			
						6HK16501506	10.8	2	51.9	39.2	60	43.3	50	21.6	25	--	--			
						6HK16501806	13.0	2	62.5	39.2	60	39.1	40	39.1	40	--	--			
						6HK16502006	14.4	2	69.2	39.2	60	43.3	45	43.3	45	--	--			
						6HK26501306	9.4	2	45.2	39.2	60	56.5	60	--	--	--	--			
						6HK26501506	10.8	2	51.9	39.2	60	64.9	70	--	--	--	--			
						6HK26501806	13.0	2	62.5	39.2	60	78.1	80	--	--	--	--			
						6HK26502006	14.4	2	69.2	39.2	60	86.5	90	--	--	--	--			
						6HK16502506	18.0	2	86.5	39.2	60	43.3	45	43.3	45	21.6	25			
6HK26502506	18.0	2	86.5	39.2	60	108.2	110	--	--	--	--									

1. MCA = Minimum Circuit Ampacity.
 2. MOP = Maximum Overcurrent Protection device. Must be HACR type circuit breaker or time delay fuse.

ELECTRICAL DATA FOR 230-1-60 MULTI SOURCE POWER

Model	Compressor			OD Fan Motor	Blower Motor	Electric Heat Option				Multi Source										
	RLA	LRA	MCC	FLA	FLA	Heater Kit	Heater kW	Stages	Heater Amps											
							230		230	230	230	230	230	230	230	230				
Multi Source: Compressor Circuit and Heat Circuits						Multi Source:	Circuit 1 Compressor Circuit													
							Circuit 2 Heat				MCA ¹	MOP ²	MCA ¹	MOP ²	MCA ¹	MOP ²	MCA ¹	MOP ²	MCA ¹	MOP ²
							Circuit 3 Heat				Amps		Amps		Amps		Amps		Amps	
							Circuit 4 Heat				Circuit 1		Circuit 2		Circuit 3		Circuit 4			
PHE4A24	10.30	45	14	0.7	3.8	none	--	--	--	18.1	25	--	--	--	--	--				
						6HK(0,1)6500206	2.2	1	9.6	18.1	25	12.0	15	--	--	--	--			
						6HK(0,1)6500506	4.4	1	19.1	18.1	25	23.9	25	--	--	--	--			
						6HK(0,1)6500806	7.1	1	30.9	18.1	25	38.6	40	--	--	--	--			
						6HK(0,1)6501006	8.8	1	38.3	18.1	25	47.8	50	--	--	--	--			
						6HK16501306	11.5	2	50.0	18.1	25	41.7	45	20.8	25	--	--			
						6HK26501306	11.5	2	50.0	18.1	25	62.5	70	--	--	--	--			
PHE4A30	14.10	57	15	0.6	3.8	none	--	--	--	22.0	35	--	--	--	--	--				
						6HK(0,1)6500206	2.2	1	9.6	22.0	35	12.0	15	--	--	--	--			
						6HK(0,1)6500506	4.4	1	19.1	22.0	35	23.9	25	--	--	--	--			
						6HK(0,1)6500806	7.1	1	30.9	22.0	35	38.6	40	--	--	--	--			
						6HK(0,1)6501006	8.8	1	38.3	22.0	35	47.8	50	--	--	--	--			
						6HK16501306	11.5	2	50.0	22.0	35	41.7	45	20.8	25	--	--			
						6HK16501506	13.2	2	57.4	22.0	35	47.8	50	23.9	25	--	--			
						6HK26501306	11.5	2	50.0	22.0	35	62.5	70	--	--	--	--			
6HK26501506	13.2	2	57.4	22.0	35	71.7	80	--	--	--	--									
PHE4B36	16.70	78	23	1.7	3.8	none	--	--	--	26.4	40	--	--	--	--	--				
						6HK(0,1)6500206	2.2	1	9.6	26.4	40	12.0	15	--	--	--	--			
						6HK(0,1)6500506	4.4	1	19.1	26.4	40	23.9	25	--	--	--	--			
						6HK(0,1)6500806	7.1	1	30.9	26.4	40	38.6	40	--	--	--	--			
						6HK(0,1)6501006	8.8	1	38.3	26.4	40	47.8	50	--	--	--	--			
						6HK16501306	11.5	2	50.0	26.4	40	41.7	45	20.8	25	--	--			
						6HK16501506	13.2	2	57.4	26.4	40	47.8	50	23.9	25	--	--			
						6HK26501306	11.5	2	50.0	26.4	40	62.5	70	--	--	--	--			
6HK26501506	13.2	2	57.4	26.4	40	71.7	80	--	--	--	--									

For notes, see end of table on next page.

ELECTRICAL DATA FOR 230-1-60 MULTI SOURCE POWER (Continued)

Model	Compressor			OD Fan Motor	Blower Motor	Electric Heat Option			Multi Source													
	RLA	LRA	MCC	FLA	FLA	Heater Kit	Heater kW	Stages	Heater Amps	230	230	230	230	230	230	230						
							230		230													
Multi Source: Compressor Circuit and Heat Circuits						Multi Source:	Circuit 1 Compressor Circuit								MCA ¹ Amps	MOP ²	MCA ¹ Amps	MOP ²	MCA ¹ Amps	MOP ²	MCA ¹ Amps	MOP ²
							Circuit 2 Heat															
							Circuit 3 Heat															
							Circuit 4 Heat															
PHE4B42	17.90	112	28	1.7	5.4	none	--	--	--	29.5	45	--	--	--	--	--	--					
						6HK(0,1)6500506	4.4	1	19.1	29.5	45	23.9	25	--	--	--	--					
						6HK(0,1)6500806	7.1	1	30.9	29.5	45	38.6	40	--	--	--	--					
						6HK(0,1)6501006	8.8	1	38.3	29.5	45	47.8	50	--	--	--	--					
						6HK16501306	11.5	2	50.0	29.5	45	41.7	45	20.8	25	--	--					
						6HK16501506	13.2	2	57.4	29.5	45	47.8	50	23.9	25	--	--					
						6HK16501806	15.9	2	69.1	29.5	45	43.2	45	43.2	45	--	--					
						6HK16502006	17.6	2	76.5	29.5	45	47.8	50	47.8	50	--	--					
						6HK26501306	11.5	2	50.0	29.5	45	62.5	70	--	--	--	--					
						6HK26501506	13.2	2	57.4	29.5	45	71.7	80	--	--	--	--					
						6HK26501806	15.9	2	69.1	29.5	45	86.4	90	--	--	--	--					
6HK26502006	17.6	2	76.5	29.5	45	95.7	100	--	--	--	--											
PHE4B48	21.80	117	34	1.7	5.4	none	--	--	--	34.4	50	--	--	--	--	--	--					
						6HK(0,1)6500506	4.4	1	19.1	34.4	50	23.9	25	--	--	--	--					
						6HK(0,1)6500806	7.1	1	30.9	34.4	50	38.6	40	--	--	--	--					
						6HK(0,1)6501006	8.8	1	38.3	34.4	50	47.8	50	--	--	--	--					
						6HK16501306	11.5	2	50.0	34.4	50	41.7	45	20.8	25	--	--					
						6HK16501506	13.2	2	57.4	34.4	50	47.8	50	23.9	25	--	--					
						6HK16501806	15.9	2	69.1	34.4	50	43.2	45	43.2	45	--	--					
						6HK16502006	17.6	2	76.5	34.4	50	47.8	50	47.8	50	--	--					
						6HK26501306	11.5	2	50.0	34.4	50	62.5	70	--	--	--	--					
						6HK26501506	13.2	2	57.4	34.4	50	71.7	80	--	--	--	--					
						6HK26501806	15.9	2	69.1	34.4	50	86.4	90	--	--	--	--					
6HK26502006	17.6	2	76.5	34.4	50	95.7	100	--	--	--	--											
PHE4B60	24.00	144	38	1.7	7.0	none	--	--	--	39.2	60	--	--	--	--	--	--					
						6HK(0,1)6500506	4.4	1	19.1	39.2	60	23.9	25	--	--	--	--					
						6HK(0,1)6500806	7.1	1	30.9	39.2	60	38.6	40	--	--	--	--					
						6HK(0,1)6501006	8.8	1	38.3	39.2	60	47.8	50	--	--	--	--					
						6HK16501306	11.5	2	50.0	39.2	60	41.7	45	20.8	25	--	--					
						6HK16501506	13.2	2	57.4	39.2	60	47.8	50	23.9	25	--	--					
						6HK16501806	15.9	2	69.1	39.2	60	43.2	45	43.2	45	--	--					
						6HK16502006	17.6	2	76.5	39.2	60	47.8	50	47.8	50	--	--					
						6HK26501306	11.5	2	50.0	39.2	60	62.5	70	--	--	--	--					
						6HK26501506	13.2	2	57.4	39.2	60	71.7	80	--	--	--	--					
						6HK26501806	15.9	2	69.1	39.2	60	86.4	90	--	--	--	--					
						6HK26502006	17.6	2	76.5	39.2	60	95.7	100	--	--	--	--					
						6HK16502506	22.0	2	95.7	39.2	60	47.8	50	47.8	50	23.9	25					
6HK26502506	22.0	2	95.7	39.2	60	119.6	125	--	--	--	--											

1. MCA = Minimum Circuit Ampacity.

2. MOP = Maximum Overcurrent Protection device. Must be HACR type circuit breaker or time delay fuse.

ELECTRIC HEAT PERFORMANCE DATA: 208/230-1-60

Heater Models ^{1,2}		Nominal kW @240 V	Total Heat				kW Staging			
			kW		MBH		W1 Only		W1 + W2	
			208 V	230 V	208 V	230 V	208 V	230 V	208 V	230 V
1PH	6HK(0,1)6500206	2.4	1.8	2.2	6.2	7.5	1.8	2.2	1.8	2.2
	6HK(0,1)6500506	4.8	3.6	4.4	12.3	15	3.6	4.4	3.6	4.4
	6HK(0,1)6500806	7.7	5.8	7.1	19.7	24.1	5.8	7.1	5.8	7.1
	6HK(0,1)6501006	9.6	7.2	8.8	24.6	30.1	7.2	8.8	7.2	8.8
	6HK(1,2)6501306	12.5	9.4	11.5	32	39.2	3.1	3.8	9.4	11.5
	6HK(1,2)6501506	14.4	10.8	13.2	36.9	45.1	3.6	4.4	10.8	13.2
	6HK(1,2)6501806	17.3	13	15.9	44.3	54.2	6.5	7.9	13	15.9
	6HK(1,2)6502006	19.2	14.4	17.6	49.2	60.2	7.2	8.8	14.4	17.6
	6HK(1,2)6502506	24.0	18	22	61.5	75.2	7.2	8.8	18	22

- (0,1) - 0 = no service disconnect OR 1 = with service disconnect.
- (1,2) - 1 = with service disconnect, no breaker jumper bar OR 2 = with service disconnect and breaker jumper bar.

SINGLE POINT WIRING KIT

Single Point Kit P/N	Unit Model Number	Breaker Size	Heat Kit
S1-2SPWK006	PHE4A24	25 A	Up to 13 kW
S1-2SPWK002	PHE4A30	35 A	Up to 15 kW
S1-2SPWK007	PHE4B36	40 A	Up to 15 kW
S1-2SPWK003	PHE4B42	45 A	Up to 20 kW
S1-2SPWK004	PHE4B48	50 A	Up to 20 kW
S1-2SPWK005	PHE4B60	60 A	Up to 20 kW

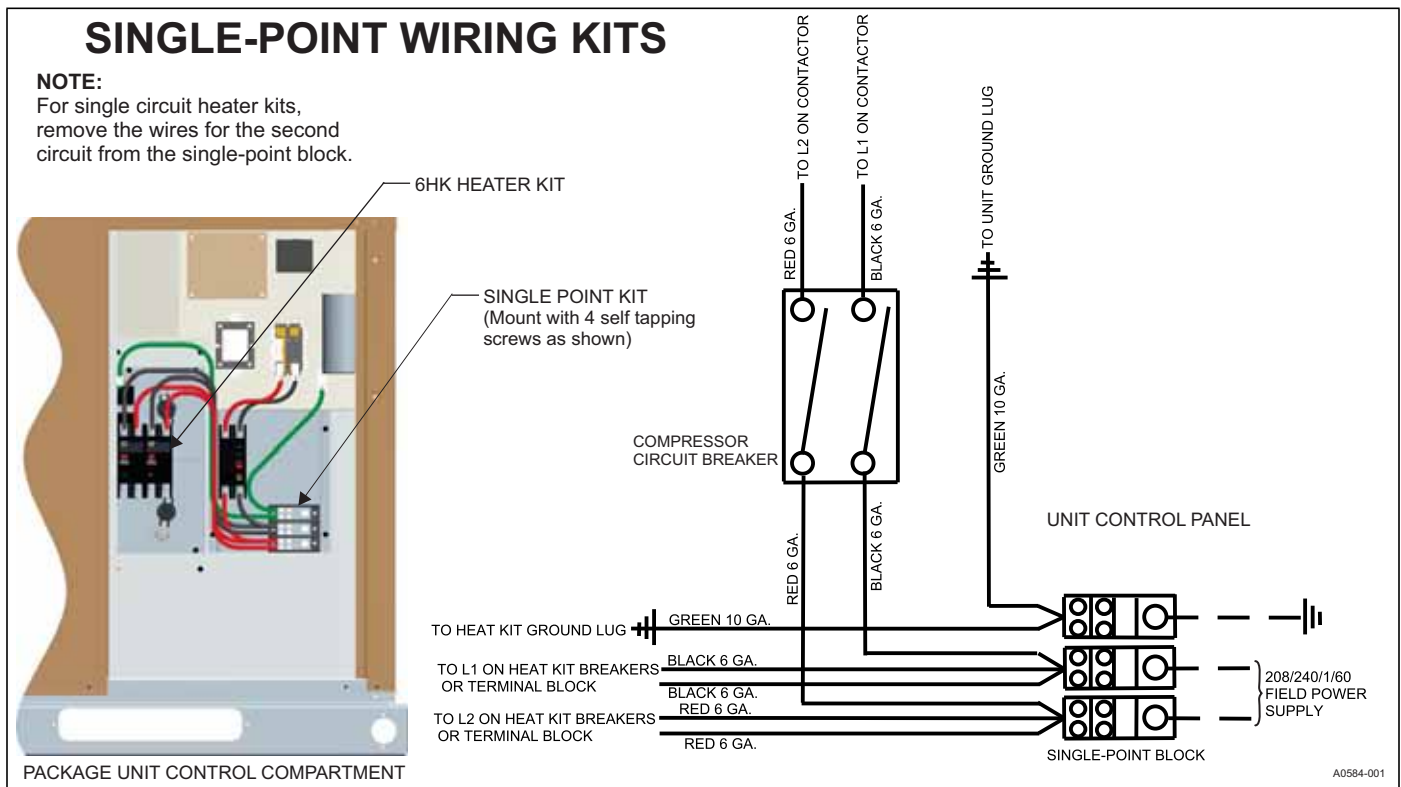

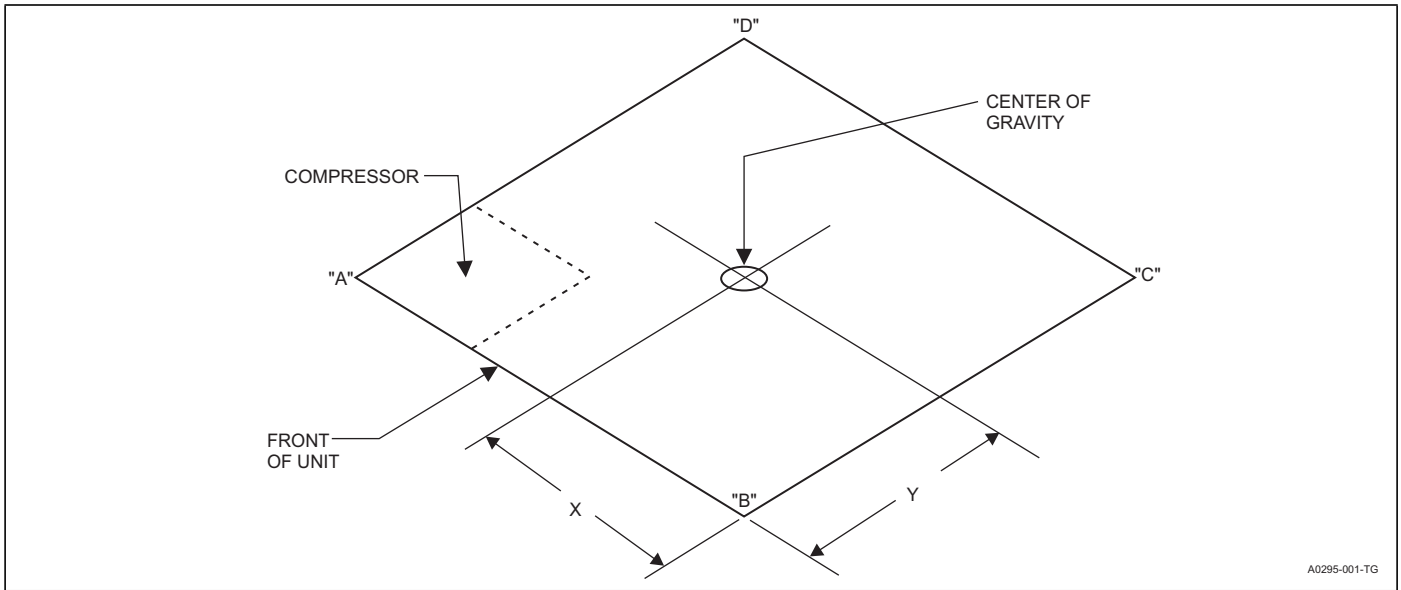

WEIGHTS AND DIMENSIONS

Model	Weight (lb)		Center of Gravity		4 Point Load Location (lb)			
	Shipping	Operating	X	Y	A	B	C	D
PHE4A2421	382	377	29	15	133	88	86	75
PHE4A3021	397	392	29	15	127	101	99	70
PHE4B3621	453	448	29	15	158	108	101	86
PHE4B4221	476	471	30	15	164	119	111	82
PHE4B4821	501	496	29	15	168	130	119	84
PHE4B6021	528	523	30	15	177	136	128	87

AIRFLOW PERFORMANCE - SIDE DUCT APPLICATION

Model	Motor Speed	External Static Pressure (in. W.C.)								
		0.1	0.2	0.3	0.4	0.5	0.6	0.7	0.8	1.0
		SCFM	SCFM	SCFM	SCFM	SCFM	SCFM	SCFM	SCFM	SCFM
PHE4A24	Low (1)	791	739	727	668	614	564	518	439	279
	Medium Low (2)	849	801	789	733	683	635	590	512	356
	Medium (3)	927	882	871	819	772	727	683	607	456
	Medium High (4)	999	958	948	899	855	812	769	696	549
	High (5)	1176	1143	1133	1092	1052	1014	976	908	771
PHE4A30	Low (1)	768	715	702	642	586	536	490	409	248
	Medium Low (2)	941	898	887	836	789	744	701	625	475
	Medium (3)	1026	987	977	930	886	844	802	729	584
	Medium High (4)	1112	1076	1067	1023	982	942	902	832	692
	High (5)	1176	1143	1133	1092	1052	1014	976	908	771
PHE4B36	Low (1)	1108	1050	984	921	857	791	726	660	528
	Medium Low (2)	1283	1225	1168	1115	1054	993	924	860	733
	Medium (3)	1362	1308	1252	1199	1142	1079	1015	979	905
	Medium High (4)	1403	1347	1290	1235	1177	1118	1058	995	869
	High (5)	1623	1569	1519	1470	1418	1362	1306	1246	1125
PHE4B42	Low (1)	1436	1382	1342	1304	1262	1220	1179	1131	1035
	Medium Low (2)	1544	1492	1455	1416	1376	1336	1294	1248	1156
	Medium (3)	1573	1523	1484	1445	1408	1367	1327	1279	1183
	Medium High (4)	1681	1640	1599	1557	1517	1478	1436	1393	1307
	High (5)	1935	1887	1834	1788	1743	1701	1651	1591	1471
PHE4B48	Low (1)	1620	1564	1517	1466	1418	1360	1308	1206	1002
	Medium Low (2)	1694	1630	1580	1530	1482	1430	1380	1292	1116
	Medium (3)	1798	1722	1669	1620	1572	1527	1480	1413	1280
	Medium High (4)	1835	1758	1703	1653	1604	1558	1511	1442	1304
	High (5)	2146	2085	2025	1960	1872	1862	1798	1735	1609
PHE4B60	Low (1)	1730	1682	1628	1592	1552	1517	1479	1439	1359
	Medium Low (2)	1858	1807	1749	1710	1667	1629	1589	1546	1460
	Medium (3)	2054	1998	1934	1890	1843	1801	1757	1710	1616
	Medium High (4)	2195	2144	2098	2049	2003	1955	1883	1868	1838
	High (5)	2445	2388	2306	2293	2235	2178	2129	2077	1973

Notes:

Airflow tested with dry coil conditions, without air filters, at 230 V.

Applications above 0.8 in. W.C. external static pressure are not recommended.

Brushless DC high efficiency standard ECM blower motor used for all indoor blower assemblies.

Minimal variations in airflow performance data result from operating at 208 V. Data above may be used in those cases.

Heating applications tested at 0.50 in. W.C. esp and cooling applications tested at 0.30 in. W.C. esp per standards.

AIRFLOW PERFORMANCE - BOTTOM DUCT APPLICATION

Model	Motor Speed	External Static Pressure (in. W.C.)								
		0.1	0.2	0.3	0.4	0.5	0.6	0.7	0.8	1.0
		SCFM	SCFM	SCFM	SCFM	SCFM	SCFM	SCFM	SCFM	SCFM
PHE4A24	Low (1)	791	755	745	686	632	585	537	455	290
	Medium Low (2)	851	813	801	743	692	648	603	524	367
	Medium (3)	938	905	890	836	788	745	702	623	465
	Medium High (4)	1069	978	969	921	872	830	787	713	565
	High (5)	1207	1182	1185	1122	1106	1066	1023	952	810
PHE4A30	Low (1)	768	730	720	659	604	555	508	424	258
	Medium Low (2)	943	911	900	847	800	759	716	641	490
	Medium (3)	1039	1013	998	949	905	865	825	748	596
	Medium High (4)	1190	1099	1090	1048	1002	963	923	853	713
	High (5)	1207	1182	1185	1122	1106	1066	1023	952	810
PHE4B36	Low (1)	1127	1082	1021	952	889	825	759	689	549
	Medium Low (2)	1306	1265	1205	1154	1094	1029	963	892	751
	Medium (3)	1354	1315	1259	1212	1153	1093	1024	990	920
	Medium High (4)	1397	1348	1297	1256	1195	1135	1077	1014	888
	High (5)	1634	1591	1548	1497	1446	1382	1309	1250	1131
PHE4B42	Low (1)	1455	1414	1379	1335	1294	1254	1212	1160	1056
	Medium Low (2)	1566	1532	1492	1455	1416	1372	1333	1280	1174
	Medium (3)	1565	1530	1491	1458	1419	1381	1336	1290	1198
	Medium High (4)	1675	1641	1606	1578	1535	1495	1455	1412	1326
	High (5)	1946	1909	1863	1815	1771	1721	1654	1595	1477
PHE4B48	Low (1)	1598	1548	1502	1454	1410	1362	1307	1251	1139
	Medium Low (2)	1663	1612	1568	1522	1476	1422	1370	1297	1152
	Medium (3)	1789	1733	1670	1650	1596	1578	1535	1483	1379
	Medium High (4)	1931	1814	1808	1736	1673	1650	1597	1519	1362
	High (5)	2131	2058	1998	1949	1892	1840	1788	1728	1608
PHE4B60	Low (1)	1655	1612	1596	1531	1461	1462	1429	1391	1316
	Medium Low (2)	1766	1720	1667	1629	1632	1539	1537	1498	1421
	Medium (3)	1987	1933	1861	1817	1820	1715	1725	1651	1504
	Medium High (4)	2114	2050	2047	1974	1899	1889	1920	1866	1758
	High (5)	2369	2308	2249	2183	2126	2088	2034	1990	1902

Notes:

Airflow tested with dry coil conditions, without air filters, at 230 V.

Applications above 0.8 in. W.C. external static pressure are not recommended.

Brushless DC high efficiency standard ECM blower motor used for all indoor blower assemblies.

Minimal variations in airflow performance data result from operating at 208 V. Data above may be used in those cases.

Heating applications tested at 0.50 in. W.C. esp and cooling applications tested at 0.30 in. W.C. esp per standards.

ADDITIONAL STATIC RESISTANCE

Size (Tons)	CFM	Wet Indoor Coil	Economizer ¹	Filter/Frame Kit
24 (2.0)	500	0.01	0.00	0.01
	600	0.01	0.00	0.02
	700	0.01	0.00	0.04
	800	0.02	0.01	0.06
	900	0.03	0.01	0.08
	1000	0.04	0.01	0.10
	1100	0.05	0.01	0.13
	1200	0.06	0.02	0.16
30 (2.5)	700	0.01	0.00	0.04
	800	0.02	0.01	0.06
	900	0.03	0.01	0.08
	1000	0.04	0.01	0.10
	1100	0.05	0.01	0.13
	1200	0.06	0.02	0.16
36 (3.0)	700	0.01	0.00	0.04
	800	0.02	0.01	0.06
	900	0.03	0.01	0.08
	1000	0.04	0.01	0.10
	1100	0.05	0.01	0.13
	1200	0.06	0.02	0.16
	1300	0.07	0.03	0.17
42 (3.5)	1100	0.02	0.02	0.04
	1200	0.03	0.02	0.04
	1300	0.04	0.02	0.05
	1400	0.05	0.03	0.05
	1500	0.06	0.04	0.06
	1600	0.07	0.04	0.07
	1700	0.07	0.04	0.08
48 (4.0)	1800	0.08	0.04	0.09
	1900	0.09	0.05	0.10
	2000	0.09	0.05	0.11
	1100	0.02	0.02	0.04
	1200	0.03	0.02	0.04
	1300	0.04	0.02	0.05
	1400	0.05	0.03	0.05
	1500	0.06	0.04	0.06
	1600	0.07	0.04	0.07
	1700	0.07	0.04	0.08
60 (5.0)	1800	0.08	0.04	0.09
	1900	0.09	0.05	0.10
	2000	0.09	0.05	0.11
	1100	0.02	0.02	0.04
	1200	0.03	0.02	0.04
	1300	0.04	0.02	0.05
	1400	0.05	0.03	0.05
	1500	0.06	0.04	0.06
	1600	0.07	0.04	0.07
1700	0.07	0.04	0.08	

1. The pressure drop through the economizer is greater for 100% outdoor air than for 100% return air. If the resistance of the return air duct is less than 0.25 IWG, the unit delivers less CFM during full economizer operation.

Note: Filter pressure drop based on standard filter media tested at velocities not to exceed 300 ft/min.

BOTTOM DUCT DIMENSIONS (in.)

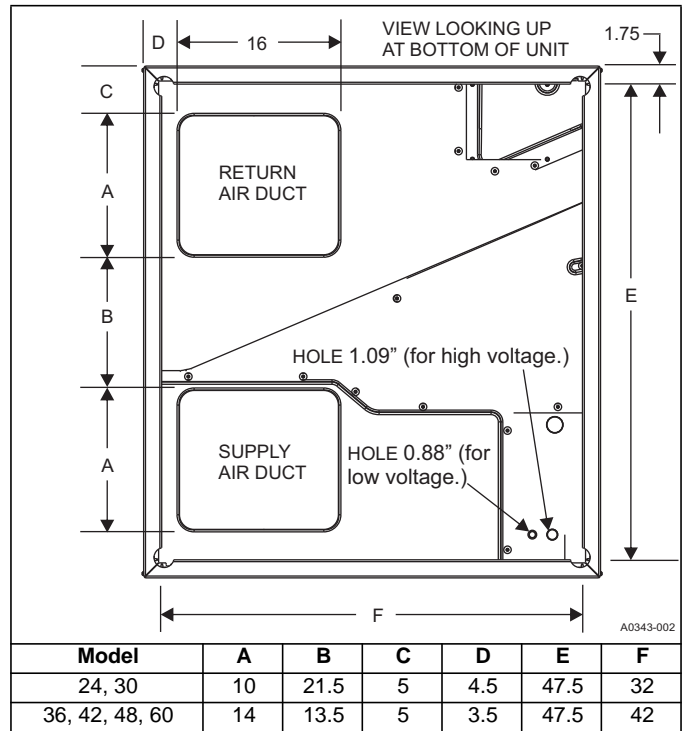

REAR DUCT DIMENSIONS (in.)

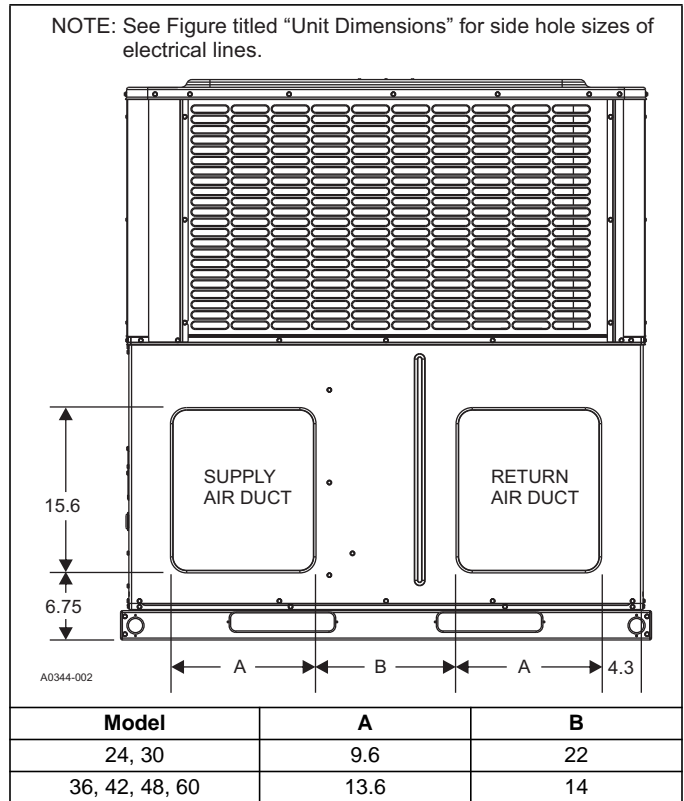

UNIT TYPICAL DUCT APPLICATIONS

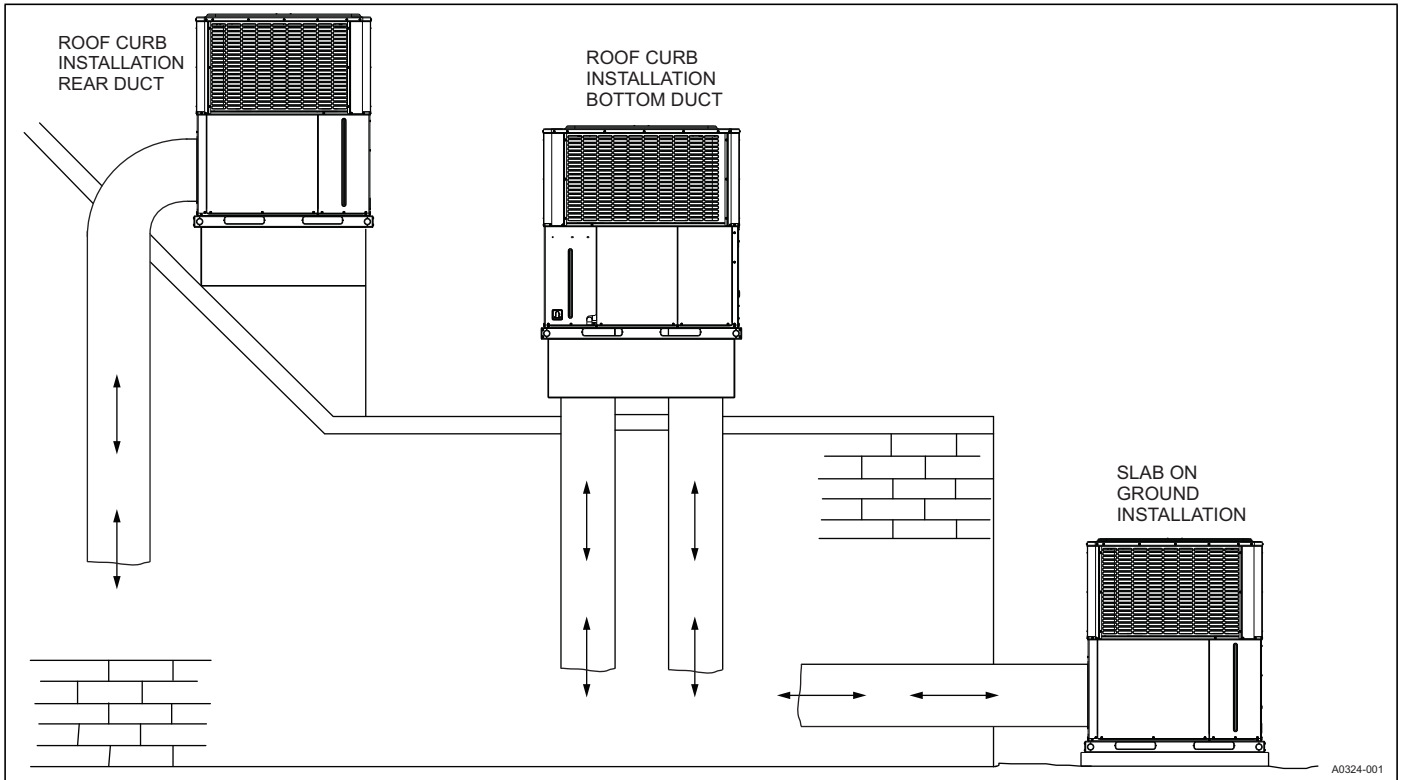

UNIT TYPICAL SLAB ON GROUND INSTALLATION

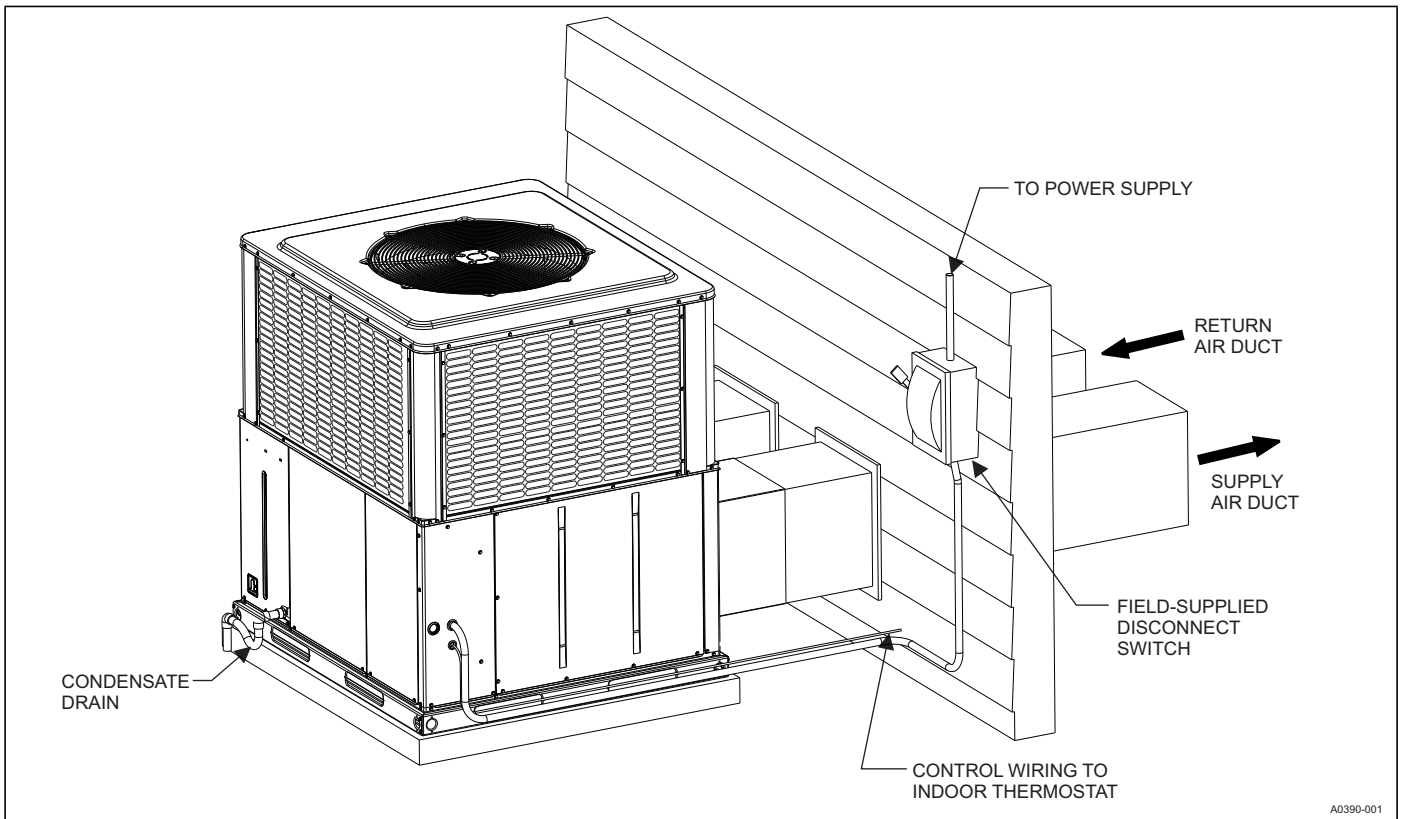

UNIT TYPICAL ROOF CURB INSTALLATION

