



TECHNICAL GUIDE

**SINGLE PACKAGE
AIR CONDITIONER/GAS HEAT
14 SEER - R-410A - 3 PHASE
3 TO 5 NOMINAL TONS - 460 V
50 TO 125 MBH HEAT INPUT
MODELS: PCG4*36 TO 60**



DESCRIPTION

These packaged cooling/heating air conditioners are designed for outdoor installation. Only utility and duct connections are required at the point of installation.

FEATURES

- **Operating Efficiency** - All PCG4 model gas units provide a minimum AFUE of 81.0% in heating and 14.0 SEER, 11.0 EER rating for cooling operation. All models meet California Low-Nox requirements of 40 ng/J emission level for Air Quality Management Districts.
- **On-Site Flexibility** - All model sizes use a compact design cabinet in one of two footprints. This provides installer flexibility for placing the proper capacity unit on curbs or pads with the smallest footprint after the internal load has been determined. Field convertible duct connections from side shot to down shot allow the installer to have greater flexibility with less inventory.
- **Lower Installation Cost** - Installation time and costs are reduced by easy power and control wiring connections. The small base dimension means less space is required on the ground or roof. All units are completely wired, charged with R-410A, and tested prior to shipment. Test stations using a state-of-the-art computerized process system are used to ensure product quality. Refrigerant charge and component part numbers are verified using computers during assembly. Vital run test statistics such as system pressure, motor currents, air velocity and temperature, unit vibration, and gas system safeties are monitored and recorded by the system to ensure unit performance. Equal size side supply and return duct connections allow easy connection of ducts to match low crawl spaces without transition pieces.
- **Utility Connections Made Easy** - Gas and electric utility access is provided through the bottom or side of the unit. Utility connections can be made quickly and with a minimum amount of field labor. A field supplied and field installed electrical disconnect switch must be installed.
- **Convertible Airflow Design** - The bottom duct openings are covered when they leave the factory, ready to be used for a side supply/side return application. If a bottom supply/bottom return application is required, remove the two panels from the bottom of the unit and place them in the side supply/side return duct openings. No panel cutting is required and no accessory panel is necessary. Convertible airflow design allows maximum field flexibility and minimum inventory.
- **Condensate Pan** - A corrosion-resistant, long-lasting, water-tight pan is positioned below the indoor coil to collect and drain all condensate, preventing buildup of stagnant condensate. The condensate pan conforms to ASHRAE 62-89 standards (Ventilation for Acceptable Indoor Air Quality).
- **Condensate Drain** - The 3/4 in. NPT female connection is rigidly mounted to ensure proper fit and leak tight seal.
- **Durable Finish** - The cabinet is made of G90 galvanized steel with a powder paint coating for appearance and protection. The pre-treated galvanized steel provides a better paint-to-steel bond, which resists corrosion and rust creep. Powder paint finish ensures less fading when exposed to sunlight, and provides superior corrosion resistance (1000 hour salt spray tested).

Due to continuous product improvement, specifications are subject to change without notice.

Visit us on the web at

www.simplygettingthejobdone.com and
www.york.com

Additional rating information can be found at

www.ahridirectory.org

WARRANTY SUMMARY*

Standard 1-Year limited parts warranty.
Standard 5-Years limited compressor warranty.
Lifetime gas heat exchanger warranty with registration.
See limited warranty certificate in User's Information Manual for details.

Continued on next page.

- **Outdoor Coil Grille** - All models utilize a stamped slotted design that provides superior impact protection against small objects during transit and after installation.
- **Full Perimeter Base Rails** - The easily removable base rails provide a solid foundation for the entire unit and protect the unit during shipment. The rails provide forklift access from all sides, and rigging holes are also provided so an overhead crane can be used to place the units on a roof. On applications where the unit is placed on a pad, the base keeps the unit off the pad to deter corrosion. On applications where height is limited, the base rails may be removed by removing two screws in each corner.
- **More Attractive Appearance** - A single-piece top cover containing a top-discharge outdoor fan arrangement requires less square footage on installation and provides a wider variety of installations. The one-piece design adds greater water integrity. Rounded corners with water drip edges add to the attractive appearance.
- **Top Discharge** - The top-discharge outdoor fan does not disrupt neighboring areas or dry out vegetation surrounding the unit. The warm air from the top mounted fan is blown up and away from the structure and any landscaping. This allows compact location on multi-unit applications.
- **Low Operating Sound Level** - The upward airflow carries the normal operating noise up and away from the living area. The rigid top panel effectively isolates noise. Isolator mounted compressor and the rippled fins of the outdoor coil muffle the normal fan motor and compressor operating sounds. The unique formed base pan also aids in sound attenuation with its structural design. This design strategically places embossments in the pan for optimum strength and rigidity.
- **Fan System** - All models operate over a wide range of design conditions with a standard ECM indoor fan motor. These units easily match all types of applications and provide greater on-site flexibility to match comfort requirements. The cooling speed is factory-set and can be field-adjusted to a second speed. The heating speed is factory-set to maintain mid point rise at the units' heating input, but can be field adjusted. This allows maximum comfort conditions.
- **Simple Control Circuit** - A low voltage gas heat printed circuit board contains a status/diagnostic indicator light. Field thermostat wiring connects to color coded wire leads using twist on wire connections. Cooling controls use contactor and relays for simple application and troubleshooting. Mate-n-lock plug connectors are used. The electrical control box is not located in the compressor compartment. The controls are mounted to allow the separate access panel to be removed for troubleshooting and maintenance without affecting the normal system operating pressures. All wiring internal to the unit is color/number coded.
- **Protected Compressor** - The compressor is internally protected against high pressure and temperature. This is accomplished by the simultaneous operation of a high pressure relief valve and a temperature sensor, which protects the compressor if undesirable operating conditions occur.
- **Pressure Switches** - A high pressure switch is standard in all units. When abnormal conditions are sensed through the pressure switch, the unit locks out, preventing any further operation until it is reset or the problem is corrected.
- **Exclusive Coil Design** - The grooved copper tubes and enhanced aluminum fin construction of the indoor coils improve heat transfer for maximum efficiency and durability. Indoor coils have tin-coated copper tubing with aluminum fins for effective heat transfer. PCG4B48 and PCG4B60 models have tube and fin outdoor coils that provide efficient heat transfer. PCG4A36 models have non-galvanic micro-channel outdoor coils that enhance efficiencies and reduce unit size and charge levels.
- **Heat Exchangers** - Gas heat exchangers use corrosion-resistant, stainless-steel tubular construction to provide long-life, trouble-free operation. Gas heat exchangers are offered with lifetime warranties as standard with registration.
- **Post Purge Induced Draft Combustion** - Exhausts combustion products from the heat exchanger upon completion of the heating cycle to prolong the heat exchanger life.
- **Spark To Burner Ignition** - No pilot assembly required, which provides more consistent ignition in gas heating mode. This ignition is highly reliable, durable, and eliminates nuisance lockouts.
- **Multi Port In-Shot Burners** - No field adjustment is required to mix the air and gas for natural gas or propane use. These burners are constructed of high-grade corrosion-resistant, aluminized steel.
- **Low Maintenance** - Long life, permanently lubricated outdoor and indoor fan motor bearings need no annual maintenance, adding greater reliability to the unit. Slide-out blower assembly can be easily removed for cleaning.
- **Easy Service Access** - Individual access panels covering the electrical and gas controls make servicing easy. Removing these panels allows easy removal of components such as the blower assembly for maintenance and troubleshooting.
- **Replacement Parts** - The installer requires no special training to replace any of the components of these units. The number of new components has been reduced to minimize the inventory of unique parts.
- **Filter Frame Kit** - All 3 phase units include a filter frame kit, which is shipped inside the unit from production. Field installation is required.
- **Filters** - All 3 phase units include an applicable number of 1 in. washable filters, which are shipped inside the unit from production. Field installation is required. Two filters are required for A base units. Three filters are required for B base units.

NOMENCLATURE

PCG	4	B	48	100	4	X	1	A
1	2	3	4	5	6	7	8	9
1. Model Family PCG - packaged A/C with gas heat PCE - packaged A/C with electric heat PHE - packaged heat pump with electric heat PHG - packaged heat pump with gas heat 2. Nominal Cooling Efficiency 4 = 14 SEER, 6 = 16 SEER 3. Cabinet Size A = small 35 x 51, B = large 45 x 51 4. Nominal Air Conditioning Cooling Capacity 48 = Nominal Capacity, etc. Examples: PCG4B481004X1A is a packaged A/C with gas heat, 14 SEER, large cabinet, 4 ton, single-stage heat, 100,000 BTU gas heat, 460 V, three-phase, low-NOx model, first generation, first release.					5. Gas Heating Input BTU/Hr x 1000 050 = 50,000 BTU/Hr. input, blank = electric heat 6. Voltage-Phase-Frequency 2 = 208/230-1-60, 3 = 208/230-3-60, 4 = 460-3-60 7. NOx Approval X = low-NOx, blank = not low-NOx 8. Generation Level 1 = first generation, etc. 9. Revision Level A = original release, B = second release			

COMPONENT LOCATION

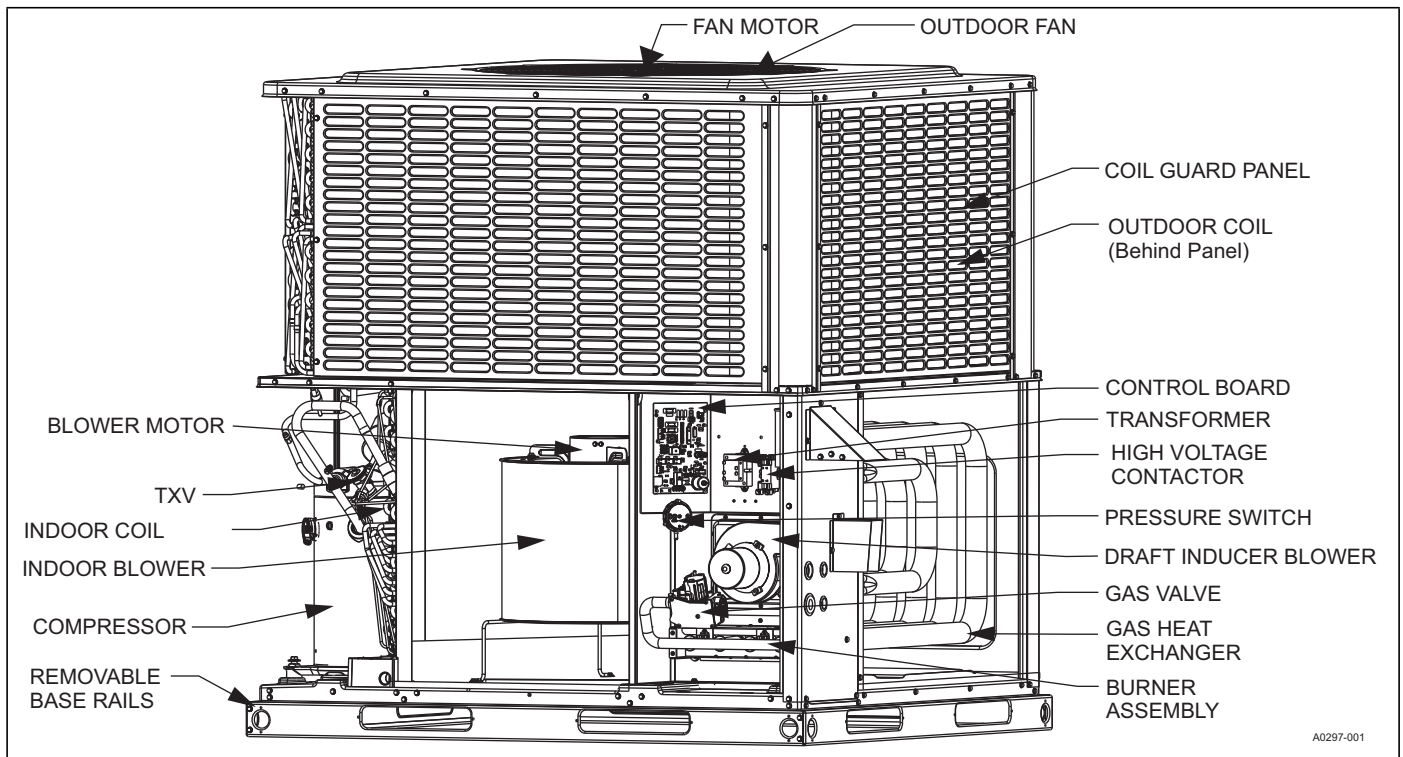

Note: PCG4B48 and PCG4B60 models have tube and fin outdoor coils as shown in the figure above. PCG4A36 models have microchannel outdoor coils.

UNIT LIMITATIONS

Model	Unit Voltage	Unit Limitations		
		Applied Voltage		Outdoor DB Temp
		Minimum	Maximum	Maximum (°F)
PCG4A36	460-3-60	432	504	125
PCG4B48				
PCG4B60				

APPLICATIONS AND ACCESSORIES

Packaged Equipment Series	Application Limitations			
	Air Temperature at Outdoor Coil (°F)		Air Temperature at Indoor Coil (°F)	
	Minimum	Maximum	Minimum	Maximum
	DB Cool	DB Cool	WB Cool	WB Cool
14 SEER AC	55	125	57	72

- **Anchor Bracket Kit (S1-1HK0601)** - This kit firmly anchors PCG, PCE, PHE, and PHG packaged units to a pad or support structure. When properly installed, the kit is approved for ground-mounted or roof-mounted applications, wind load certified, and listed with the State of Florida. See <https://floridabuilding.org> for this listing.
- **Propane Conversion Kit (S1-1NP0703, S1-1NP0704)** - Kit includes burner orifices, gas valve conversion, and installation instructions necessary to field convert unit from natural gas to propane.
- **Economizer for Downflow Applications (S1-2EE04710024, S1-2EE04710124)** - Modulating integrated economizer provides simultaneous operation between the mechanical cooling and economizer operation. Independent blade design ensures proper control and less than 1% leak rate. Includes hood and mesh bird screen filter integrated into the hood, dry bulb sensor, and barometric relief damper. Separate field accessories of single enthalpy and dual enthalpy are also available.
- **Economizer for Horizontal Applications (S1-2EE04710224, S1-2EE04710324)** - Modulating integrated economizer provides simultaneous operation between the mechanical cooling and economizer operation. Independent blade design ensures proper control and less than 1% leak rate. Includes hood and mesh bird screen filter integrated into the hood and dry bulb sensor. Separate field accessories of single enthalpy and dual enthalpy are also available.
- **Barometric Relief Hood (S1-1RD0501)** - Used in conjunction with a horizontal economizer, the Barometric Relief Hood helps to equalize the building pressure that is caused by the fresh air that is introduced through the economizer fresh air hood.
- **Single/Dual Enthalpy Sensor (S1-HE-69630NS-2D)** - Sensor replaces dry bulb sensor standard in economizer kit. Provides improved economizer operation by sensing the dry bulb temperature from outdoors plus the enthalpy content of the outdoor air.
- **Duct/Unit Mount CO2 Kit (S1-2AQ04700924)** - Sensor kit detects CO2 levels automatically and overrides the economizer when CO2 levels rise above the preset limits.
- **Wall Mount CO2 Kit (S1-2AQ04701024)** - Sensor kit detects CO2 levels automatically and overrides the economizer when CO2 levels rise above the preset limits.
- **Supply Air Temperature Sensor Kit (S1-TE-63616E-2D)** - Outdoor supply air temperature sensor kit used with economizers.
- **Filter/Frame Kit (Kit provided) (S1-1FF0602, S1-1FF0601)** - Kit contains the necessary hardware to field install return air filters into the base unit. The filter rack is suitable for 1 in. or 2 in. filters.
- **Filter (S1-02647812000)** - Washable 1 in. filter. Two filters are required for A base units. Three filters are required for B base units. Washable filters are included inside shipped units for field installation.
- **Motorized Fresh Air Damper (S1-2MD04705224, S1-2MD04705124)** - Designed for duct mounted side supply/return and unit mounted down supply/return applications. Damper capable of providing 0% to 50% of outdoor air (field supplied). Closes on power loss, and includes hood and screen assembly.
- **Loss of Charge Switch (S1-2LC00024)** - Kit provides Loss of Charge switch and wiring to provide safe shutdown of compressor.
- **Rectangle to Round (Horizontal) Adapter (S1-1AK0110, S1-1AK0111)** - Kit includes one supply and one return air rectangle to round duct adapter. Adapters are preformed and designed to fit over current horizontal duct openings on the base unit. Transition is from rectangle to 12 in. round for the 1AK0110 kit and from rectangle to 14 in. round for the 1AK0111 kit.
- **Rectangle to Round (Downflow) Adapter (S1-1AK0108, S1-1AK0109)** - Kit includes one supply and one return air rectangle to round duct adapter. Adapters are preformed and designed to fit into current downflow duct openings on the roof curb. Transition is from rectangle to 16 in. round for the 1AK0108 kit and from rectangle to 18 in. round for the 1AK0109 kit.
- **Roof Curbs (S1-1RC0503, S1-1RC0501)** - NRCA approved curbs provide proper fit to base unit for rooftop installations. Curbs are designed to be assembled through hinge pins in each corner. Kit also provides seal strip to ensure an airtight seal. These are 8 in. high roof curbs.
- **Roof Curbs (S1-1RC0504, S1-1RC0502)** - NRCA approved curbs provide proper fit to base unit for rooftop installations. Curbs are designed to be assembled through hinge pins in each corner. Kit also provides seal strip to ensure an airtight seal. These are 14 in. high roof curbs.
- **Transition Curb Kits (S1-1TC01*)** - Adapter kits to allow field use of pre-existing installed roof curbs to match PCG4 footprint to Affinity roof curbs, Carrier, Trane, or Goodman curb footprints. Curb adapters are optional for current generation Carrier replacements, but are recommended for previous generation applications. Refer to the PCG4 price pages for more details.
- **Manual Outdoor Damper (S1-1FA0502, S1-1FA0501)** - Provides 0% to 50% outdoor air capability (field adjustable). Designed for duct mounted side supply/return applications. Includes hood and screen assembly.
- **Thermostat** - Compatible thermostat controls are available through accessory sourcing. For optimum performance, these outdoor units are fully compatible with our residential Hx™ Touch Screen Thermostat available through Source 1. For more information, refer to the thermostat section of the Product Equipment Catalog.
- **Wall Thermostat** - The units are designed to operate with standard, 24 V electronic and electromechanical thermostats. All units can operate with single stage heat/single stage cool thermostats - with or without the economizer.
- **Low Ambient Kit (S1-2LA04701024)** - Kit provides necessary hardware to convert unit to operate in cooling cycle down to 0°F. Standard unit operation 45°F.
- **Base Rail Hole Cover Kit (S1-1HC0101)** - Kit provides necessary hardware to close off openings in base rails to block off openings, that is, prevent animal entrance.

GUIDE SPECIFICATIONS

GENERAL

Units shall be manufactured by Ducted Systems in an ISO 9001 certified facility. Packaged units give you the flexibility and choice you need in today's market. These packaged cooling/heating air conditioners are designed for outdoor installation. Only utility and duct connections are required at the point of installation. The single-stage gas fired heaters have stainless steel tubular heat exchangers and spark to burner ignition. They are available in natural gas with field conversion to propane.

DESCRIPTION

Units shall be factory-assembled, single packaged, Electric Cooling/Gas Heating units, designed for outdoor installation. For SEER ratings, refer to the technical literature. They shall have built-in, equal size, field convertible duct connections for supply/return or horizontal supply/return. The units shall be factory wired, piped, charged with R-410A refrigerant, and factory tested prior to shipment. All unit wiring shall be both numbered and color coded. All models shall be rated in accordance with DOE and AHRI test procedures for both heating and cooling operation. Units shall be CSA listed and classified to ANSI Z21.47/CAN/ CSA 2.3 standards and UL 1995/CAN/CSA No. 236-M90 standards.

UNIT CABINET

Unit cabinet shall be constructed of G-90 galvanized, powder-painted steel, certified at 1000 hours salt spray test per ASTM-B117 standards. The unit top shall be a single piece design, with drip edges and no-seam corners to provide optimum water integrity. Unit shall have a rigidly mounted outdoor coil guard to provide protection from objects and personnel after installation. Indoor blower section shall be insulated with foil-faced or foam insulation, fastened to prevent insulation from entering the air stream. Cabinet panels shall be separate and easily removable for servicing and maintenance. Unit shall be built on a formed, design base pan, with embossments at critical points to add strength and rigidity and aid in minimizing sound. Full perimeter base rails shall be provided to ensure reliable transit of equipment and facilitate overhead rigging, allowing truck access and proper sealing on roof curb applications. Base rails shall be easily removable when required to lower unit height. Filters shall be field installed, furnished, and accessible through a removable access door, sealed airtight. The unit's vertical discharge and return duct configuration shall be designed to fit between standard 24 in. O.C. beams without modification to building structure, duct work, and base unit. Condensate pan shall be internally sloped and conform to ASHRAE 62-89 self-draining standards, with 3/4 in. NPT female ridged mount connection.

Indoor Blower Assembly - Fan shall be direct drive design. Fan wheel shall be double-inlet type with forward-curved blades, dynamically balanced to operate smoothly throughout the entire range of operation. Airflow design shall be constant air volume. Bearings shall be sealed and permanently lubricated for longer life and no maintenance. Fan assembly shall be a slide-out design for easy removal and cleaning. Indoor blower motors shall be equipped with a standard high efficiency brushless DC motor (constant torque), also known as a standard ECM motor.

Outdoor Fan Assembly - The outdoor fan shall be of the direct-driven propeller type, discharge air vertically, have aluminum blades riveted to corrosion resistant steel spider bracket, and be statically balanced for smooth operation. The outdoor fan motor shall be totally enclosed with permanently lubricated bearings and internally protected against overload conditions.

REFRIGERANT COMPONENTS

Compressors:

- Shall be fully hermetic type, direct drive, internally protected with internal high-pressure relief and over temperature protection. The hermetic motor shall be suction gas cooled and have a voltage range of +/- 10% of the unit nameplate voltage.
- Shall have internal isolation and sound muffling to minimize vibration and noise, and be externally isolated on a dedicated, independent mounting.

Coils:

- Indoor coils shall have aluminum plate fins mechanically bonded to seamless internally enhanced tin-coated copper tubes with all joints brazed.
- Indoor coil shall be of the direct expansion, draw through design.
- Outdoor coils shall have aluminum plate fins mechanically bonded to seamless aluminum microchannels or internally enhanced copper tubes with all joints brazed.
- Outdoor coil shall be draw through design.

Refrigerant Circuit and Refrigerant Safety Components shall include:

- Thermal expansion devices (TXV's) that are factory mounted and provided
- Filter/strainer to eliminate any foreign matter

GAS HEATING SECTION

Heat exchanger and exhaust system shall be constructed of corrosion-resistant materials and shall be designed with induced draft combustion with post purge logic and redundant main gas valve. The heat exchanger shall be of the tubular type, constructed of stainless steel for corrosion resistance and allowing minimum mixed air entering temperature of 40°F. Burners shall be of the in-shot type, constructed of aluminumized steel. All gas piping shall enter the unit cabinet at a single location through either the side or bottom, without any field modifications. An integrated control board shall provide timed control of indoor fan functioning and burner ignition. Heating section shall be provided with the following minimum protection:

- Primary high-temperature limit switch
- Induced draft pressure switch
- Flame roll out switch(s) (manual reset)
- Flame proving controls

All gas heat models meet the California requirement for emissions of less than 40 ng/J.

PHYSICAL DATA

COMPONENT	MODELS								
	PCG4A36			PCG4B48			PCG4B60		
NOMINAL TONNAGE	3.0			4.0			5.0		
AHRI cooling performance									
Gross capacity @ AHRI A point (MBH)	37.3			47.7			55.0		
AHRI net capacity (MBH)	36.4			45.5			52.5		
EER	11.0			11.0			11.0		
SEER	14.0			14.0			14.0		
Nominal CFM	1185			1600			2000		
System power (kW)	2.8			4.2			4.8		
Refrigerant type	R-410A			R-410A			R-410A		
Refrigerant charge (lb-oz)	3-9			11-3			12-0		
AHRI gas heat performance									
Heating model	50	75	100	65	100	125	65	100	125
Heat input (KBTU)	50.0	75.0	100.0	65.0	100.0	125.0	65.0	100.0	125.0
Heat output (KBTU)	40	60	80	52	80	100	52	80	100
AFUE (%)	81.0	81.0	81.0	81.0	81.0	81.0	81.0	81.0	81.0
Number of burners	2	3	4	2	3	4	2	3	4
Number of stages	1	1	1	1	1	1	1	1	1
Temperature rise range (°F)	35-65	40-70		40-70			40-70		
Maximum static pressure W.C.	0.5			0.5			0.5		
Maximum outlet air temperature (°F)	180			180			180		
Gas piping connection (in.)	1/2			1/2			1/2		
Dimensions (in.)									
Length	51-1/4			51-1/4			51-1/4		
Width	35-3/4			45-3/4			45-3/4		
Height	45			49			51		
Operating weight (lb)	349	356	360	460	468	473	477	481	488
Compressors									
Type	Scroll			Scroll			Scroll		
Outdoor coil data									
Face area (sq ft)	13.4			19.5			21.5		
Rows	1			2			2		
Fins per inch	23			22			22		
Tube diameter	0.051 x 0.63			3/8			3/8		
Circuitry type	Microchannel			Interlaced			Interlaced		
Indoor coil data									
Face area (sq ft)	4.6			6.3			6.3		
Rows	3			3			3		
Fins per inch	16			16			16		
Tube diameter	3/8			3/8			3/8		
Circuitry type	Interlaced			Interlaced			Interlaced		
Refrigerant control	TXV			TXV			TXV		
Outdoor fan data									
Fan diameter (in.)	24			26			26		
Type	Prop			Prop			Prop		
Drive type	Direct			Direct			Direct		
Number of speeds	1			1			1		
Motor HP each	1/4			1/3			1/3		
RPM	850			850			850		
Nominal total CFM	2400			3200			3200		
Direct drive indoor fan data									
Fan size (in)	11 x 10			11 x 10			11 x 10		
Type	Centrifugal			Centrifugal			Centrifugal		
Motor HP each	1/2	1		1			1		
RPM	1200 Maximum			1200 Maximum			1200 Maximum		
Frame size	48			48			48		
Filters									
Filter size	A			B			B		
Quantity - size	Field-supplied external filters must be sized so as not to exceed 300 FPM air velocity through disposable filters. All three phase models include an internal filter rack kit and washable filters. Consult the instructions supplied with the kit for replacement filter sizes. Filter sizes: A = 20 x 20, B = 20 x 30								

COOLING PERFORMANCE DATA - 3 TON																
PACKAGED UNIT MODEL NO.		PCG4A36														
CONDENSER ENTERING AIR TEMPERATURE	ID CFM	1000					1200					1400				
	IDDB	80	80	75	80	80	80	80	75	80	80	80	80	80	80	80
	IDWB	57	62	62	67	72	57	62	62	67	72	57	62	62	67	72
55 / 45	T.C.	36.0	38.3	40.3	44.9	48.1	38.9	40.4	42.1	46.8	49.8	41.8	42.5	43.9	48.8	51.5
	S.C.	34.5	30.6	27.6	27.9	22.6	37.1	33.8	29.9	30.2	23.9	39.6	37.1	32.2	32.5	25.1
	K.W.	1.82	1.83	1.83	1.83	1.85	1.89	1.90	1.90	1.91	1.92	1.97	1.97	1.98	1.99	1.99
65 / 55	T.C.	34.6	36.4	37.4	42.6	46.1	37.3	38.3	39.4	44.2	47.9	40.0	40.2	41.3	45.9	49.8
	S.C.	33.2	29.8	26.0	26.8	21.6	35.6	32.9	28.5	28.9	23.4	37.9	36.1	31.0	31.1	25.1
	K.W.	2.01	2.02	2.02	2.03	2.04	2.09	2.09	2.09	2.10	2.11	2.16	2.16	2.17	2.18	2.19
75 / 63	T.C.	33.2	34.6	34.5	40.3	44.0	35.7	36.3	36.6	41.7	46.1	38.1	37.9	38.7	43.1	48.2
	S.C.	32.0	28.9	24.5	25.7	20.7	34.1	32.0	27.2	27.7	22.9	36.1	35.2	29.9	29.7	25.0
	K.W.	2.20	2.20	2.21	2.22	2.23	2.28	2.28	2.28	2.30	2.30	2.36	2.36	2.36	2.37	2.38
85 / 69	T.C.	31.7	32.6	32.2	37.8	41.2	34.0	34.0	33.8	38.9	42.8	36.3	35.4	35.4	40.1	44.5
	S.C.	30.4	26.9	23.3	24.6	19.3	32.4	30.3	25.8	26.5	21.1	34.5	33.7	28.2	28.4	22.8
	K.W.	2.46	2.44	2.47	2.48	2.49	2.53	2.53	2.54	2.55	2.56	2.61	2.61	2.61	2.63	2.63
95 / 75	T.C.	30.1	30.6	29.8	35.3	38.4	32.3	31.7	31.0	36.2	39.6	34.5	32.8	32.1	37.1	40.8
	S.C.	28.8	25.0	22.2	23.4	17.9	30.8	28.6	24.3	25.3	19.3	32.8	32.2	26.5	27.2	20.7
	K.W.	2.72	2.67	2.73	2.74	2.74	2.79	2.77	2.80	2.81	2.82	2.87	2.87	2.87	2.88	2.89
105 / 83	T.C.	29.0	28.3	27.8	32.8	36.1	31.1	29.6	28.9	33.8	37.1	33.3	30.8	29.9	34.7	38.1
	S.C.	27.5	23.9	20.9	21.8	16.9	29.4	27.1	22.9	23.8	18.2	31.3	30.4	25.0	25.8	19.6
	K.W.	2.91	2.92	2.95	2.96	2.97	2.95	3.01	3.02	3.04	3.05	2.98	3.10	3.10	3.11	3.12
115 / 89	T.C.	27.9	26.0	25.9	30.4	33.9	30.0	27.4	26.8	31.4	34.7	32.1	28.9	27.8	32.3	35.5
	S.C.	26.3	22.9	19.6	20.3	15.9	28.1	25.8	21.6	22.3	17.2	29.9	28.6	23.5	24.4	18.5
	K.W.	3.11	3.16	3.17	3.19	3.20	3.10	3.24	3.24	3.26	3.27	3.10	3.32	3.32	3.33	3.35
125 / 95	T.C.	26.8	23.8	24.0	28.0	31.7	28.9	25.3	24.8	29.0	32.3	31.0	26.9	25.6	30.0	33.0
	S.C.	25.1	21.9	18.3	18.7	14.9	26.8	24.4	20.2	20.9	16.2	28.5	26.9	22.1	23.1	17.4
	K.W.	3.30	3.39	3.39	3.41	3.42	3.25	3.47	3.46	3.48	3.49	3.21	3.55	3.54	3.55	3.57

COOLING PERFORMANCE DATA - 4 TON																	
PACKAGED UNIT MODEL NO.		PCG4B48															
CONDENSER ENTERING AIR TEMPERATURE	ID CFM	1400					1600					1800					
	IDDB	80	80	75	80	80	80	80	75	80	80	80	80	80	75	80	80
	IDWB	57	62	62	67	72	57	62	62	67	72	57	62	62	67	72	
55 / 45	T.C.	50.7	55.0	54.4	59.4	65.3	53.0	56.8	56.1	61.2	67.2	55.4	58.6	57.9	63.1	69.1	
	S.C.	48.2	44.8	38.3	38.5	30.4	49.3	48.2	41.0	40.7	31.9	50.3	51.5	43.6	42.9	33.4	
	K.W.	2.48	2.52	2.51	2.54	2.56	2.56	2.59	2.58	2.61	2.62	2.64	2.65	2.64	2.67	2.68	
65 / 55	T.C.	48.0	52.0	51.2	57.1	62.8	50.3	53.6	52.9	58.7	64.4	52.5	55.2	54.5	60.3	66.0	
	S.C.	44.3	43.2	36.7	37.1	29.6	46.3	46.6	39.3	39.4	30.8	48.4	50.0	41.9	41.7	32.1	
	K.W.	2.76	2.79	2.79	2.81	2.83	2.83	2.85	2.85	2.88	2.89	2.90	2.92	2.91	2.94	2.95	
75 / 63	T.C.	45.4	49.0	48.1	54.9	60.3	47.5	50.4	49.6	56.2	61.6	49.6	51.8	51.1	57.5	62.9	
	S.C.	40.3	41.7	35.0	35.7	28.7	43.4	45.1	37.6	38.1	29.7	46.4	48.4	40.2	40.5	30.8	
	K.W.	3.04	3.06	3.06	3.08	3.11	3.10	3.12	3.12	3.14	3.17	3.16	3.18	3.18	3.21	3.23	
85 / 69	T.C.	42.9	45.4	44.9	51.3	56.4	44.8	46.6	46.1	52.5	57.7	46.7	47.7	47.2	53.6	59.1	
	S.C.	38.3	39.8	33.2	33.7	27.3	41.4	42.4	35.7	36.3	28.4	44.4	44.9	38.2	38.9	29.4	
	K.W.	3.41	3.42	3.42	3.44	3.46	3.47	3.49	3.48	3.50	3.53	3.53	3.55	3.54	3.57	3.59	
95 / 75	T.C.	40.4	41.8	41.7	47.7	52.4	42.1	42.7	42.6	48.7	53.8	43.9	43.6	43.4	49.7	55.2	
	S.C.	36.4	38.0	31.4	31.8	25.9	39.4	39.7	33.8	34.5	27.0	42.4	41.4	36.2	37.3	28.1	
	K.W.	3.79	3.79	3.78	3.80	3.82	3.85	3.85	3.83	3.86	3.89	3.90	3.91	3.89	3.92	3.95	
105 / 83	T.C.	36.7	37.6	37.5	43.5	47.8	38.1	38.4	38.0	44.3	48.9	39.5	39.2	38.6	45.1	50.0	
	S.C.	32.3	34.7	29.7	30.0	23.9	34.3	36.1	31.1	32.6	24.9	36.4	37.4	32.6	35.1	26.0	
	K.W.	4.30	4.30	4.29	4.32	4.34	4.36	4.36	4.35	4.38	4.41	4.43	4.42	4.41	4.44	4.47	
115 / 89	T.C.	33.1	33.6	33.3	39.4	43.4	34.1	34.3	33.6	40.0	44.2	35.2	35.0	33.8	40.6	45.0	
	S.C.	28.4	31.6	28.0	28.4	21.9	29.4	32.5	28.6	30.7	22.9	30.5	33.5	29.1	33.0	23.9	
	K.W.	4.80	4.80	4.79	4.83	4.85	4.87	4.86	4.86	4.89	4.91	4.93	4.92	4.92	4.95	4.97	
125 / 95	T.C.	29.5	29.5	29.2	35.3	39.0	30.2	30.1	29.2	35.7	39.5	30.9	30.7	29.1	36.1	40.0	
	S.C.	24.5	28.4	26.4	26.7	19.9	24.5	29.0	26.0	28.8	20.9	24.6	29.6	25.6	31.0	21.9	
	K.W.	5.30	5.29	5.30	5.33	5.35	5.37	5.36	5.36	5.39	5.41	5.44	5.42	5.42	5.45	5.47	

COOLING PERFORMANCE DATA - 5 TON																
PACKAGED UNIT MODEL NO.		PCG4B60														
CONDENSER ENTERING AIR TEMPERATURE	ID CFM	1600					1800					2000				
	IDDB	80	80	75	80	80	80	80	75	80	80	80	80	75	80	80
	IDWB	57	62	62	67	72	57	62	62	67	72	57	62	62	67	72
55 / 45	T.C.	68.0	69.1	68.1	73.0	79.5	70.4	70.4	69.3	74.8	80.8	72.7	71.7	70.5	76.6	82.2
	S.C.	63.3	54.8	46.2	43.7	36.0	66.7	57.0	48.8	46.3	37.1	70.1	59.2	51.4	48.8	38.2
	K.W.	2.93	2.97	2.97	3.00	3.03	3.15	3.17	3.18	3.21	3.24	3.36	3.38	3.38	3.42	3.45
65 / 55	T.C.	64.1	65.4	64.3	69.7	75.7	66.2	66.4	65.1	71.0	76.5	68.4	67.5	65.9	72.3	77.4
	S.C.	60.3	53.4	44.6	43.2	34.9	62.8	55.9	46.7	45.4	35.7	65.3	58.3	48.9	47.6	36.5
	K.W.	3.25	3.27	3.28	3.31	3.35	3.46	3.48	3.49	3.52	3.56	3.68	3.69	3.69	3.73	3.77
75 / 63	T.C.	60.2	61.8	60.5	66.4	72.0	62.1	62.5	60.9	67.1	72.2	64.0	63.2	61.4	67.9	72.5
	S.C.	57.4	52.0	43.1	42.7	33.7	59.0	54.7	44.7	44.5	34.3	60.6	57.5	46.3	46.3	34.9
	K.W.	3.56	3.58	3.59	3.63	3.67	3.78	3.79	3.80	3.84	3.88	3.99	4.00	4.01	4.04	4.08
85 / 69	T.C.	57.4	57.1	56.2	61.8	67.1	58.7	57.8	56.6	62.3	67.4	60.0	58.4	57.0	62.9	67.7
	S.C.	55.0	49.4	41.1	40.5	31.6	56.2	52.2	43.1	42.5	32.8	57.5	55.0	45.1	44.5	33.9
	K.W.	3.98	4.00	4.01	4.04	4.07	4.19	4.21	4.21	4.24	4.28	4.41	4.42	4.42	4.45	4.48
95 / 75	T.C.	54.5	52.4	52.0	57.1	62.3	55.3	53.0	52.3	57.5	62.6	56.1	53.7	52.5	57.9	62.9
	S.C.	52.6	46.9	39.2	38.2	29.4	53.5	49.7	41.5	40.4	31.2	54.4	52.5	43.8	42.6	33.0
	K.W.	4.40	4.42	4.42	4.44	4.48	4.61	4.62	4.62	4.65	4.68	4.82	4.83	4.83	4.86	4.88
105 / 83	T.C.	52.1	47.2	45.9	51.1	55.2	52.5	47.6	45.6	51.0	55.2	52.8	47.9	45.2	50.9	55.1
	S.C.	49.5	42.1	36.3	36.0	26.7	50.0	44.0	37.3	37.8	28.1	50.4	45.8	38.3	39.7	29.5
	K.W.	5.03	4.99	4.99	5.01	5.05	5.22	5.19	5.19	5.22	5.25	5.40	5.40	5.40	5.42	5.45
115 / 89	T.C.	49.8	42.2	40.0	45.3	48.3	49.8	42.3	39.0	44.7	47.9	49.7	42.3	38.1	44.0	47.5
	S.C.	46.6	37.5	33.4	33.8	24.0	46.6	38.4	33.3	35.3	25.0	46.6	39.4	33.1	36.9	26.0
	K.W.	5.65	5.54	5.54	5.57	5.60	5.80	5.75	5.74	5.77	5.80	5.96	5.95	5.95	5.97	6.00
125 / 95	T.C.	47.5	37.1	34.1	39.5	41.4	47.1	36.9	32.5	38.3	40.7	46.6	36.8	31.0	37.2	39.9
	S.C.	43.6	32.8	30.6	31.6	21.3	43.1	32.9	29.2	32.8	21.9	42.7	32.9	27.8	34.1	22.6
	K.W.	6.27	6.09	6.09	6.12	6.15	6.39	6.30	6.30	6.32	6.35	6.52	6.51	6.50	6.52	6.55

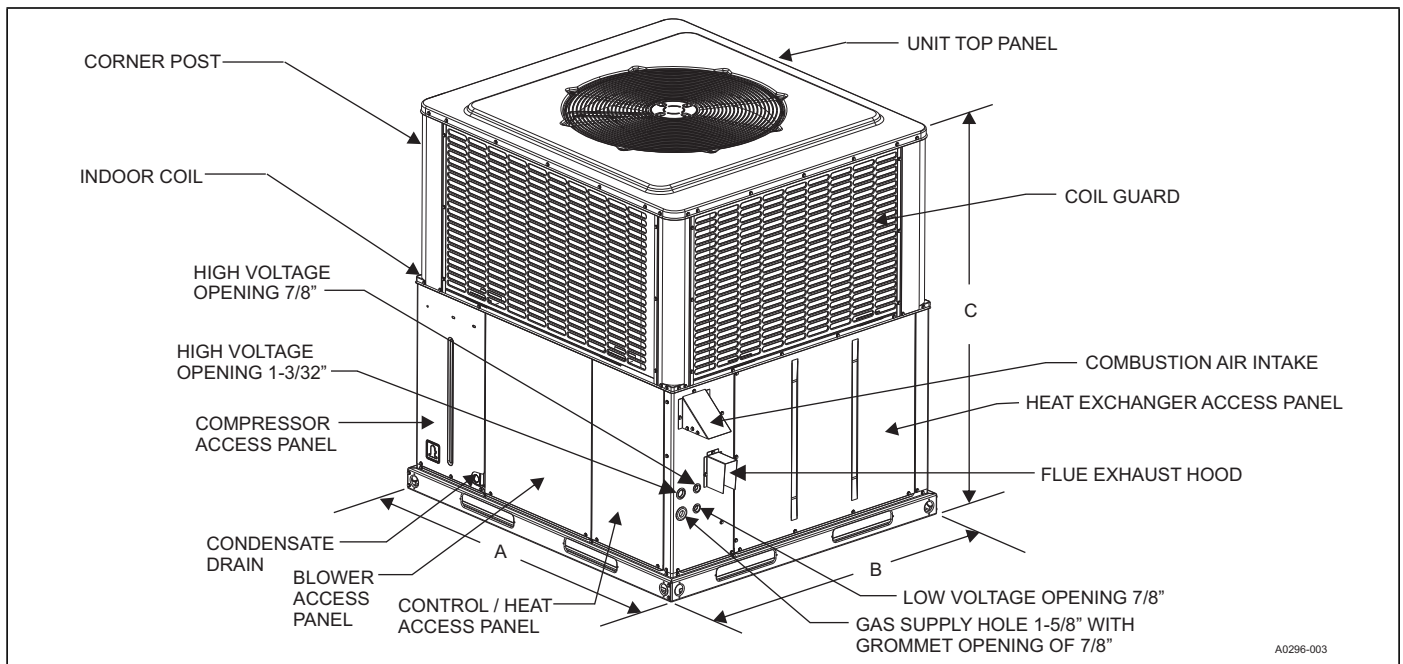

UNIT DIMENSIONS

Model	Dimensions (in.)		
	A	B	C
PCG4A36	51-1/4	35-3/4	45
PCG4B48		45-3/4	49
PCG4B60		45-3/4	51

UNIT CLEARANCES^{1,2}

Direction	Distance (in.)	Direction	Distance (in.)
Top ³	36	Power Entry (Right Side)	36
Side Opposite Ducts	36	Left Side	24
Duct Panel	0	Bottom ⁴	1

1. A 1 in. clearance must be provided between any combustible material and the supply air duct work.
2. The products of combustion must not be allowed to accumulate within a confined space and recirculate.
3. Units must be installed outdoors. Overhanging structure or shrubs must not obstruct outdoor air discharge outlet.
4. Units can be installed on combustible materials made from wood or class A, B, or C roof covering materials if factory base rails are left in place as shipped.

INDOOR BLOWER SPECIFICATIONS

Model	Motor				
	HP	RPM	EFF.	SF	Frame
PCG4A360504X3	1/2	Variable	0.8	1.0	48
PCG4A360754X3	1/2				
PCG4A361004X3	1				
PCG4B480654X2	1				
PCG4B481004X2	1				
PCG4B481254X2	1				
PCG4B600654X2	1				
PCG4B601004X2	1				
PCG4B601254X2	1				

SOUND PERFORMANCE

Model (Tons)	Sound Rating ¹ dB(A)	Octave Band Centerline Frequency (Hz)						
		125	250	500	1000	2000	4000	8000
PCG4A36	74	58.5	61.8	65.4	66.5	60.7	54.8	49.8
PCG4B48	74	63.5	63.9	62.3	65	64	54.1	46.6
PCG4B60	76	72.3	65.0	63.9	64	60	55.5	49.0

1. Rated in accordance with AHRI Standard 270.

ELECTRICAL DATA - 460-3-60

Model	Voltage	Compressor			Outdoor Fan Motor	Indoor Fan Blower Motor	MCA ¹ (Amps)	Max Fuse ² / Breaker ³ Size (Amps)
		RLA	LRA	MCC	FLA	FLA		
36050, 36075	460-3-60	5.8	38.0	9.0	0.70	1.95	9.9	15
36100	460-3-60	5.8	38.0	9.0	0.70	3.15	11.1	15
48065, 48100, 48125	460-3-60	6.2	41.0	9.7	0.87	3.15	11.8	15
60065, 60100, 60125	460-3-60	7.8	52.0	12.1	0.87	3.15	13.8	20

1. Minimum Circuit Ampacity.
2. Maximum Over Current Protection per standard UL 1995.
3. Fuse or HACR circuit breaker size field installed.

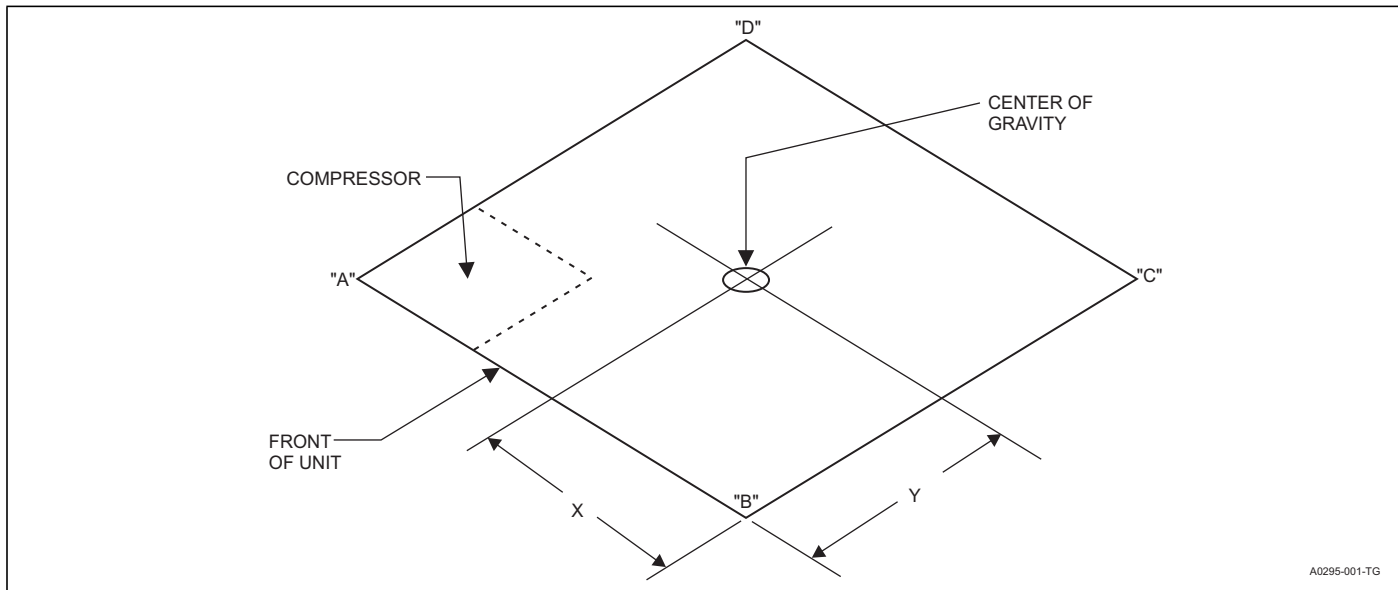

WEIGHTS AND DIMENSIONS

Model	Weight (lb)		Center of Gravity		4 Point Load Location (lb)			
	Shipping	Operating	X	Y	A	B	C	D
PCG4A360504X3	352	349	28	15	141	107	94	78
PCG4A360754X3	359	356	28	15	135	115	103	74
PCG4A361004X3	363	360	28	15	139	113	99	80
PCG4B480654X2	465	460	28	15	189	116	93	117
PCG4B481004X2	473	468	28	15	169	139	115	100
PCG4B481254X2	478	473	28	15	164	145	124	95
PCG4B600654X2	482	477	29	15	174	142	124	92
PCG4B601004X2	486	481	28	15	177	140	117	102
PCG4B601254X2	493	488	27	15	151	167	141	84

AIRFLOW PERFORMANCE - SIDE DUCT APPLICATION

Model	Motor Speed	External Static Pressure (in. W.C.)								
		0.1	0.2	0.3	0.4	0.5	0.6	0.7	0.8	1.0
		SCFM	SCFM	SCFM	SCFM	SCFM	SCFM	SCFM	SCFM	SCFM
PCG4A36050	Low (1)	1003	952	904	851	790	730	674	633	551
	Medium Low (2)	1180	1133	1085	1042	995	942	889	834	724
	Medium (3)	1259	1209	1166	1126	1084	1032	980	928	824
	Medium High (4)	1314	1271	1229	1186	1144	1097	1049	998	896
	High (5)	1506	1471	1403	1389	1345	1305	1262	1216	1124
PCG4A36075	Low (1)	1225	1174	1131	1090	1046	993	941	888	782
	Medium Low (2)	1259	1209	1166	1126	1084	1032	980	928	824
	Medium (3)	1314	1271	1229	1186	1144	1097	1049	998	896
	Medium High (4)	1348	1306	1259	1222	1179	1133	1086	1036	936
	High (5)	1506	1471	1403	1389	1345	1305	1262	1216	1124
PCG4A36100	Low (1)	1342	1302	1260	1217	1178	1134	1082	1034	938
	Medium Low (2)	1425	1368	1332	1293	1251	1208	1163	1113	1013
	Medium (3)	1554	1503	1465	1423	1386	1346	1302	1257	1167
	Medium High (4)	1658	1599	1588	1530	1495	1454	1414	1373	1291
	High (5)	1966	1914	1862	1810	1757	1705	1653	1600	1496
PCG4B48065	Low (1)	1046	1009	980	946	915	878	844	779	649
	Medium Low (2)	1295	1250	1213	1172	1133	1087	1045	964	802
	Medium (3)	1620	1564	1517	1466	1418	1360	1308	1206	1002
	Medium High (4)	1798	1722	1669	1620	1572	1527	1480	1413	1280
	High (5)	2146	2085	2025	1960	1872	1862	1798	1735	1609
PCG4B48100	Low (1)	1620	1564	1517	1466	1418	1360	1308	1206	1002
	Medium Low (2)	1694	1630	1580	1530	1482	1430	1380	1292	1116
	Medium (3)	1798	1722	1669	1620	1572	1527	1480	1413	1280
	Medium High (4)	1835	1758	1703	1653	1604	1558	1511	1442	1304
	High (5)	2146	2085	2025	1960	1872	1862	1798	1735	1609
PCG4B48125	Low (1)	1620	1564	1517	1466	1418	1360	1308	1206	1002
	Medium Low (2)	1798	1722	1669	1620	1572	1527	1480	1413	1280
	Medium (3)	1922	1863	1804	1754	1724	1658	1612	1559	1453
	Medium High (4)	2001	1952	1890	1839	1820	1742	1696	1651	1561
	High (5)	2146	2085	2025	1960	1872	1862	1798	1735	1609
PCG4B60065	Low (1)	1073	1043	1009	988	963	941	917	892	842
	Medium Low (2)	1329	1292	1250	1223	1192	1165	1136	1105	1043
	Medium (3)	2054	1998	1934	1890	1843	1801	1757	1710	1616
	Medium High (4)	2195	2144	2098	2049	2003	1955	1883	1868	1838
	High (5)	2445	2388	2306	2293	2235	2178	2129	2077	1973
PCG4B60100	Low (1)	1730	1682	1628	1592	1552	1517	1479	1439	1359
	Medium Low (2)	1858	1807	1749	1710	1667	1629	1589	1546	1460
	Medium (3)	2054	1998	1934	1890	1843	1801	1757	1710	1616
	Medium High (4)	2195	2144	2098	2049	2003	1955	1883	1868	1838
	High (5)	2445	2388	2306	2293	2235	2178	2129	2077	1973
PCG4B60125	Low (1)	2063	2008	1943	1899	1851	1809	1763	1717	1625
	Medium Low (2)	2130	2084	2032	1983	1927	1951	1860	1815	1725
	Medium (3)	2195	2144	2098	2049	2003	1955	1883	1868	1838
	Medium High (4)	2275	2252	2169	2154	2112	2065	1989	1976	1950
	High (5)	2445	2388	2306	2293	2235	2178	2129	2077	1973

1. Airflow tested with dry coil conditions, without air filters, at 460 V.

2. Applications above 0.8 in. W.C. external static pressure are not recommended.

3. Brushless DC high efficiency standard ECM blower motor used for all indoor blower assemblies.

4. Heating applications tested at 0.50 in. W.C. esp, and cooling applications tested at 0.30 in. W.C. esp per standards.

AIRFLOW PERFORMANCE - BOTTOM DUCT APPLICATION

Model	Motor Speed	External Static Pressure (in. W.C.)								
		0.1	0.2	0.3	0.4	0.5	0.6	0.7	0.8	1.0
		SCFM	SCFM	SCFM	SCFM	SCFM	SCFM	SCFM	SCFM	SCFM
PCG4A36050	Low (1)	1008	962	916	861	807	757	700	650	550
	Medium Low (2)	1190	1148	1106	1055	1008	955	914	863	761
	Medium (3)	1262	1223	1181	1137	1091	1044	994	952	868
	Medium High (4)	1324	1282	1245	1202	1161	1112	1067	1018	920
	High (5)	1517	1475	1447	1400	1357	1318	1275	1232	1146
PCG4A36075	Low (1)	1231	1186	1146	1103	1069	1030	977	912	781
	Medium Low (2)	1270	1225	1189	1140	1098	1046	1008	960	866
	Medium (3)	1317	1286	1245	1198	1151	1110	1064	1024	943
	Medium High (4)	1358	1317	1275	1238	1197	1148	1105	1057	961
	High (5)	1517	1475	1447	1400	1357	1318	1275	1232	1146
PCG4A36100	Low (1)	1340	1299	1264	1224	1182	1182	1097	1049	953
	Medium Low (2)	1409	1368	1334	1291	1253	1201	1173	1128	1038
	Medium (3)	1527	1492	1470	1419	1385	1343	1299	1250	1152
	Medium High (4)	1663	1585	1594	1601	1521	1480	1440	1400	1320
	High (5)	1930	1892	1853	1805	1760	1696	1625	1553	1409
PCG4B48065	Low (1)	1032	999	970	938	910	879	843	808	737
	Medium Low (2)	1272	1236	1204	1165	1129	1081	1037	968	829
	Medium (3)	1611	1574	1518	1494	1439	1405	1357	1266	1083
	Medium High (4)	1892	1777	1771	1701	1639	1617	1565	1489	1336
	High (5)	2131	2058	1998	1949	1892	1840	1788	1728	1608
PCG4B48100	Low (1)	1598	1548	1502	1454	1410	1362	1307	1251	1139
	Medium Low (2)	1663	1612	1568	1522	1476	1422	1370	1297	1152
	Medium (3)	1789	1733	1670	1650	1596	1578	1535	1483	1379
	Medium High (4)	1931	1814	1808	1736	1673	1650	1597	1519	1362
	High (5)	2131	2058	1998	1949	1892	1840	1788	1728	1608
PCG4B48125	Low (1)	1598	1548	1502	1454	1410	1362	1307	1251	1139
	Medium Low (2)	1766	1703	1656	1611	1566	1518	1469	1419	1319
	Medium (3)	1912	1875	1805	1787	1750	1713	1672	1636	1564
	Medium High (4)	2105	2014	2006	1931	1898	1845	1793	1739	1631
	High (5)	2131	2058	1998	1949	1892	1840	1788	1728	1608
PCG4B60065	Low (1)	1026	999	989	950	907	907	886	862	816
	Medium Low (2)	1263	1230	1192	1165	1167	1101	1099	1071	1015
	Medium (3)	1987	1933	1861	1817	1820	1715	1725	1651	1504
	Medium High (4)	2114	2050	2047	1974	1899	1889	1920	1866	1758
	High (5)	2369	2308	2249	2183	2126	2088	2034	1990	1902
PCG4B60100	Low (1)	1655	1612	1596	1531	1461	1462	1429	1391	1316
	Medium Low (2)	1766	1720	1667	1629	1632	1539	1537	1498	1421
	Medium (3)	1987	1933	1861	1817	1820	1715	1725	1651	1504
	Medium High (4)	2114	2050	2047	1974	1899	1889	1920	1866	1758
	High (5)	2369	2308	2249	2183	2126	2088	2034	1990	1902
PCG4B60125	Low (1)	1973	1924	1905	1826	1743	1744	1703	1660	1574
	Medium Low (2)	2024	1983	1937	1889	1886	1843	1799	1759	1679
	Medium (3)	2123	2075	2019	1970	1978	1862	1849	1804	1714
	Medium High (4)	2191	2154	2117	2075	2002	1995	2028	1974	1866
	High (5)	2369	2308	2249	2183	2126	2088	2034	1990	1902

1. Airflow tested with dry coil conditions, without air filters, at 460 V.
2. Applications above 0.8 in. W.C. external static pressure are not recommended.
3. Brushless DC high efficiency standard ECM blower motor used for all indoor blower assemblies.
4. Heating applications tested at 0.50 in. W.C. esp, and cooling applications tested at 0.30 in. W.C. esp per standards.

ADDITIONAL STATIC RESISTANCE

Size (Tons)	CFM	Wet Indoor Coil	Economizer ¹	Filter/Frame Kit
PCG4A36 (3.0)	700	0.01	0.00	0.04
	800	0.02	0.01	0.06
	900	0.03	0.01	0.08
	1000	0.04	0.01	0.10
	1100	0.05	0.01	0.13
	1200	0.06	0.02	0.16
	1300	0.07	0.03	0.17
PCG4B48 (4.0)	1100	0.02	0.02	0.04
	1200	0.03	0.02	0.04
	1300	0.04	0.02	0.05
	1400	0.05	0.03	0.05
	1500	0.06	0.04	0.06
	1600	0.07	0.04	0.07
	1700	0.07	0.04	0.08
	1800	0.08	0.04	0.09
PCG4B60 (5.0)	1100	0.02	0.02	0.04
	1200	0.03	0.02	0.04
	1300	0.04	0.02	0.05
	1400	0.05	0.03	0.05
	1500	0.06	0.04	0.06
	1600	0.07	0.04	0.07
	1700	0.07	0.04	0.08
	1800	0.08	0.04	0.09
1900	0.09	0.05	0.10	
2000	0.09	0.05	0.11	

1. The pressure drop through the economizer is greater for 100% outdoor air than for 100% return air. If the resistance of the return air duct is less than 0.25 IWG, the unit delivers less CFM during full economizer operation.

Note: Filter pressure drop based on standard filter media tested at velocities not to exceed 300 ft/min.

BOTTOM DUCT DIMENSIONS (in.)

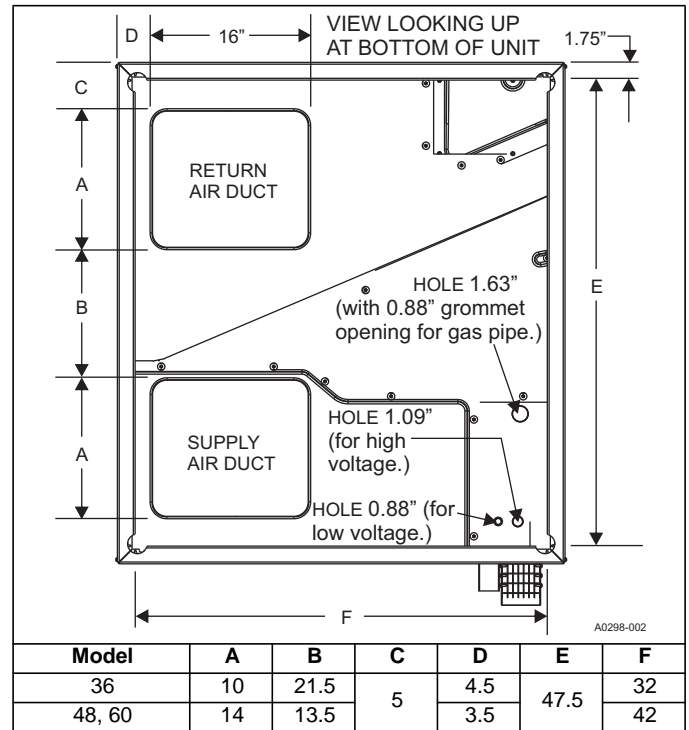

REAR DUCT DIMENSIONS (in.)

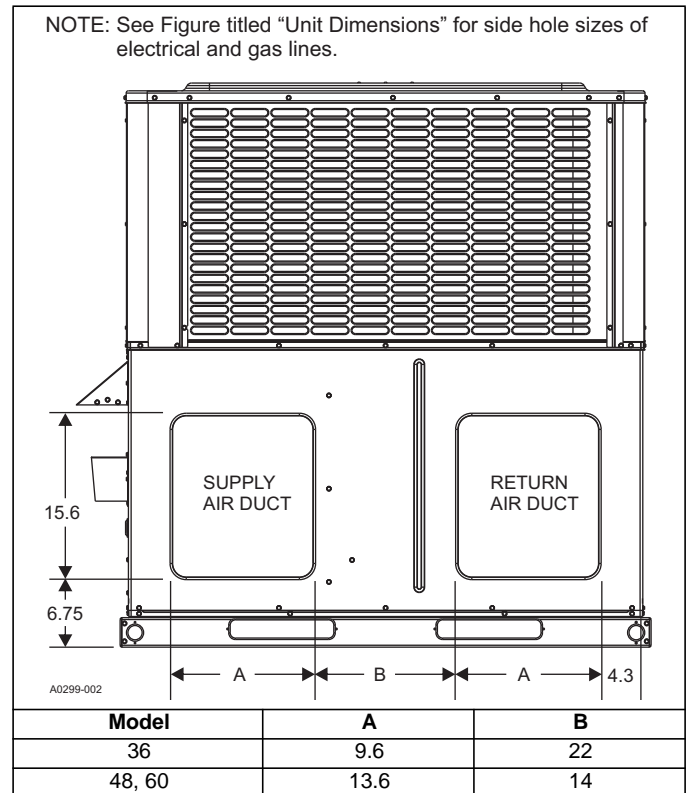

UNIT TYPICAL DUCT APPLICATIONS

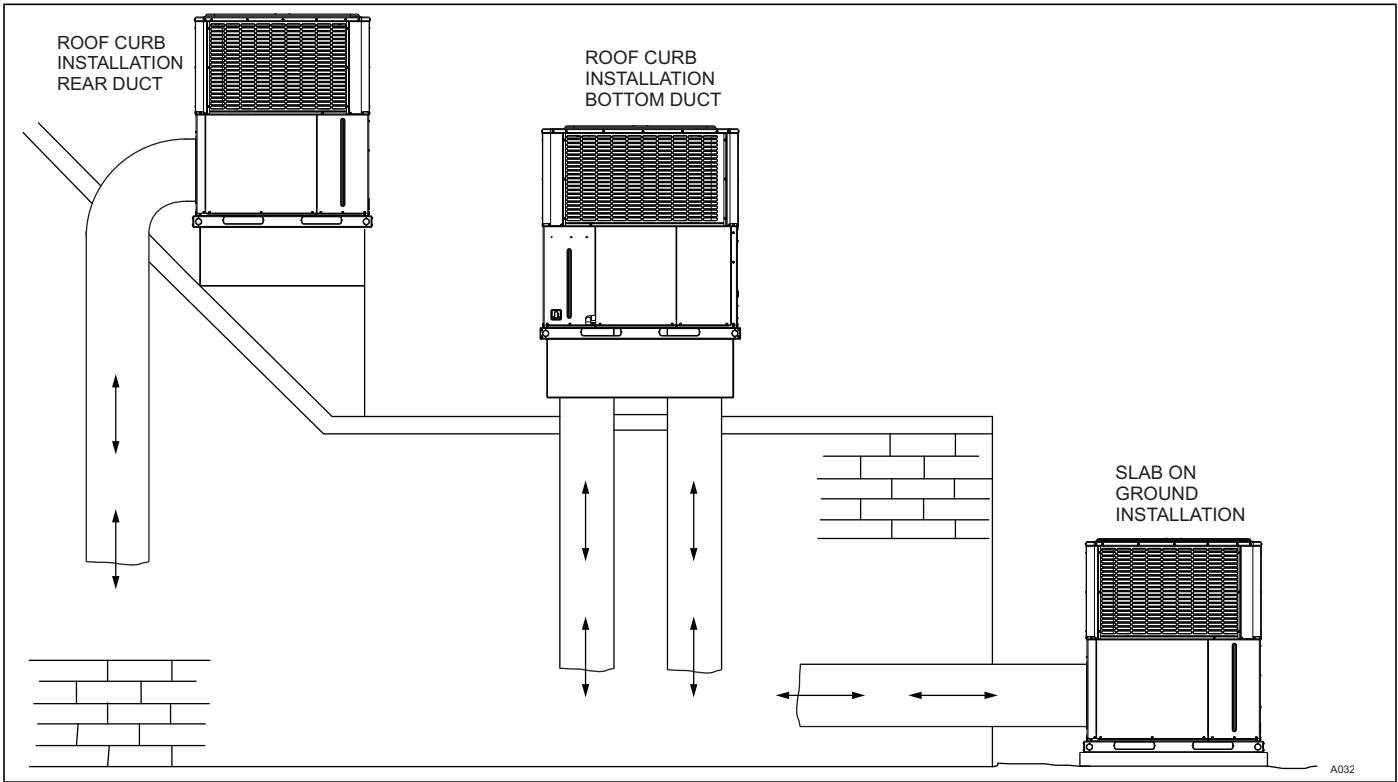

UNIT TYPICAL SLAB ON GROUND INSTALLATION

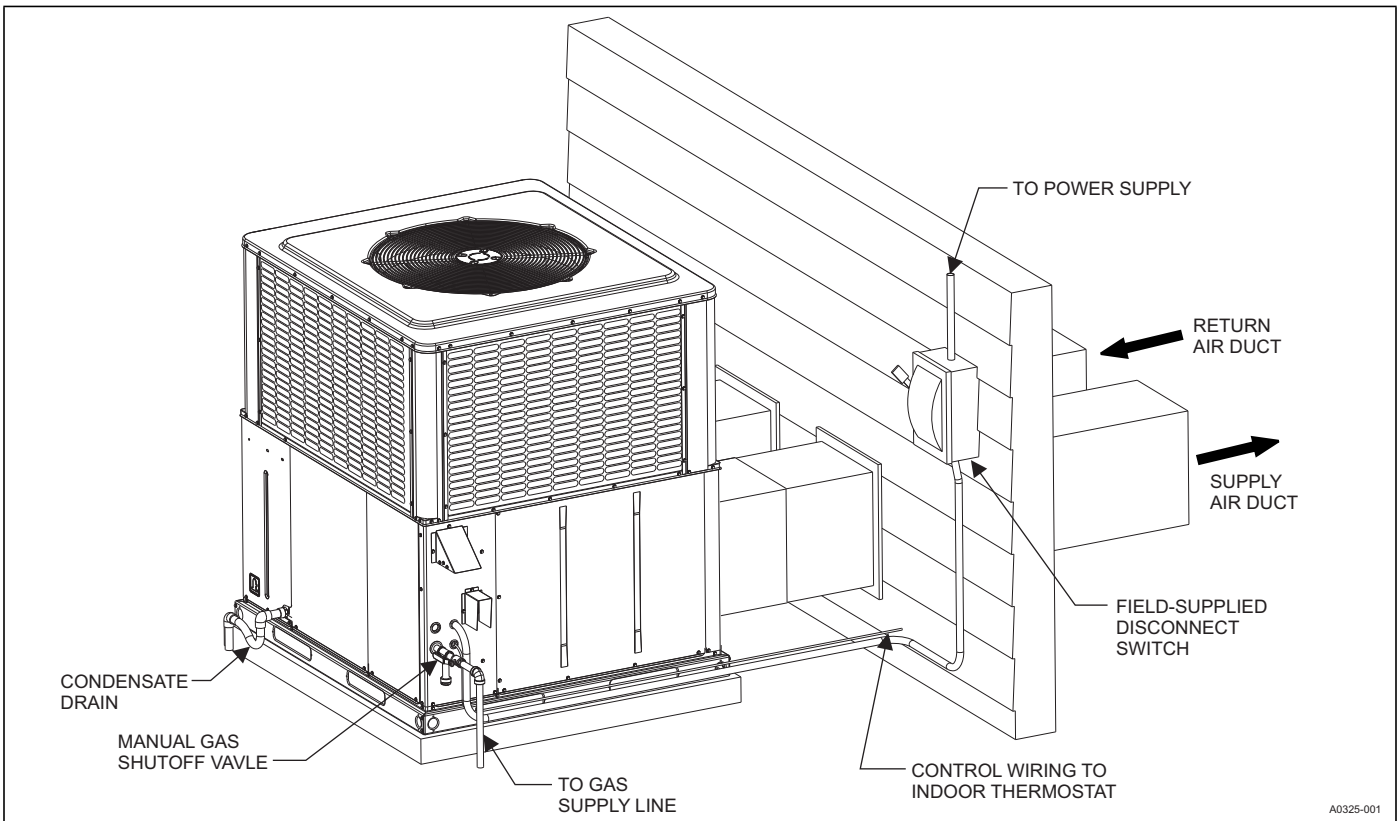

UNIT TYPICAL ROOF CURB INSTALLATION

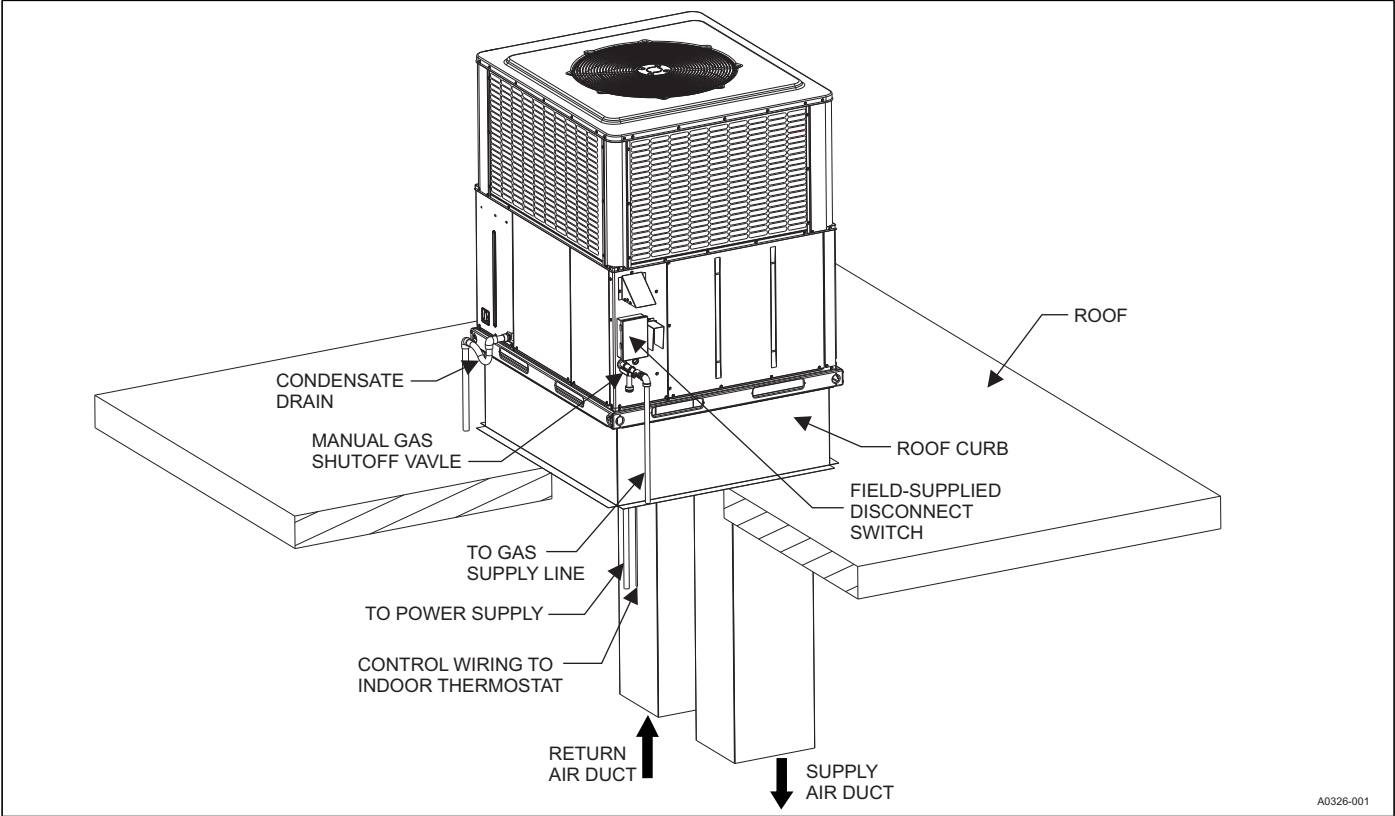

NOTES