

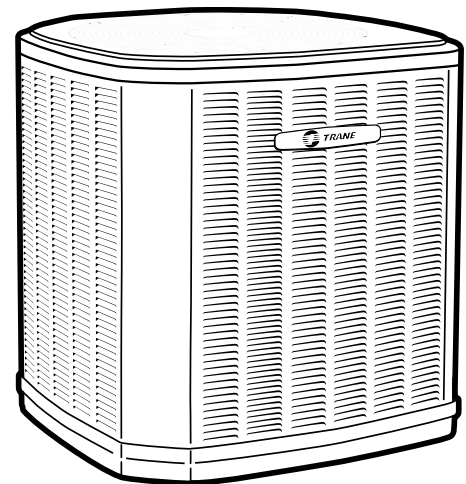

Product Data

Split System Air Conditioner 3-Phase

4TTA7036A3000A
4TTA7048A3000A
4TTA7060A3000A
4TTA7036A4000A
4TTA7048A4000A
4TTA7060A4000A



Note: "Graphics in this document are for representation only. Actual model may differ in appearance."



Table of Contents

Product Specifications	3
Sound Power Level	5
Accessory Description and Usage	6
Model Nomenclature.....	6
SCHEMATIC	7
Outline Drawing	9
Mechanical Specification Options.....	10



Product Specifications

Model No. ^{(a) (b)}	4TTA7036A3000A	4TTA7048A3000A	4TTA7060A3000A
POWER CONNS. — V/PH/HZ ^(c)	230/3/60	230/3/60	230/3/60
MIN. BRCH. CIR. AMPACITY	15	18	22
BR. CIR. PROT. RTG. — MAX. (AMPS)	25	30	35
COMPRESSOR	CLIMATUFF®- SCROLL	CLIMATUFF®- SCROLL	CLIMATUFF®- SCROLL
R.L. AMPS ^(d) — L.R. AMPS	11.6 — 73	14 — 83	16.2 — 110
Outdoor Fan FL AMPS	0.74	0.93	1.30
Fan HP	1/8	1/5	1/4
Fan Dia (inches)	27.6	27.6	27.6
Coil	SPINE FIN™	SPINE FIN™	SPINE FIN™
Refrigerant R-410A ^(e)	9 LBS., 13 OZ	11 LBS., 15 OZ	12 LBS., 9 OZ
LINE SIZE — IN. O.D. GAS ^{(f) (g)}	3/4	7/8	1 1/8
LINE SIZE — IN. O.D. LIQ. ^(h)	3/8	3/8	3/8
Charge Spec. Subcooling	9°F	8°F	8°F
Dimensions H x W X D Crated (IN.)	51.0 x 38.7 x 35.1	51.0 x 38.7 x 35.1	51.0 x 38.7 x 35.1
Weight — Shipping (lbs.)	283	285	308
Weight — Net (lbs.)	245	248	271
Optional Accessories:			
Anti-short Cycle Timer	TAYASCT501A	TAYASCT501A	TAYASCT501A
Evaporator Defrost Control	NA	NA	NA
Rubber Isolator Kit	BAYISLT101	BAYISLT101	BAYISLT101
Extreme Condition Mount Kit	BAYECMT023	BAYECMT004	BAYECMT004
Crankcase Heater Kit	—	—	—
Seacoast Kit	BAYSEAC001	BAYSEAC001	BAYSEAC001
Low Ambient Kit	BAYLOAM107	BAYLOAM107	BAYLOAM107
Refrigerant Lineset ⁽ⁱ⁾	TAYREFLN7*	TAYREFLN3*	TAYREFLN3*
Sound Enclosure	BAYSDEN003	BAYSDEN004	BAYSDEN004
Snow Legs — 6"	BAYLEGS002	BAYLEGS002	BAYLEGS002
Snow Legs Extension — 4"	BAYLEGS003	BAYLEGS003	BAYLEGS003
Service Valve Panel Cover	TAYSVPANL3343AA	TAYSVPANL0044AA	TAYSVPANL0044AA

(a) Certified in accordance with the Air-Source Unitary Air-conditioner Equipment certification program, which is based on AHRI standard 210/240.

(b) Rated in accordance with AHRI standard 270.

(c) Calculated in accordance with N.E.C. Only use HACR circuit breakers or fuses.

(d) This value shown for compressor RLA on the unit nameplate and on this specification sheet is used to compute minimum branch circuit ampacity and max. fuse size. The value shown is the branch circuit selection current.

(e) This value approximate. For more precise value see unit nameplate.

(f) Reference the outdoor unit ship-with literature for refrigerant piping length and lift guidelines. Reference the refrigerant piping software pub # 32-3312-xx or refrigerant piping application guide SS-APG006-xx for long line sets or specialty applications (xx denotes latest revision).

(g) Trane outdoor condensing units are factory charged with the system charge required for the outdoor condensing unit and 15 feet of tested connecting lines. If connecting line length exceeds 15 feet, then final refrigerant charge adjustment is necessary. Each additional foot over 15 feet requires 0.6 ozs of refrigerant. See the Installer's Guide for full charging instructions.

(h) This value approximate. For more precise value see unit nameplate.

(i) * = 15, 20, 25, 30, 40 and 50 foot lineset available.



Product Specifications

Model No. ^{(a) (b)}	4TTA7036A4000A	4TTA7048A4000A	4TTA7060A4000A
POWER CONNS. — V/PH/Hz ^(c)	460/3/60	460/3/60	460/3/60
MIN. BRCH. CIR. AMPACITY	8	9	10
BR. CIR. PROT. RTG. — MAX. (AMPS)	15	15	15
COMPRESSOR	CLIMATUFF®- SCROLL	CLIMATUFF®- SCROLL	CLIMATUFF®- SCROLL
R.L. AMPS ^(d) — L.R. AMPS	5.7 — 38	6.4 — 41	7.6 — 52
Outdoor Fan FL AMPS	0.40	0.60	0.72
Fan HP	1/8	1/5	1/4
Fan Dia (inches)	27.6	27.6	27.6
Coil	SPINE FIN™	SPINE FIN™	SPINE FIN™
Refrigerant R-410A ^(e)	9 LBS., 13 OZ	11 LBS., 15 OZ	12 LBS., 9 OZ
LINE SIZE — IN. O.D. GAS ^{(f) (g)}	3/4	7/8	1 1/8
LINE SIZE — IN. O.D. LIQ. ^(h)	3/8	3/8	3/8
Charge Spec. Subcooling	9°F	8°F	8°F
Dimensions H x W X D Crated (IN.)	51.0 x 38.7 x 35.1	51.0 x 38.7 x 35.1	51.0 x 38.7 x 35.1
Weight — Shipping (lbs.)	283	285	308
Weight — Net (lbs.)	245	248	271
Optional Accessories:			
Anti-short Cycle Timer	TAYASCT501A	TAYASCT501A	TAYASCT501A
Evaporator Defrost Control	NA	NA	NA
Rubber Isolator Kit	BAYISLT101	BAYISLT101	BAYISLT101
Extreme Condition Mount Kit	BAYECMT023	BAYECMT004	BAYECMT004
Crankcase Heater Kit	—	—	—
Seacoast Kit	BAYSEAC001	BAYSEAC001	BAYSEAC001
Low Ambient Kit	BAYLOAM107	BAYLOAM107	BAYLOAM107
Refrigerant Lineset ⁽ⁱ⁾	TAYREFLN7*	TAYREFLN3*	TAYREFLN3*
Sound Enclosure	BAYSDEN003	BAYSDEN004	BAYSDEN004
Snow Legs — 6"	BAYLEGS002	BAYLEGS002	BAYLEGS002
Snow Legs Extension — 4"	BAYLEGS003	BAYLEGS003	BAYLEGS003
Service Valve Panel Cover	TAYSVPANL3343AA	TAYSVPANL0044AA	TAYSVPANL0044AA

^(a) Certified in accordance with the Air-Source Unitary Air-conditioner Equipment certification program, which is based on AHRI standard 210/240.

^(b) Rated in accordance with AHRI standard 270.

^(c) Calculated in accordance with N.E.C. Only use HACR circuit breakers or fuses.

^(d) This value shown for compressor RLA on the unit nameplate and on this specification sheet is used to compute minimum branch circuit ampacity and max. fuse size. The value shown is the branch circuit selection current.

^(e) This value approximate. For more precise value see unit nameplate.

^(f) Reference the outdoor unit ship-with literature for refrigerant piping length and lift guidelines. Reference the refrigerant piping software pub # 32-3312-xx or refrigerant piping application guide SS-APG006-xx for long line sets or specialty applications (xx denotes latest revision).

^(g) Trane outdoor condensing units are factory charged with the system charge required for the outdoor condensing unit and 15 feet of tested connecting lines. If connecting line length exceeds 15 feet, then final refrigerant charge adjustment is necessary. Each additional foot over 15 feet requires 0.6 ozs of refrigerant. See the Installer's Guide for full charging instructions.

^(h) This value approximate. For more precise value see unit nameplate.

⁽ⁱ⁾ * = 15, 20, 25, 30, 40 and 50 foot lineset available.



Sound Power Level

Sound Power Level

MODEL	A-Weighted Sound Power Level [dB(A)]	Full Octave Sound Power(dB)							
		63 Hz	125 Hz	250 Hz	500 Hz	1000 Hz	2000 Hz	4000 Hz	8000 Hz
4TTA7036A	72	74	71	72	70	69	62	59	55
4TTA7048A	73	85	74	68	69	69	63	58	54
4TTA7060A	74	75	71	71	71	70	65	58	52



Accessory Description and Usage

Anti-Short Cycle Timer — Solid state timing device that prevents compressor recycling until five (5) minutes have elapsed after satisfying call or power interruptions. Use in area with questionable power delivery, commercial applications, long lineset, etc.

Evaporation Defrost Control — SPST Temperature actuated switch that cycles the condenser off as indoor coil reaches freeze-up conditions. Used for low ambient cooling to 30°F with TXV.

Rubber Isolators — Five (5) large rubber donuts to isolate condensing unit from transmitting energy into mounting frame or pad. Use on any application where sound transmission needs to be minimized.

Hard Start Kit — Start capacitor and relay to assist compressor motor startup. Use in areas with marginal power supply, on long linesets, low ambient conditions, etc.

Extreme Condition Mount Kit — Bracket kits to securely mount condensing unit to a frame or pad without removing any panels. Use in areas with high winds, or on commercial roof tops, etc.

AHRI Standard Capacity Rating Conditions

AHRI Standard 210/240 Rating Conditions

1. Cooling 80°F DB, 67°F WB air entering indoor coil, 95°F DB air entering outdoor coil.
2. High Temperature Heating 47°F DB, 43°F WB air entering outdoor coil, 70°F DB air entering indoor coil.
3. Low Temperature Heating 17°F DB air entering indoor coil.
4. Rated indoor airflow for heating is the same as for cooling.

AHRI Standard 270 Rating Conditions — (Noise rating numbers are determined with the unit in cooling operations.) Standard Noise Rating number is at 95°F outdoor air.

Model Nomenclature

Outdoor Units

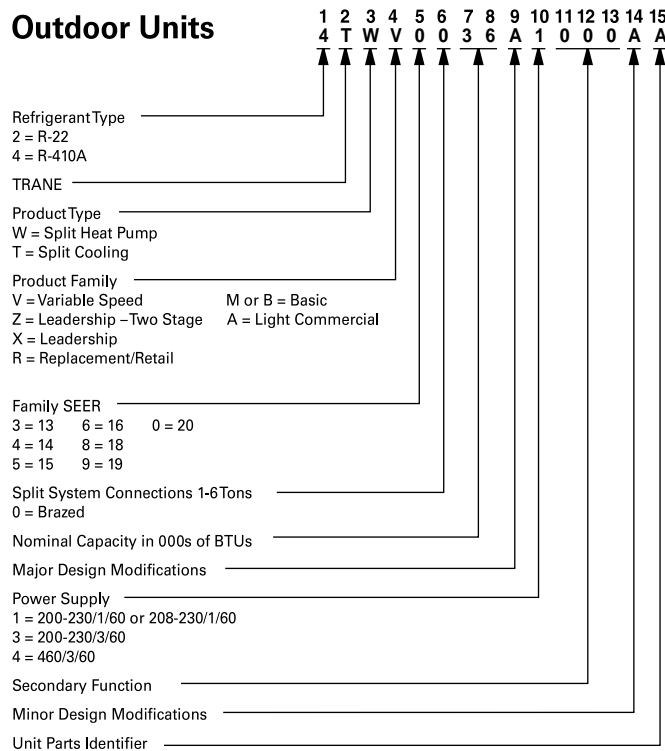



SCHEMATIC

230V AC — D159205P02

TO POWER SUPPLY PER UNIT NAMEPLATE AND LOCAL CODES

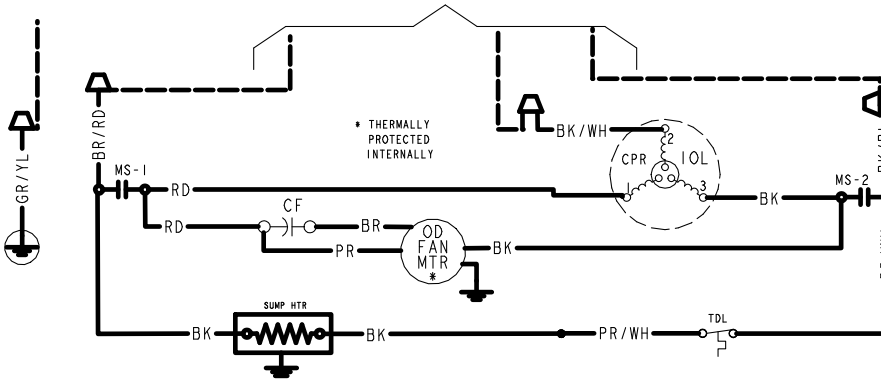

COLOR OF WIRE
BK/BL ←
COLOR OF MARKER
BK BLACK RD RED OR ORANGE
BL BLUE WH WHITE GR GREEN
BR BROWN YL YELLOW PR PURPLE
PK PINK

- ACR A/C RECTIFIER
- CBS COIL BOTTOM SENSOR
- CF FAN CAPACITOR
- CN WIRE CONNECTOR
- CPR COMPRESSOR
- CR RUN CAPACITOR
- CS STARTING CAPACITOR
- CSR CAPACITOR SWITCHING RELAY
- F INDOOR FAN RELAY
- HPCO HIGH PRESSURE CUTOFF SWITCH
- IOL INTERNAL OVERLOAD PROTECTOR
- LPCO LOW PRESSURE CUTOFF SWITCH
- MS COMPRESSOR MOTOR CONTACTOR
- ODA OUTDOOR ANTICIPATOR
- ODF OUTDOOR FAN RELAY
- OFT OUTDOOR FAN THERMOSTAT
- ODS OUTDOOR TEMPERATURE SENSOR
- ODT OUTDOOR THERMOSTAT
- SC SWITCH OVER VALVE SOLENOID
- SHR SUMP HEAT RELAY
- SM SYSTEM ON-OFF SWITCH
- TDL DISCHARGE LINE THERMOSTAT
- TNS TRANSFORMER
- TEMP SENSOR, TEMPERATURE

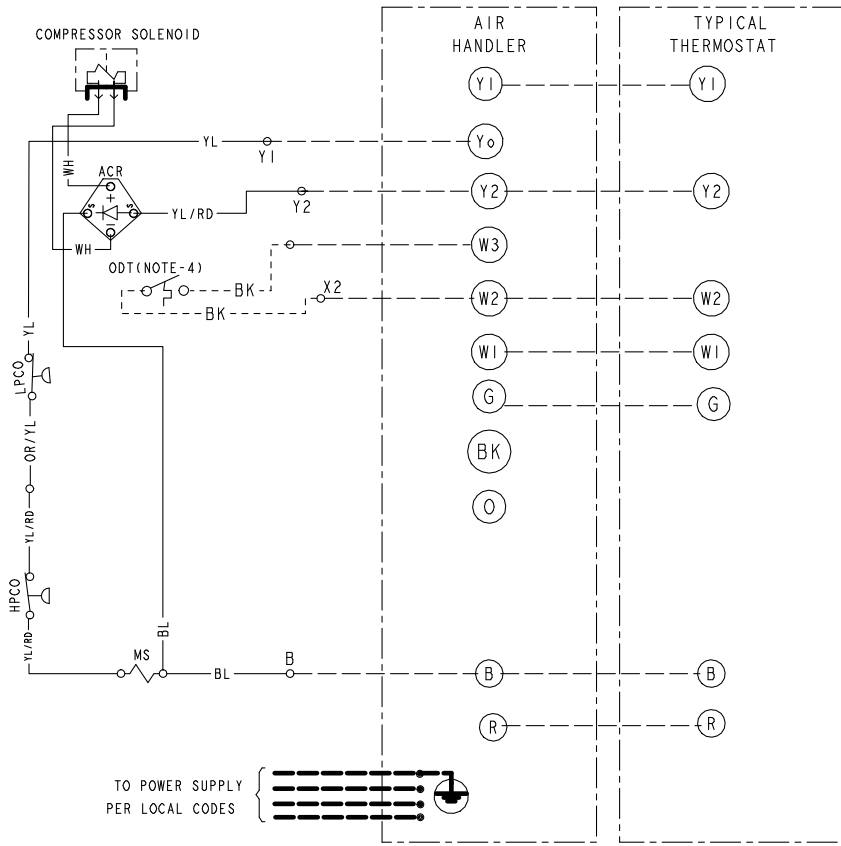

⚠ WARNING

HAZARDOUS VOLTAGE!
DISCONNECT ALL ELECTRICAL POWER INCLUDING REMOTE DISCONNECTS BEFORE SERVICING.
Failure to disconnect power before servicing can cause severe personal injury or death.

⚠ CAUTION

USE COPPER CONDUCTORS ONLY!
UNIT TERMINALS ARE NOT DESIGNED TO ACCEPT OTHER TYPES OF CONDUCTORS.
Failure to do so may cause damage to the equipment.

- NOTES:
1. BE SURE POWER SUPPLY AGREES WITH EQUIPMENT NAMEPLATE.
 2. POWER WIRING AND GROUNDING OF EQUIPMENT MUST COMPLY WITH LOCAL CODES.
 3. LOW VOLTAGE WIRING MUST BE 18 AWG MINIMUM CONDUCTOR.
 4. IF OUTDOOR THERMOSTAT IS NOT USED, CONNECT W2 TO W3 AT AIR HANDLER.
 5. WITH Y1 ENERGIZED, INDOOR FAN IS 1ST STAGE AIRFLOW.
 6. WITH Y1 & Y2 ENERGIZED, INDOOR FAN IS 2ND STAGE AIRFLOW.
 7. SEE AIR HANDLER INSTALLER GUIDE FOR DIP SWITCH CONFIGURATIONS.

460V AC — D159376P01

TO POWER SUPPLY PER UNIT NAMEPLATE AND LOCAL CODES

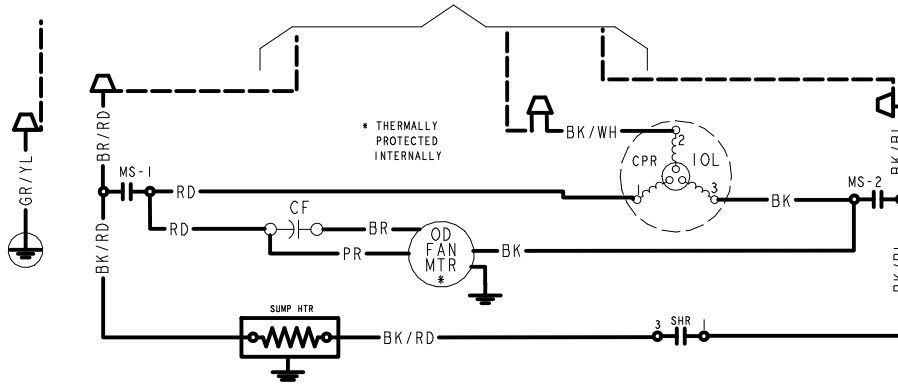

COLOR OF WIRE
BK/BL
COLOR OF MARKER

BK BLACK RD RED OR ORANGE
BL BLUE WH WHITE GR GREEN
BR BROWN YL YELLOW PR PURPLE
PK PINK

- ACR A/C RECTIFIER
- CBS COIL BOTTOM SENSOR
- CF FAN CAPACITOR
- CN WIRE CONNECTOR
- CPR COMPRESSOR
- CR RUN CAPACITOR
- CS STARTING CAPACITOR
- CSR CAPACITOR SWITCHING RELAY
- F INDOOR FAN RELAY
- HPCO HIGH PRESSURE CUTOFF SWITCH
- IOL INTERNAL OVERLOAD PROTECTOR
- LPCO LOW PRESSURE CUTOFF SWITCH
- MS COMPRESSOR MOTOR CONTACTOR
- ODA OUTDOOR ANTICIPATOR
- ODF OUTDOOR FAN RELAY
- OFT OUTDOOR FAN THERMOSTAT
- ODS OUTDOOR TEMPERATURE SENSOR
- ODT OUTDOOR THERMOSTAT
- SC SWITCH OVER VALVE SOLENOID
- SHR SUMP HEAT RELAY
- SM SYSTEM ON-OFF SWITCH
- TDL DISCHARGE LINE THERMOSTAT
- TNS TRANSFORMER
- TEMP SENSOR, TEMPERATURE

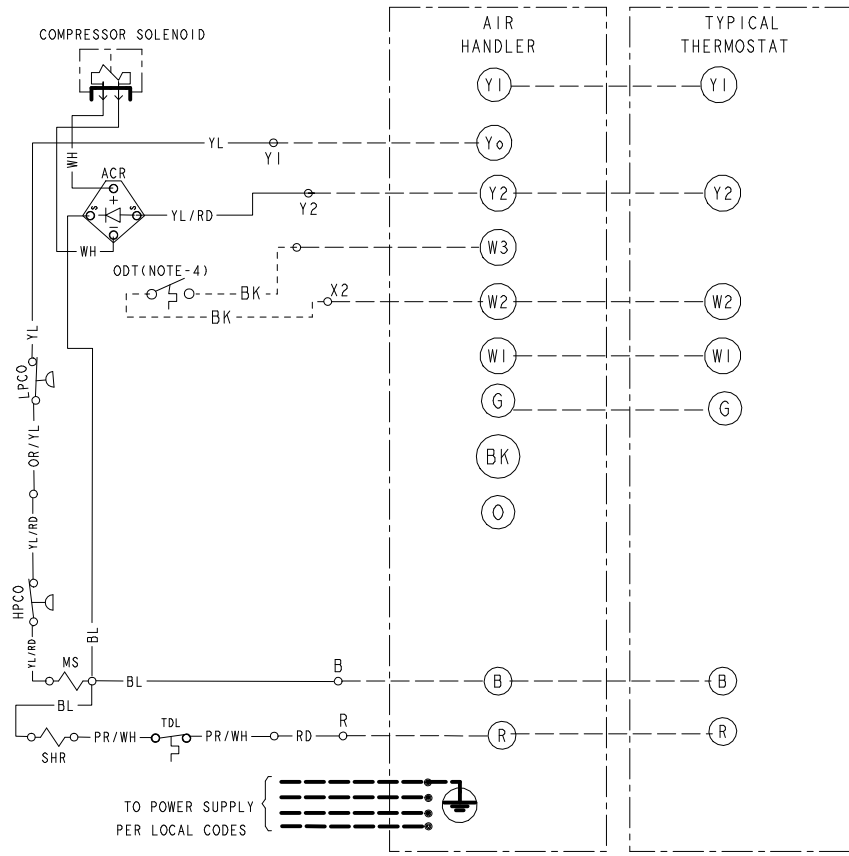

WARNING
HAZARDOUS VOLTAGE!
DISCONNECT ALL ELECTRICAL POWER INCLUDING REMOTE DISCONNECTS BEFORE SERVICING.
Failure to disconnect power before servicing can cause severe personal injury or death.

CAUTION
USE COPPER CONDUCTORS ONLY!
UNIT TERMINALS ARE NOT DESIGNED TO ACCEPT OTHER TYPES OF CONDUCTORS.
Failure to do so may cause damage to the equipment.

- NOTES:
1. BE SURE POWER SUPPLY AGREES WITH EQUIPMENT NAMEPLATE.
 2. POWER WIRING AND GROUNDING OF EQUIPMENT MUST COMPLY WITH LOCAL CODES.
 3. LOW VOLTAGE WIRING MUST BE 18 AWG MINIMUM CONDUCTOR.
 4. IF OUTDOOR THERMOSTAT IS NOT USED, CONNECT W2 TO W3 AT AIR HANDLER.
 5. WITH Y1 ENERGIZED, INDOOR FAN IS 1ST STAGE AIRFLOW.
 6. WITH Y1 & Y2 ENERGIZED, INDOOR FAN IS 2ND STAGE AIRFLOW.
 7. SEE AIR HANDLER INSTALLER GUIDE FOR DIP SWITCH CONFIGURATIONS.



Outline Drawing

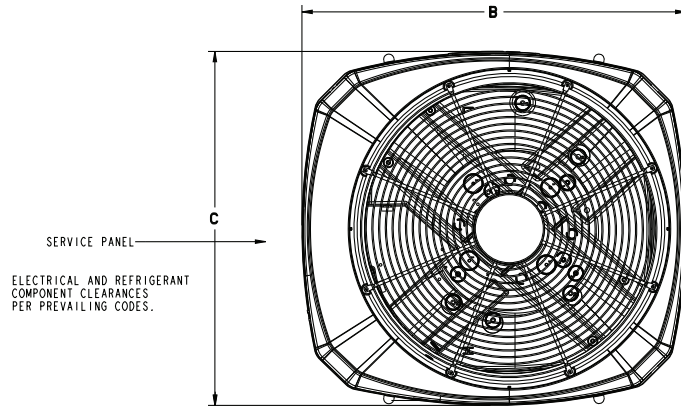

TOP DISCHARGE AREA SHOULD BE UNRESTRICTED FOR AT LEAST 1524 (5 FEET) ABOVE UNIT. UNIT SHOULD BE PLACED SO ROOF RUN-OFF WATER DOES NOT POUR DIRECTLY ON UNIT, AND SHOULD BE AT LEAST 305 (12") FROM WALL AND ALL SURROUNDING SHRUBBERY ON TWO SIDES. OTHER TWO SIDES UNRESTRICTED.

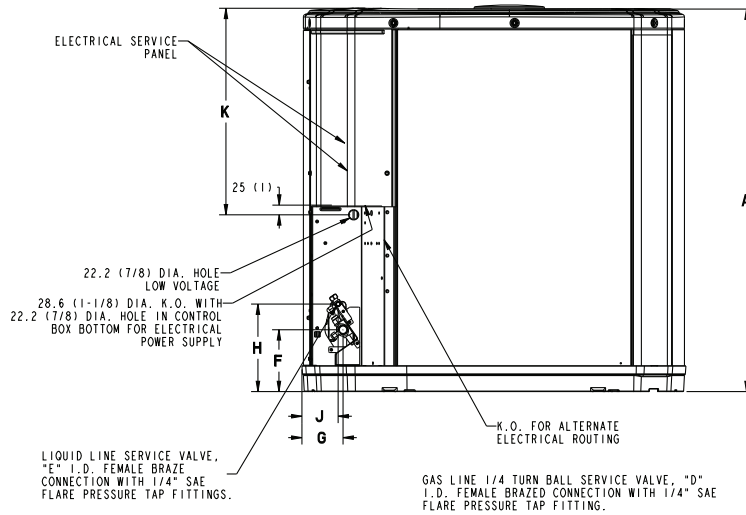

Model	Base	A	B	C	D	E	F	G	H	J	K
4TTA7036A	4	1147 (45-1/8)	946 (37-1/4)	870 (34-1/4)	3/4	3/8	152 (6)	98 (3-7/8)	219 (8-5/8)	86 (3-3/8)	813 (32)
4TTA7048A	4	1147 (45-1/8)	946 (37-1/4)	870 (34-1/4)	7/8	3/8	152 (6)	98 (3-7/8)	219 (8-5/8)	86 (3-3/8)	813 (32)
4TTA7060A	4	1147 (45-1/8)	946 (37-1/4)	870 (34-1/4)	1-1/8	3/8	152 (6)	98 (3-7/8)	219 (8-5/8)	86 (3-3/8)	813 (32)



Mechanical Specification Options

General

The Outdoor Units are fully charged from the factory for up to 15 feet of piping. This unit is designed to operate at outdoor ambient temperatures as high as 115°F. Cooling capacities are matched with a wide selection of air handlers and furnace coils that are AHRI certified. The unit is certified to UL 1995. Exterior is designed for outdoor application.

Casing

Unit casing is constructed of heavy gauge, galvanized steel and painted with a weather-resistant powder paint finish on all louvered panels and the fan top panel. The corner panels are prepainted. All panels are subjected to our 1,000 hour salt spray test. The base is made of a CMBP-G30 weatherproof material to resist corrosion.

Refrigerant Controls

Refrigeration system controls include condenser fan, compressor contactor and high pressure switch. High and low pressure controls are inherent to the compressor. A factory supplied liquid line drier is standard. Some models may require field installation.

Compressor

The compressor features internal over temperature, pressure protection and total dipped hermetic motor. Other features include: Centrifugal oil pump and low vibration and noise.

Condenser Coil

The outdoor coil provides low airflow resistance and efficient heat transfer. The coil is protected on all four sides by louvered panels.

Low Ambient Cooling

As manufactured, this system has a cooling capacity to 55°F. The addition of an evaporator defrost control permits operation to 40°F. The addition of an evaporator defrost control with TXV permits low ambient cooling to 30°F.

Thermostats—Cooling only and heat/cooling (manual and automatic change over). Sub-base to match thermostat and locking thermostat cover.

Evaporator Defrost Control — See Low Ambient Cooling.



Trane optimizes the performance of homes and buildings around the world. A business of Ingersoll Rand, the leader in creating and sustaining safe, comfortable and energy efficient environments, Trane offers a broad portfolio of advanced controls and HVAC systems, comprehensive building services, and parts. For more information, visit www.Trane.com.

Trane has a policy of continuous product and product data improvements and reserves the right to change design and specifications without notice.

©2016 Trane
22-1924-1A-EN 17 May 2016
Supersedes (New)

