



## Compact Seal Splice

### 1. SCOPE

#### 1.1. Content

This specification covers performance, tests, and quality requirements for “Compact Seal Splice” with part number 2378100-X, applied according application specification 114-106569.

#### 1.2. Qualification

When tests are performed on the subject product line, procedures specified in Table 1 shall be used. All inspections shall be performed using the applicable inspection plan and product drawing.

#### 1.3. Qualification Test Results

Successful qualification testing on the subject product line was completed in . The Qualification Test Report number for this testing is 501-106569 .

#### 1.4. Revision Summary

Revisions to this specification include:

- Initial release of specification.

### 2. APPLICABLE DOCUMENTS AND FORMS

The following documents form a part of this specification to the extent specified herein. Unless otherwise specified, the latest edition of the document applies. In the event of conflict between the requirements of this specification and the product drawing, the product drawing shall take precedence. In the event of conflict between the requirements of this specification and the referenced documents, this specification shall take precedence.

#### 2.1. TE Connectivity Specifications

|            |                           |
|------------|---------------------------|
| 114-106569 | Application Specification |
| 501-106569 | Qualification Test Report |

#### 2.2. Commercial Standards and Specifications

|           |  |
|-----------|--|
| IEC 61984 | International Standard – Safety Requirements and Tests   |
| IEC 60335 | International Standard – Safety of Household and Similar Appliance                               |
| IEC 60512 | International Standard – Connectors for Electronic Equipment – Tests and Measurements            |
| IEC 60695 | International Standard – Fire Hazard Testing   |
| UL 1977   | Safety Standards – Component Connectors for Use in Data, Signal, Control, and Power Applications |
| EIA-364   | Electrical Connector/Socket Test Procedures Including Environmental Classifications              |

#### 2.3. Reference Documents

|                         |   |
|-------------------------|---|
| <a href="#">109-1</a>   | General Requirements for Testing                |
| <a href="#">102-950</a> | Qualification of Separable Interface Connectors |

### 3. REQUIREMENTS

#### 3.1. Design and Construction

Product shall be of the design, construction, materials and physical dimensions specified on the applicable product drawing.

3.2. Materials

Materials used in the construction of this product shall be as specified on the applicable TE drawing.

- A. Housing: Polycarbonate (UL94 V-0, UL746C F1)
- B. Contacts: CuNiSi

3.3. Ratings

| Part number | Voltage       | Certified Wire                               | Current   | Temperature  | IP rating |
|-------------|---------------|--|---|--|-----------|
| 2378100-X   | 600 V AC / DC | UL1015,<br>IEC 60245<br>57(YZW) <sup>1</sup> | 12 AWG: 20 A Max.<br>14 AWG: 15 A Max.<br>16 AWG: 10 A Max.<br>18 AWG: 7 A Max.<br>2.5mm <sup>2</sup> : 20A Max.<br>1.5mm <sup>2</sup> : 15A Max.<br>1.0mm <sup>2</sup> : 10A Max.<br>0.75mm <sup>2</sup> : 6A Max. | -40 °C to +105 °C.<br>Ambient<br>temperature Max<br>75 °C. | IPX7      |

<sup>1</sup> Remove the Jacket before use

| Part number | Wire Range                        | Insulation diameter    |
|-------------|-----------------------------------|------------------------|
| 2378100-1   | 14-12AWG, 2.5 mm <sup>2</sup>     | 3.4~4.1mm <sup>2</sup> |
| 2378100-2   | 16-14AWG, 1.5mm <sup>2</sup>      | 3.0~3.6mm <sup>2</sup> |
| 2378100-3   | 18-16AWG, 0.75-1.5mm <sup>2</sup> | 2.3~3.2mm <sup>2</sup> |

3.4. Performance Requirements and Test Description

The product should meet the electrical, mechanical and environmental performance requirements specified in Table 1. All tests shall be performed at ambient environmental conditions otherwise specified.

3.5. Test Requirements and Procedure Summary

| Test Description               | Requirement   | Procedure  |
|--------------------------------|---|--|
| Initial examination of product | Meets requirements of product drawing.  | Visual, dimensional and functional inspection, according to the Quality Inspection Plan. |
| Visual Examination of Product  | The product shall not have visible marks of damage, break, or defect before and after the execution of the tests. | EIA-364-18B  |

**Electrical**

| Contact resistance   | Initial resistance maximum 20 mΩ<br>Final resistance maximum 100 mΩ  | EIA-364-23, Option 1<br>Open voltage:<br>20 mV maximum<br>Current 100 mA maximum   |                |                 |                     |     |                     |       |                     |       |                      |     |
|--|--|--|----------------|-----------------|---------------------|-----|---------------------|-------|---------------------|-------|----------------------|-----|
| Insolation resistance  | 500 MΩ minimum   | IEC 60512-3-1 Test 3a  |                |                 |                     |     |                     |       |                     |       |                      |     |
| Wet leakage current test   | 400 MΩ minimum   | IEC 61215-2-2012<br>600V ac , Duration: 120 s  |                |                 |                     |     |                     |       |                     |       |                      |     |
| Temperature rise   | ΔT < 30°C  | EIA 364-70, Method 1<br><br>Test Current ref. 3.3  |                |                 |                     |     |                     |       |                     |       |                      |     |
| Voltage proof (between adjacent contacts and contacts & housing) | No abnormalities, such as breakdown and flashover, shall occur,  | IEC 60512-4-1 Test 4A<br>3400 V ac Duration: 60 s  |                |                 |                     |     |                     |       |                     |       |                      |     |
| Current Cycling (UL Wire)  | Number of cycles: 500<br>Current: 1hour on and 1 hour off.<br>Temperature rise:<br>1. Without any connector exceeding 125°C<br>2. The stability factor "Si" shall not exceed ± 10 for connector temperature measurements taken at approximately 25, 50, 75, 100, 125, 175, 225, 275, 350, 425, and 500 cycles.<br><br>$S_i = d_i - D$<br>$D = [(d_1 + d_2 + \dots + d_{11}) / 11]$ | UL486C, Item 7.2<br>Suitable for sample testing with UL wire installed<br><table border="1"> <thead> <tr> <th>Conductor Size</th> <th>Current Cycling</th> </tr> </thead> <tbody> <tr> <td>12AWG</td> <td>39A</td> </tr> <tr> <td>14AWG</td> <td>33A</td> </tr> <tr> <td>16AWG</td> <td>20A</td> </tr> <tr> <td>18AWG</td> <td>19A</td> </tr> </tbody> </table>                                      | Conductor Size | Current Cycling | 12AWG               | 39A | 14AWG               | 33A   | 16AWG               | 20A   | 18AWG                | 19A |
| Conductor Size   | Current Cycling  |  |                |                 |                     |     |                     |       |                     |       |                      |     |
| 12AWG  | 39A  |  |                |                 |                     |     |                     |       |                     |       |                      |     |
| 14AWG  | 33A  |  |                |                 |                     |     |                     |       |                     |       |                      |     |
| 16AWG  | 20A  |  |                |                 |                     |     |                     |       |                     |       |                      |     |
| 18AWG  | 19A  |  |                |                 |                     |     |                     |       |                     |       |                      |     |
| Current Cycling (IEC Wire)                                       | Number of cycles:192<br>Current: 1hour on and 1 hour off.<br>Temperature rise:<br>1. ΔT ≤ 45°C<br>2. The maximum allowable voltage drop of each clamping unit, measured with the current .<br>Either 22.5 mV or 1,5 times the value measured after the 24 cycle.   | Suitable for sample testing with IEC wire installed<br><table border="1"> <thead> <tr> <th>Conductor Size</th> <th>Current Cycling</th> </tr> </thead> <tbody> <tr> <td>2.5 mm<sup>2</sup></td> <td>24A</td> </tr> <tr> <td>1.5 mm<sup>2</sup></td> <td>17.5A</td> </tr> <tr> <td>1.0 mm<sup>2</sup></td> <td>13.5A</td> </tr> <tr> <td>0.75 mm<sup>2</sup></td> <td>9A</td> </tr> </tbody> </table> | Conductor Size | Current Cycling | 2.5 mm <sup>2</sup> | 24A | 1.5 mm <sup>2</sup> | 17.5A | 1.0 mm <sup>2</sup> | 13.5A | 0.75 mm <sup>2</sup> | 9A  |
| Conductor Size   | Current Cycling  |  |                |                 |                     |     |                     |       |                     |       |                      |     |
| 2.5 mm <sup>2</sup>  | 24A  |  |                |                 |                     |     |                     |       |                     |       |                      |     |
| 1.5 mm <sup>2</sup>  | 17.5A  |  |                |                 |                     |     |                     |       |                     |       |                      |     |
| 1.0 mm <sup>2</sup>  | 13.5A  |  |                |                 |                     |     |                     |       |                     |       |                      |     |
| 0.75 mm <sup>2</sup>   | 9A   |  |                |                 |                     |     |                     |       |                     |       |                      |     |

**Mechanical**

|                               |   |   |
|-------------------------------|---|---|
| Cable retention force (axial) | 12 AWG 155 N , 14 AWG 111 N ,<br>16 AWG 66.7 N, 18 AWG 44.5 N | The AWG wire refer to UL 486C, Item 7.4.2<br>The IEC wire refer to IEC 60998-2-3, Item 10.107.2 |
|-------------------------------|---|---|

|                             |  |   |          |  |
|-----------------------------|--|---|----------|--|
|                             | 2.5 mm <sup>2</sup> 50 N, 1.5 mm <sup>2</sup> 40 N<br>1.0 mm <sup>2</sup> 35 N, 0.75 mm <sup>2</sup> 30 N<br>During the test the conductor shall not slip out of the sepcimens   | Apply minimum force, Hold 1 minute and remove force.<br>(See Figure 1)  |          |  |
| Cable retention force (90°) | 12 AWG 155 N, 14 AWG 111 N, 16 AWG 66.7 N, 18 AWG 44.5 N<br>2.5 mm <sup>2</sup> 50 N, 1.5 mm <sup>2</sup> 40 N<br>1.0 mm <sup>2</sup> 35 N, 0.75 mm <sup>2</sup> 30 N<br>During the test the conductor shall not slip out of the sepcimens | Cable pulled 90° on insertion direction (towards the button).<br>(See Figure 1)<br>Apply minimum force, Hold 1 minute and remove force.   |          |  |
| Vibration Test              | No visual damage.<br>Discontinuity <1 µsec<br>Final resistance maximum 100 mΩ  | IEC 60068-2-6<br>Duration: 4 hours for each axis (x, y, z).<br>Frequency: 10-200-10 Hz<br>Peak to peak amplitude 1,0 mm<br>Speed: 1 octave/min.<br>Acceleration: 5 g (See Figure 3)   |          |  |
| Secureness Test             | Wire Size  | Height(mm)  | Mass(Kg) | UL 486C, Item 9.3.2<br>Test lasts 30 minutes<br>Rate: 9 Rpm. |
|                             | 12 AWG   | 279   | 2.3      |  |
|                             | 14 AWG / 2.5 mm <sup>2</sup>   | 279   | 1.4      |  |
|                             | 16 AWG / 1.5mm <sup>2</sup> /1.0 mm <sup>2</sup>   | 260   | 0.9      |  |
|                             | 18 AWG / 0.75 mm <sup>2</sup>  | 260   | 0.9      |  |
| Torsion                     | No visual damage.<br>Maximum resistance after testing not exceeding 100 mΩ.<br>Pass sealing test   | Each extending cable shall in turn be clamped rigidly at a distance of 100 mm, measured from the sepcimen base. The Compact seal splice shall be axially rotated through 90° and retained in that position for a period of 5 minutes. No tensile load shall be applied. It shall then be returned to its original position and the procedure repeated in the opposite direction. (See Figure 4)<br>Number of cycles:5   |          |  |
| Flexure                     | No visual damage.<br>Maximum resistance after testing not exceeding 100 mΩ.<br>Pass sealing test   | The Compact seal splice shall be clamped on a smooth, flat, horizontal surface. Each cable shall be clamped in turn at 100 mm from the end of the closure base. Cables shall be bent individually to an angle of 30° each side of neutral in the same plane. Each bending operation shall be held for 5 min. It shall then be returned to its original position and the procedure repeated in the opposite direction. The procedure shall be repeated with each cable protruding from the closure system (See Figure 5)<br>Number of cycles:5 |          |  |
| Impact Test                 | No damage which could impair normal usage.<br>Maximum resistance after testing not exceeding 100 mΩ.   | IEC 60512-7-2<br>Subject sepcimens to a single fall from a height of 1.5M onto an uncoated concrete floor 3 times. One side of the sepcimen is wired, and the other side is wired after the impact test is completed.   |          |  |

|                  |                 |   |
|------------------|-----------------|---|
| Separation force | Minimum of 50 N | Pulling two mated Compact seal splice apart by means of pulling from wires. (See Figure 2)<br>Choose 14-12AWG wire for testing<br>Speed: 100mm/mins |
|------------------|-----------------|---|

**Environmental**

|               |   |  |
|---------------|---|--|
| IPX5          | Protected against water immersion   | IEC 60529<br>Jetting water   |
| IPx7          | Protected against water immersion   | IEC 60529<br>30 minutes submerged in 1 meter depth   |
| Cold          | No visual damage.<br>Final resistance maximum 100 mΩ<br>Insulation resistance: 500 MΩ minimum<br>Withstand voltage: 3400 V ac, 60 s | IEC 60068-2-1<br>Temperature: -40 °C<br>Duration: 2h   |
| Dry heat      | No visual damage.<br>Final resistance maximum 100 mΩ<br>Insulation resistance: 500 MΩ minimum<br>Withstand voltage: 3400 V ac, 60 s | IEC 60068-2-2<br>Temperature: 105 °C<br>Duration: 2h   |
| Damp heat     | No visual damage.<br>Final resistance maximum 100 mΩ<br>Insulation resistance: 500 MΩ minimum<br>Withstand voltage: 3400 V ac, 60 s | IEC 60068-2-3<br>Temperature: 85 ± 2 °C<br>Relative humidity: 85 ± 2 %<br>Duration: 96h  |
| Thermal shock | No visual damage.<br>Final resistance maximum 100 mΩ<br>Insulation resistance: 500 MΩ minimum<br>Withstand voltage: 3400 V ac, 60 s | IEC 60068-2-14, Test Na<br><br>T <sub>a</sub> = -40 °C; T <sub>b</sub> = 105 °C<br>100 cycles, 30 min/30 min<br>Temperature transition: no more than 3min. |

**Table 1**



**NOTE**

*Shall meet visual requirements, show no physical damage, and meet requirements of additional tests as specified in the Product Qualification and Requalification Test Sequence shown in Table .*

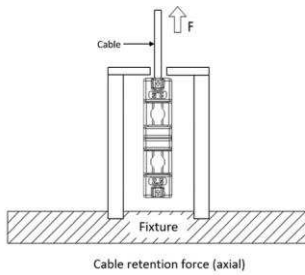

**Figure 1 Cable retention force**

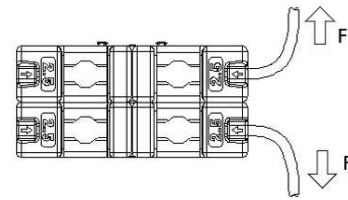
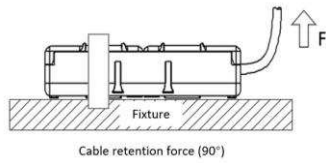

**Figure 2 Separation force**

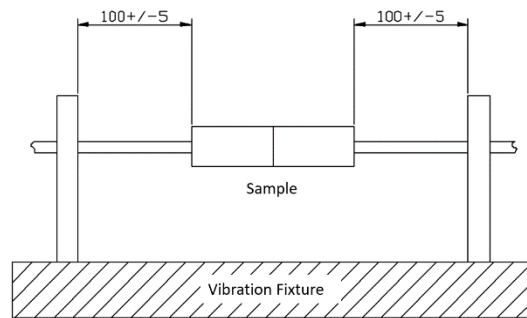

**Figure 3 Vibration Test**

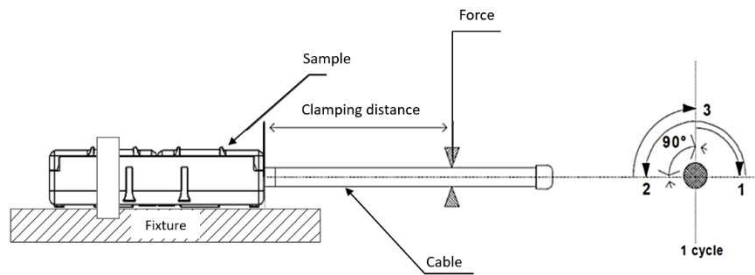

**Figure 1 Torsion**

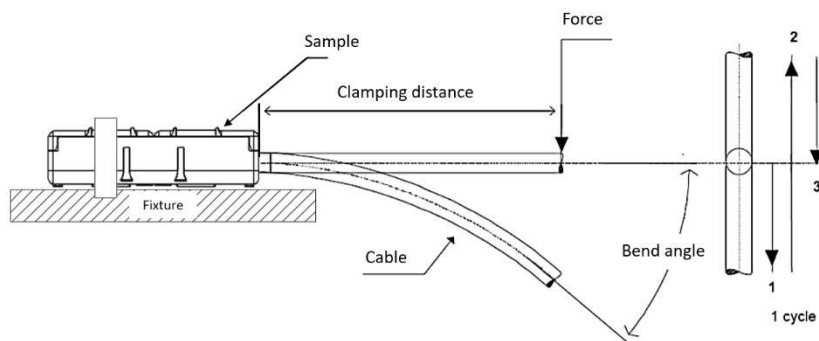

**Figure 2 Flexure**

3.6. Product Qualification and Requalification Test Sequence

| TEST OR EXAMINATION                      | TEST GROUP (a)    |                |      |       |         |      |      |      |
|--|-------------------|----------------|------|-------|---------|------|------|------|
|  | A                 | B              | C    | D     | E       | F_1  | F_2  | G    |
|  | TEST SEQUENCE (b) |                |      |       |         |      |      |      |
| Visual examination of product            | 1, 14             | 1, 18          | 1, 5 | 1,4,7 | 1, 14   | 1, 8 | 1, 8 | 1, 8 |
| Contact resistance                       | 2,7,11            | 2, 6, 8, 10,12 | 3    | 3,6   | 2, 6,10 | 2, 5 | 2, 5 |      |
| Insulation resistance                    |                   | 13             |      |       | 12      |      |      |      |
| Wet leakage current test                 | 3,5,9, 13         | 3, 17          |      |       | 3,8     | 3,7  | 3,7  | 2, 7 |
| Temperature rise                         |                   | 5, 15          |      |       | 11      |      |      | 3, 5 |
| Voltage Proof                            | 10                | 4, 14          |      |       | 13      |      |      |      |
| Current Cycling(UL Wire)                 |                   |                |      |       |         | 4    |      |      |
| Current Cycling(IEC Wire)                |                   |                |      |       |         |      | 4    |      |
| Cable retention force (axial)            |                   |                |      | 2     |         |      |      |      |
| Cable retention force (90°) - Other Side |                   |                |      | 5     |         |      |      |      |
| Vibration Test                           | 6                 |                |      |       |         |      |      |      |
| Secureness Test                          |                   |                |      |       |         |      |      | 4    |
| Torsion                                  |                   |                |      |       | 4       |      |      |      |
| Flexure                                  |                   |                |      |       | 5       |      |      |      |
| Impact Test                              |                   |                | 2    |       |         |      |      |      |
| Separation force                         |                   |                | 4    |       |         |      |      |      |
| IPX5                                     | 4, 8              |                |      |       |         |      |      |      |
| IPX7                                     | 12                | 16             |      |       | 7       | 6    | 6    | 6    |
| Cold                                     |                   | 7              |      |       |         |      |      |      |
| Dry heat                                 |                   | 9              |      |       |         |      |      |      |
| Damp heat                                |                   | 11             |      |       |         |      |      |      |
| Thermal shock                            |                   |                |      |       | 9       |      |      |      |

Table 2



**NOTE**

(a) See paragraph 4.2.

(b) Numbers indicate sequence in which tests are performed.

**4. QUALITY ASSURANCE PROVISIONS**

4.1. Test Conditions

Unless otherwise specified, all the tests shall be performed in any combination of the following test conditions shown in Table .

|                      |                  |
|----------------------|------------------|
| Temperature          | 15°C – 35°C      |
| Relative Humidity    | 45% – 75%        |
| Atmospheric Pressure | 86.6 – 106.6 kPa |

**Table 3**

#### 4.2. Qualification Testing

##### A. Specimen Selection

Specimens shall be prepared in accordance with applicable instruction sheets and shall be selected at random from current production.

##### B. Test Sequence

Qualification inspection shall be verified by testing specimens as specified in Table 3.

#### 4.3. Requalification Testing

If changes significantly affecting form, fit or function are made to the product or manufacturing process, product assurance shall coordinate requalification testing, consisting of all or part of the original testing sequence as determined by development/product, quality and reliability engineering.

#### 4.4. Acceptance

Acceptance is based on verification that the product meets the requirements in Table 1. Failures attributed to equipment, test setup or operator deficiencies shall not disqualify the product. If product failure occurs, corrective action shall be taken and specimens resubmitted for qualification. Testing to confirm corrective action is required before resubmittal.

#### 4.5. Quality Conformance Inspection

The applicable quality inspection plan shall specify the sampling acceptable quality level to be used. Dimensional and functional requirements shall be in accordance with the applicable product drawing and this specification.