

SAMSUNG

SINGLE

Technical

Data Book

Max Heat Line up for America
(R410A, HP)



Model : CNH**4DB (AC***BN4DCH/AA), CNH**HDB (AC***BNHDCH/AA), CNH**ZDB(AC***BNZDCH/AA)
CXH**SCB (AC***BXSCCH/AA)

History

Version	Modification	Date	Remark
Ver.1.0	Released 2022 CAC Max Heat Line up for North America	22. 12. 09	

Features & Benefits

CAC - World-class energy efficiency

Maintain optimal comfort and control with energy and cost-efficient technologies

Featuring a suite of energy-optimizing technologies, Samsung CAC Single delivers top-class energy efficiency to support business in saving costs and the environment.

Quick, efficient heating and cooling

Smart inverter technology offers powerful, quick cooling and heating with minimal electricity consumption, which means real cost savings and less energy waste.

Up to 50 percent less energy use

After reaching changes its operation mode to economical. By avoiding inefficient and frequent switching on and off of the compressor, the digital inverter saves up to 50 percent in energy consumption compared to non-inverter air conditioners.

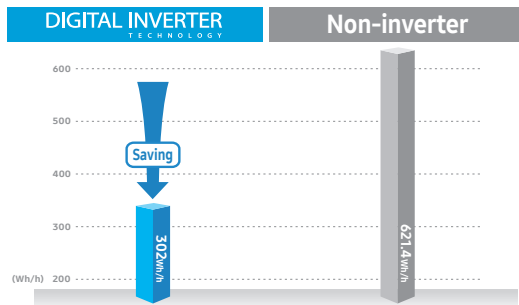

Wind-Free Cooling with Micro holes

- The Wind-Free Air conditioner pushes air out through 15,000 micro holes in the panel, producing a dispersed and gentle flow of air actually defined as “still air” and the key here is all of those holes create a still, cooled air flow that infiltrates the room gently and softly.
- ※ Still Air condition : According to ASHRAE, If velocity of wind is lower than 0.15m/s, People can not detect wind. And they define that condition is “Still Air”

No Direct Wind & Cold Draft

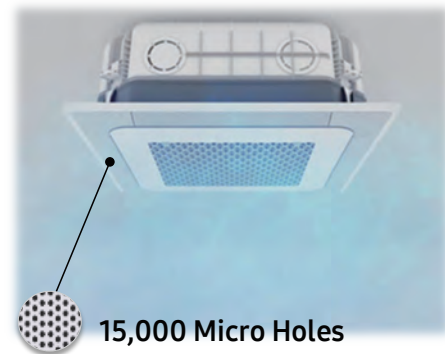

※ Wind-Free 4Way(600x600) : 9,000 Micro Holes

[Comparison of Room Temp.]

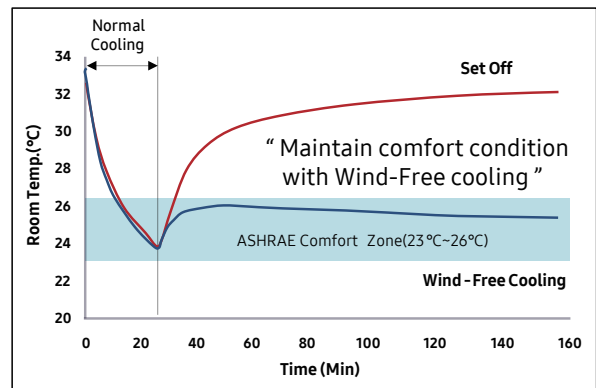

※ Internal Test (14.0kW Model @ 122m²)

Features & Benefits

CAC Single - Superior performance

Stabilize the atmosphere with broad temperature allowance and control

Samsung is dedicated to supporting comfortable living and working environments based on the strength of its technologies. With a single unit, CAC Single delivers reliable comfort and control over multiple areas to ensure a pleasant atmosphere in any climate.

Wide temperature performance

No matter how extreme the temperature, the high-performing CAC Single can handle the condition- without the need for an additional unit. Featuring a wide temperature allowance, it can cool in heat of up to 50 and provide warmth in the freezing cold of -20°C to ensure a constant and comfortable home environment.

Ideal comfort in minutes

The CAC Single digital inverter air conditioner works at maximum capacity at startup. As soon as the temperature reaches the desired or set temperature, CAC Single performs fine adjustments to cope with any changes. This means less temperature fluctuation and ideal comfort in a matter of minutes.

Various selection of Discharging

Flexible installation by simply adjusting discharging direction

- Top & Left Side Discharge : Basic direction placing the product vertically or horizontally
- Right Side Discharge : By simply changing location of condensate drain pan to the right, installers can place the product with right side discharge
- Bottom Discharge : With easy application of down-flow kit, installers can flip over the product and adjust discharging direction to bottom

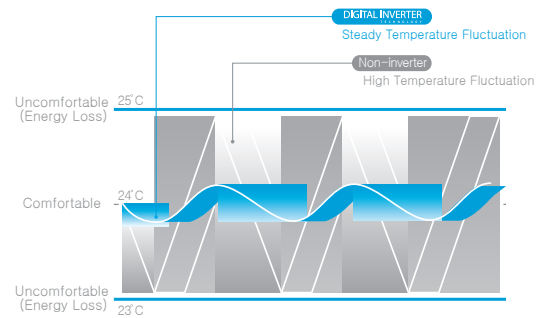

Versatile piping installation

CAC Single outdoor units offer a selection of pipe directions. The internal pipe connection ports allow four different pipe directions, supporting a neater, more organized-looking unit upon installation.

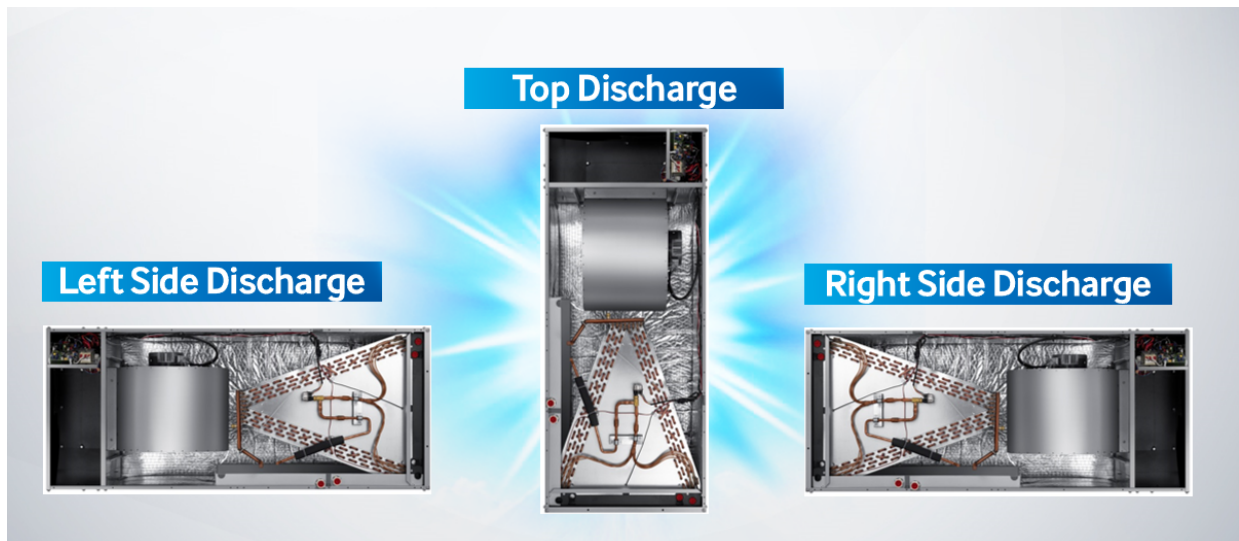

Nomenclature

US Code

Model Name

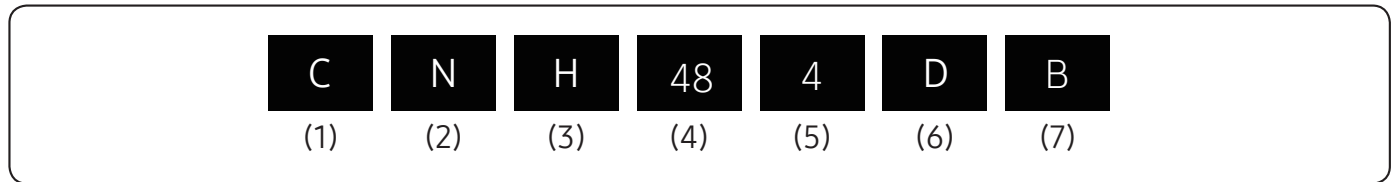

(1) Classification

C	CAC
---	-----

(2) Product Type

N	Indoor Unit
X	Outdoor Unit

(3) Mode

A	Universal
C	Cooling Only
H	Heat Pump

(4) Capacity

	X1,000 Btu/h (2 digits)
--	-------------------------

(5-1) Product Notation (Indoor Unit)

1	1 Way Cassette / Wind-Free 1Way Cassette
N	4 Way Cassette (600x600) Wind-Free 4 Way Cassette (600x600)
4	4 Way Cassette, 360 Cassette Wind-Free 4 Way Cassette
L	LSP Duct
H	HSP Duct
C	Ceiling
J	Console
A	AR9500 (Wall Mounted)
T	MAX4 (Wall Mounted)
Z	Multi-position AHU

(5-2) Feature1 (Outdoor Unit)

A	Inv+Side+General Temp
S	Inv+Side+Low Temp
Q	Inv+Side+Tropical Temp
F	Inv+Top+Tropical Temp

(6) Feature

F	Flagship
S	Standard
D	Deluxe
P	Premium
C	Deluxe + Low Temp.

(7) Version

B	2022
K	2016

Nomenclature

Indoor Unit

Model Name



(1) Classification

AC	CAC
----	-----

(2) Capacity

X1,000 Btu/h (3 digits)

(3) Version

B	2022
K	2016

(4) Product Type

N	Indoor Unit
X	Outdoor Unit

(5) Product Notation

1	1 Way Cassette
N	4 Way Cassette (600x600) Wind-Free 4 Way Cassette (600x600)
4	4 Way Cassette, 360 Cassette Wind-Free 4 Way Cassette
L	LSP Duct
H	HSP Duct
C	Ceiling
J	Console
A	AR9500 (Wall Mounted)
T	MAX4 (Wall Mounted)
Z	Multi-position AHU

(6) Feature

F	Flagship
S	Standard
D	Deluxe
P	Premium

(7) Rating Voltage

C	1Φ, 208-230V,60Hz
---	-------------------

(8) Mode

C	Cooling Only
H	Heat Pump

Nomenclature

Outdoor Unit

Model Name

AC	048	B	X	A	D	C	H	/	AA
(1)	(2)	(3)	(4)	(5)	(6)	(7)	(8)		Buyer

(1) Classification

AC	CAC
----	-----

(2) Capacity

x 1000 Btu/h (3 digits)

(3) Version

B	2022
---	------

(4) Product Type

N	Indoor Unit (NASA)
X	Outdoor Unit (NASA)

(5) Feature1

A	Inv+Side+General Temp
S	Inv+Side+Low Temp
Q	Inv+Side+Tropical Temp
F	Inv+Top+Tropical Temp

(6) Feature2

F	Flagship
S	Standard
D	Deluxe
P	Premium
C	Deluxe + Low Temp.

(7) Rating Voltage







C	1Φ, 208~230V, 60Hz
H	3Φ, 400V, 60Hz

(8) Mode

H	Heat Pump(R410A)
C	Cooling Only(R410A)
E	Heat Pump(R22)
D	Cooling Only(R22)

Line-up

Indoor unit

Model	Capacity (kBtu/h)	
	30	36
Wind-Free 4Way Cassette		
Duct S		
Multi-position AHU		

Outdoor Unit

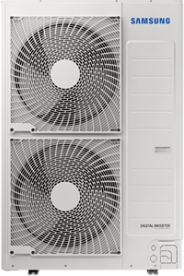
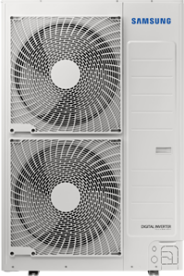
Model	Capacity (kBtu/h)	
	30	36
CXH**SCB (AC**BXSCCH/AA)		

Contents

Wind-Free 4Way Cassette	10
Duct S	23
Multi-position AHU	40
Outdoor Units	51
Installation	62

Wind-Free 4Way Cassette

1. Specification	12
2. Summary Table	14
3. Capacity Table	15
4. Dimensional Drawing	17
5. Center of Gravity	18
6. Electrical Wiring Diagram	19
7. Sound Data	20
8. Temperature and air flow distribution	22

Features & Benefits

Wind-Free 4Way Cassette

Stage a beautiful yet comfortable environment

With its newly improved design, Wind-Free 4Way Cassette supports a clean, aesthetically appealing atmosphere and adds a sense of sophistication to work and living spaces. Not only is this unit attractively designed, but it also uses advanced technologies to optimize comfort in any environment.

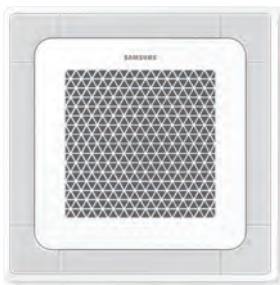

Wind-Free 4Way Cassette - Stylishly clean design

Aesthetic panel and display

Wind-Free 4Way Cassette offers two different pattern designs for the panel. The simple display design with rounded corners adds a chic sophistication to the interior.



The Samsung Wind-Free 4Way Cassette indoor air conditioning system delivers polish, comfort and efficiency with features such as:

- **Stylishly clean design.** Add panache to interior spaces with a choice of clean, streamlined panel patterns in a lightweight build.
- **Robust operation.** Control the atmosphere perfectly with an advanced design for superior airflow and cooling/heating performance.
- **Low maintenance and simple installation.** Ease installation and minimize maintenance with a detachable, no-drip design.

Neat and clean design

The indoor Wind-Free 4Way Cassette boasts a smart design that promotes a neat and clean look. The completely hermetic blade structure keeps the indoor unit clean by preventing dust or other foreign substances from entering it. The internal parts of the indoor unit are also out of sight when the blade is shut, thus improving the unit's appearance.

Lightweight build

The Samsung Wind-Free 4Way Cassette indoor unit is now lighter in weight at 17 kg. It is one of the lightest indoor units in the industry, about 40 percent lighter than conventional products.

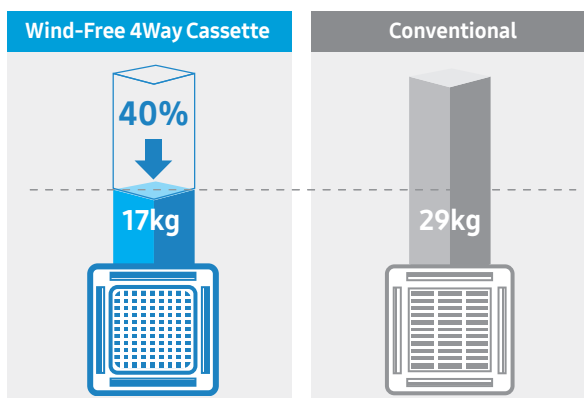

*Based on 10kW

1. Specification

Wind-Free 4Way Cassette

Model Name		Indoor Unit		AC030BN4DCH/AA		AC036BN4DCH/AA		
US Code		Indoor Unit		CNH304DB		CNH364DB		
		Outdoor Unit		CXH30SCB		CXH36SCB		
System	Mode			-	Heat Pump	Heat Pump		
	Performance	Capacity (Min/Std/Max)	Cooling	kW	3.81/8.79/10.55	4.10/10.55/12.31		
				Btu/h	13,000 / 30,000 / 36,000	14,000 / 36,000 / 42,000		
				US RT	1.08/2.50/3.00	1.17/3.00/3.50		
			Heating	kW	2.93/9.96/11.72	3.08/11.72/13.19		
				Btu/h	10,000 / 34,000 / 40,000	10,500 / 40,000 / 45,000		
				US RT	0.83/2.83/3.33	0.88/3.33/3.75		
	Power	Power Input (Min/Std/Max)	Cooling	kW	0.80 / 2.27 / 3.20	0.85 / 2.77 / 3.90		
			Heating	kW	0.53 / 2.59 / 4.50	0.55 / 3.05 / 4.80		
		Current Input (Min/Std/Max)	Cooling	A	4.2 / 10.3 / 14.3	4.5 / 12.5 / 17.1		
			Heating	A	2.8 / 11.9 / 19.8	2.9 / 13.8 / 21.1		
		Current	MCA	A	32.1	33.2		
			MOP	A	40	40		
	Efficiency	EER2	Cooling	-	3.87	3.81		
			Cooling(US)	(Btu/h)/W	13.2	13.0		
		COP2	Heating	W/W	3.85	3.85		
		SEER2		-	22.6	21.6		
		HSPF2		-	8.9	9.1		
	Pipe Connections	Liquid Pipe	Type		Flare	Flare		
			Φ, mm(inch)		9.52 (3/8)	9.52 (3/8)		
		Gas Pipe	Type		Flare	Flare		
			Φ, mm(inch)		15.88 (5/8)	15.88 (5/8)		
		Heat Insulation		-	Both liquid and gas pipes	Both liquid and gas pipes		
		Pipe Length (ODU-IDU)	Standard	Max.	m (ft)	7.5 (24.6)	7.5 (24.6)	
				Elevation	m (ft)	30 (98.4)	30 (98.4)	
	Chargeless			m (ft)	7.5 (24.6)	7.5 (24.6)		
				m (ft)	7.5 (24.6)	7.5 (24.6)		
	Wiring Connections	Communication	Min.	mm ²	0.75	0.75		
Remark			-	F1,F2	F1,F2			
Refrigerant	Type		-	R410A	R410A			
	Factory Charging		kg	4.0	4.0			
			lbs	8.82	8.82			
Option Code	Standard		-	0143FF-195418-275A5E-370040	0143FF-19546A-276975-370040			
	Install		-	020010-100001-200000-300000	020010-100001-200000-300000			
Indoor Unit	Power Supply			Φ,#,V,Hz	1,2,208-230,60	1,2,208-230,60		
	Heat Exchanger	Type		-	Fin & Tube	Fin & Tube		
		Material	Fin	-	Al	Al		
			Tube	-	Cu	Cu		
	Fin Treatment		-	Green Hydrophile	Green Hydrophile			
	Fan	Type		-	Turbo(3D)	Turbo(3D)		
		Quantity		EA	1	1		
		Air Flow Rate	H/M/L		m ³ /min	28.2/23.6/17.8	34.2/25.8/19.0	
					ft ³ /min	996/833/629	1208/911/671	
					l/s	470/393/297	570/430/317	
	External Static Pressure	Min/Std/Max	In Wg	-	-			
	Fan Motor	Type		-	BLDC	BLDC		
		Output		W x n	97 x 1	97 x 1		
	Drain	Drain Pipe		Φ, mm	OD26.67	OD26.67		
	Sound	Sound Pressure Level	H/M/L		dB(A)	37/34/30		
					dB(A)	53		
	External Dimension	Net Weight		kg(lbs)	19.0(41.9)	21.2(46.7)		
		Gross Weight		kg(lbs)	22.5(49.6)	24.8(54.7)		
		Net Dimensions (WxHxD)		mm	840 x 288 x 840	840 x 288 x 840		
				inch	33.07 x 11.34 x 33.07	33.07 x 11.34 x 33.07		
Gross Dimensions (WxHxD)			mm	898 x 357 x 898	898 x 357 x 898			
		inch	35.35 x 14.06 x 35.35	35.35 x 14.06 x 35.35				

1. Specification

Wind-Free 4Way Cassette

Model Name		Indoor Unit		AC030BN4DCH/AA	AC036BN4DCH/AA	
		Outdoor Unit		AC030BXSCCH/AA	AC036BXSCCH/AA	
US Code		Indoor Unit		CNH304DB	CNH364DB	
		Outdoor Unit		CXH30SCB	CXH36SCB	
Indoor Unit	Casing	Material		-	Polypropylene	
		Model Name		-	PC4NUFMUN	
	Panel	Type		-	Wind-Free Type	Wind-Free Type
		Material		-	HIPS	HIPS
		Color		-	DA White	DA White
		Net Weight		kg(lbs)	6.3 (13.9)	6.3 (13.9)
		Gross Weight		kg(lbs)	8.7 (19.2)	8.7 (19.2)
		Net Dimensions (WxHxD)		mm	950 x 64 x 950	950 x 64 x 950
				inch	37.4 x 2.5 x 37.4	37.4 x 2.5 x 37.4
	Gross Dimensions (WxHxD)		mm	1,010 x 117 x 1,000	1,010 x 117 x 1,000	
			inch	39.8 x 4.6 x 39.4	39.8 x 4.6 x 39.4	
	Control System	Infrared remote control		-	AR-EH04U	AR-EH04U
		Wired remote control		-	MWR-WG00UN / MWR-SH11UN	MWR-WG00UN / MWR-SH11UN
	Drain Pump	Drain Pump		-	Included	Included
Max.lifting Height / Displacement		in / gal/h	29-5/16 6.34gal/h	29-5/16 6.34gal/h		
Additional Accessories	Air Filter		-	Removable / Washable	Removable / Washable	
	Power Supply		Φ,#,V,Hz	1,2,208-230,60	1,2,208-230,60	
Outdoor Unit	Heat Exchanger	Type		-	Fin & Tube	
		Material	Fin	-	Al	Al
			Tube	-	Cu	Cu
		Fin Treatment		-	Anti-Corrosion	Anti-Corrosion
	Compressor	Model		-	ATQ420D1UNT1	ATQ420D1UNT1
		Type		-	Twin BLDC	Twin BLDC
		Output		kW	3.44	3.44
		Oil	Type	-	POE	POE
	Initial Charge		cc (fl oz)	1500	1500	
	Fan	Type		-	Propeller	Propeller
		Discharge direction		-	Front	Front
		Quantity		EA	2	2
		Air Flow Rate	H/M/L	m ³ /min	125	125
				ft ³ /min	4,414	4,414
			l/s	2,083	2,083	
	Fan Motor	Type		-	BLDC	BLDC
Output		W x n	125 x 2	125 x 2		
Sound	Sound Pressure Level	Cooling	dB(A)	49	49	
		Heating	dB(A)	50	51	
	Sound Power Level		dB(A)	67	69	
External Dimension	Net Weight		kg(lbs)	100.0 (220.5)	100.0 (220.5)	
	Gross Weight		kg(lbs)	110.0 (242.5)	110.0 (242.5)	
	Net Dimensions (WxHxD)		mm	940 x 1,420 x 330	940 x 1,420 x 330	
			inch	37.01 x 55.91 x 12.99	37.01 x 55.91 x 12.99	
	Gross Dimensions (WxHxD)		mm	995 x 1,598 x 426	995 x 1,598 x 426	
inch			37.17 x 62.91 x 16.77	37.17 x 62.91 x 16.77		
Casing	Material	Body	-	Steel	Steel	
Operating Temp. Range	Cooling		°C (°F)	-20~50 (-4~122)	-20~50 (-4~122)	
	Heating		°C (°F)	-25~24 (-13~75)	-25~24 (-13~75)	

NOTE

- Specification may be subject to change without prior notice.
 - 1) Performances are based on the following test conditions.
 - Cooling : Indoor temperature : 80°F(26.7°C) DB, 67°F(19.4°C) WB, Outdoor temperature : 95°F(35°C) DB, 75°F(23.9°C) WB
 - Heating : Indoor temperature : 70°F(21.1°C) DB, 60°F(15.6°C) WB, Outdoor temperature : 47°F(8.3°C) DB, 43°F(6.1°C) WB
 - Equivalent refrigerant piping length 7.5m(24.6ft), Level differences : 0m(0ft)
 - 2) Select wire size based on the value of MCA.
 - 3) Sound pressure level is obtained in an anechoic room.
 - Sound pressure level is a relative value, depending on the distance and acoustic environment.
 - Sound pressure level may differ depending on operation condition.
 - dBA = A-weighted sound pressure level / Reference acoustic pressure 0 dB = 20uPa
 - 4) Sound power level is an absolute value that a sound source generates.
 - dBA = A-weighted sound power level
 - Reference power : 1pW / Measured according to ISO 3741
 - 5) These products contain R410A which is fluorinated greenhouse gas.

2. Summary Table

Wind-Free 4Way Cassette

Performance Characteristics

Model Code	Net Weight (lbs)	Capacity		Fan Speed	Airflow (Cooling/Heating) (CFM)	Sound Pressure Level (dBA)	Sound Power Level (dBA)	
		Cooling (Btu/h)	Heating (Btu/h)					
CNH304DB (AC030BN4DCH/AA)	41.9	Max.	36,000	40,000	High	996 / 996	37	53
		Std.	30,000	34,000	Mid	833 / 833	34	-
		Min.	13,000	10,000	Low	629 / 629	30	-
CNH364DB (AC036BN4DCH/AA)	46.7	Max.	42,000	45,000	High	1,208 / 1,208	43	59
		Std.	36,000	40,000	Mid	911 / 911	38	-
		Min.	14,000	10,500	Low	671 / 671	33	-

NOTE

- Sound data is based on cooling operation.

Electric Characteristics

Model		Outdoor Unit				Input Current (Amperes)			Power Supply		
Indoor Unit	Outdoor Unit	Rated Hz	Voltage range		Outdoor Unit		Indoor Unit	Total	MCA(A)	MOP(A)	
			Volts	Min.	Max	Cooling					Heating
CNH304DB (AC030BN4DCH/AA)	CXH30SCB(AC030BXSCCH/AA)	60	208 to 230	187	253	29.57	29.57	0.79	30.36	32.1	40
CNH364DB (AC036BN4DCH/AA)	CXH36SCB(AC036BXSCCH/AA)	60	208 to 230	187	253	29.57	29.57	0.79	30.36	33.2	40

NOTE

- MCA : Minimum circuit amperes
- MOP: Maximum Overcurrent Protective Device
- Select wire size based on the value of MCA

3. Capacity Table

Wind-Free 4Way Cassette

(1) CNH304DB(AC030BN4DCH/AA) + CXH30SCB(AC030BXSCCH/AA)

Cooling

TC : Total Capacity, SHC : Sensible Heat Capacity, PI : Power Input

Outdoor Temp. (°F, DB)	Indoor Temperature (°F, DB / WB)																				
	68 / 57			72 / 61			77 / 64			80 / 67			82 / 70			86 / 72			90 / 75		
	TC	SHC	PI	TC	SHC	PI	TC	SHC	PI	TC	SHC	PI	TC	SHC	PI	TC	SHC	PI	TC	SHC	PI
0	30.5	22.0	1.71	32.1	22.7	1.74	33.5	23.4	1.78	34.5	24.2	1.82	35.2	23.9	1.83	36.9	23.7	1.85	38.8	23.2	1.89
70	33.2	24.0	1.71	34.9	24.7	1.74	36.4	25.5	1.78	37.5	26.3	1.82	38.3	26.0	1.83	40.2	25.7	1.85	42.2	25.2	1.89
95	26.5	19.2	2.14	27.9	19.8	2.18	29.1	20.4	2.22	30.0	21.0	2.27	30.6	20.8	2.29	32.1	20.6	2.32	33.7	20.2	2.36
115	31.8	23.0	3.95	33.5	23.7	4.03	34.9	24.4	4.12	36.0	25.2	4.20	36.7	24.9	4.24	38.6	24.7	4.28	40.5	24.2	4.37
122	29.2	21.1	3.63	30.7	21.7	3.71	32.0	22.4	3.78	33.0	23.1	3.86	33.7	22.9	3.90	35.3	22.6	3.94	37.1	22.2	4.01

Heating

TC : Total Capacity, PI : Power Input

Outdoor Temperature (°F, DB)	Indoor Temperature (°F, DB)											
	61		64		68		70		72		75	
	TC	PI	TC	PI	TC	PI	TC	PI	TC	PI	TC	PI
-13	28.0	4.91	27.7	4.87	27.5	4.82	27.2	4.77	26.9	4.72	26.7	4.68
-4	35.0	5.46	34.7	5.41	34.3	5.35	34.0	5.30	33.7	5.25	33.3	5.19
14	38.5	4.67	38.2	4.62	37.8	4.58	37.4	4.53	37.0	4.49	36.7	4.44
32	40.3	4.40	39.9	4.36	39.5	4.32	39.1	4.27	38.7	4.23	38.3	4.19
47	35.0	2.67	34.7	2.64	34.3	2.62	34.0	2.59	33.7	2.56	33.3	2.54
75.2	43.8	2.80	43.4	2.77	42.9	2.75	42.5	2.72	42.1	2.69	41.7	2.67

NOTE

- The performance table shows the average value of each conditions.

3. Capacity Table

Wind-Free 4Way Cassette

(2) CNH364DB(AC036BN4DCH/AA) + CXH36SCB(AC036BXSCCH/AA)

Cooling

TC : Total Capacity, SHC : Sensible Heat Capacity, PI : Power Input

Outdoor Temp. (°F, DB)	Indoor Temperature (°F, DB / WB)																				
	68 / 57			72 / 61			77 / 64			80 / 67			82 / 70			86 / 72			90 / 75		
	TC	SHC	PI	TC	SHC	PI	TC	SHC	PI	TC	SHC	PI	TC	SHC	PI	TC	SHC	PI	TC	SHC	PI
0	35.0	25.3	2.22	36.9	26.1	2.26	38.4	26.9	2.31	39.6	27.7	2.35	40.4	27.4	2.38	42.4	27.2	2.40	44.5	26.6	2.45
70	39.8	28.7	2.35	41.9	29.6	2.39	43.7	30.6	2.44	45.0	31.5	2.49	45.9	31.2	2.52	48.2	30.9	2.54	50.6	30.3	2.59
95	31.8	23.0	2.61	33.5	23.7	2.66	34.9	24.4	2.71	36.0	25.2	2.77	36.7	24.9	2.80	38.6	24.7	2.83	40.5	24.2	2.88
115	33.4	24.1	4.12	35.2	24.9	4.20	36.7	25.7	4.29	37.8	26.5	4.38	38.6	26.2	4.42	40.5	25.9	4.46	42.5	25.4	4.55
122	30.3	23.4	3.78	31.8	24.1	3.86	33.2	24.9	3.94	34.2	25.7	4.02	34.9	25.4	4.06	36.6	25.1	4.10	38.5	24.6	4.18

Heating

TC : Total Capacity, PI : Power Input

Outdoor Temperature (°F, DB)	Indoor Temperature (°F, DB)											
	61		64		68		70		72		75	
	TC	PI	TC	PI	TC	PI	TC	PI	TC	PI	TC	PI
-13	33.0	5.05	32.6	5.00	32.3	4.95	32.0	4.90	31.7	4.85	31.4	4.80
-4	41.2	5.67	40.8	5.61	40.4	5.56	40.0	5.50	39.6	5.45	39.2	5.39
14	43.3	4.87	42.8	4.82	42.4	4.77	42.0	4.73	41.6	4.68	41.2	4.63
32	47.4	4.71	46.9	4.67	46.5	4.62	46.0	4.58	45.5	4.53	45.1	4.48
47	41.2	3.14	40.8	3.11	40.4	3.08	40.0	3.05	39.6	3.02	39.2	2.99
75.2	53.6	3.61	53.0	3.58	52.5	3.54	52.0	3.51	51.5	3.47	51.0	3.44

NOTE

- The performance table shows the average value of each conditions.

4. Dimensional Drawing

Wind-Free 4Way Cassette

Units : mm [inches]

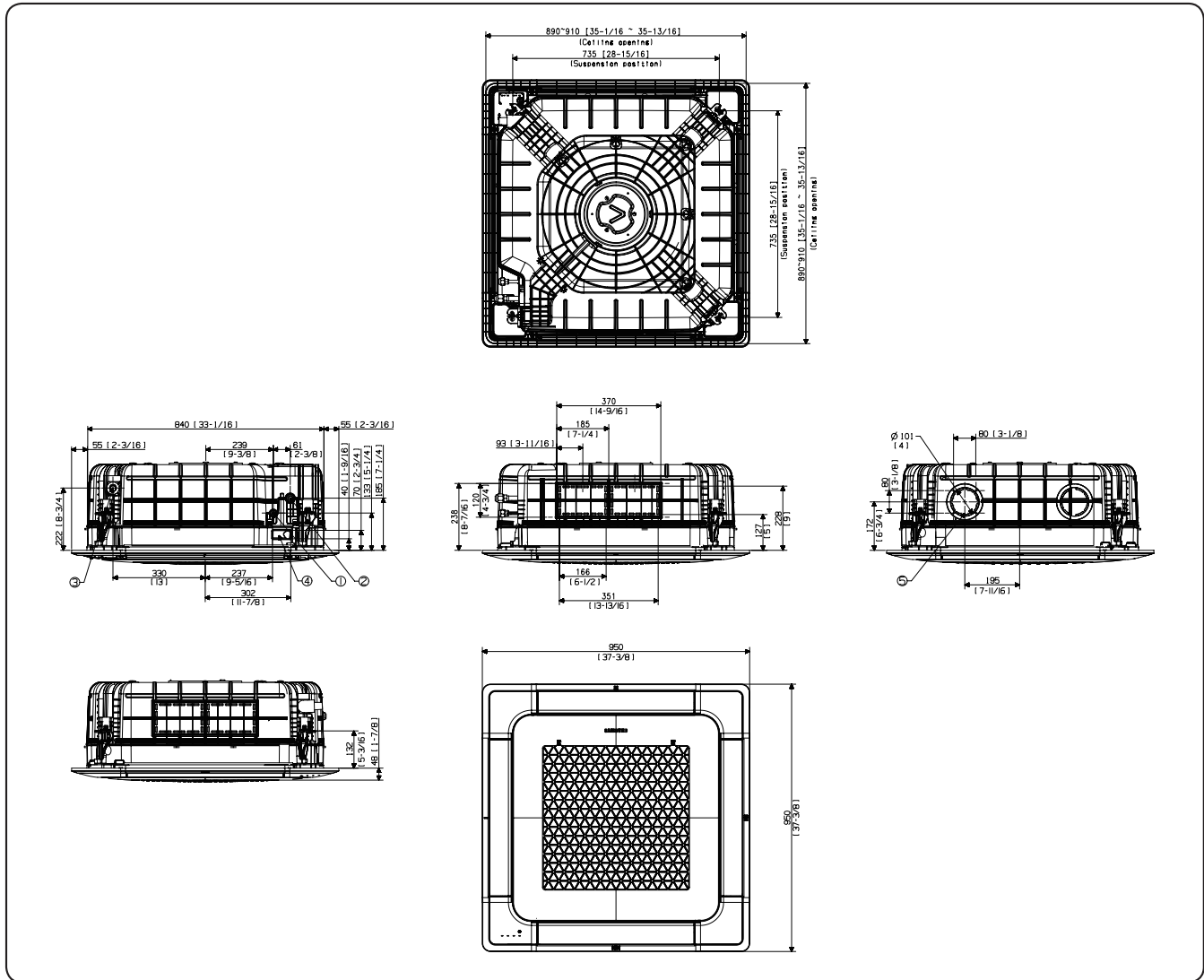

No.	Name	Description
1	Liquid pipe connection	Φ 9.52mm(3/8")
2	Gas pipe connection	Φ 15.88mm(5/8")
3	Drain pipe connection	VP25[OD32mm(1.26"), ID25mm(0.98")]
4	Power supply & Communication wiring conduit	
5	Fresh air intake knockout hole	Φ101mm(4") , Use M4 Screw

NOTE

- As for suspension bolt, please use M8 ~ M10. (Procured at local site)

5. Center of Gravity

Wind-Free 4Way Cassette

Units : mm [inches]

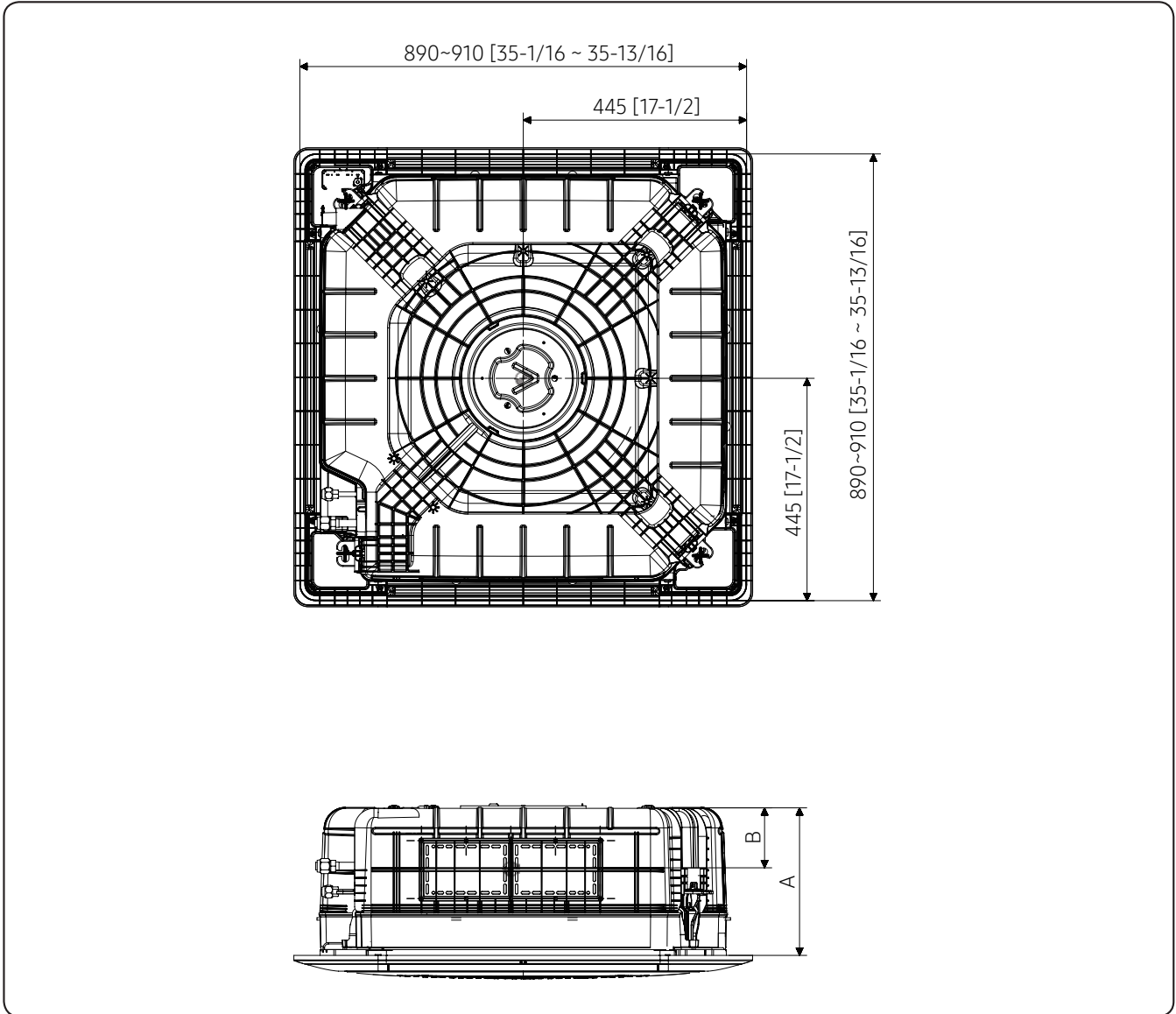

A	B
305 [12]	130 [5-1/8]

6. Electrical Wiring Diagram

Wind-Free 4Way Cassette

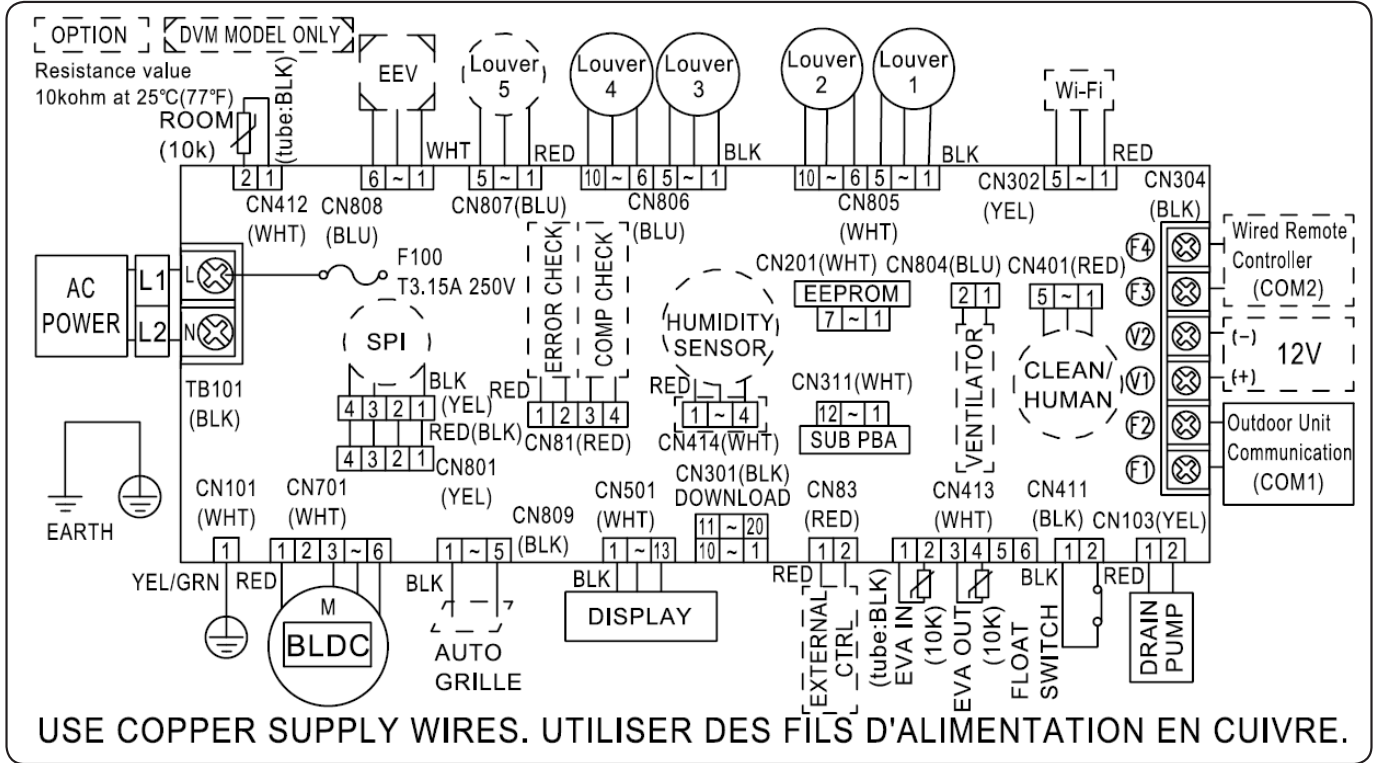

SUB PBA	Printed Circuit Board(SUB)	SPI	S-Plasma ion	ROOM(10K)	Thermistor ROOM OUT(10K)
M-BLDC	BLDC Motor	EEV	Electronic Expansion Valve	EVA-IN(10K)	Thermistor EVA IN(10K)
		EXT_CONTROL	EXTERNAL_CONTROL	EVA-OUT(10K)	Thermistor EVA OUT(10K)

NOTE

- This wiring diagram applies only to the Indoor unit.
- Symbols show as follow :
blk: black, red: red, blu: blue, wht: white, yel: yellow, brn: brown, sky: skyblue: grn: green
- For connection wiring indoor-outdoor transmission F1-F2, indoor-wired remote controller transmission F3-F4.
- ⊕ Protective earth(screw), □□□□ : connector, $\frac{N}{\times}$: The wire quantity

7. Sound Data

Wind-Free 4Way Cassette

Sound Pressure level

Unit: dB(A)

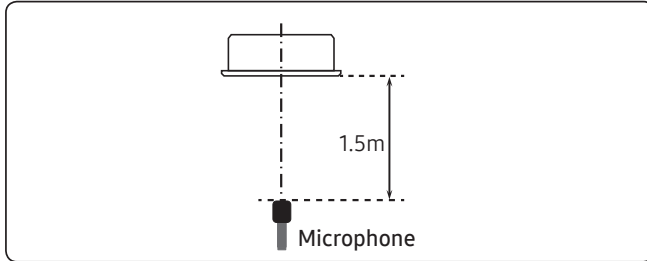

Model	High	Mid	Low
CNH304DB (AC030BN4DCH/AA)	37	34	30
CNH364DB (AC036BN4DCH/AA)	43	38	33

- NC Curve

1) CNH304DB (AC030BN4DCH/AA)

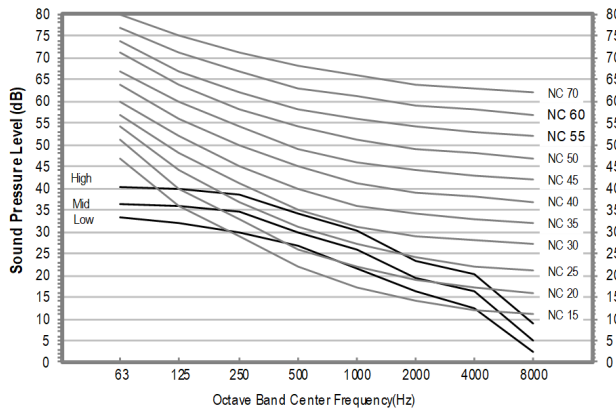

2) CNH364DB (AC036BN4DCH/AA)

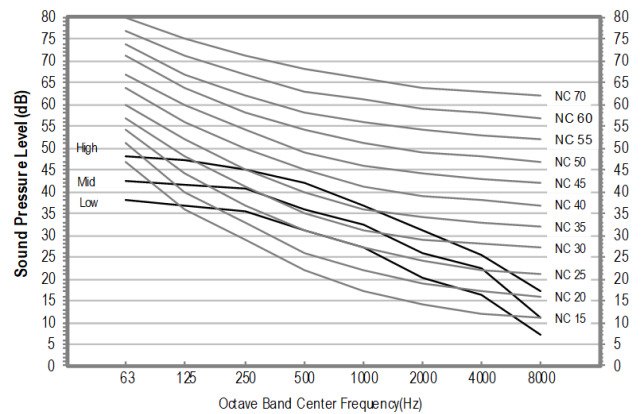

NOTE

- Specifications may be subject to change without prior notice.
 - Sound pressure level is obtained in an anechoic room.
 - Sound pressure level is a relative value, depending on the distance and acoustic environment.
 - Sound pressure level may differ depending on operation condition.
 - dBA = A weighted sound pressure level
 - Reference acoustic pressure 0 dB = 20μPa

7. Sound Data

Wind-Free 4Way Cassette

Sound Power level

NOTE

Unit: dB(A)

- Specifications may be subject to change without prior notice
 - Sound power level is an absolute value that a sound source generates.
 - dBA = A-weighted sound power level.
 - Reference power : 1pW.
 - Measured according to ISO 3741.

Model	Cooling
CNH304DB (AC030BN4DCH/AA)	53
CNH364DB (AC036BN4DCH/AA)	59

- NC Curve

1) CNH304DB (AC030BN4DCH/AA)

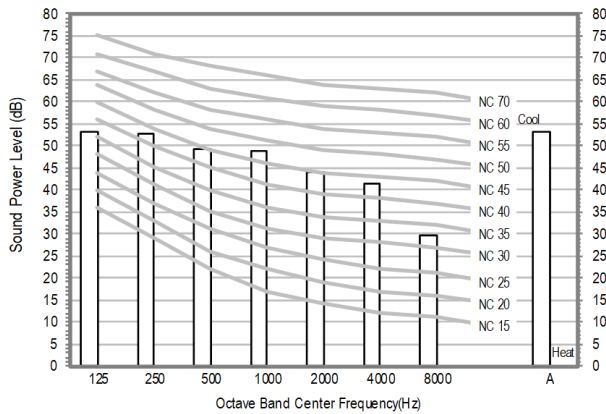

2) CNH364DB (AC036BN4DCH/AA)

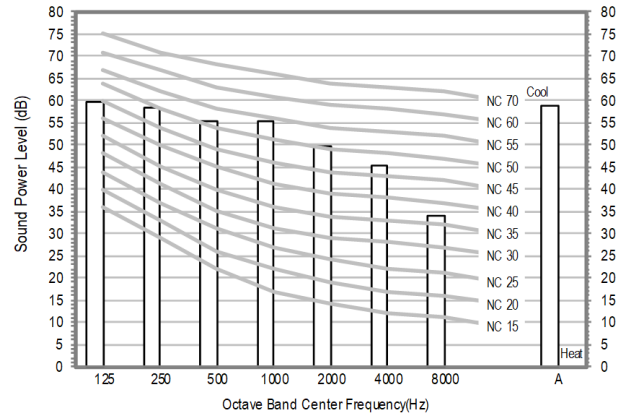

8. Temperature and air flow distribution

Wind-Free 4Way Cassette

CNH304DB (AC030BN4DCH/AA)

- Cooling Air Velocity distribution
(Discharge angle : 45 degree)

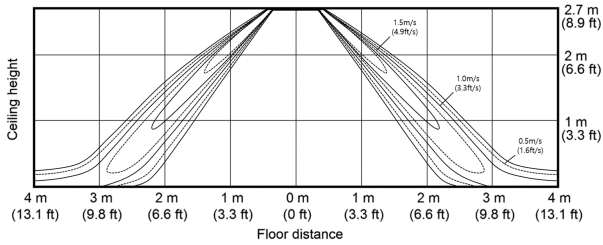

- Cooling temperature distribution
(Discharge angle : 45 degree)

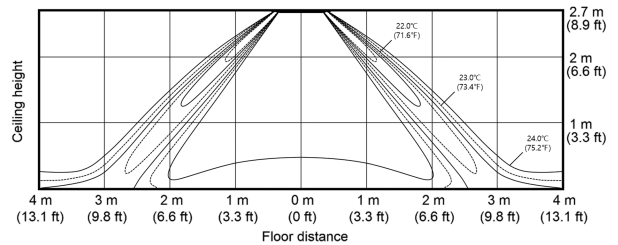

- Heating Air Velocity distribution
(Discharge angle : 52 degree)

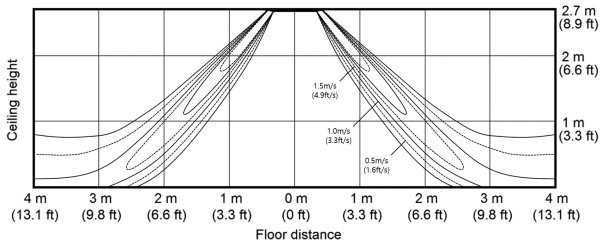

- Heating temperature distribution
(Discharge angle : 52 degree)

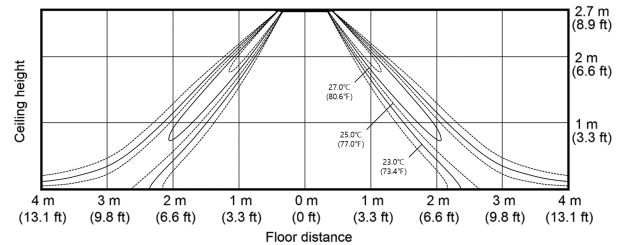

CNH364DB (AC036BN4DCH/AA)

- Cooling Air Velocity distribution
(Discharge angle : 45 degree)

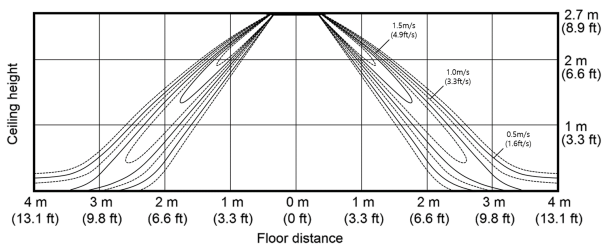

- Cooling temperature distribution
(Discharge angle : 45 degree)

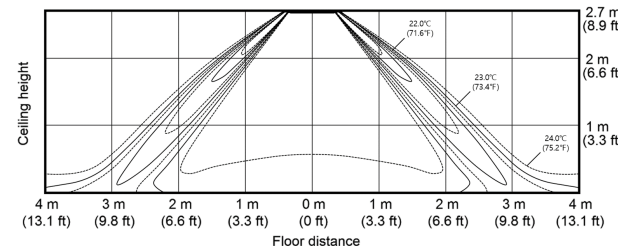

- Heating Air Velocity distribution
(Discharge angle : 52 degree)

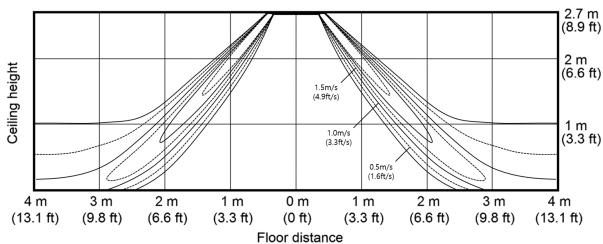

- Heating temperature distribution
(Discharge angle : 52 degree)

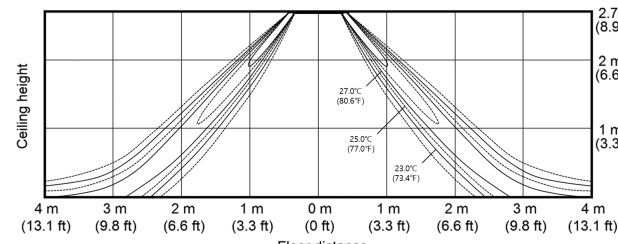

Duct S

1. Specification	25
2. Summary Table	27
3. Capacity Table	28
4. Dimensional Drawing	30
5. Center of Gravity	32
6. Electrical Wiring Diagram	33
7. Sound Data	34
8. Temperature and air flow distribution	36

Features & Benefits

Duct S

Overview

Samsung Ducted Type air conditioning units are a smart solution for low-maintenance, consistent cooling and heating performance in any environment. Their compact, slim frame blends seamlessly into ceilings, enhancing the beauty of the interior space and affording users more flexible installation options. Offering a comprehensive lineup, Samsung Ducted Type air conditioning units offer just the right solution for every need--from the office or shop to the restaurant kitchen.

Experience performance and convenient comfort for any weather condition

Samsung Duct S delivers unparalleled cooling and heating and flexible management with customizable comfort settings in any climate—all year round. Plus, it boasts a slim, compact size and multiple access points for easy setup exactly where needed.



Smart pressure control

Samsung Ducted Type units feature a smart pressure control system. This system adjusts the fan speed based on the external static pressure (ESP), delivering consistent cooling and heating power, regardless of the surrounding environment.

Convenient installation

The optional lift-up drain pump lifts condensed water up to 27.6 inch, compared to a limit of 29.5 inch on conventional models, for flexible and convenient installation.

The Duct S indoor air conditioning unit delivers smooth, consistent operation and convenience with features such as:

- Efficient operation. Stage the desired atmosphere with energy-efficient performance and customized airflow.
 - Smart management. Cool spaces efficiently and manage the air conditioning unit even while away, with features designed for efficiency and control.
 - Easy, flexible setup. Install and maintain even multiple units with a compact and easily accessible design.
-

1. Specification

Duct S

Model Name		Indoor Unit		AC030BNHDCH/AA		AC036BNHDCH/AA			
US Code		Indoor Unit		CNH30HDB		CNH36HDB			
		Outdoor Unit		CXH30SCB		CXH36SCB			
System	Mode			-	Heat Pump		Heat Pump		
	Performance	Capacity (Min/Std/Max)	Cooling	kW	4.10/8.79/10.55		4.25/10.55/12.31		
				Btu/h	14,000 / 30,000 / 36,000		14,500 / 36,000 / 42,000		
				US RT	1.17/2.50/3.00		1.21/3.00/3.50		
			Heating	kW	3.08/9.38/11.72		3.22/11.72/14.07		
				Btu/h	10,500 / 32,000 / 40,000		11,000 / 40,000 / 48,000		
				US RT	0.88/2.67/3.33		0.92/3.33/4.00		
	Power	Power Input (Min/Std/Max)	Cooling	kW	0.85 / 2.50 / 3.30		0.87 / 2.95 / 4.00		
			Heating		0.68 / 2.84 / 4.70		0.77 / 3.35 / 5.30		
		Current Input (Min/Std/Max)	Cooling	A	4.5 / 11.4 / 14.5		4.7 / 13.2 / 17.7		
			Heating		3.6 / 13.0 / 20.6		4.2 / 15.0 / 23.3		
		Current	MCA	A	32.1		33.2		
			MOP	A	40		40		
	Efficiency	EER2	Cooling	-	3.52		3.58		
			Cooling(US)	(Btu/h)/W	12.0		12.2		
		COP2	Heating	W/W	3.30		3.50		
		SEER2	-	-	18.7		19.4		
		HSPF2	-	-	8.6		8.8		
	Pipe Connections	Liquid Pipe	Type	-	Flare		Flare		
			Φ, mm(inch)	-	9.52 (3/8)		9.52 (3/8)		
		Gas Pipe	Type	-	Flare		Flare		
			Φ, mm(inch)	-	15.88 (5/8)		15.88 (5/8)		
		Heat Insulation		-	Both liquid and gas pipes		Both liquid and gas pipes		
		Pipe Length (ODU-IDU)	Standard	m (ft)	-	7.5 (24.6)		7.5 (24.6)	
				Max.	m (ft)	75 (246.1)		75 (246.1)	
			Chargeless	Elevation	m (ft)	30 (98.4)		30 (98.4)	
	m (ft)			-	7.5 (24.6)		7.5 (24.6)		
	Wiring Connections	Communication	Min.	mm ²	0.75		0.75		
Remark			-	F1,F2		F1,F2			
Refrigerant	Type		-	R410A		R410A			
	Factory Charging		-	4.0		4.0			
Option Code	Standard		-	01B3FC-1C59B9-275A5E-370020		01B3FC-1C5933-276975-370045			
	Install		-	020010-120000-200000-300000		020010-120000-200000-300000			
Indoor Unit	Power Supply			Φ,#,V,Hz	1,2,208-230,60		1,2,208-230,60		
	Heat Exchanger	Type		-	Fin & Tube		Fin & Tube		
		Material	Fin	-	Al		Al		
			Tube	-	Cu		Cu		
		Fin Treatment		-	Hydrophile		Hydrophile		
	Fan	Type		-	Sirocco		Sirocco		
		Quantity		EA	3		3		
		Air Flow Rate	H/M/L	m ³ /min	26/21.5/17		33/29/24		
				ft ³ /min	918/759/600		1165/1024/848		
				l/s	433/358/283		550/483/400		
	External Static Pressure	Min/Std/Max	In Wg	0.10/0.58/0.79		0.12/0.58/0.79			
	Fan Motor	Type		-	BLDC		BLDC		
		Output		W x n	153		244		
	Drain	Drain Pipe		Φ, mm	OD26.67		OD26.67		
	Sound	Sound Pressure Level	H/M/L	dB(A)	41/37/33		43/39/35		
					63		65		
		Sound Power Level		dB(A)	63		65		
	External Dimension	Net Weight		kg(lbs)	35.0 (77.2)		44.0 (97.0)		
Gross Weight		kg(lbs)	39.5 (87.1)		50.0 (110.2)				
Net Dimensions (WxHxD)		mm		1,200 x 250 x 700		1,300 x 300 x 700			
		inch		51.18 x 11.81 x 25.56		51.18 x 11.81 x 25.56			
Gross Dimensions (WxHxD)		mm		1,429 x 320 x 779		1,529 x 370 x 779			
		inch		56.26 x 15.60 x 30.67		60.20 x 14.57 x 30.67			

1. Specification

Duct S

Model Name		Indoor Unit		AC030BNHDCH/AA	AC036BNHDCH/AA	
US Code		Indoor Unit		AC030BXSCCH/AA	AC036BXSCCH/AA	
		Outdoor Unit		CNH30HDB	CNH36HDB	
		Outdoor Unit		CXH30SCB	CXH36SCB	
Indoor Unit	Casing	Material	-	Steel	Steel	
	Control	Infrared remote control	-	AR-EH04U	AR-EH04U	
	System	Wired remote control	-	MWR-WG00UN/MWR-SH11UN	MWR-WG00UN/MWR-SH11UN	
	Drain Pump	Drain Pump	-	Included	Included	
		Max.lifting Height / Displacement	in / gal/h	29.53 / 6.34	29.53 / 6.34	
	Additional Accessories	Air Filter	-	-	-	
Outdoor Unit	Power Supply		Φ,#,V,Hz	1,2,208-230,60	1,2,208-230,60	
	Heat Exchanger	Type		-	Fin & Tube	Fin & Tube
		Material	Fin	-	Al	Al
			Tube	-	Cu	Cu
	Fin Treatment		-	Green Hydrophile	Green Hydrophile	
	Compressor	Model		-	ATQ420D1UNT1	ATQ420D1UNT1
		Type		-	BLDC	BLDC
		Output		kW	3.44	3.44
		Oil	Type	-	POE	POE
	Initial Charge		cc (fl oz)	1500	1500	
	Fan	Type		-	Propeller	Propeller
		Discharge direction		-	Front	Front
		Quantity		EA	2	2
		Air Flow Rate	H/M/L	m ³ /min	125	125
				ft ³ /min	4,414	4,414
	l/s			2,083	2,083	
	Fan Motor	Type		-	BLDC	BLDC
		Output		W x n	125 x 2	125 x 2
	Sound	Sound Pressure Level	Cooling	dB(A)	49	49
			Heating	dB(A)	50	51
		Sound Power Level		dB(A)	67	69
	External Dimension	Net Weight		kg(lbs)	100.0 (220.5)	100.0 (220.5)
		Gross Weight		kg(lbs)	110.0 (242.5)	110.0 (242.5)
		Net Dimensions (WxHxD)		mm	940 x 1,420 x 330	940 x 1,420 x 330
				inch	37.01 x 55.91 x 12.99	37.01 x 55.91 x 12.99
		Gross Dimensions (WxHxD)		mm	995 x 1,598 x 426	995 x 1,598 x 426
				inch	39.17 x 62.91 x 16.77	39.17 x 62.91 x 16.77
Casing	Material	Body	-	Steel	Steel	
Operating Temp. Range	Cooling		°C (°F)	-20~50 (-4~122)	-20~50 (-4~122)	
	Heating		°C (°F)	-25~24 (-13~75)	-25~24 (-13~75)	

NOTE

- Specification may be subject to change without prior notice.
- 1) Performances are based on the following test conditions.
 - Cooling : Indoor temperature : 80°F(26.7°C) DB, 67°F(19.4°C) WB, Outdoor temperature : 95°F(35°C) DB, 75°F(23.9°C) WB
 - Heating : Indoor temperature : 70°F(21.1°C) DB, 60°F(15.6°C) WB, Outdoor temperature : 47°F(8.3°C) DB, 43°F(6.1°C) WB
 - Equivalent refrigerant piping length 7.5m(24.6ft), Level differences : 0m(0ft)
- 2) Select wire size based on the value of MCA
- 3) Sound pressure level is obtained in an anechoic room.
 - Sound pressure level is a relative value, depending on the distance and acoustic environment.
 - Sound pressure level may differ depending on operation condition.
 - dBA = A-weighted sound pressure level / Reference acoustic pressure 0 dB = 20uPa
- 4) Sound power level is an absolute value that a sound source generates.
 - dBA = A-weighted sound power level
 - Reference power : 1pW / Measured according to ISO 3741
- 5) These products contain R410A which is fluorinated greenhouse gas.

2. Summary Table

Duct S

Performance Characteristics

Model Code	Net Weight (lbs)	Capacity		Fan Speed	Airflow (Cooling/Heating) (CFM)	Sound Pressure Level (dBA)	Sound Power Level (dBA)	
		Cooling (Btu/h)	Heating (Btu/h)					
CNH30HDB+CXH30SCB (AC030BNHDCH/AA +AC030BXSCCH/AA)	77.2	Max.	36,000	40,000	High	918 / 918	41	63
		Std.	30,000	32,000	Mid	759 / 759	37	-
		Min.	14,000	10,500	Low	600 / 600	33	-
CNH36HDB+CXH36SCB (AC036BNHDCH/AA +AC036BXSCCH/AA)	97.0	Max.	42,000	48,000	High	1,165 / 1,165	43	65
		Std.	36,000	40,000	Mid	1,024 / 1,024	39	-
		Min.	14,500	11,000	Low	848 / 848	35	-

 **NOTE** • Sound data is based on cooling operation.

Electric Characteristics

Model		Outdoor Unit				Input Current (Amperes)				Power Supply	
Indoor Unit	Outdoor Unit	Rated	Voltage range		Outdoor Unit		Indoor Unit	Total	MCA(A)	MOP(A)	
		Hz	Volts	Min.	Max	Cooling					Heating
CNH30HDB (AC030BNHDCH/AA)	CXH30SCB(AC030BXSCCH/AA)	60	208 to 230	187	253	29.57	29.57	2.10	31.67	32.1	40
CNH36HDB (AC036BNHDCH/AA)	CXH36SCB(AC036BXSCCH/AA)	60	208 to 230	187	253	29.57	29.57	3.50	33.07	33.2	40

 **NOTE**

- MCA : Minimum circuit amperes
- MOP: Maximum Overcurrent Protective Device
- Select wire size based on the value of MCA

3. Capacity Table

Duct S

(1) CNH30HDB(AC030BNHDCH/AA) + CXH30SCB (AC030BXSCCH/AA)

Cooling

TC : Total Capacity, SHC : Sensible Heat Capacity, PI : Power Input

Outdoor Temp. (°F, DB)	Indoor Temperature (°F, DB / WB)																				
	68 / 57			72 / 61			77 / 64			80 / 67			82 / 70			86 / 72			90 / 75		
	TC	SHC	PI	TC	SHC	PI	TC	SHC	PI	TC	SHC	PI	TC	SHC	PI	TC	SHC	PI	TC	SHC	PI
	MBH	MBH	kW	MBH	MBH	kW	MBH	MBH	kW	MBH	MBH	kW	MBH	MBH	kW	MBH	MBH	kW	MBH	MBH	kW
0	30.5	22.0	1.88	32.1	22.7	1.92	33.5	23.4	1.96	34.5	24.2	2.00	35.2	23.9	2.02	36.9	23.7	2.04	38.8	23.2	2.08
70	33.2	24.0	1.88	34.9	24.7	1.92	36.4	25.5	1.96	37.5	26.3	2.00	38.3	26.0	2.02	40.2	25.7	2.04	42.2	25.2	2.08
95	26.5	19.2	2.35	27.9	19.8	2.40	29.1	20.4	2.45	30.0	21.0	2.50	30.6	20.8	2.53	32.1	20.6	2.55	33.7	20.2	2.60
115	31.8	23.0	4.35	33.5	23.7	4.44	34.9	24.4	4.53	36.0	25.2	4.63	36.7	24.9	4.67	38.6	24.7	4.72	40.5	24.2	4.81
122	29.2	21.1	4.00	30.7	21.7	4.08	32.0	22.4	4.17	33.0	23.1	4.25	33.7	22.9	4.29	35.3	22.6	4.34	37.1	22.2	4.42

Heating

TC : Total Capacity, PI : Power Input

Outdoor Temperature (°F, DB)	Indoor Temperature (°F, DB)											
	61		64		68		70		72		75	
	TC	PI	TC	PI	TC	PI	TC	PI	TC	PI	TC	PI
	MBH	kW	MBH	kW	MBH	kW	MBH	kW	MBH	kW	MBH	kW
-13	28.0	5.10	27.7	5.05	27.5	5.00	27.2	4.95	26.9	4.90	26.7	4.85
-4	35.0	5.77	34.7	5.71	34.3	5.66	34.0	5.60	33.7	5.54	33.3	5.49
14	36.3	5.12	35.9	5.07	35.6	5.02	35.2	4.97	34.8	4.92	34.5	4.87
32	37.9	4.83	37.5	4.78	37.2	4.73	36.8	4.69	36.4	4.64	36.1	4.59
47	33.0	2.93	32.6	2.90	32.3	2.87	32.0	2.84	31.7	2.81	31.4	2.78
75.2	41.2	3.07	40.8	3.04	40.4	3.01	40.0	2.98	39.6	2.95	39.2	2.92

NOTE

- The performance table shows the average value of each conditions.

3. Capacity Table

Duct S

(2) CNH36HDB(AC036BNHDCH/AA) + CXH36SCB (AC036BXSCCH/AA)

Cooling

TC : Total Capacity, SHC : Sensible Heat Capacity, PI : Power Input

Outdoor Temp. (°F, DB)	Indoor Temperature (°F, DB / WB)																				
	68 / 57			72 / 61			77 / 64			80 / 67			82 / 70			86 / 72			90 / 75		
	TC	SHC	PI	TC	SHC	PI	TC	SHC	PI	TC	SHC	PI	TC	SHC	PI	TC	SHC	PI	TC	SHC	PI
0	35.0	25.3	2.36	36.9	26.1	2.41	38.4	26.9	2.46	39.6	27.7	2.51	40.4	27.4	2.53	42.4	27.2	2.56	44.5	26.6	2.61
70	39.8	28.7	2.50	41.9	29.6	2.55	43.7	30.6	2.60	45.0	31.5	2.66	45.9	31.2	2.68	48.2	30.9	2.71	50.6	30.3	2.76
95	31.8	23.0	2.78	33.5	23.7	2.83	34.9	24.4	2.89	36.0	25.2	2.95	36.7	24.9	2.98	38.6	24.7	3.01	40.5	24.2	3.07
115	33.4	24.1	4.39	35.2	24.9	4.48	36.7	25.7	4.57	37.8	26.5	4.66	38.6	26.2	4.71	40.5	25.9	4.75	42.5	25.4	4.85
122	30.3	23.4	4.03	31.8	24.1	4.11	33.2	24.9	4.19	34.2	25.7	4.28	34.9	25.4	4.32	36.6	25.1	4.36	38.5	24.6	4.45

Heating

TC : Total Capacity, PI : Power Input

Outdoor Temperature (°F, DB)	Indoor Temperature (°F, DB)											
	61		64		68		70		72		75	
	TC	PI	TC	PI	TC	PI	TC	PI	TC	PI	TC	PI
-13	33.0	5.15	32.6	5.10	32.3	5.05	32.0	5.00	31.7	4.95	31.4	4.90
-4	41.2	5.77	40.8	5.71	40.4	5.66	40.0	5.60	39.6	5.54	39.2	5.49
14	43.3	5.35	42.8	5.30	42.4	5.24	42.0	5.19	41.6	5.14	41.2	5.09
32	47.4	5.18	46.9	5.13	46.5	5.08	46.0	5.03	45.5	4.97	45.1	4.93
47	41.2	3.45	40.8	3.42	40.4	3.38	40.0	3.35	39.6	3.32	39.2	3.28
75.2	53.6	3.97	53.0	3.93	52.5	3.89	52.0	3.85	51.5	3.81	51.0	3.78

NOTE

- The performance table shows the average value of each conditions.

4. Dimensional Drawing

Duct S

CNH30HDB (AC030BNHDCH/AA)

Units : mm (inches)

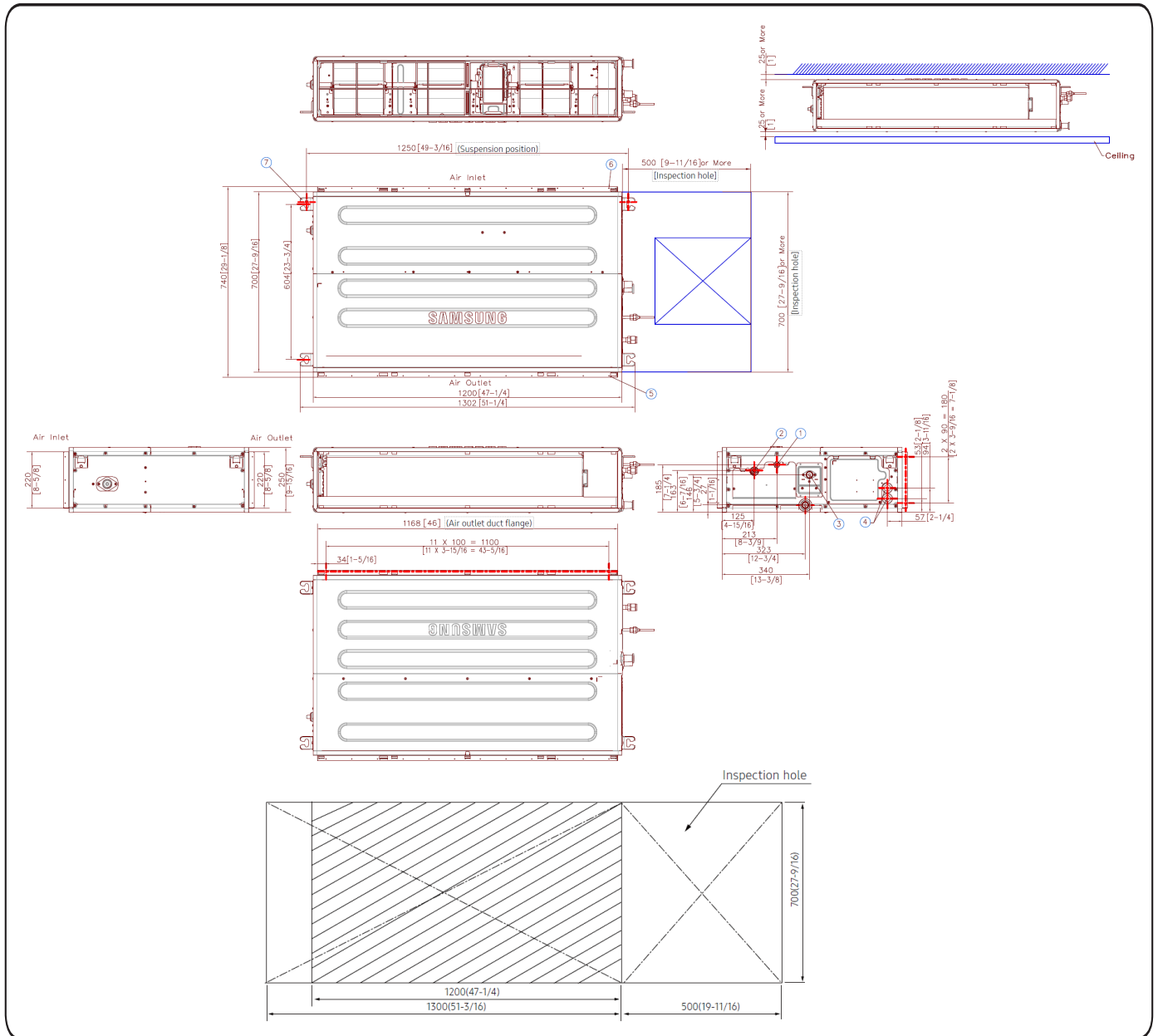

NO	Name	Description
1	Liquid pipe connection	Φ9.52 mm(3/8")
2	Gas pipe connection	Φ15.88 mm(5/8")
3	Drain pipe connection	3/4"[OD26.67mm(1.05")]
4	Power supply connection	-
5	Air discharge flange	-
6	Air suction flange	-
7	Hook	M8~M10

4. Dimensional Drawing

Duct S

CNH36HDB (AC036BNHDCH/AA)

Units : mm (inches)

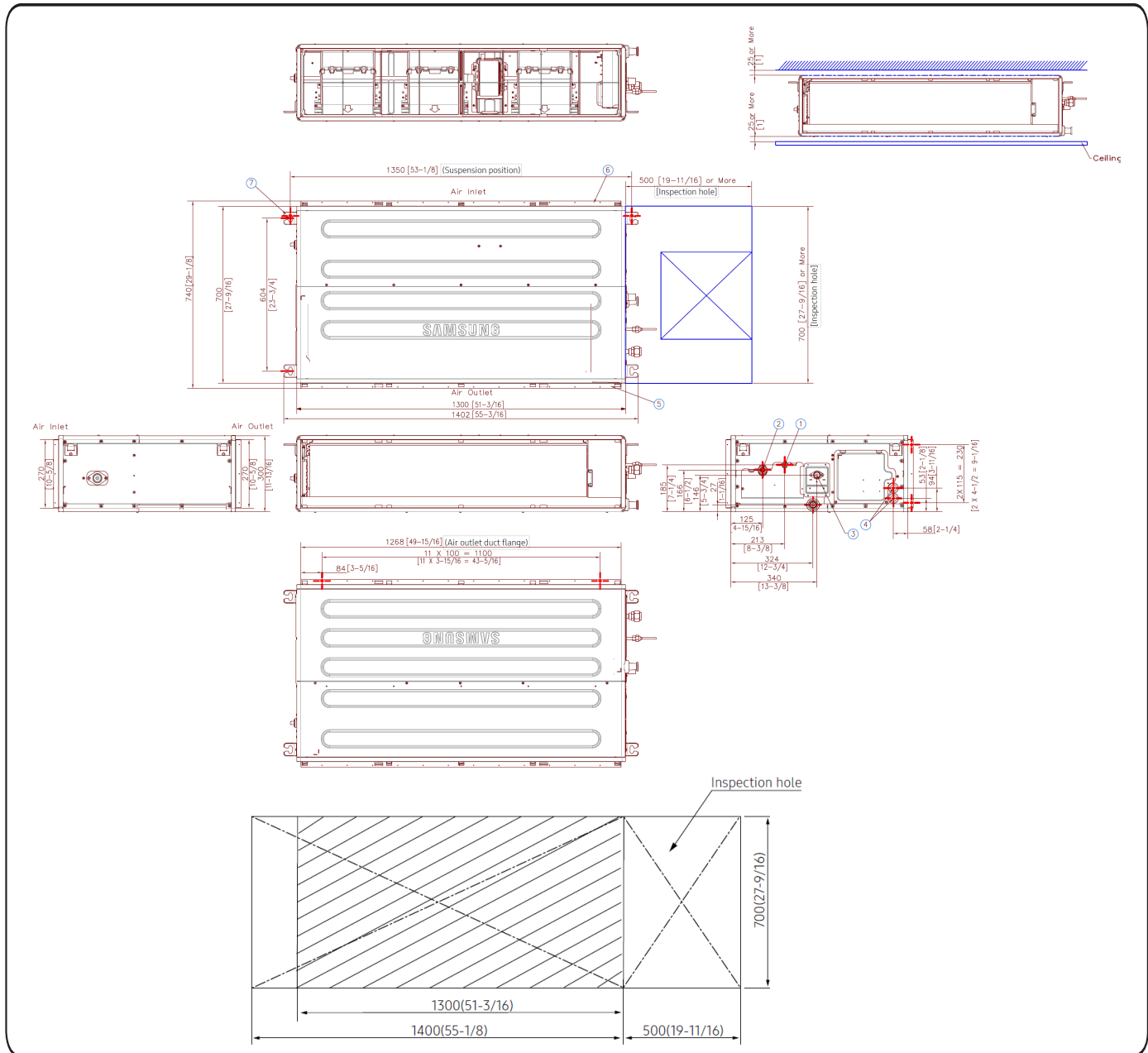

NO	Name	Description
1	Liquid pipe connection	Φ9.52 mm(3/8")
2	Gas pipe connection	Φ15.88 mm(5/8")
3	Drain pipe connection	3/4"[OD26.67mm(1.05")]
4	Power supply connection	-
5	Air discharge flange	-
6	Air suction flange	-
7	Hook	M8-M10

5. Center of Gravity

Duct S

Units : mm [inches]

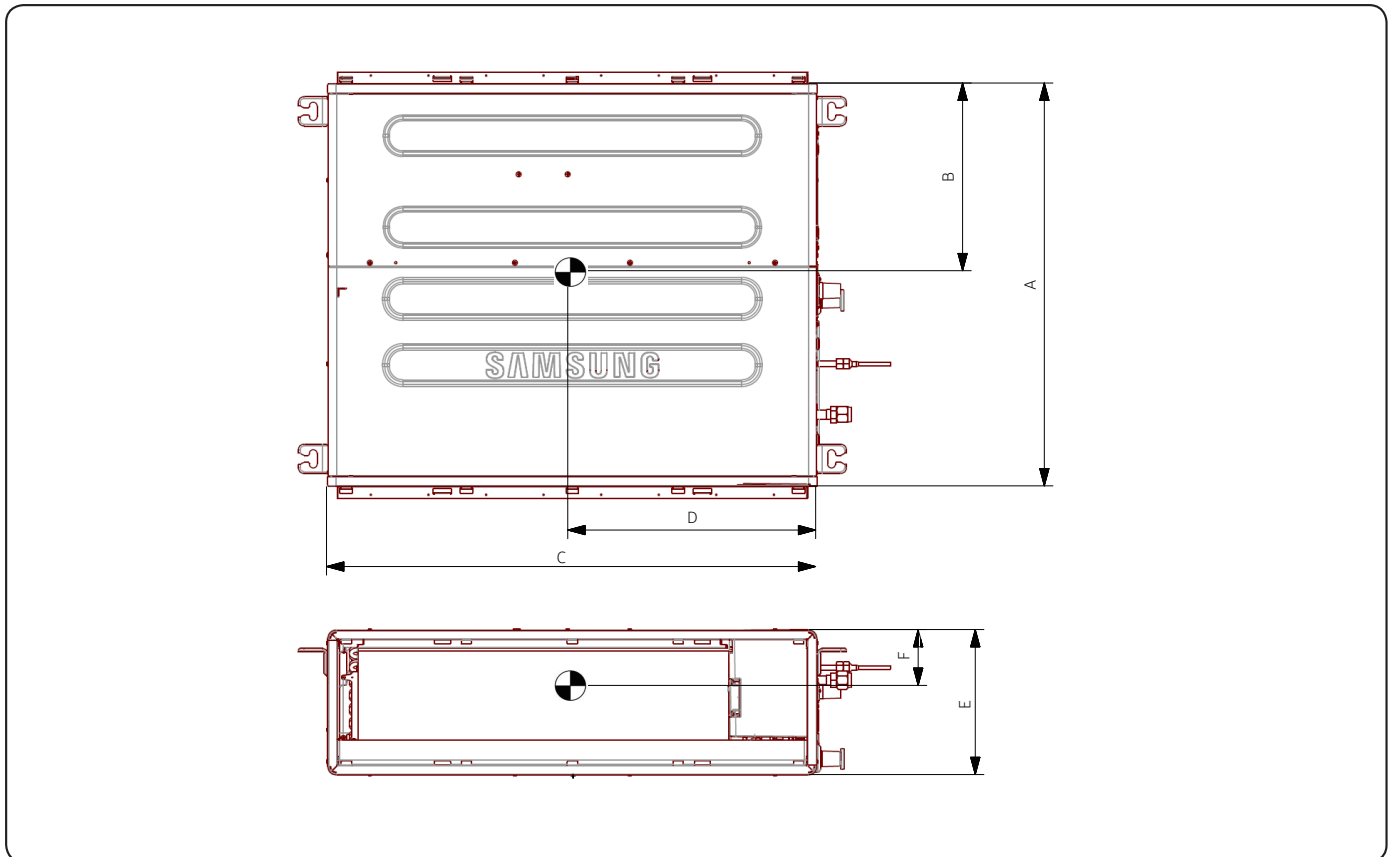

Model	A	B	C	D	E	F
CNH30HDB (AC030BNHDCH/AA)	700 [27-9/16]	265 [10-7/16]	1250 [49-3/16]	565 [18-5/16]	252 [9-15/16]	125 [4-15/16]
CNH36HDB (AC036BNHDCH/AA)	700 [27-9/16]	265 [10-7/16]	1350 [53-1/8]	650 [25-5/8]	301 [11-13/16]	150 [5-15/16]

6. Electrical Wiring Diagram

Duct S

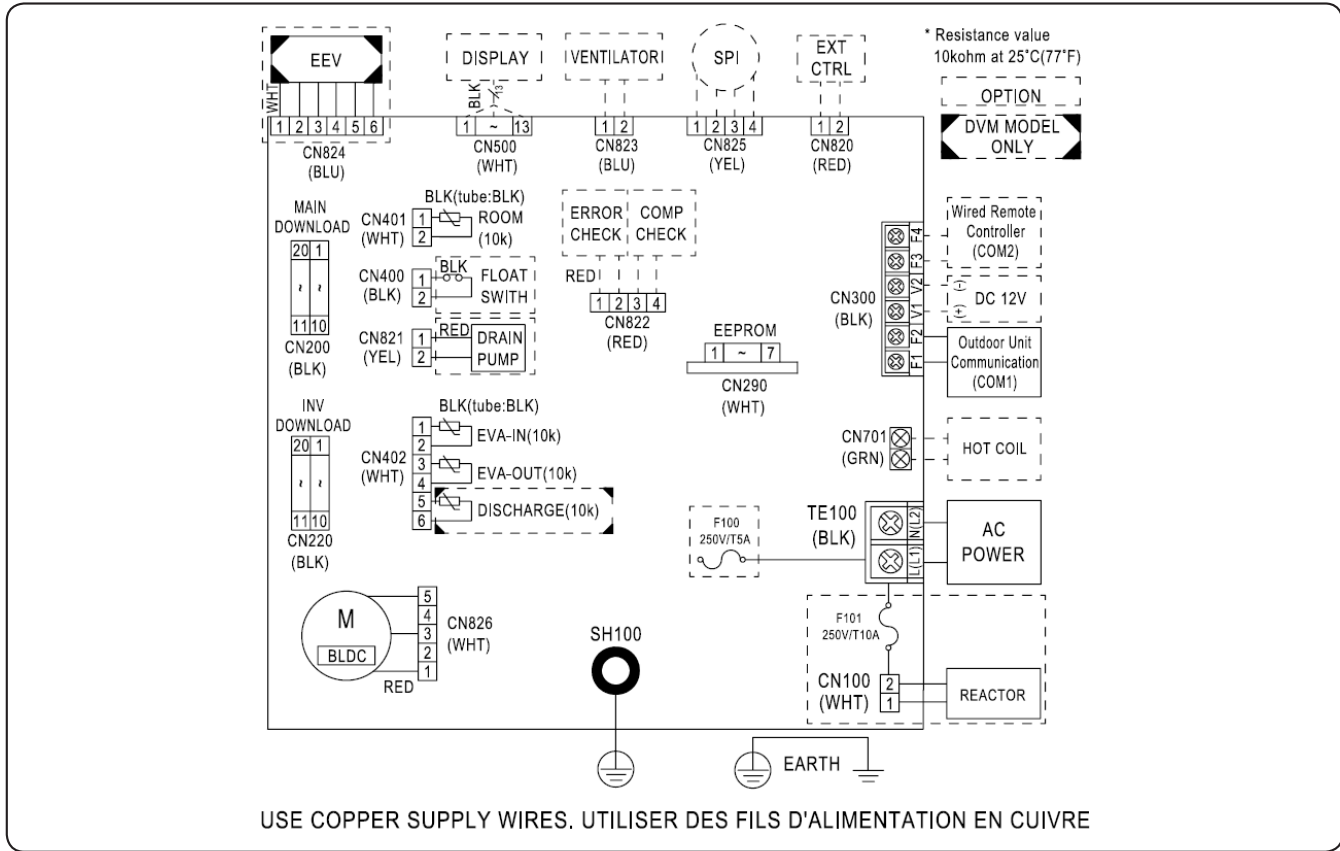

MAIN PBA	Printed circuit board(MAIN)	EEV	Electronic Expansion Valve	ROOM (10K)	Thermistor ROOM in (10K)
EXT_CONTROL	EXTERNAL CONTROL	EVA-IN (10K)	Thermistor EVA IN(10K)	EVA-OUT (10K)	Thermistor EVA OUT(10K)
M-BLDC	BLDC Motor	DISCHARGE(10K)	Thermistor DISCHARGE		

NOTE

- This wiring diagram applies only to the Indoor unit.
- Symbols show as follow :
blk: black, red: red, blu: blue, wht: white, yel: yellow, brn: brown, sky: skyblue: grn: green
- For connection wiring indoor-outdoor transmission F1-F2, indoor-wired remote controller transmission F3-F4.
- Protective earth(screw)

7. Sound Data

Duct S

Sound Pressure level

Unit: dB(A)

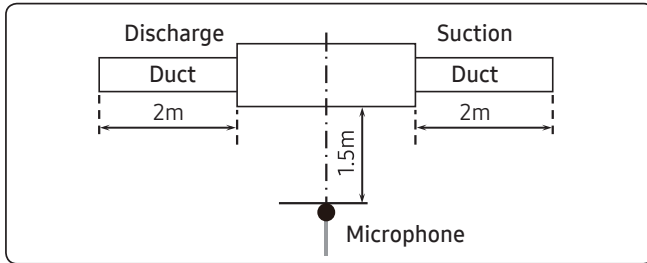

Model	High	Mid	Low
CNH30HDB (AC030BNHDCH/AA)	41	37	33
CNH36HDB (AC036BNHDCH/AA)	43	39	35

- NC Curve

1) CNH30HDB (AC030BNHDCH/AA)

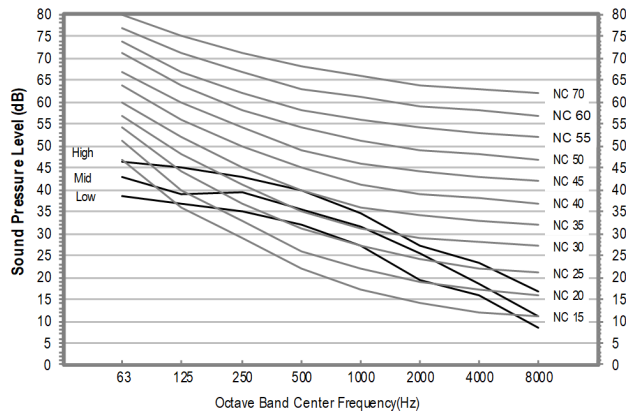

2) CNH36HDB (AC036BNHDCH/AA)

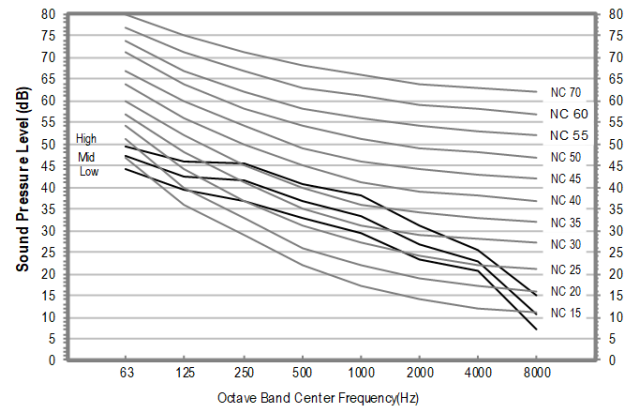

NOTE

- Specifications may be subject to change without prior notice.
 - Sound pressure level is obtained in an anechoic room.
 - Sound pressure level is a relative value, depending on the distance and acoustic environment.
 - Sound pressure level may differ depending on operation condition.
 - dBA = A weighted sound pressure level
 - Reference acoustic pressure 0 dB = 20μPa

7. Sound Data

Duct S

Sound Power level

NOTE

Unit: dB(A)

- Specifications may be subject to change without prior notice
 - Sound power level is an absolute value that a sound source generates.
 - dBA = A-weighted sound power level.
 - Reference power : 1pW.
 - Measured according to ISO 3741.

Model	Cooling
CNH30HDB (AC030BNHDCH/AA)	63
CNH36HDB (AC036BNHDCH/AA)	65

- NC Curve

1) CNH30HDB (AC030BNHDCH/AA)

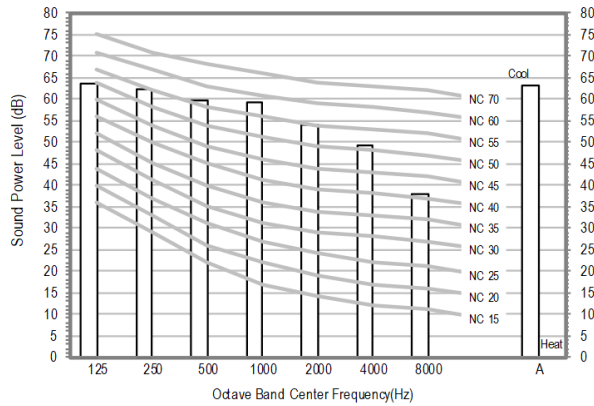

2) CNH36HDB (AC036BNHDCH/AA)

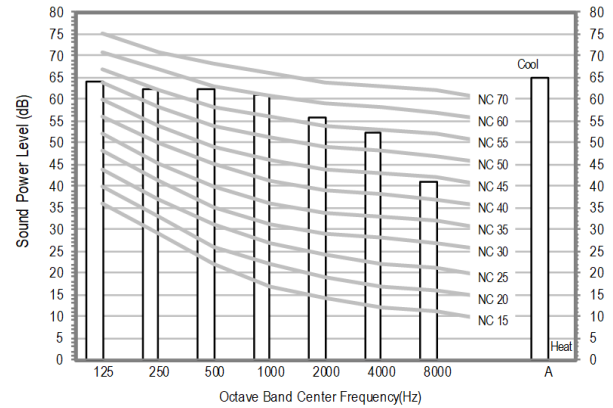

8. Temperature and air flow distribution

Duct S

CNH30HDB (AC030BNHDCH/AA)

①	External Static Pressure(inWg)	Option Code
	0.1 ≤ P ≤ 0.2	01B3FC-1C547B-275A5E-370020

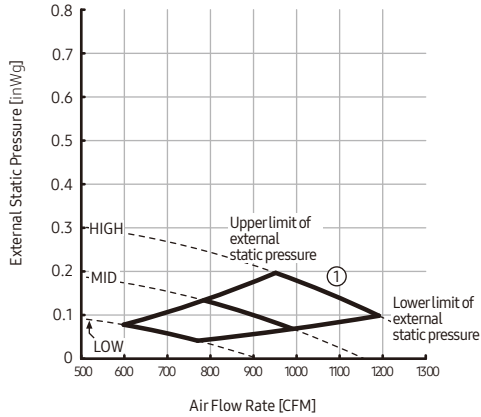

②	External Static Pressure(inWg)	Option Code
	0.2 < P ≤ 0.3	01B3FC-1C54DE-275A5E-370020

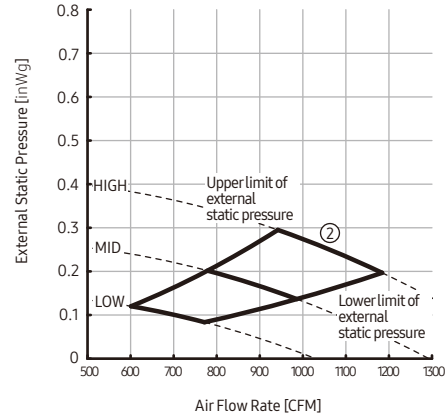

③	External Static Pressure(inWg)	Option Code
	0.3 < P ≤ 0.4	01B3FC-1C5922-275A5E-370020

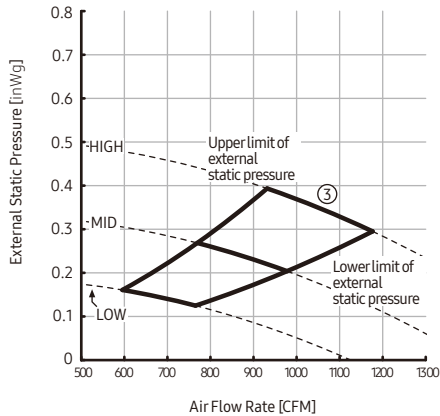

④	External Static Pressure(inWg)	Option Code
	0.4 < P ≤ 0.5	01B3FC-1C5967-275A5E-370020

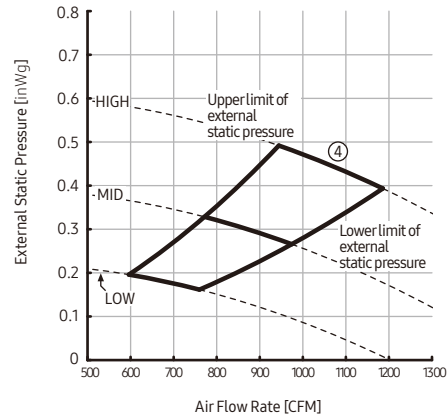

⑤	External Static Pressure(inWg)	Option Code
	0.5 < P ≤ 0.6	01B3FC-1C59B9-275A5E-370020

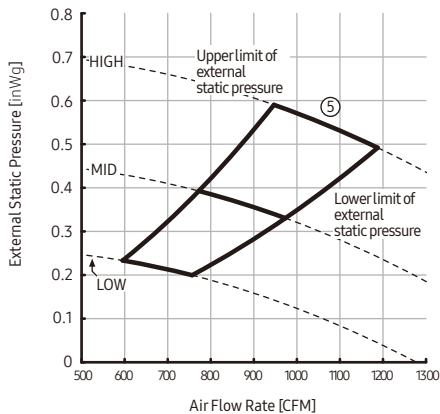

⑥	External Static Pressure(inWg)	Option Code
	0.6 < P ≤ 0.7	01B3FC-1C59FC-275A5E-370020

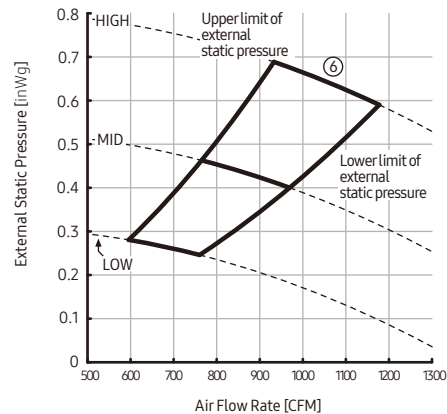

8. Temperature and air flow distribution

Duct S

CNH30HDB (AC030BNHDCH/AA)

⑦	External Static Pressure(inWg)	Option Code
	0.7 < P ≤ 0.8	01B3FC-1C5D3E-275A5E-370020

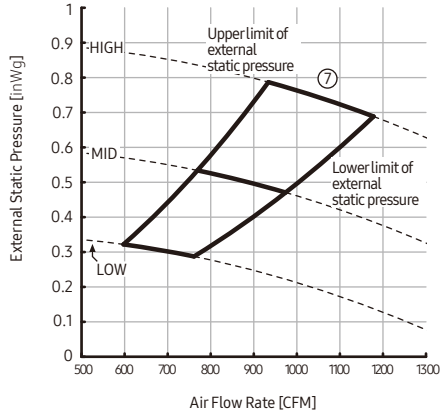

8. Temperature and air flow distribution

Duct S

CNH36HDB (AC036BNHDCH/AA)

①	External Static Pressure(inWg)	Option Code
	$2.5 \leq P \leq 5$	01B3FC-1C5439-276975-370045

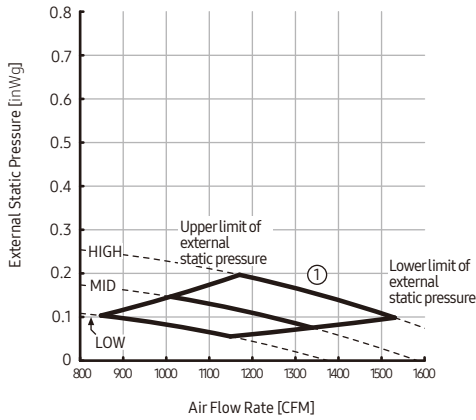

②	External Static Pressure(inWg)	Option Code
	$5 < P \leq 7.5$	01B3FC-1C548C-276975-370045

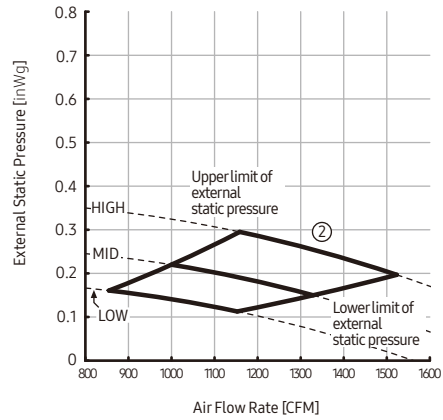

③	External Static Pressure(inWg)	Option Code
	$7.5 < P \leq 10$	01B3FC-1C54CE-276975-370045

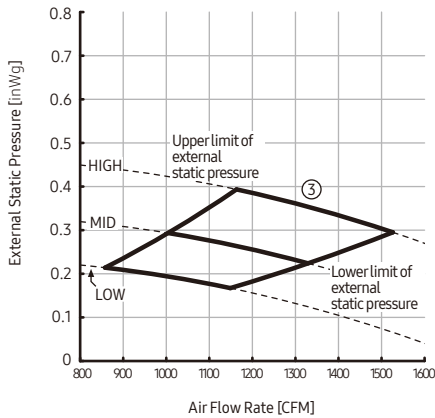

④	External Static Pressure(inWg)	Option Code
	$10 < P \leq 12.5$	01B3FC-1C55F1-276975-370045

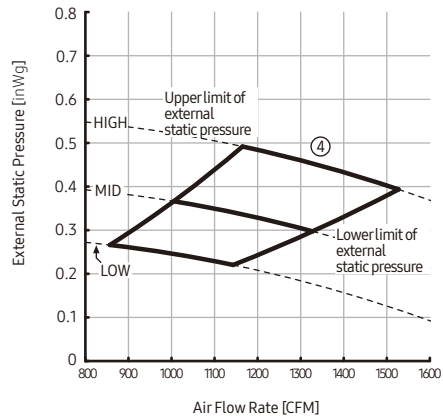

⑤	External Static Pressure(inWg)	Option Code
	$12.5 < P \leq 15$	01B3FC-1C5933-276975-370045

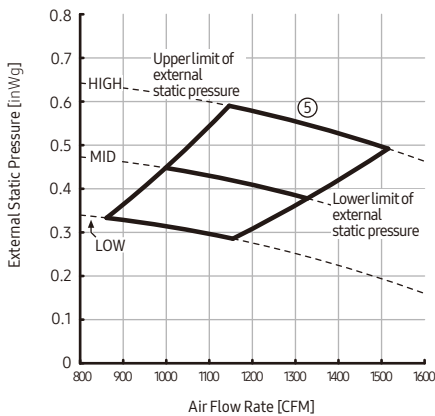

⑥	External Static Pressure(inWg)	Option Code
	$15 < P \leq 17.5$	01B3FC-1C5965-276975-370045

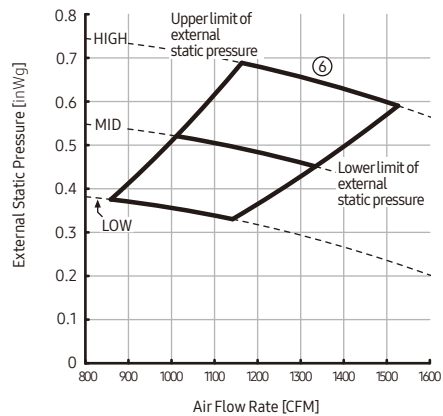

8. Temperature and air flow distribution

Duct S

CNH36HDB (AC036BNHDCH/AA)

⑦	External Static Pressure(inWg)	Option Code
	17.5 < P ≤ 20	01B3FC-1C59A6-276975-370045

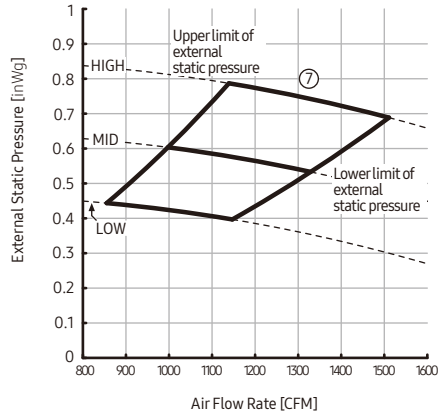

Multi-position AHU

1. Specification	41
2. Summary Table	43
3. Capacity Table	44
4. Dimensional Drawing	46
5. Electrical Wiring Diagram	47
6. Sound Data	48
7. Fan characteristics (P-Q Curve)	50

1. Specification

Multi-position AHU

Model Name		Indoor Unit		AC030BNZDCH/AA		AC036BNZDCH/AA		
US Code		Indoor Unit		CNH30ZDB		CNH36ZDB		
		Outdoor Unit		CXH30SCB		CXH36SCB		
System	Mode			-		Heat Pump		
	Performance	Capacity (Min/Std/Max)	Cooling	kW	3.81/8.79/10.55		3.96/10.55/12.31	
				Btu/h	13,000 / 30,000 / 36,000		13,500 / 36,000 / 42,000	
				US RT	1.08/2.50/3.00		1.13/3.00/3.50	
			Heating	kW	2.93/9.96/11.72		3.08/11.72/13.19	
				Btu/h	10,000 / 34,000 / 40,000		10,500 / 40,000 / 45,000	
				US RT	0.83 / 2.83 / 3.33		0.88 / 3.33 / 3.75	
	Power	Power Input (Min/Std/Max)	Cooling	kW	0.87 / 2.40 / 3.30		0.90 / 3.13 / 4.10	
			Heating		0.72 / 3.02 / 4.70		0.76 / 3.66 / 5.00	
		Current Input (Min/Std/Max)	Cooling	A	4.6 / 10.9 / 14.5		4.9 / 13.9 / 18.0	
			Heating		3.9 / 13.5 / 20.6		4.0 / 16.4 / 22.0	
		Current	MCA	A	32.1		33.2	
			MOP	A	40		40	
	Efficiency	EER2	Cooling	-	3.66		3.37	
			Cooling(US)	(Btu/h)/W	12.5		11.5	
		COP2	Heating	W/W	3.3		3.2	
		SEER2	-	-	18.5		18.7	
		HSPF2	-	-	8.6		8.6	
	Pipe Connections	Liquid Pipe	Type	Flare		Flare		
			Φ, mm(inch)	9.52 (3/8)		9.52 (3/8)		
		Gas Pipe	Type	Flare		Flare		
			Φ, mm(inch)	15.88 (5/8)		15.88 (5/8)		
		Heat Insulation		-	Both liquid and gas pipes		Both liquid and gas pipes	
		Pipe Length (ODU-IDU)	Standard	m (ft)	7.5 (24.6)		7.5 (24.6)	
				Max.	m (ft)		75 (246.0)	
	Chargeless		Elevation	m (ft)		30 (98.4)		
				m (ft)		7.5 (24.6)		
	Wiring Connections	Communication	Min.	mm ²	0.75		0.75	
Remark			-	F1,F2		F1,F2		
Refrigerant	Type		-	R410A		R410A		
	Factory Charging		kg	4.0		4.0		
Option Code	Standard		-	01E2FC-105020-275ASE-370000		01E2FC-105020-276975-370005		
	Install		-	020010-100000-200000-300000		020010-100000-200000-300000		
Indoor Unit	Power Supply			Φ,#,V,Hz	1,2,208-230,60		1,2,208-230,60	
	Heat Exchanger	Type		-	Fin & Tube		Fin & Tube	
		Material	Fin	-	Al		Al	
			Tube	-	Cu		Cu	
		Fin Treatment		-	Green Hydrophile		Green Hydrophile	
	Fan	Type		-	Sirocco		Sirocco	
		Quantity		EA	1		1	
		Air Flow Rate	H/M/L	m ³ /min	28.5/26.0/24.0		34.8/30.4/25.5	
				ft ³ /min	1006/918/848		1229/1074/901	
				l/s	475/433/400		580/507/425	
	External Static Pressure	Min/Std/Max	In Wg	0/0.58/0.98		0/0.58/0.98		
	Fan Motor	Type		-	ECM		ECM	
		Output		W x n	410 x 1		410 x 1	
	Drain	Drain Pipe		Φ, mm	FPT 3/4"		FPT 3/4"	
		Sound	Sound Pressure Level	H/M/L	dB(A)		41/38/35	
				dB(A)		59		
	Sound Power Level		dB(A)		63			
	External Dimension	Net Weight		kg(lbs)	56.0 (123.5)		56.0 (123.5)	
		Gross Weight		kg(lbs)	62.0(136.7)		62.0(136.7)	
		Net Dimensions (WxHxD)	mm		533 x 1,219 x 533		533 x 1,219 x 533	
inch			20.98 x 47.99 x 20.98		20.98 x 47.99 x 20.98			
Gross Dimensions (WxHxD)		mm		590 x 1,305 x 665		590 x 1,305 x 665		
		inch		23.23 x 51.38 x 26.18		23.23 x 51.38 x 26.18		

1. Specification

Multi-position AHU

Model Name		Indoor Unit		AC030BNZDCH/AA	AC036BNZDCH/AA
		Outdoor Unit		AC030BXSCCH/AA	AC036BXSCCH/AA
US Code		Indoor Unit		CNH30ZDB	CNH36ZDB
		Outdoor Unit		CXH30SCB	CXH36SCB
Indoor Unit	Casing	Material		Steel	Steel
	Control System	Infrared remote control		AR-EH04U	AR-EH04U
		Wired remote control		MWR-WG00UN / MWR-SH11UN	MWR-WG00UN / MWR-SH11UN
	Drain Pump	Drain Pump		-	-
		Max.lifting Height / Displacement		in / gal/h	-
	Additional Accessories	Air Filter Base (option, for vercal installation)		-	VFB-2 (MERV 8)
Heater kit (option, see NOTE 6)		-	VHK-205A VHK-210A	VHK-205A VHK-210A	
Power Supply				Φ,#,V,Hz	1,2,208-230,60
Heat Exchanger	Type		-	Fin & Tube	Fin & Tube
	Material	Fin	-	Al	Al
		Tube	-	Cu	Cu
	Fin Treatment		-	Anti-Corrosion	Anti-Corrosion
Compressor	Model		-	ATQ420D1UNT1	ATQ420D1UNT1
	Type		-	Twin BLDC	Twin BLDC
	Output		kW	3.44	3.44
	Oil	Type	-	POE	POE
		Initial Charge	cc (fl oz)	1500 (50.72)	1500 (50.72)
Fan	Type		-	Propeller	Propeller
	Discharge direction		-	Front	Front
	Quantity		EA	2	2
	Air Flow Rate	H/M/L	m ³ /min	125	125
			ft ³ /min	4,414	4,414
		l/s	2,083	2,083	
Fan Motor	Type		-	BLDC	BLDC
	Output		W x n	125 x 2	125 x 2
Sound	Sound Pressure Level	Cooling	dB(A)	49	49
		Heating	dB(A)	50	51
	Sound Power Level		dB(A)	67	69
External Dimension	Net Weight		kg(lbs)	100.0 (220.5)	100.0 (220.5)
	Gross Weight		kg(lbs)	110.0 (242.5)	110.0 (242.5)
	Net Dimensions (WxHxD)		mm	940 x 1,420 x 330	940 x 1,420 x 330
			inch	37.01 x 55.91 x 12.99	37.01 x 55.91 x 12.99
	Gross Dimensions (WxHxD)		mm	995 x 1,598 x 426	995 x 1,598 x 426
inch			39.17 x 62.91 x 16.77	39.17 x 62.91 x 16.77	
Casing	Material	Body	-	Steel	Steel
Operating Temp. Range	Cooling		°C (°F)	-20~50 (-4~122)	-20~50 (-4~122)
	Heating		°C (°F)	-25~24 (-13~75)	-25~24 (-13~75)

NOTE

- Specification may be subject to change without prior notice.
 - 1) Performances are based on the following test conditions.
 - Cooling : Indoor temperature : 80°F(26.7°C) DB, 67°F(19.4°C) WB, Outdoor temperature : 95°F(35°C) DB, 75°F(23.9°C) WB
 - Heating : Indoor temperature : 70°F(21.1°C) DB, 60°F(15.6°C) WB, Outdoor temperature : 47°F(8.3°C) DB, 43°F(6.1°C) WB
 - Equivalent refrigerant piping length 7.5m(24.6ft), Level differences : 0m(0ft)
 - 2) Select wire size based on the value of MCA
 - 3) Sound pressure level is obtained in an anechoic room.
 - Sound pressure level is a relative value, depending on the distance and acoustic environment.
 - Sound pressure level may differ depending on operation condition.
 - dBA = A-weighted sound pressure level / Reference acoustic pressure 0 dB = 20uPa
 - 4) Sound power level is an absolute value that a sound source generates.
 - dBA = A-weighted sound power level
 - Reference power : 1pW / Measured according to ISO 3741
 - 5) These products contain R410A which is fluorinated greenhouse gas.
 - 6) VHK-*05/10A: 5/10[kW] supplemental electric heat kit

2. Summary Table

Multi-position AHU

Performance Characteristics

Model Code	Net Weight (lbs)	Capacity		Fan Speed	Airflow (Cooling/Heating) (CFM)	Sound Pressure Level (dBA)	Sound Power Level (dBA)	
		Cooling (Btu/h)	Heating (Btu/h)					
CNH30ZDB + CXH30SCB (AC030BNZDCH/AA + AC030BXSCCH/AA)	123.5	Max.	36,000	40,000	High	1,006 / 1,006	41	59
		Std.	30,000	34,000	Mid	918 / 918	38	-
		Min.	13,000	10,000	Low	848 / 848	35	-
CNH36ZDB + CXH36SCB (AC036BNZDCH/AA + AC036BXSCCH/AA)	123.5	Max.	42,000	45,000	High	1,229 / 1,229	45	63
		Std.	36,000	40,000	Mid	1,074 / 1,074	42	-
		Min.	13,500	10,500	Low	901 / 901	39	-

NOTE

- Sound data is based on cooling operation.

Electric Characteristics

Model		Outdoor Unit				Input Current (Amperes)				Power Supply	
Indoor Unit	Outdoor Unit	Rated	Voltage range		Outdoor Unit		Indoor Unit	Total	MCA(A)	MOP(A)	
		Hz	Volts	Min.	Max	Cooling					Heating
CNH30ZDB (AC030BNZDCH/AA)	CXH30SCB (AC030BXSCCH/AA)	60	208 to 230	187	253	29.57	29.57	1.66	31.23	32.1	40
CNH36ZDB (AC036BNZDCH/AA)	CXH36SCB (AC036BXSCCH/AA)	60	208 to 230	187	253	29.57	29.57	1.66	31.23	33.2	40

NOTE

- MCA : Minimum circuit amperes
- MOP: Maximum Overcurrent Protective Device
- Select wire size based on the value of MCA

3. Capacity Table

Multi-position AHU

(1) CNH30ZDB (AC030BNZDCH/AA) + CXH30SCB (AC030BXSCCH/AA)

Cooling

TC : Total Capacity, SHC : Sensible Heat Capacity, PI : Power Input

Outdoor Temp. (°F, DB)	Indoor Temperature (°F, DB / WB)																				
	68 / 57			72 / 61			77 / 64			80 / 67			82 / 70			86 / 72			90 / 75		
	TC	SHC	PI	TC	SHC	PI	TC	SHC	PI	TC	SHC	PI	TC	SHC	PI	TC	SHC	PI	TC	SHC	PI
	MBH	MBH	kW	MBH	MBH	kW	MBH	MBH	kW	MBH	MBH	kW	MBH	MBH	kW	MBH	MBH	kW	MBH	MBH	kW
0	30.5	22.0	1.81	32.1	22.7	1.76	33.5	23.4	1.80	34.5	24.2	1.92	35.2	23.9	1.85	36.9	23.7	1.87	38.8	23.2	1.91
70	33.2	24.0	1.81	34.9	24.7	1.76	36.4	25.5	1.80	37.5	26.3	1.92	38.3	26.0	1.85	40.2	25.7	1.87	42.2	25.2	1.91
95	26.5	19.2	2.26	27.9	19.8	2.20	29.1	20.4	2.24	30.0	21.0	2.40	30.6	20.8	2.31	32.1	20.6	2.34	33.7	20.2	2.38
115	31.8	23.0	4.18	33.5	23.7	4.07	34.9	24.4	4.15	36.0	25.2	4.44	36.7	24.9	4.28	38.6	24.7	4.32	40.5	24.2	4.41
122	29.2	21.1	3.84	30.7	21.7	3.74	32.0	22.4	3.82	33.0	23.1	4.08	33.7	22.9	3.93	35.3	22.6	3.97	37.1	22.2	4.05

Heating

TC : Total Capacity, PI : Power Input

Outdoor Temperature (°F, DB)	Indoor Temperature (°F, DB)											
	61		64		68		70		72		75	
	TC	PI	TC	PI	TC	PI	TC	PI	TC	PI	TC	PI
	MBH	kW	MBH	kW	MBH	kW	MBH	kW	MBH	kW	MBH	kW
-13	28.0	5.00	27.7	4.95	27.5	4.90	27.2	4.85	26.9	4.80	26.7	4.75
-4	35.0	5.87	34.7	5.81	34.3	5.76	34.0	5.70	33.7	5.64	33.3	5.59
14	38.5	5.45	38.2	5.39	37.8	5.34	37.4	5.29	37.0	5.23	36.7	5.18
32	40.3	5.13	39.9	5.08	39.5	5.03	39.1	4.98	38.7	4.93	38.3	4.88
47	35.0	3.11	34.7	3.08	34.3	3.05	34.0	3.02	33.7	2.99	33.3	2.96
75.2	43.8	3.27	43.4	3.23	42.9	3.20	42.5	3.17	42.1	3.14	41.7	3.11

NOTE

- The performance table shows the average value of each conditions.

3. Capacity Table

Multi-position AHU

(2) CNH36ZDB (AC036BNZDCH/AA) + CXH36SCB (AC036BXSCCH/AA)

Cooling

TC : Total Capacity, SHC : Sensible Heat Capacity, PI : Power Input

Outdoor Temp. (°F, DB)	Indoor Temperature (°F, DB / WB)																				
	68 / 57			72 / 61			77 / 64			80 / 67			82 / 70			86 / 72			90 / 75		
	TC	SHC	PI	TC	SHC	PI	TC	SHC	PI	TC	SHC	PI	TC	SHC	PI	TC	SHC	PI	TC	SHC	PI
	MBH	MBH	kW	MBH	MBH	kW	MBH	MBH	kW	MBH	MBH	kW	MBH	MBH	kW	MBH	MBH	kW	MBH	MBH	kW
0	35.0	25.3	2.50	36.9	26.1	2.56	38.4	26.9	2.61	39.6	27.7	2.66	40.4	27.4	2.69	42.4	27.2	2.71	44.5	26.6	2.77
70	39.8	28.7	2.65	41.9	29.6	2.71	43.7	30.6	2.76	45.0	31.5	2.82	45.9	31.2	2.85	48.2	30.9	2.87	50.6	30.3	2.93
95	31.8	23.0	2.95	33.5	23.7	3.01	34.9	24.4	3.07	36.0	25.2	3.13	36.7	24.9	3.16	38.6	24.7	3.19	40.5	24.2	3.26
115	33.4	24.1	4.65	35.2	24.9	4.75	36.7	25.7	4.85	37.8	26.5	4.95	38.6	26.2	4.99	40.5	25.9	5.04	42.5	25.4	5.15
122	30.3	23.4	4.27	31.8	24.1	4.36	33.2	24.9	4.45	34.2	25.7	4.54	34.9	25.4	4.58	36.6	25.1	4.63	38.5	24.6	4.72

Heating

TC : Total Capacity, PI : Power Input

Outdoor Temperature (°F, DB)	Indoor Temperature (°F, DB)											
	61		64		68		70		72		75	
	TC	PI	TC	PI	TC	PI	TC	PI	TC	PI	TC	PI
	MBH	kW	MBH	kW	MBH	kW	MBH	kW	MBH	kW	MBH	kW
-13	30.9	5.05	30.6	5.00	30.3	4.95	30.0	4.90	29.7	4.85	29.4	4.80
-4	41.2	5.98	40.8	5.92	40.4	5.86	40.0	5.80	39.6	5.74	39.2	5.69
14	43.3	5.84	42.8	5.79	42.4	5.73	42.0	5.67	41.6	5.62	41.2	5.56
32	47.4	5.66	46.9	5.60	46.5	5.54	46.0	5.49	45.5	5.44	45.1	5.38
47	41.2	3.77	40.8	3.73	40.4	3.70	40.0	3.66	39.6	3.62	39.2	3.59
75.2	53.6	4.34	53.0	4.29	52.5	4.25	52.0	4.21	51.5	4.17	51.0	4.13

NOTE

- The performance table shows the average value of each conditions.

4. Dimensional Drawing

Multi-position AHU

CNH30ZD*(AC030*NZDCH/AA), CNH36ZD*(AC036*NZDCH/AA)

Units : mm [inches]

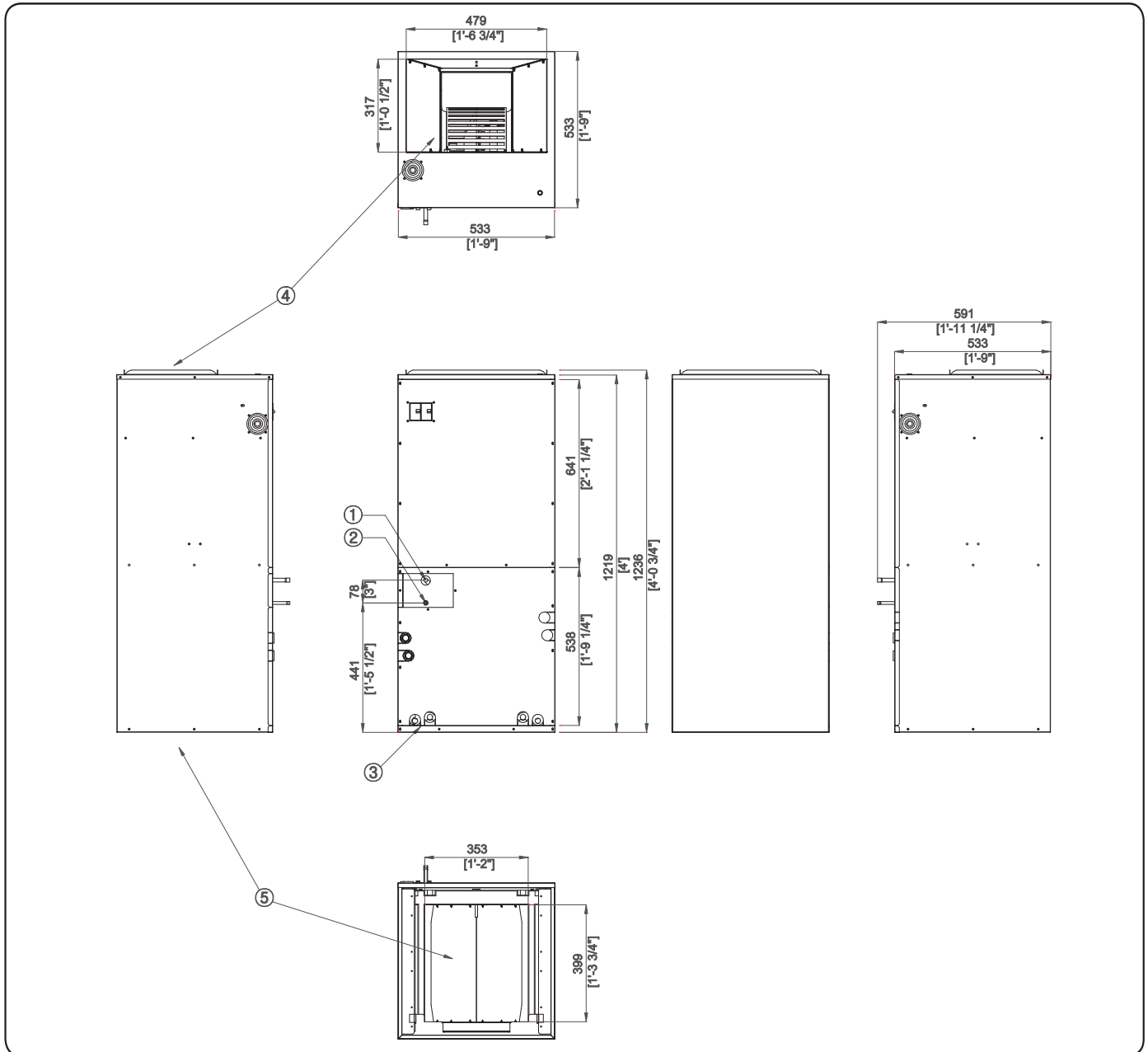

No.	Name	Description
1	Gas pipe connection	Φ15.88(5/8)
2	Liquid pipe connection	Φ9.52(3/8)
3	Drain pipe connection	FPT 3/4"
4	Air outlet	
5	Air intake	

5. Electrical Wiring Diagram

Multi-position AHU

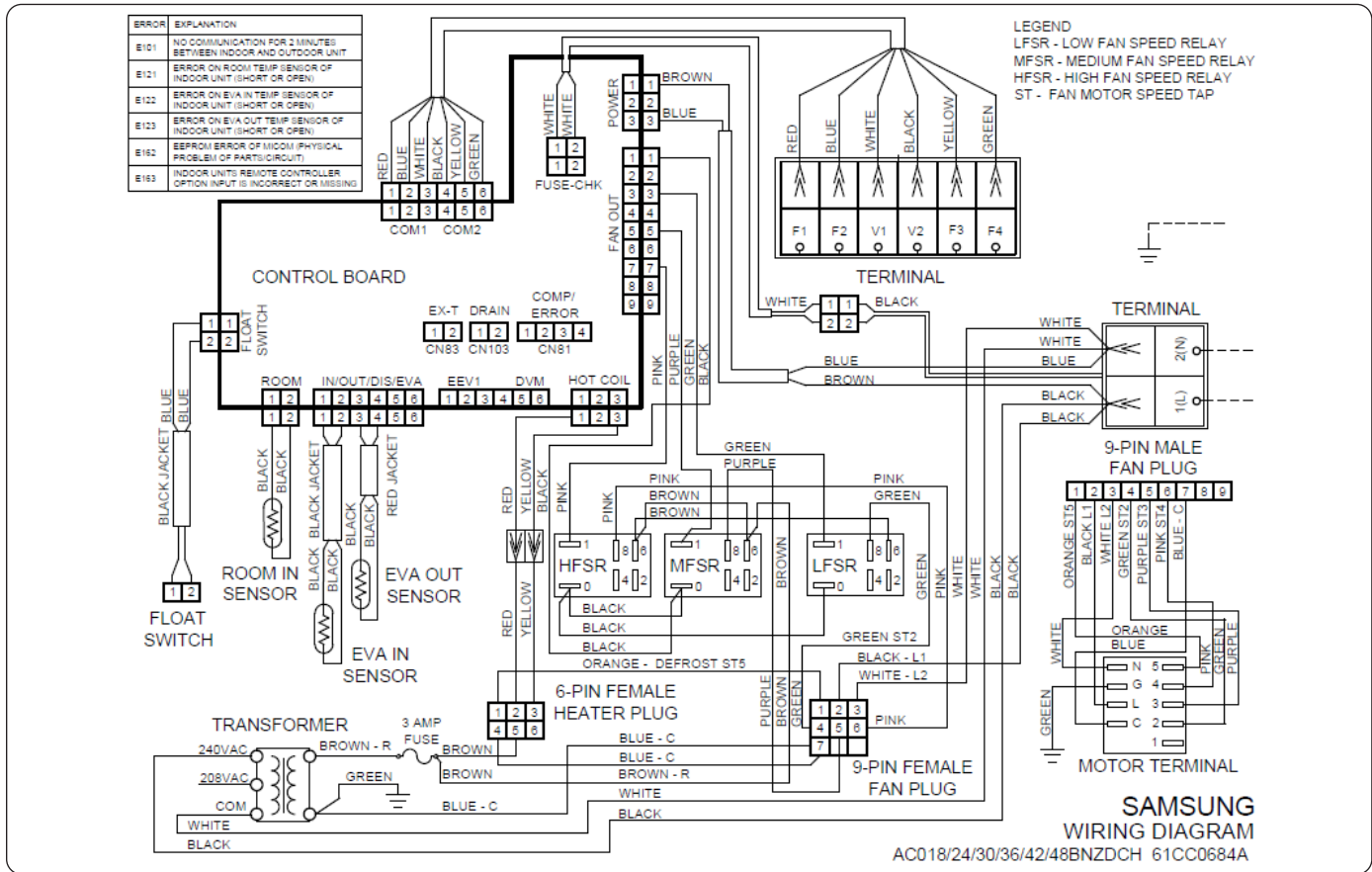

CONTROL BOARD	Printed circuit board(MAIN)	MFSR	MEDIUM FAN SPEED RELAY	EVA-IN(10K)	Thermistor EVA IN
EX-T	EXTERNAL CONTROL	HFSR	HIGH FAN SPEED RELAY	EVA-OUT(10K)	Thermistor EVA OUT
LFSR	LOW FAN SPEED RELAY	ROOM(10K)	Thermistor ROOM	DISCHARGE(10K)	Thermistor DISCHARGE

NOTE

- This wiring diagram applies only to the indoor unit.
- Colors BLK : black, BRN : brown, SKY-BLU : sky-blue, GRN/YEL : green/yellow, RED : red, YEL : yellow, ORG : orange, BLU : blue, WHT:white
- For connection wiring indoor-outdoor transmission F1-F2, indoor-wired remotecontroller transmission F3-F4, refer to the installation manual
- Protective earth(screw)

6. Sound Data

Multi-position AHU

Sound Pressure level

Unit: dB(A)

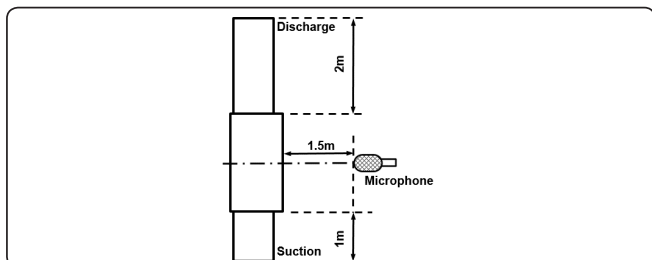

Model	High	Mid	Low
CNH30ZDB (AC030BNZDCH/AA)	41	38	35
CNH36ZDB (AC036BNZDCH/AA)	45	42	39

- NC Curve

1) CNH30ZDB (AC030BNZDCH/AA)

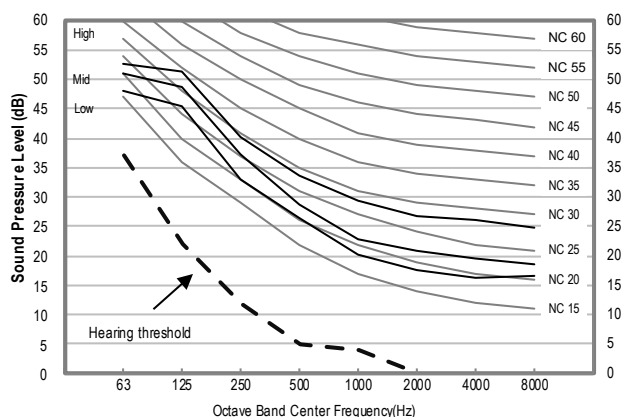

2) CNH36ZDB (AC036BNZDCH/AA)

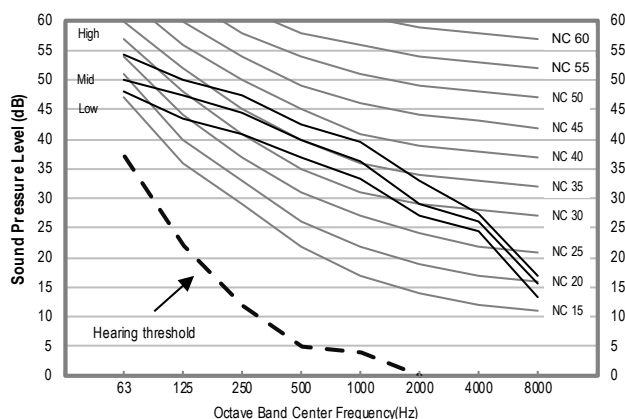

NOTE

- Specifications may be subject to change without prior notice.
 - Sound pressure level is obtained in an anechoic room.
 - Sound pressure level is a relative value, depending on the distance and acoustic environment.
 - Sound pressure level may differ depending on operation condition.
 - dBA = A weighted sound pressure level
 - Reference acoustic pressure 0 dB = 20μPa

6. Sound Data

Multi-position AHU

Sound Power level

NOTE

Unit: dB(A)

- Specifications may be subject to change without prior notice
 - Sound power level is an absolute value that a sound source generates.
 - dBA = A-weighted sound power level.
 - Reference power : 1pW.
 - Measured according to ISO 3741.

Model	Cooling
CNH30ZDB (AC030BNZDCH/AA)	59
CNH36ZDB (AC036BNZDCH/AA)	63

• NC Curve

1) CNH30ZDB (AC030BNZDCH/AA)

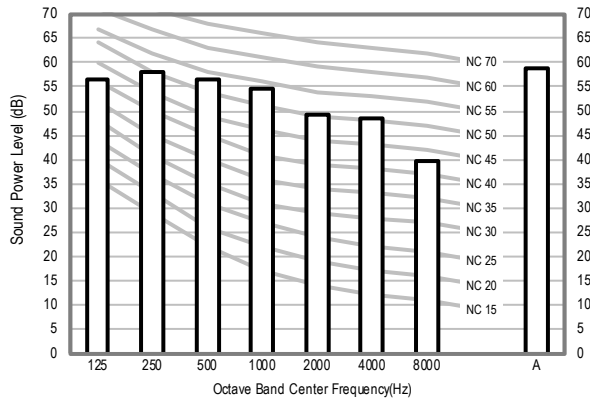

2) CNH36ZDB (AC036BNZDCH/AA)

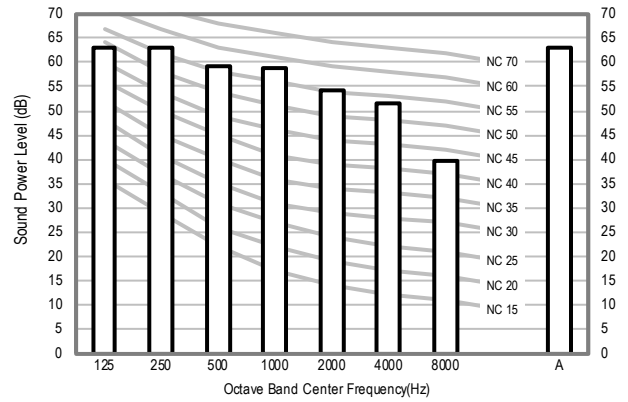

7. Fan characteristics (P-Q Curve)

Multi-position AHU

CNH30ZDB (AC030BNZDCH/AA)

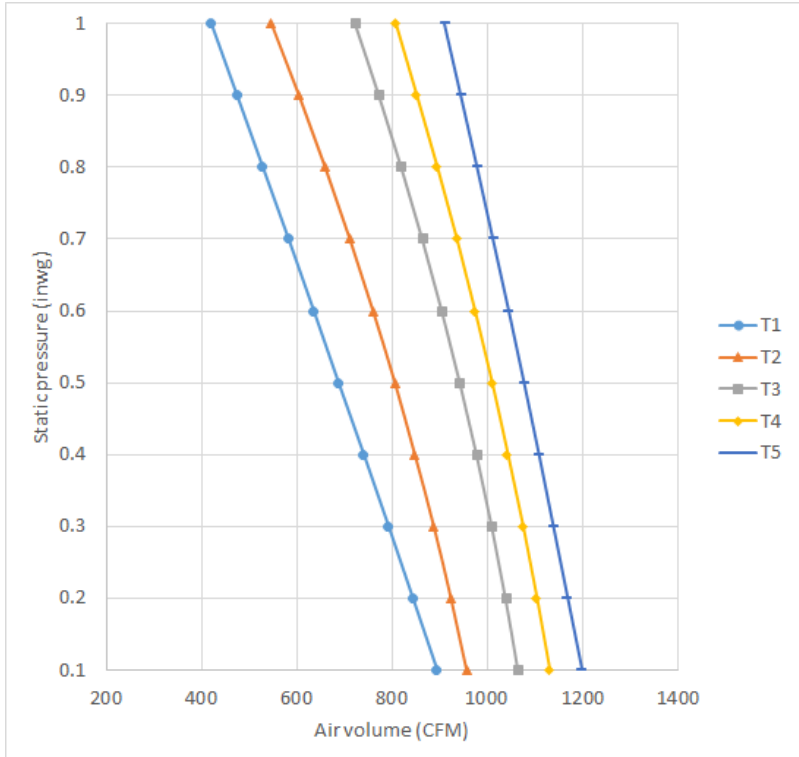

CNH36ZDB (AC036BNZDCH/AA)

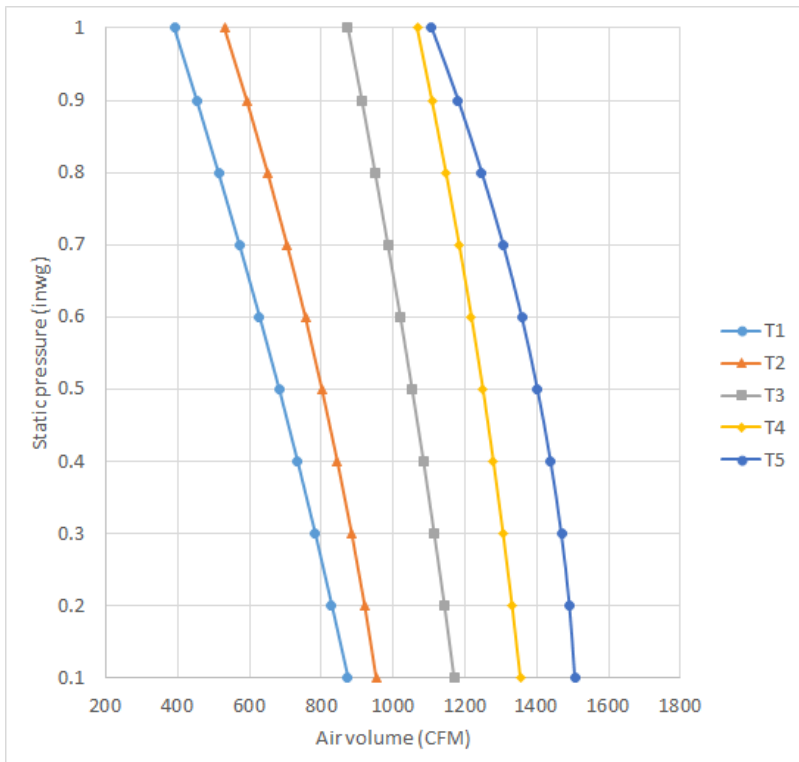

T1	Low speed tap
T2	Medium-low speed tap
T3	Medium speed tap
T4	Medium-high speed tap
T5	High speed tap

Outdoor Units

1. Summary Table	52
2. Dimensional Drawing	53
3. Center of Gravity	54
4. Electrical Wiring Diagram	55
5. Sound Data	56
6. Capacity Correction	58
7. Operation Range	59
8. Piping Diagram	60

1. Summary Table

Outdoor Units

Performance Characteristics

Capacity (Btu/h)	Model Code	Net Size (WxHxD inch)	Net Weight (lbs)	Airflow (CFM)	Sound Pressure Level (dBA)		Sound Power Level (dBA)
					Cooling	Heating	
30,000	CXH30SCB(AC030BXSCCH/AA)	37.01 x 55.91 x 12.99	220.5	4,414	49	50	67
36,000	CXH36SCB(AC036BXSCCH/AA)	37.01 x 55.91 x 12.99	220.5	4,414	49	51	69

NOTE

- Sound power level is based on cooling operation.

2. Dimensional Drawing

Outdoor Units

CXH30SCB (AC030BXSCCH/AA), CXH36SCB (AC036BXSCCH/AA)

Units : mm [inches]

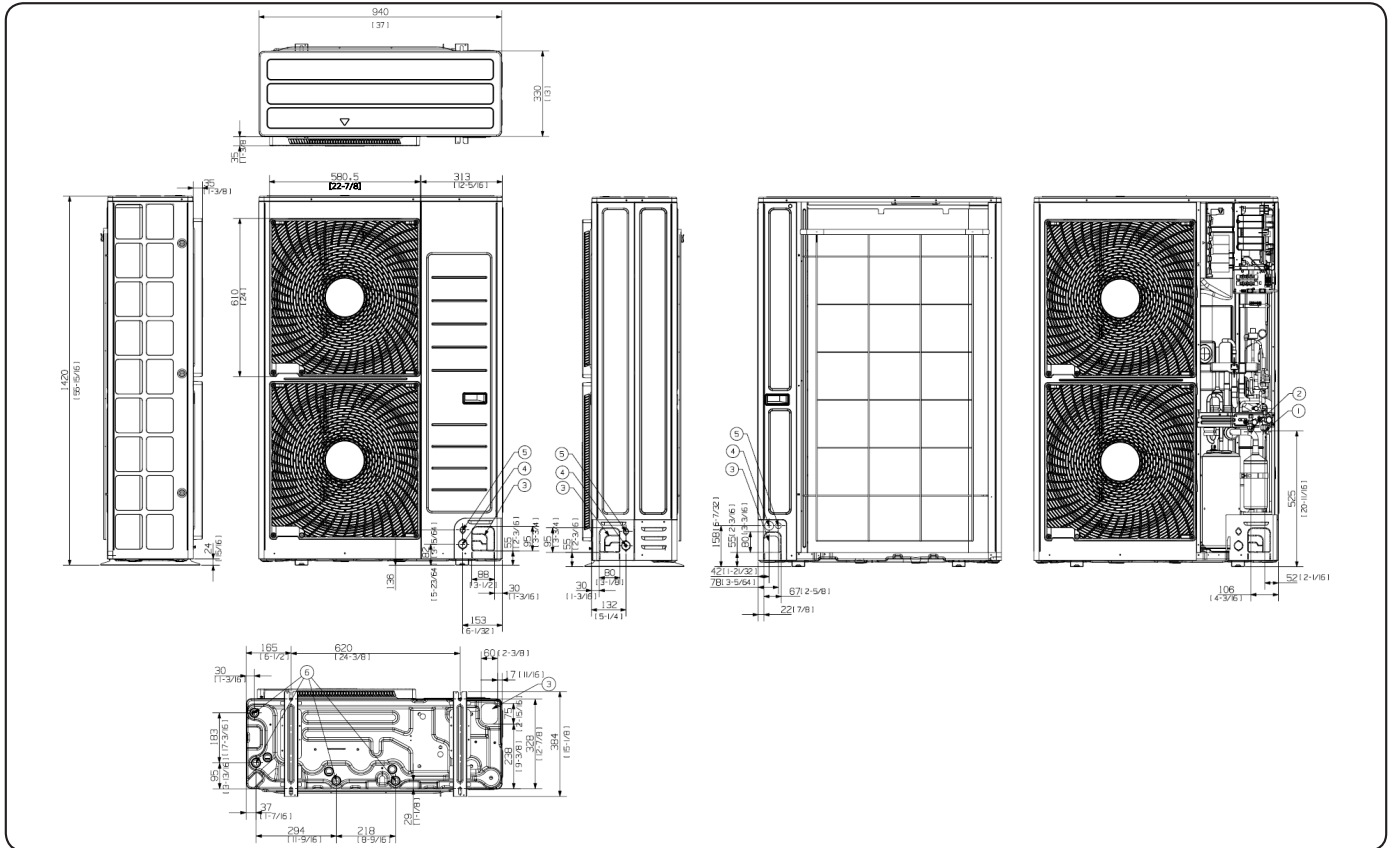

No.	Name	Description
1	Refrigerant liquid pipe	Φ 9.52mm(3/8")
2	Refrigerant gas pipe	Φ 15.88mm(5/8")
3	Piping intake knockout hole	Front / Side / Rear / Bottom
4	Power wiring conduit	Front / Side / Rear , Φ 34mm(1-3/8")
5	Communication wiring conduit	Front / Side / Rear , Φ 22mm(7/8")
6	Drain Hole	Connect with the provided drain plug

3. Center of Gravity

Outdoor Units

CXH30SCB (AC030BXSCCH/AA), CXH36SCB (AC036BXSCCH/AA)

Units : mm [inches]

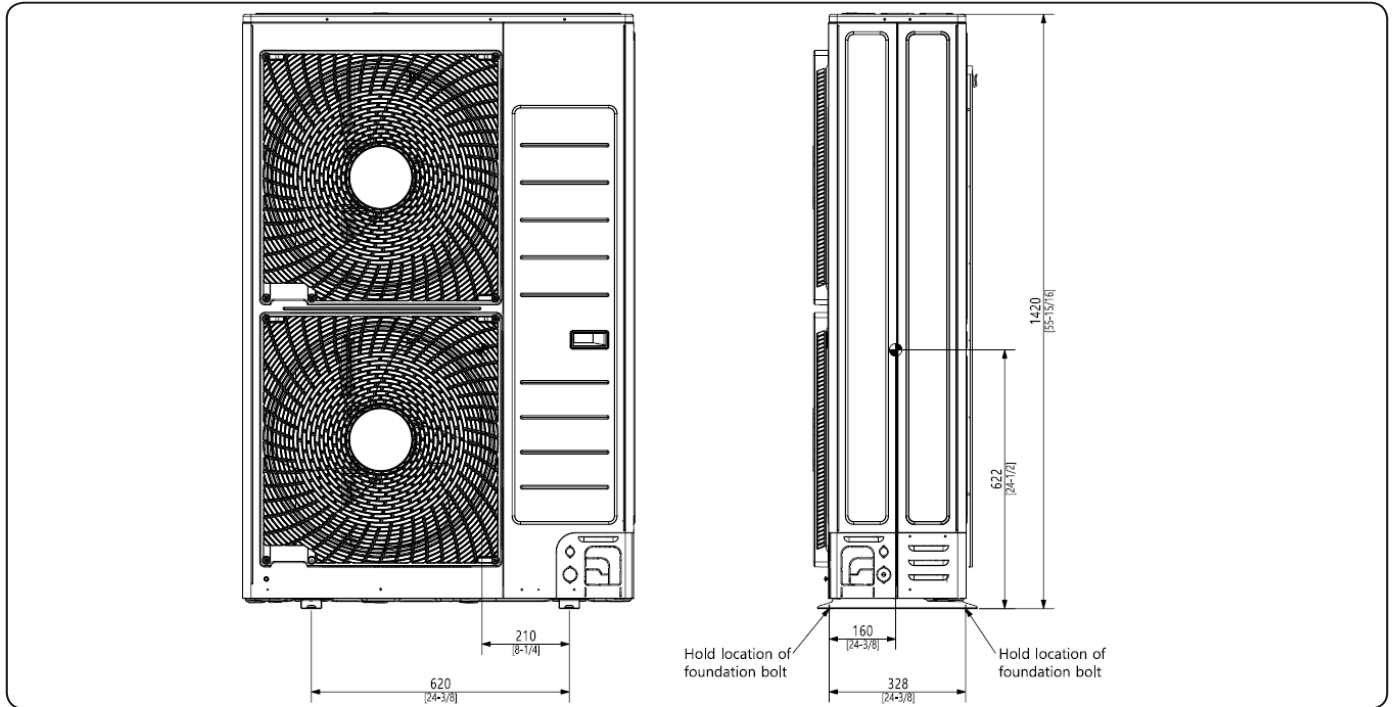

4. Electrical Wiring Diagram

Outdoor Units

CXH30SCB(AC030BXSCCH/AA),CXH36SCB(AC036BXSCCH/AA)

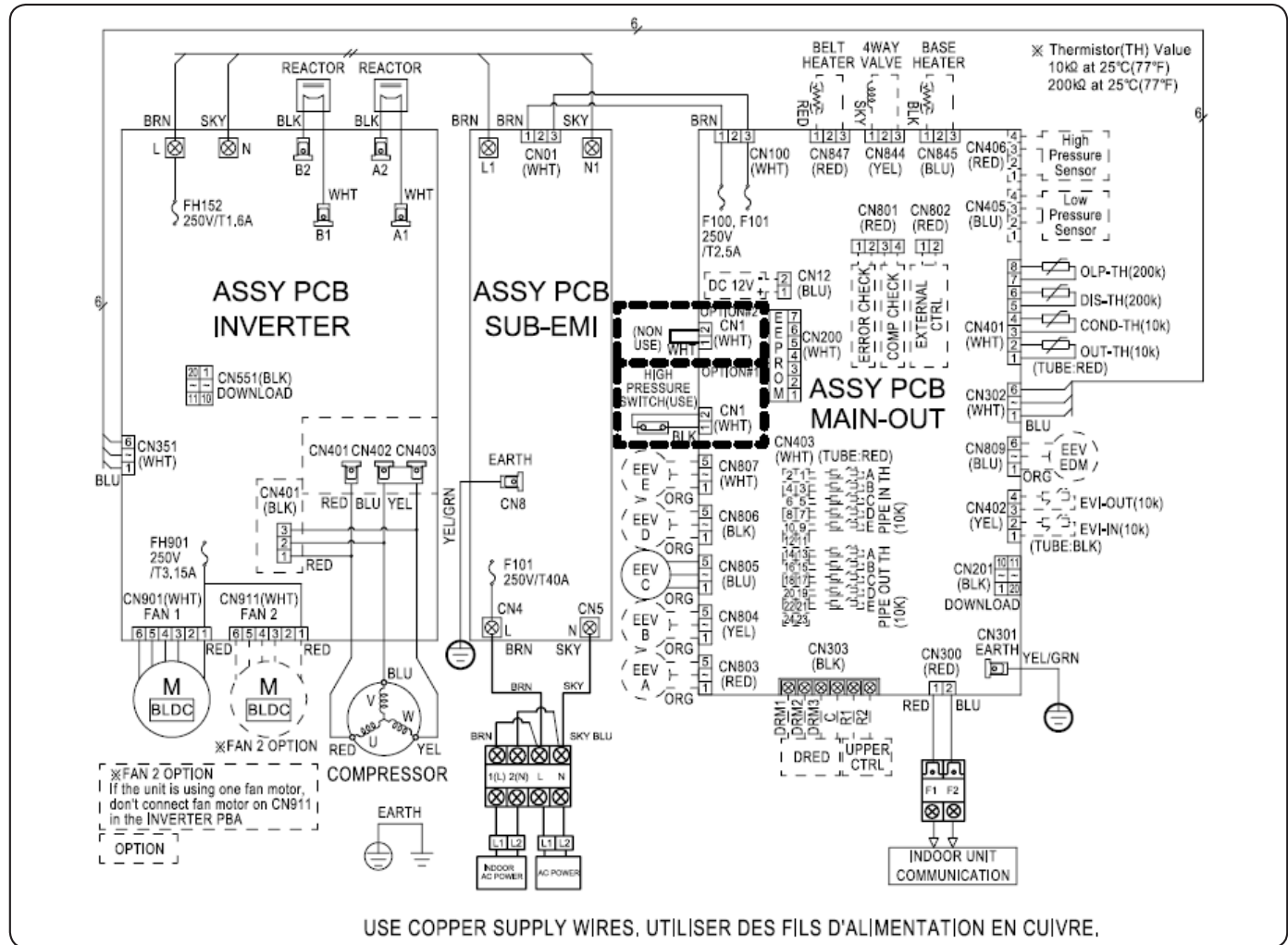

MAIN PCB	Printed circuit board(MAIN)	EEV	Electronic Expansion Valve
INVERTER PCB	Printed circuit board(INVERTER)	M-BLDC	BLDC Motor
EMI	Printed circuit board(EMI)	DIS-TH(200K)	Thermistor DISCHARGE
OLT-TH(200K)	Thermistor OLP	COND-TH(10K)	Thermistor CONDENSOR
OUT-TH(10K)	Thermistor AMBIENT		

NOTE

- This wiring diagram applies only to the outdoor unit.
- Colors blk: black, red: red, blu: blue, wht: white, yel: yellow, brn: brown, sky: skyblue
- When operating, don't shortcircuit the protection device (High Pressure switch)
- For connection wiring indoor-outdoor transmission F1-F2, outdoor-outdoor transmission OF1-OF2, refer to the installation manual.
- ⊕ Protective earth(screw), □□□□ : connector, $\frac{N}{\text{---}}$: The wire quantity

5. Sound Data

Outdoor Units

Sound Pressure level

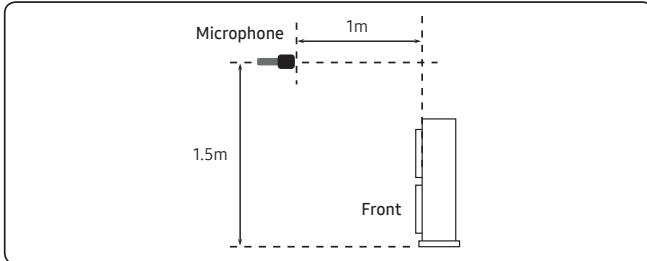

Unit: dB(A)

Model	Cooling	Heating
CXH30SCB (AC030BXSCCH/AA)	49	50
CXH36SCB (AC036BXSCCH/AA)	49	51

- NC Curve

1) CXH30SCB (AC030BXSCCH/AA)

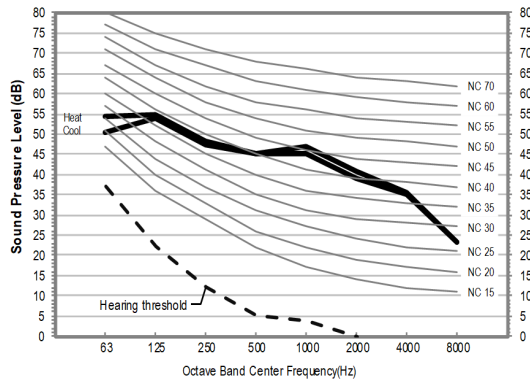

2) CXH36SCB (AC036BXSCCH/AA)

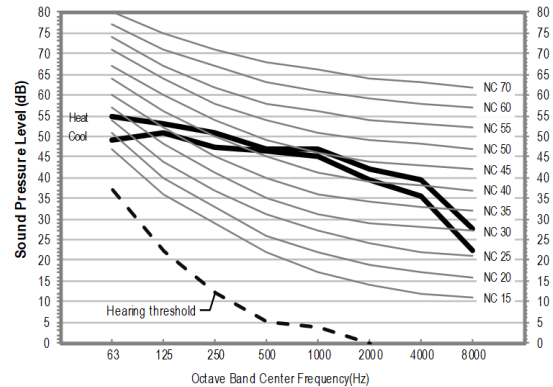

NOTE

- Specifications may be subject to change without prior notice.
 - Sound pressure level is obtained in an anechoic room.
 - Sound pressure level is a relative value, depending on the distance and acoustic environment.
 - Sound pressure level may differ depending on operation condition.
 - dBA = A weighted sound pressure level
 - Reference acoustic pressure 0 dB = 20μPa

5. Sound Data

Outdoor Units

Sound Power level

NOTE

- Specifications may be subject to change without prior notice
 - Sound power level is an absolute value that a sound source generates.
 - dBA = A-weighted sound power level.
 - Reference power : 1pW.
 - Measured according to ISO 3741.

Unit: dB(A)

Model	Cooling
CXH30SCB (AC030BXSCCH/AA)	67
CXH36SCB (AC036BXSCCH/AA)	69

- NC Curve

1) CXH30SCB (AC030BXSCCH/AA)

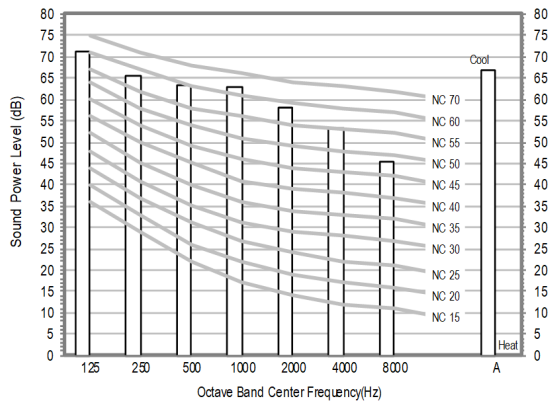

2) CXH36SCB (AC036BXSCCH/AA)

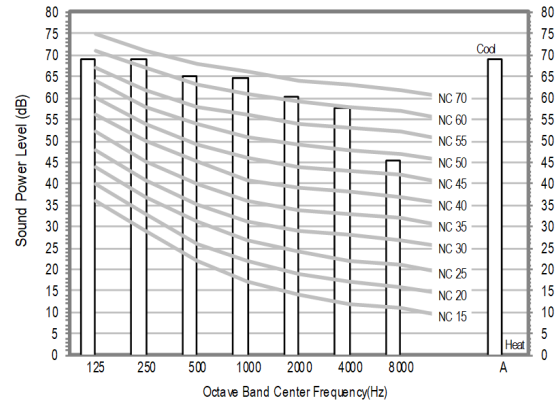

6. Capacity Correction

Outdoor Units

CNH30*D*(AC030*N*DCH/AA)+CXH30SCB(AC030BXSCCH/AA)
 CNH36*D*(AC036*N*DCH/AA)+CXH36SCB(AC036BXSCCH/AA)

Cooling



		Pipe Length (ft)														
		24.6	32.8	49.2	65.6	82.0	98.4	114.8	131.2	147.6	164.0	180.4	196.9	213.3	229.7	246.1
Level Difference (ft)	98.4	-	-	-	-	-	0.96	0.95	0.94	0.93	0.92	0.91	0.91	0.90	0.89	0.88
	82.0	-	-	-	-	0.97	0.96	0.95	0.94	0.93	0.92	0.91	0.91	0.90	0.89	0.88
	65.6	-	-	-	0.97	0.97	0.96	0.95	0.94	0.93	0.92	0.91	0.91	0.90	0.89	0.88
	49.2	-	-	0.98	0.97	0.97	0.96	0.95	0.94	0.93	0.92	0.91	0.91	0.90	0.89	0.88
	32.8	-	0.99	0.98	0.97	0.97	0.96	0.95	0.94	0.93	0.92	0.91	0.91	0.90	0.89	0.88
	16.4	1.00	0.99	0.98	0.97	0.97	0.96	0.95	0.94	0.93	0.92	0.91	0.91	0.90	0.89	0.88
	0.0	1.00	0.99	0.98	0.97	0.97	0.96	0.95	0.94	0.93	0.92	0.91	0.91	0.90	0.89	0.88
	-16.4	1.00	0.99	0.98	0.97	0.96	0.95	0.95	0.94	0.93	0.92	0.91	0.90	0.89	0.88	0.87
	-32.8	-	0.98	0.98	0.97	0.96	0.95	0.94	0.93	0.93	0.92	0.91	0.90	0.89	0.87	0.85
	-49.2	-	-	0.97	0.97	0.96	0.95	0.94	0.93	0.92	0.91	0.90	0.89	0.88	0.86	0.84
	-65.6	-	-	-	0.96	0.95	0.95	0.94	0.93	0.92	0.91	0.90	0.89	0.88	0.86	0.83
	-82.0	-	-	-	-	0.95	0.94	0.93	0.93	0.92	0.91	0.90	0.88	0.87	0.85	0.81
	-98.4	-	-	-	-	-	0.94	0.93	0.92	0.91	0.90	0.89	0.88	0.86	0.84	0.80

Heating



		Pipe Length (m)														
		24.6	32.8	49.2	65.6	82.0	98.4	114.8	131.2	147.6	164.0	180.4	196.9	213.3	229.7	246.1
Level Difference (ft)	98.4	-	-	-	-	-	0.96	0.95	0.94	0.93	0.92	0.91	0.91	0.90	0.89	0.88
	82.0	-	-	-	-	0.97	0.96	0.95	0.94	0.93	0.92	0.91	0.91	0.90	0.89	0.88
	65.6	-	-	-	0.97	0.97	0.96	0.95	0.94	0.93	0.92	0.91	0.91	0.90	0.89	0.88
	49.2	-	-	0.98	0.97	0.97	0.96	0.95	0.94	0.93	0.92	0.91	0.91	0.90	0.89	0.88
	32.8	-	0.99	0.98	0.97	0.97	0.96	0.95	0.94	0.93	0.92	0.91	0.91	0.90	0.89	0.88
	16.4	1.00	0.99	0.98	0.97	0.97	0.96	0.95	0.94	0.93	0.92	0.91	0.91	0.90	0.89	0.88
	0.0	1.00	0.99	0.98	0.97	0.97	0.96	0.95	0.94	0.93	0.92	0.91	0.91	0.90	0.89	0.88
	-16.4	1.00	0.99	0.98	0.97	0.97	0.96	0.95	0.94	0.93	0.92	0.91	0.91	0.90	0.89	0.88
	-32.8	-	0.99	0.98	0.97	0.97	0.96	0.95	0.94	0.93	0.92	0.91	0.91	0.90	0.89	0.88
	-49.2	-	-	0.98	0.97	0.97	0.96	0.95	0.94	0.93	0.92	0.91	0.91	0.90	0.89	0.88
	-65.6	-	-	-	0.97	0.97	0.96	0.95	0.94	0.93	0.92	0.91	0.91	0.90	0.89	0.88
	-82.0	-	-	-	-	0.97	0.96	0.95	0.94	0.93	0.92	0.91	0.91	0.90	0.89	0.88
	-98.4	-	-	-	-	-	0.96	0.95	0.94	0.93	0.92	0.91	0.91	0.90	0.89	0.88

7. Operation Range

Outdoor Units

CXH**SCB (AC***BXSCCH/AA)

Mode	Indoor temperature	Outdoor temperature	Indoor humidity
Cooling	18°C to 32°C (64°F to 90°F)	-20°C to 50°C (-4°F to 122°F)	80% or less
Drying	18°C to 32°C (64°F to 90°F)	-20°C to 50°C (-4°F to 122°F)	80% or less
Heating	30°C(86°F) or less	-25°C to 24°C (-13°F to 75°F)	-

NOTE

- The assumed installation conditions are follows
 - The pipe length(including elbow) is 7.5m(24.6ft).
 - The level difference is 0 m.

8. Piping Diagram

Outdoor Units

CNH304DB(AC030BN4DCH/AA)+CXH30SCB(AC030BXSCCH/AA)
CNH364DB(AC036BN4DCH/AA)+CXH36SCB(AC036BXSCCH/AA)

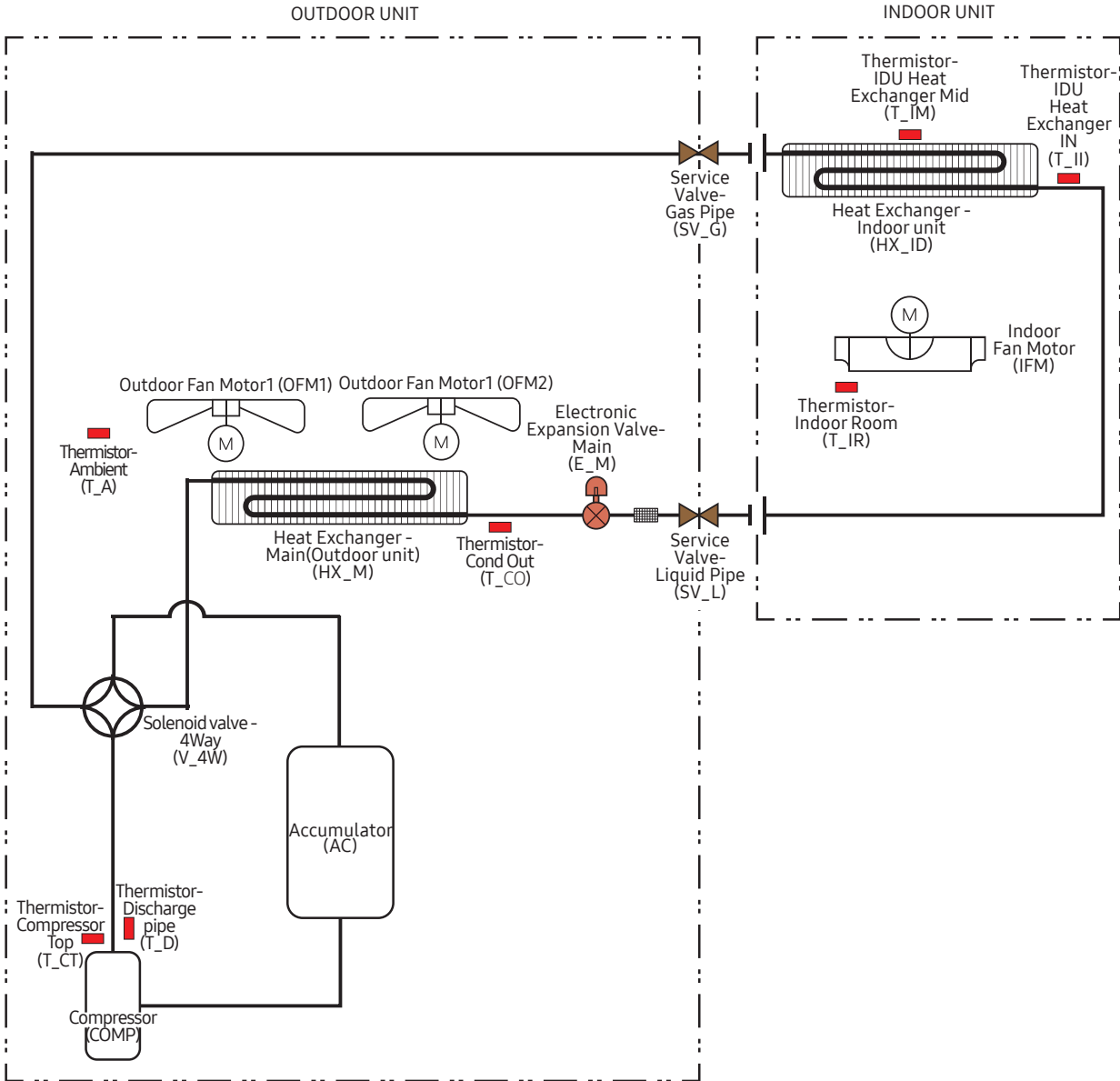

8. Piping Diagram

Outdoor Units

CNH30HDB(AC030BNHDCH/AA)+CXH30SCB(AC030BXSCCH/AA)
CNH36HDB(AC036BNHDCH/AA)+CXH36SCB(AC036BXSCCH/AA)
CNH30HDK(AC030KNHDCH/AA)+CXH30SCB(AC030BXSCCH/AA)
CNH36HDK(AC036KNHDCH/AA)+CXH36SCB(AC036BXSCCH/AA)

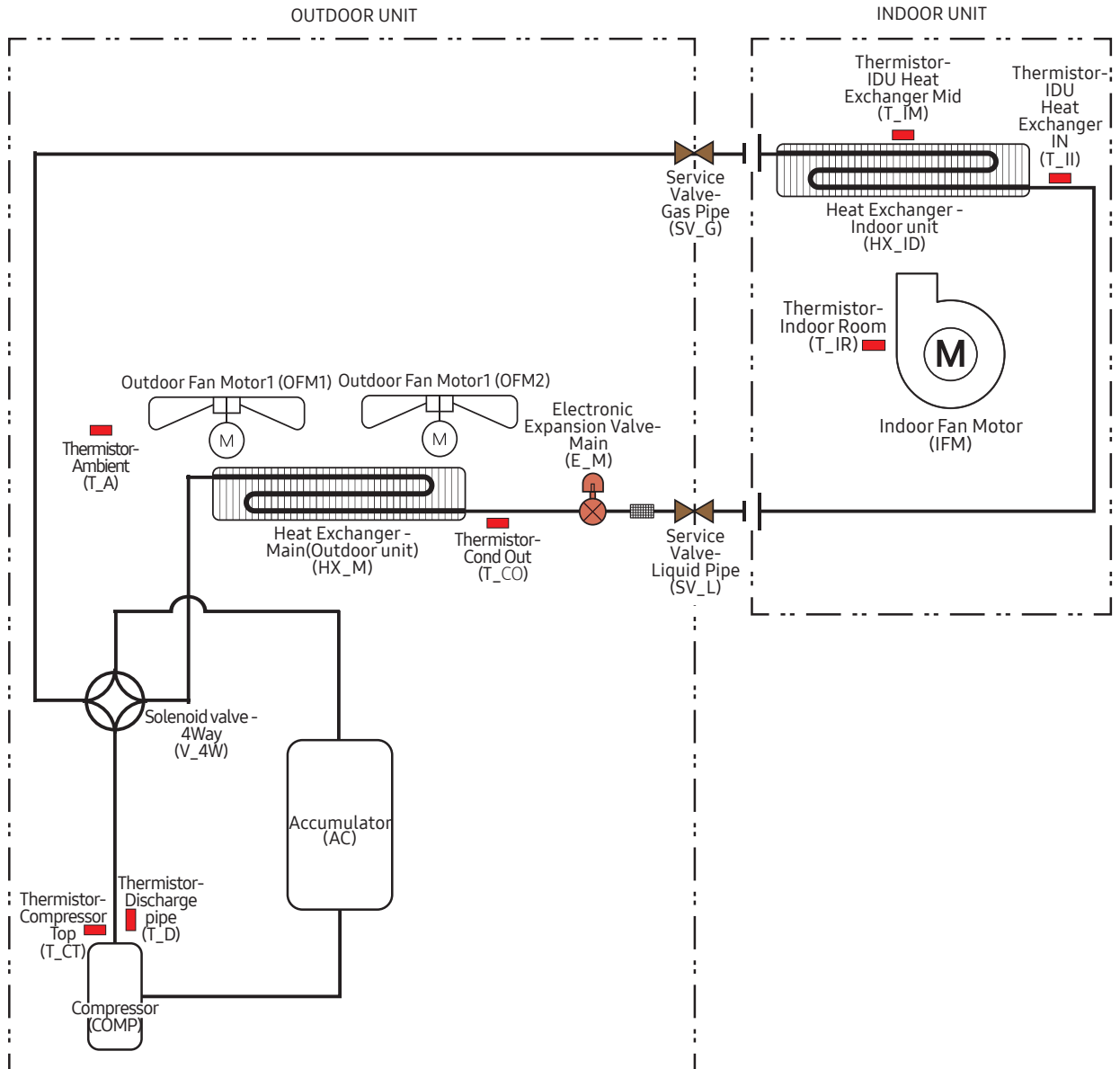

Installation

4 Way Cassette

Choosing the installation location

Installation location requirements

- There must be no obstacles near the air inlet and outlet.
- Install the indoor unit on a ceiling that can support its weight.
- Maintain sufficient clearance around the indoor unit.
- Before installing the indoor unit, be sure to check whether the chosen location is well-drained.
- The indoor unit must be installed such that it is beyond public access and is not touchable by users.
- A vibration-resistant location that is not inclined (If the indoor unit is installed on a structure that is not sturdy, it may fall and get damaged or cause injury.)
- Where it is not exposed to direct sunshine.
- Where the air filter can be removed and cleaned easily.

CAUTION

- As a rule, the unit cannot be installed at a height of less than 8.2ft (2.5m).
- If you install a cassette type indoor unit on the ceiling when temperature is over 80.6°F (27°C) and humidity is over 80%, you must apply an extra 0.39inch (10mm) thick polyethylene insulation or a similar type of insulation to the body of the indoor unit.

Do not install the air conditioner in following places.

- A place with exposure to mineral oil, oil vapour or cooking area where there is spray (If oil adheres to the heat exchanger, performance degradation, spray or condensation scattering may occur. If oil adheres to a plastic component, the component may deform or get damaged. Such issues may result in a system failure or refrigerant leak.)
- The place where corrosive gas such as sulphuric acid gas generates from the vent pipe or air outlet.
- The copper pipe or connection pipe may corrode and refrigerant may leak.
- The place where there is a machine that generates electromagnetic waves. The air conditioner may not operate normally due to control system.
- The place where there is a danger of existing combustible gas, carbon fibre or flammable dust.
- The place where thinner or gasoline is handled. Gas may leak and it may cause fire.

Spacing requirements

4 way Cassette

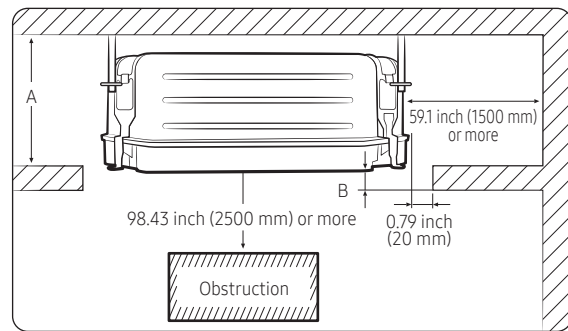

Unit: inch(mm)

	AC030BN4DCH AC036BN4DCH
A	13.19 (335)
B	0.67 (17)

Installation

4 Way Cassette

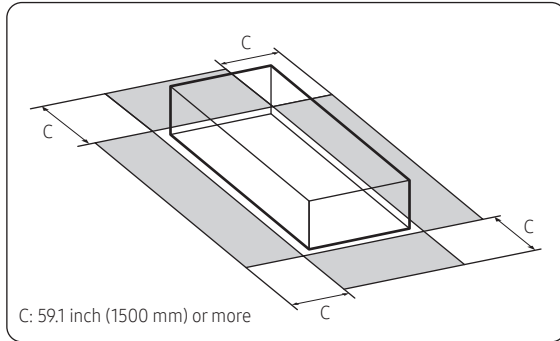

⚠ CAUTION

- The indoor unit must be installed according to the specified distances in order to permit accessibility from each side, to guarantee correct operation, maintenance, and repair of the unit. The components of the indoor unit must be reachable and removable under safe conditions for people and the unit.
- Do not carry the unit by holding the refrigerant or drain pipes to avoid product damage.
- Carry the unit by holding the hanger plates located on the corners of the unit.

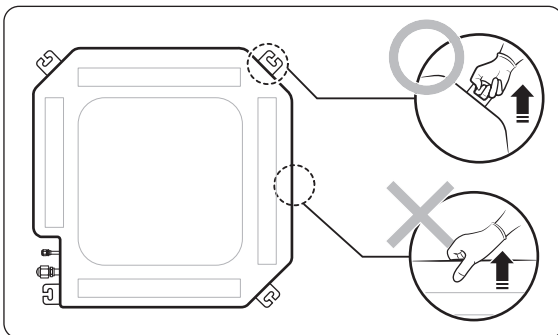

Optional: Insulating the body of the indoor unit

If you install a cassette type indoor unit on the ceiling when temperature is over 80.6 °F (27 °C) and humidity is over 80%, you must apply an extra 10 mm thick polyethylene insulation or a similar type of insulation to the body of the indoor unit.

Cut away the part where pipes are pulled out for the insulating work.

4 way Cassette

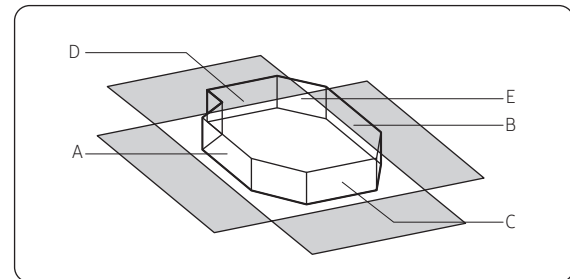

Insulate the end of the pipe and some curved area by using separate insulator.

📄 NOTE

- A: Reference for the outer circumference of the unit (When insulating the body of the indoor unit, use A as the reference for its outer circumference.)

4 way Cassette

Indoor unit		A	B	C	D	E
4 way Cassette	AC030BN4DCH	35.83X9.25	37.00X9.25	24.02X9.25	25.59X9.25	34.25X34.25
	AC036BN4DCH	(910X235)	(940X235)	(610X235)	(650X235)	(870X870)

Installation

4 Way Cassette

Installing the indoor unit

When deciding on the location of the air conditioner the following restrictions must be taken into account.

- 1 Place the pattern sheet on the ceiling at the location where you want to install the indoor unit.

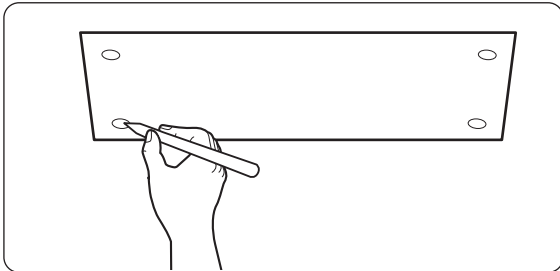

NOTE

- Since the diagram is made of paper, it may shrink or stretch slightly due to temperature or humidity. For this reason, before drilling the holes, be sure to maintain the correct dimensions between the markings.
- 2 Insert bolt anchors, use existing ceiling supports or construct a suitable support as shown in figure.

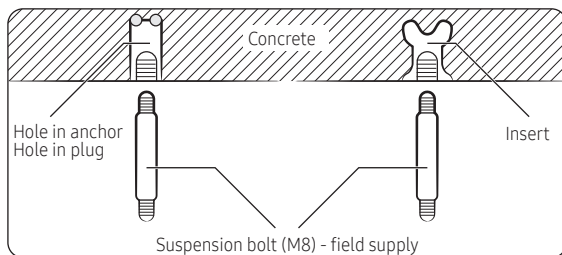

- 3 Install the suspension bolts, depending on the ceiling type.

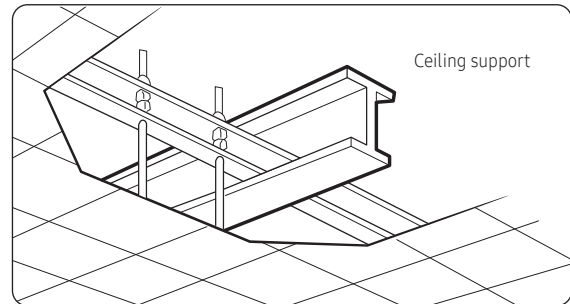

CAUTION

- Make sure that the ceiling is strong enough to support the weight of the indoor unit. Before hanging the unit, test the strength of each attached suspension bolt.
 - If the length of the suspension bolt is more than 4.92ft(1.5m), vibration prevention is recommended. If this is not possible, create an opening on the false ceiling in order to be able to use it to perform the required operations on the indoor unit.
- 4 Screw eight nuts and washers to the suspension bolts, making space for hanging the indoor unit.

CAUTION

- You must install all of the suspension rods.
- It is important to leave sufficient space in the false ceiling to allow access for maintenance or repairs to the drainage pipe connection, the refrigerant pipe connection, or to remove the unit if necessary.

Installation

4 Way Cassette

- 5 Hang the indoor unit to the suspension bolts between two nuts. Screw the nuts to suspend the unit.

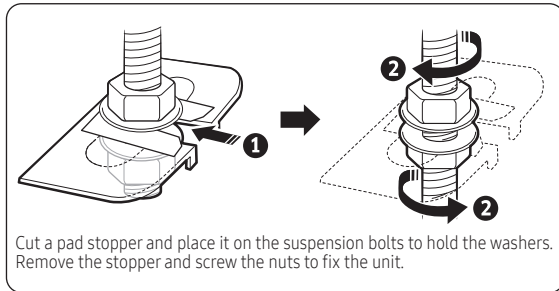

- 6 Check the level of the indoor unit by using a Level.
 - A tilt of the indoor unit may cause malfunction of a built-in float switch and water leaks.

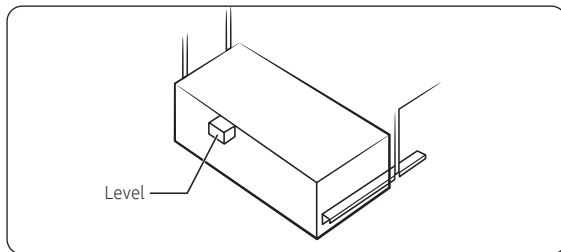

- 7 Adjust the unit to the appropriate position, taking into account the installation area for the front panel.
 - Place the pattern sheet on the indoor unit.
 - Adjust the space between the ceiling and the indoor unit by using a Tape measure.
 - Fix the indoor unit securely after adjusting the level of the unit by using a level.
 - Remove the pattern sheet and install the front panel.

When the installation template is made of paper

4 way Cassette

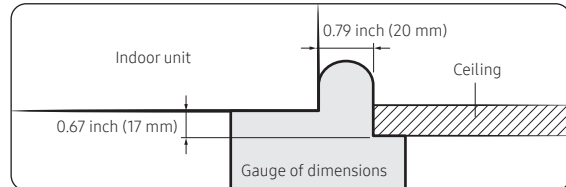

Installing the drain hose and drain pipe

- 1 Push the supplied drain hose as far as possible over the drain socket.
- 2 Tighten the metal clamp as shown in the picture.

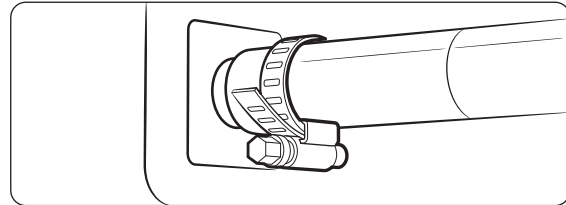

- 3 Wrap the supplied large sealing pad over the metal clamp and drain hose to insulate and fix it with clamps.
- 4 Insulate the complete drain piping inside the building (field supply).
If the drain hose cannot be sufficiently set on a slope, fit the hose with drain raising piping (field supply).
- 5 Push the drain hose up to insulation when connecting the drain hose to drain socket.

4 way Cassette

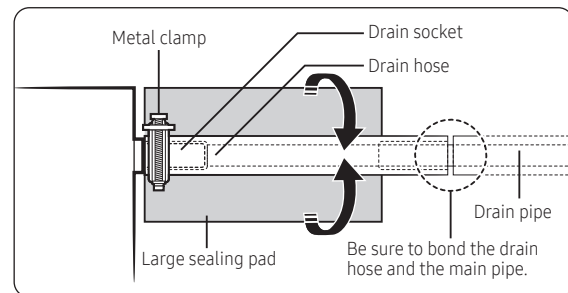

Installation

4 Way Cassette

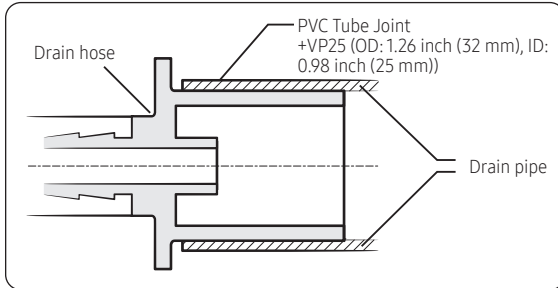

⚠ CAUTION

Check that the indoor unit is level with the ceiling by using a level.

- Install air ventilation to drain condensation smoothly.

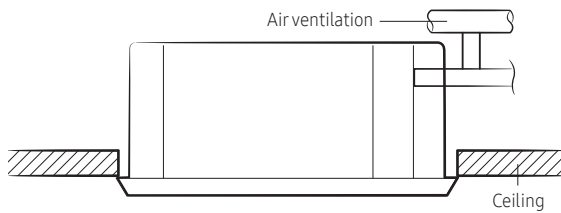

- If it is necessary to increase the height of the drain pipe, install the drain pipe straight within 11.81 inch (300 mm) from the drain hose port. If it is raised higher than 21.65 inch (550 mm), there may be water leaks.

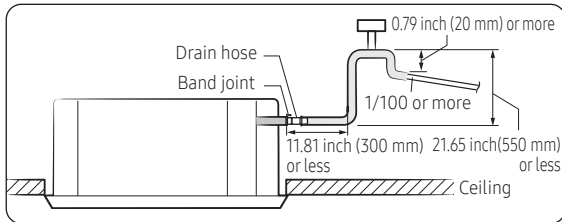

- Do not give the hose an upward gradient beyond the connection port. This will cause water to flow backwards when the unit is stopped, resulting in water leaks.

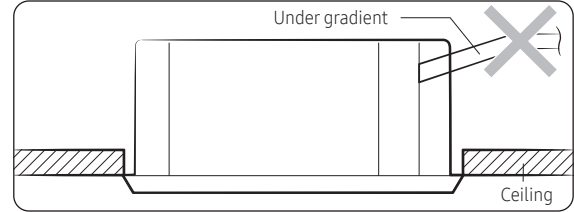

- Do not apply force to the piping on the unit side when connecting the drain hose. The hose should not be allowed to hang loose from its connection to the unit. Fasten the hose to a wall, frame or other support as close to the unit as possible.

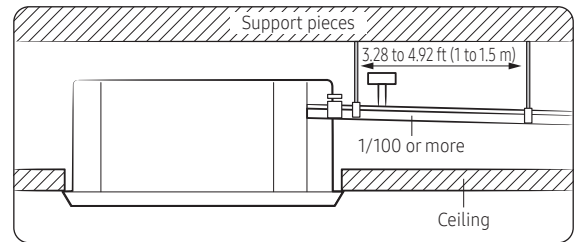

- Install horizontally.

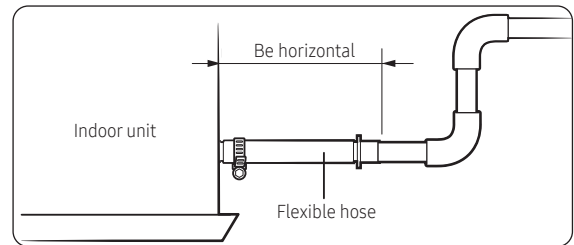

Installation

4 Way Cassette

- Max. allowable axis gap

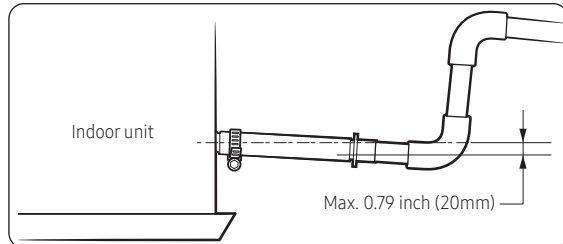

- Max. allowable bending angle

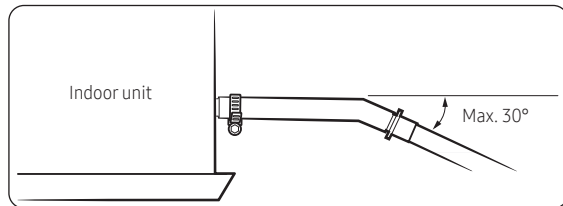

NOTE

- If a concentrated drain pipe is installed, refer to the figure below.

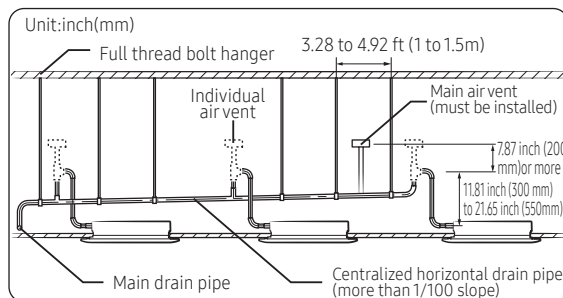

- If 3 or more units are installed, install a main air vent in front of the farthest indoor unit from the main drain pipe.
- To prevent water from flowing back to indoor units, install an individual air vent at the top of each indoor unit.
 - The air vents should be T or 7 shaped to prevent dust or foreign substances from entering.
 - You may not need to install an air vent if the horizontal drain pipe has a proper slope.

Connecting the power and communication cables

Bushing bracket installation

When connecting the power supply wire conduit, the supplied bracket must be installed as shown in the picture below.

4 way Cassette

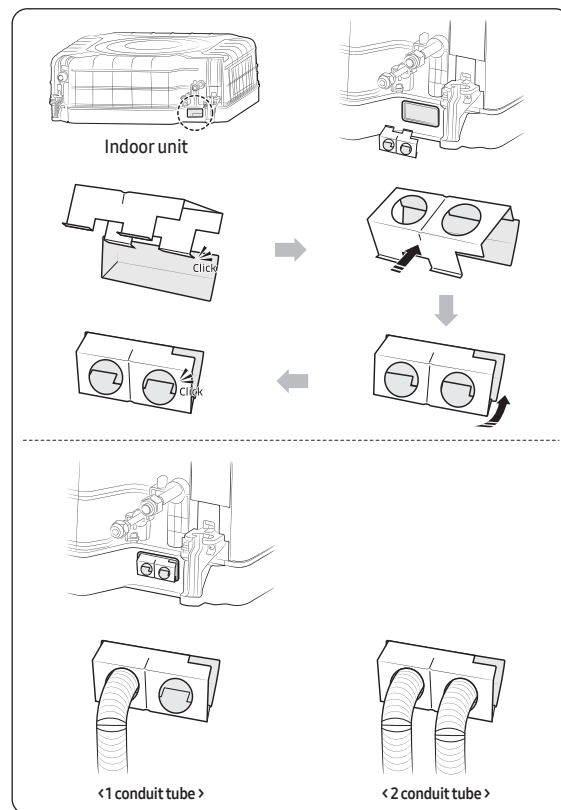

NOTE

- Please follow national and local electrical codes. Additional electrical connection components may be required.

CAUTION

- Always remember to connect the refrigerant pipes before performing the electric connections. When disconnecting the system, always disconnect the electric cables before disconnecting the refrigerant pipes.
- Always remember to connect the air conditioner to the grounding system before performing the electric connections. Use a crimp ring terminal at the end of each wire.

Installation

4 Way Cassette

The indoor unit is powered through the outdoor unit by means of a H05 RN-F connection cable (or a more power model), with insulation in synthetic rubber and a jacket in polychloroprene (neoprene), in accordance with the requirements specified in the standard EN 60335-2-40.

- 1 Remove the screw from the electrical component box and remove the cover plate.
- 2 Route the connection cord through the side of the indoor unit and connect the cable to the terminals refer to the figure below.
- 3 Route the other end of the cable to the outdoor unit through the ceiling & the hole on the wall.
- 4 Reassemble the electrical component box cover, carefully tightening the screw.

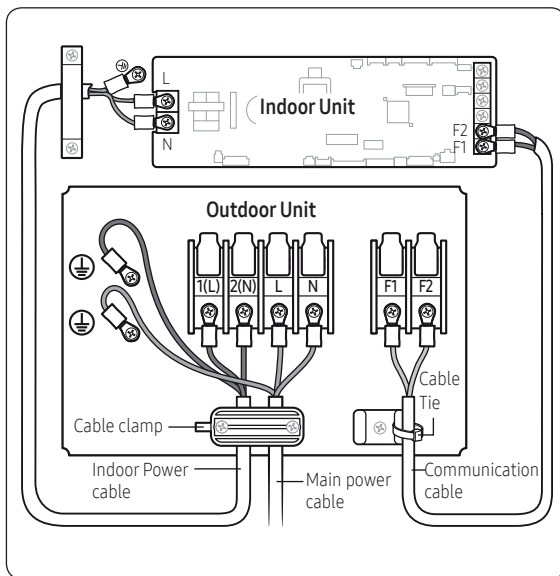

Indoor power supply		
Power supply	Max/Min(V)	Indoor power cable
208 to 230V, 60 Hz	±10%	0.0012 inch ² ↑ (0.75mm ² ↑), 3 wires
Communication cable		
0.0012 inch ² ↑(0.75mm ² ↑), 2 wires		

Unit: inch(mm)

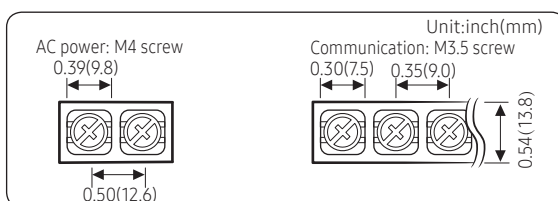

Tightening torque lbf-ft (kgf • cm)	
M3.5	0.58 to 0.87 (8.0 to 12.0)
M4	0.87 to 1.30 (12.0 to 18.0)

- Power supply cords of parts of appliances for outdoor use shall not be lighter than polychloroprene sheathed flexible cord. (Code designation IEC:60245 IEC 57 / CENELEC: H05RN-F)
- Since it has the external power supply, refer to the outdoor unit installation manual for MAIN POWER.

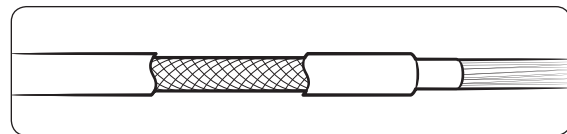

⚠ CAUTION

- When installing the indoor unit in a computer room or network room, use the double shielded communication cable (tape aluminum / polyester braid + copper) of FROHH2R type.
- Select the power cable in accordance with relevant local and national.
- Wire size must comply with local and national code.
- You should connect the power cable into the power cable terminal and fasten it with a clamp.
- The unbalanced power must be maintained within 10% of supply rating among whole indoor units.
- If the power is unbalanced greatly, it may shorten the life of the condenser. If the unbalanced power is exceeded by more than 10% of supply rating, the indoor unit will protect itself by stopping and displaying an error code.
- Connect the power cable to the auxiliary circuit breaker. An all pole disconnection from the power supply must be incorporated in the fixed wiring (≥0.12inch (3mm)).
- You must keep the cable in a protection tube.
- Maximum length of power cables are decided within 10% of power drop. If it exceeds, you must consider another power supplying method.
- The circuit breaker (MCCB, ELB) should be considered more capacity if many indoor units are connected from one breaker.
- Use round pressure terminal for connections to the power terminal block.
- For wiring, use the designated power cable and connect it firmly, then secure to prevent outside pressure being exerted on the terminal board.
- Use an appropriate screwdriver for tightening the terminal screws. A screwdriver with a small head will strip the head and make proper tightening impossible.
- Over-tightening the terminal screws may break them.

Installation

Duct

Spacing requirements

Space requirements for installation & service.

Construction Standard for Inspection opening

An inspection opening is required for service and unit replacement.

- 1) If the ceiling is a grid type, an inspection opening is not required.
- 2) If the ceiling is plaster board, an inspection opening is required. The size of the opening will vary based on the height inside the ceiling.
 - a. Height is more than 1.64ft (0.5m): Only "B" [Inspection for PBA] is applied.
 - b. Height is less than 1.64ft (0.5m): Both "A"&"B" are applied.
 - c. "A"&"B" are inspection opening .

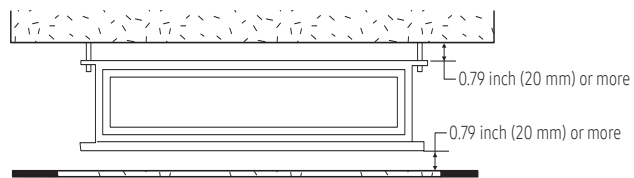
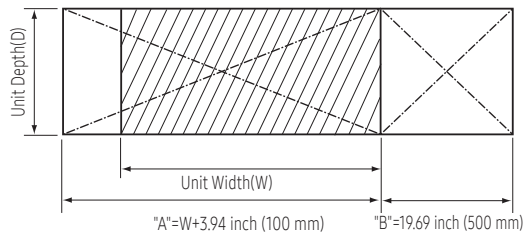

- You must have 0.79 inch (20 mm) or more space between the ceiling and the bottom of indoor unit to prevent transmission of noise and vibration from the unit into the space.
- It is possible to install the unit at an height of between 7.2~8.2 ft (2.2~2.5 m) from the ground, if the unit has a duct with a well defined length [11.81inch (300 mm) or more], to avoid fan motor blower contact.
- If you install the cassette or duct type indoor unit on the ceiling with humidity over 80%, you must apply extra 0.39 inch (10mm) of polyethylene foam or other insulation with similar material on the body of the indoor unit.

Optional: Insulating the body of the indoor unit

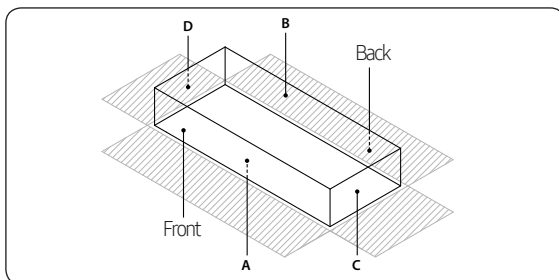

Thickness: more than 0.39 inch(10mm)

Unit: inch(mm)

Indoor Unit	AC030BNHDCH	AC036BNHDCH
		47.24X27.56X9.84 (1200X700X250)
A	47.24X27.5 (1200X700)	51.18X27.56 (1300X700)
B	47.24X27.5 (1200X700)	51.18X27.56 (1300X700)
C	27.56X9.84 (700X250)	27.56X11.81 (700X300)
D	27.56X9.84 (700X250)	27.56X11.81 (700X300)
Front/Back	Insulate the front and back side in proper size at the same time when insulating the suction duct and discharge duct.	

NOTE

- Insulate the end of the pipe and some curved area by using separate insulator.
- Insulate the discharge and suction part at the same time when you insulate connection duct.

Installation

Duct

Installing the indoor unit

When deciding on the location of the air conditioner with the owner, the following restrictions must be taken into account

- 1 Place the pattern sheet on the ceiling at the spot where you want to install the indoor unit.

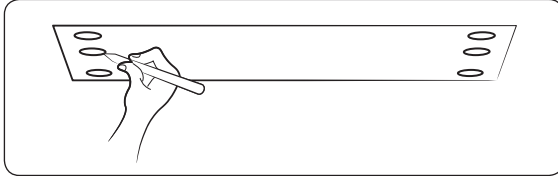

NOTE

- Since the diagram is made of paper, it may shrink or stretch slightly due to temperature or humidity. For this reason, before drilling the holes maintain the correct dimensions between the markings.
- 2 Insert bolt anchors. Use existing ceiling supports or construct a suitable support as shown in figure.

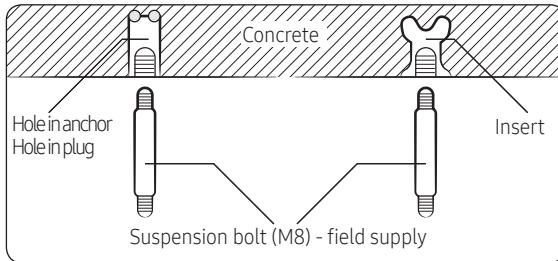

- 3 Install the suspension bolts depending on the ceiling type.

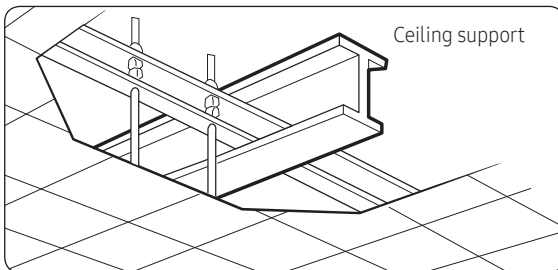

CAUTION

- Ensure that the ceiling is strong enough to support the weight of the indoor unit. Before hanging the unit, test the strength of each attached suspension bolt.
- If the length of suspension bolt is more than 4.92 ft (1.5m), it is required to prevent vibration.
- If this is not possible, create an opening on the false ceiling in order to be able to use it to perform the required operations on the indoor unit.

- 4 Screw eight nuts to the suspension bolts making space for hanging the indoor unit.

NOTE

- You must install all the suspension rods.
- 5 Hang the indoor unit to the suspension bolts between two nuts.

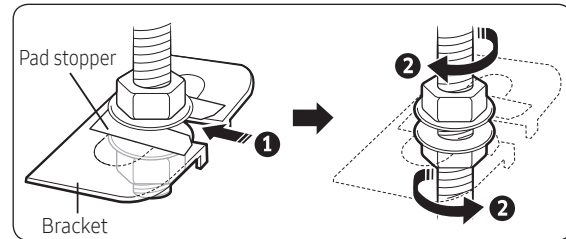

CAUTION

- Piping must be laid and connected inside the ceiling when suspending the unit. If the ceiling is already constructed, lay the piping into position for connection to the unit before placing the unit inside the ceiling.
- 6 Screw the nuts to suspend the unit.
- 7 Adjust level of the unit by using measurement plate for all 4 sides.

CAUTION

- For proper drainage of condensate, give a 0.118 inch (3mm) slant to the left or right side of the unit which will be connected with the drain hose, as shown in the figure. Make a tilt when you wish to install the drain pump, too.

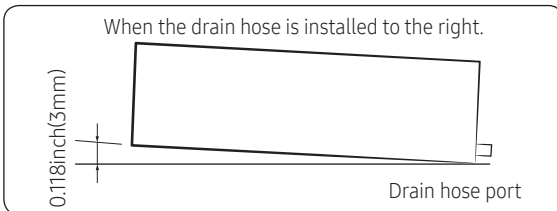

- When installing the indoor unit, make sure it is not tilted toward front or back side.

CAUTION

- Noise will increase 3~6 dB(A) when the air flow enters from the bottom side (Only for AC**BNLDCH indoor unit product).

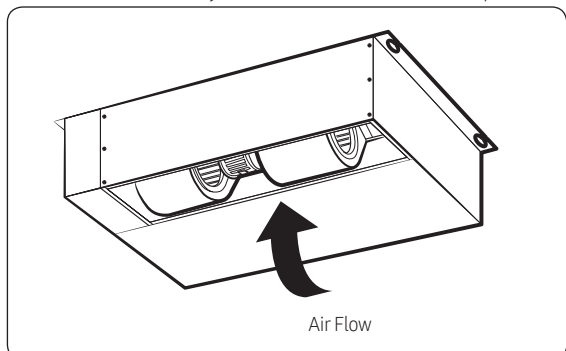

Installation

Duct

Installing the drain hose and drain pipe

- 1 Push the supplied drain hose as far as possible over the drain socket.
- 2 Tighten the metal clamp as shown in the picture.

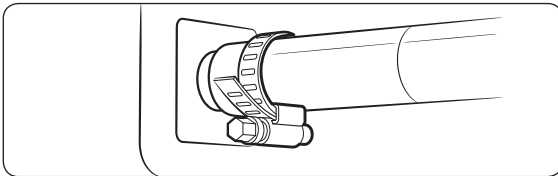

- 3 Wrap the supplied large sealing pad over the metal clamp and drain hose to insulate and fix it with clamps.
- 4 Insulate the complete drain piping inside the building (field supply). If the drain hose cannot be sufficiently set on a slope, fit the hose with drain raising piping (field supply).
- 5 Push the drain hose up to insulation when connecting the drain hose to drain socket.

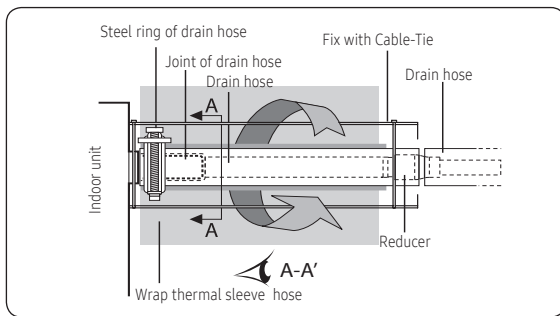

Without the drain pump

- 1 Install horizontal drainpipe with a slope of 1/100 or more and fix it by hanger space of 3.28~4.92ft(1~1.5m).
- 2 Install U-trap at the end of the drainpipe to prevent a nasty smell to reach the indoor unit.
- 3 Do not install the drainpipe to upward position. It may cause water flow back to the unit.

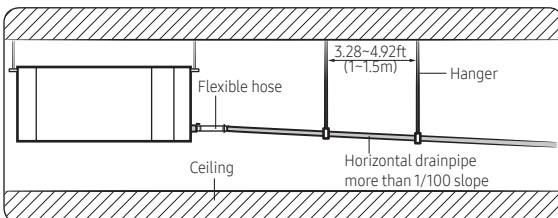

With the drain pump

- 1 The drain pipe should be installed within 11.81inch(300mm) to 21.65inch(550mm) from the flexible hose and then lift down 0.79inch(20mm) or more.
- 2 Install horizontal drainpipe with a slope of 1/100 or more and fix it by hanger space of 3.28~4.92ft(1~1.5m).
- 3 Install the air vent in the horizontal drainpipe to prevent water flow back to the indoor unit.

NOTE

- You may not need to install it if there were proper slope in the horizontal drainpipe.
- The flexible hose should not be installed upward position, it may cause water flow back to the indoor unit.

Centralized drainage without the drain pump

- 1 Install horizontal drainpipe with a slope of 1/100 or more and fix it by hanger space of 3.28~4.92ft(1~1.5m).
- 2 Install U-trap at the end of the drainpipe to prevent a nasty smell to reach the indoor unit.

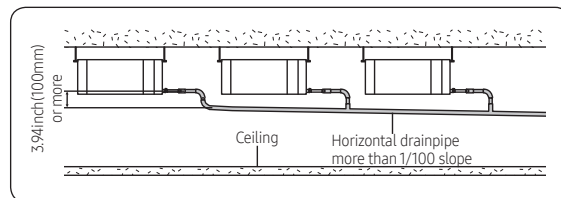

Centralized drainage with the drain pump

- 1 Install main air vent at the front of the farthest indoor unit from the main drain when installed indoor units are more than 3.
- 2 You may need to install individual air vent to prevent water flow back at the top of each indoor unit drainpipe.

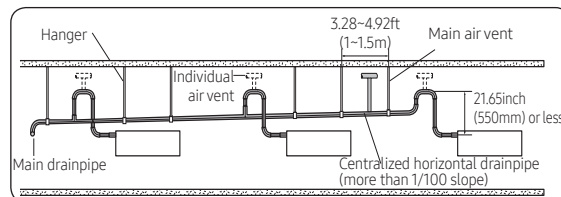

Installation

Duct

Connecting the power and communication cables

⚠ CAUTION

- Always remember to connect the refrigerant pipes before performing the electric connections. When disconnecting the system, always disconnect the electric cables before disconnecting the refrigerant pipes.

⚠ CAUTION

- Always remember to connect the air conditioner to the grounding system before performing the electric connections. Use a crimp ring terminal at the end of each wire.

The indoor unit is powered through the outdoor unit by means of a H05 RN-F connection cable (or a more power model), with insulation in synthetic rubber and a jacket in polychloroprene (neoprene), in accordance with the requirements specified in the standard EN 60335-2-40.

- Remove the screw on the electrical component box and remove the cover plate.
- Route the connection cord through the side of the indoor unit and connect the cable to the terminals refer to the figure below.
- Route the other end of the cable to the outdoor unit through the ceiling & the hole on the wall.
- Reassemble the electrical component box cover, carefully tightening the screw.

AC***BNHDCH

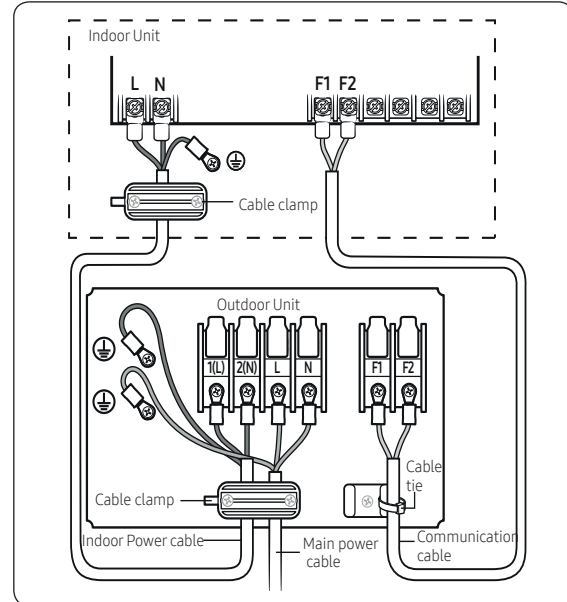

📄 NOTE

- Terminal Block of the outdoor unit may be different from the diagram depending on the model. Refer to the manual of the outdoor unit for the configuration of the terminal block of the outdoor unit.

Indoor power supply		
Power supply	Max/Min(V)	Indoor power cable
208 to 230V, 60 Hz	±10%	0.0023 inch ² ↑ (1.5mm ² ↑), 3 wires
Communication cable		
0.0012 inch ² ↑ (0.75mm ² ↑), 2 wires		

Installation

Duct

AC***BNHDCH

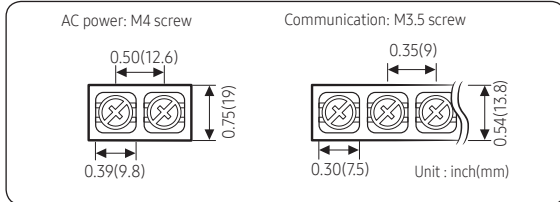

Tightening torque lbf·ft (kgf·cm)	
M3.5	0.58 to 0.87 (8.0 to 12.0)
M4	0.87 to 1.30 (12.0 to 18.0)

- Power supply cords of parts of appliances for outdoor use shall not be lighter than polychloroprene sheathed flexible cord.
-Code designation
[1-phase] IEC: 60245 IEC 57 / CENELEC: H05RN-F grade or more
- Be sure to run the power supply cable and the communication cable through electrical conduit as seen in the picture.

AC***BNHDCH

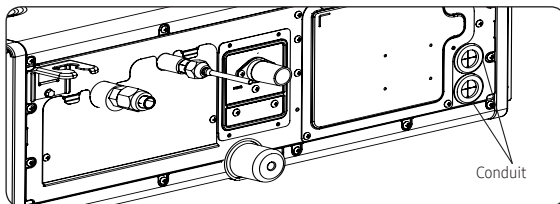

⚠ CAUTION

- Be sure not to put your finger into the conduit.
- Since it has the external power supply, refer to the outdoor unit installation manual for MAIN POWER.

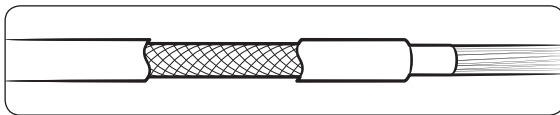

⚠ CAUTION

- When installing the indoor unit in a computer room or a server room, use the double shielded communication cable (tape aluminum / polyester braid + copper) of FROHH2R type.

Installation

Multi-position AHU

Selecting the installation location

Decide the installation location, with the consideration of the following conditions, under user's approval.

- Place where airflow is not disturbed
- Place on flat surface where the structure can bear the weight and vibration of the indoor unit. (If the structure is not strong enough, indoor unit may fall and be damaged or cause personal injury)
- Place where sufficient space can be guaranteed for maintenance and other services.
- Place where condensation can be drained easily.
- Place that allows refrigerant pipe connection within allowable distance.
- Place where indoor unit will not be exposed to direct sunlight.
- Place that can keep the distance of at least 3.28 ft (1 m) between power/communication cable and any electronic devices (depending on the circumstances, problem may occur even if you secure 3.28 ft (1 m) of distance).

Indoor unit installation

Refrigerant pipe work must be done before installing the indoor unit.

Location

Access for servicing is an important factor in the location of any air handler. Provide a minimum of 30 inches in front of the appliance for access to the control box, heating elements, blower and air filters. This access may be provided by a closet door or by locating the appliance so that a wall or partition is not less than 30 inches from the front access panel. Location is usually predetermined. Refer to figure below. Check with owner's or dealer's installation plan. If location has not been decided, consider the following in choosing a suitable location.

1. Select a location with adequate structural support, space for service access, and clearance for return and supply duct connections.
2. Normal operating sound levels may be objectionable if the air handler is placed directly over or under some rooms such as bedrooms, study, etc.
3. Caution should be taken to locate the unit so that supply and return air ducts are about the same length causing even air distribution of supply and return air to and from the living spaces.
4. Locate appliance where electrical supply wiring can be easily routed to main electrical panel and where electrical wiring will not be damaged.
5. Locate appliance where control wiring can be easily routed to the controller and where the wiring will not be damaged.
6. Locate appliance where refrigerant lines can be easily routed from the evaporator coil to the system.
7. Locate the appliance where condensate lines can be easily routed to an available drain. Be sure to route condensate drain piping so as not to obstruct access to the air filter.
8. The coil is installed in a draw-thru application and will create a negative pressure situation in the condensate drain system. To prevent condensate from being drawn into the blower it is recommended to trap the primary (Main) and secondary (Overflow) drain line. Refer to Drain Pipe and Drain Hose section in these instructions. If the secondary drain is not used, it must be capped. This unit has a connection terminal for drain system monitoring. Refer to Wiring Work section for information regarding connection of field-provided condensate overflow devices in these instructions.
9. The draw-thru design will cause exterior surface of cabinet to sweat when unit is installed in a non-conditioned space such as an attic or garage. Installer must provide protection such as full size auxiliary drain pan on all units installed in a non-conditioned space to prevent damage from condensation runoff. Some states, cities and counties require additional insulation to be installed on the exterior casing of the air handler to prevent sweating. Refer to the state, city, county or local code for insulation requirement to be sure the installation is in compliance. It is recommended that air handlers installed in non-conditioned spaces be insulated on the exterior of the entire cabinet, including the front access panel with one (1) inch thick fiberglass with the vapor barrier on the outside.
10. Ensure sufficient space for the bottom of the product (H dimension) so that a downward slope of 1/100 can be maintained for drain piping, as described for the intake duct installation and in "Drain pipe installation".

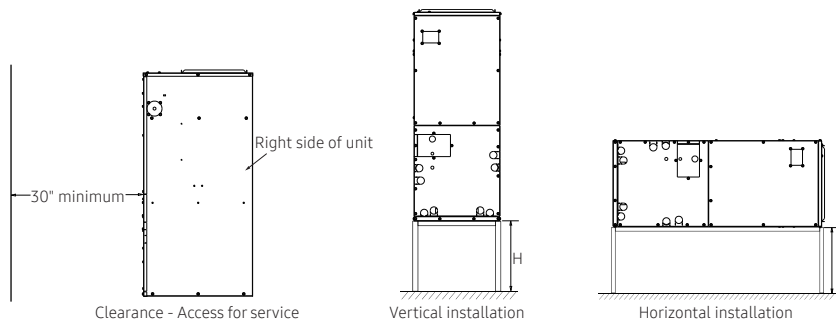

Installation

Multi-position AHU

This appliance is approved for zero (0) inches clearance to combustibile material on any part of the air handler exterior casing and the inlet or outlet ducts providing NO electric heater is being used. There is a one (1) inch clearance on the supply plenum and supply air duct when an electric heater is installed in the appliance. Refer to Table below for clearance to combustibles information.

Top (inches)	Back (inches)	Sides (inches)	Front of unit		Duct (inches)
			Alcove (inches)	Closet (inches)	
0	0	0	30	6	1 *

* when electric heat kit accessory is installed

Return air requirements

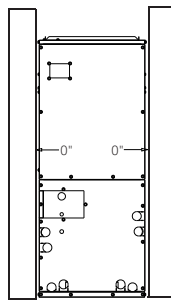

Return Air Requirements

In order for the air handler to work properly, a closet or alcove must have a certain total free area opening for the return air.

For A/C and HP Air Handlers 1/3 HP Blower Motor

Minimum 200 in² free area opening

- Use Return Grille that can supply sufficient air to ensure proper performance.

For A/C and HP Air Handlers 1/2 HP Blower Motors

Minimum 250 in² free area opening

- Use Return Grille that can supply sufficient air to ensure proper performance.

For A/C and HP Air Handlers with Electric Heat use 3/4 HP Blower Motor

Minimum 390 in² free area opening

- Use Return Grille that can supply sufficient air to ensure proper performance.

The return air opening can be located in the floor, on a closet front door or in a sidewall above the air handler casing. If opening for the return air is located in the floor, sidewalls, or closet door anywhere below the appliance casing, a 6 inch minimum clearance between the appliance and the wall or door must be provided on the side where the return is located to provide for proper airflow. The 6 inch minimum clearance is not required if there is a return grille installed above the appliance casing, providing the grille has a sufficient return air opening.

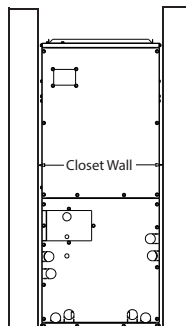

Typical Closet Installations

Provisions shall be made to permit the air in the rooms and the living spaces to return to the air handler. Failure to comply may cause a reduction in the amount of return air available to the blower, causing reduced airflow resulting in improper heating and cooling of the living space. The reduced air may cause the airflow handler to cycle on the limit causing premature heating element failure (if electric heat kits are installed).

Upflow Accessory Filter Box Kit

An accessory filter box kit can be used on the return air end of the air handler when configured in the upflow position. The filter kit is placed over the return plenum in the floor and sealed to the plenum using sealant or caulking material and/or tape. The air handler is placed on top of the return filter box and the return opening sealed to prevent leaks.

Installation

Multi-position AHU



Make sure the flow arrow on the air filter is pointing towards the coil.

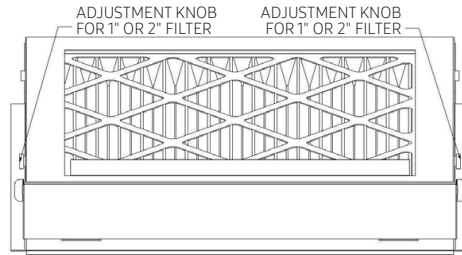

Accessory Air Filter Box for 1" or 2" Air Filters. Filter Size Adjustment knob is on both sides.

FILTER BASE ASSEMBLY KIT MODEL NUMBERS - FIELD INSTALLED, PURCHASED SEPARATELY

VFB-1 – 16" X 20" X 2" Small Cabinet (12/18/24K)

VFB-2 – 20" X 20" X 2" Medium Cabinet (30/36K)

VFB-3 – 20" X 24" X 2" Large Cabinet (42/48K)

Arrangement:

Unit is shipped from the factory arranged to be installed in an upflow or horizontal left (right to left airflow) position. Horizontal left means when the unit is laid on its side and you are facing the unit, the supply air opening is to the left and the return opening is to the right. These models are field convertible to a horizontal right (left to right) airflow position.

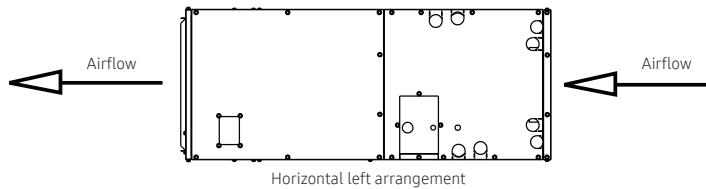

Upflow application

In an upflow installation the discharge outlet is at the top. Care should be taken to insure unit is level to permit proper condensate drainage. Normal upflow installation will be in a closet or basement. If installed in a closet, it must have a platform framed in. The platform must have an opening centered in the closet that measures at least 12 inches in height from the floor. A filter frame and filter can be used that covers the opening and is sealed to prevent air by-passing the filter. A filter grille can be used that is detailed as described in RETURN AIR REQUIREMENTS section. The minimum filter size is shown in the table below.

Standard throw away airfilter @ 300ft/min or less

- 800 CFM = 20 x 20 x 1
- 1000 CFM = 20 x 25 x 1
- 1200 CFM = 20 x 30 x 1
- 1400 CFM = 25 x 30 x 1
- 1600 CFM = 25 x 30 x 1
- 1800 CFM = 30 x 30 x 1
- 2000 CFM = 30 x 40 x 1 or two 30 x 20 x 1
- 2400 CFM = 30 x 40 x 1 or two 30 x 20 x 1

Pleated Air Filter @ 500ft/min or less

- 800 CFM = 16 x 16 x 1
- 1000 CFM = 18 x 20 x 1
- 1200 CFM = 20 x 20 x 1
- 1400 CFM = 20 x 20 x 1
- 1600 CFM = 20 x 25 x 1
- 1800 CFM = 20 x 30 x 1 or two 20 x 15 x 1
- 2000 CFM = 20 x 30 x 1 or two 20 x 15 x 1
- 2400 CFM = 25 x 30 x 1 or two 14 x 30 x 1

Another option is to use the Filter Base Accessory Kit. The filter base is placed on the cabinet floor and secured with screws. The unit is placed on top of the filter base and secured to the base with screws. Use seal strip tape or galing to seal between the unit and the base.

Connect the supply air outlet to a plenum to the top of the unit and secure it with screws. Use a Non-tape sealant such as mastic or an aerosol sealant to seal duct leakage. If installed in a basement, run supply and return duct work in accordance with local codes. Use a Non-tape sealant such as mastic or an aerosol sealant to seal duct leakage.

Installation

Multi-position AHU

Horizontal application

Horizontal applications will normally be used in an attic or crawl space. This type of installation requires supply air plenum or duct to be connected to the supply collar and a return air plenum or duct be attached to the unit inlet collar. The supply ducts will be connected to the supply air plenum and routed through the attic to a register in each room. Use a Non-tape sealant such as mastic or an aerosol sealant to prevent leaks in the ducts and the plenum.

The opposite end of the return air duct is attached to a return filter grille housing. The filter grille is usually located in a wall, just below the ceiling or the ceiling in a hallway. Use a Non-tape sealant such as mastic or an aerosol sealant to prevent leaks in the ducts and the plenum.

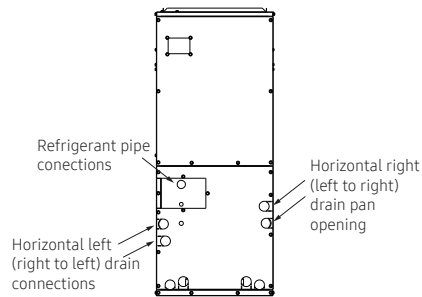

Horizontal right application (left to right)

The unit is shipped to be installed without modification in a right to left configuration. For left to right applications:

1. Remove the unit access panels
2. Remove the cooling coil after disassembling bracket coil and plate.
3. Move the condensate drain pan to the right side of the unit chassis.
4. Move the Evap. In temperature sensor to holder of the right side.
5. Reinstall the cooling coil.
6. Connect the condensate drains and refrigerant lines. DRY NITROGEN MUST BE FLOWED THROUGH REFRIGERANT LINES DURING SOLDERING OPERATION.
7. Reinstall unit access panels.

※ In all horizontal applications in which the unit is installed above a finished ceiling and/or living space, it is recommended that a secondary drain pan (field supplied) is installed under the entire unit to avoid damage to the ceiling in the event of condensate overflow.

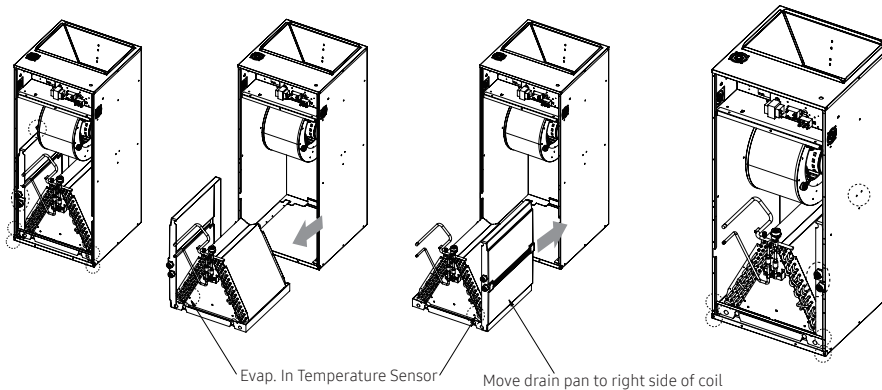

Closet installation

Prior to installing the air handler make sure holes are cut into the floor for refrigerant tubing, drain line, electrical wiring, and control wiring.

1. Remove the top shipping cover and corner posts.
2. Remove the bottom shipping cover.
3. Remove the blower and control box access panel (door).
4. Remove the coil compartment access panel (door).
5. Place the unit into position by sliding the unit over the duct opening until the opening in the unit lines up with the duct opening in the floor.
6. Secure the unit to the floor by drilling two holes through the air handler base at the left and right front inside corners of the cabinet. Use two screws to secure the unit to the floor.
7. Use calking, sealers, and/or tape to seal between the floor base and the opening on the unit or between the opening on the unit and the duct in the floor.
8. Connect the electrical supply wires and the control wires in the control box.
9. Connect the refrigerant lines to the coil. DRY NITROGEN MUST BE FLOWED THROUGH REFRIGERANT LINES DURING SOLDERING OPERATION.
10. Re-install the coil compartment access panel (door) and secure with the screws that were removed in step 3.
11. Re-install the blower and control box access panel (door) and secure with the screws that were removed in step 2.

Installation

Multi-position AHU

Air Handlers with DX type evaporator coils require liquid and suction piping sized in accordance with condensing unit manufacturer's instructions. The evaporator coils have sweat copper connections. Refrigerant lines should be soldered with silver solder or high temperature brazing alloy.

DRY NITROGEN MUST BE FLOWED THROUGH REFRIGERANT LINES DURING SOLDERING OPERATION.

REFER TO OUTDOOR UNIT INSTALLATION MANUALS FOR PRESSURE CHECKING AND VACUUM DRYING PROCEDURES.

There are two refrigerant pipes of differing diameters:

- A smaller one for the liquid refrigerant
- A larger one for the gas refrigerant
- The inside of copper pipe must be clean & have no dust.

Prepare the connecting pipe referring to the list below.

- Refrigerant pipe diameters

Unit : inch(mm)

	AC030/036*NZDCH
Liquid pipe	3/8 (9.52)
Gas pipe	5/8 (15.88)

Drain pipe installation

The air handler "A" coil drain pan has two 3/4 NPT (19.05mm) female primary and two secondary connections (left or right hand). The horizontal pan has two 3/4 NPT (19.05mm) female, one primary and one secondary. Piping from each fitting used is to have 2 inch (50.8mm) minimum trap and each run in such a manner to provide enough slope for adequate drainage to a visible area. Do not pipe these two fittings together into a common drain. Prime drain with water before operating the unit by pouring water into the condensate pan. Cap unused connections.

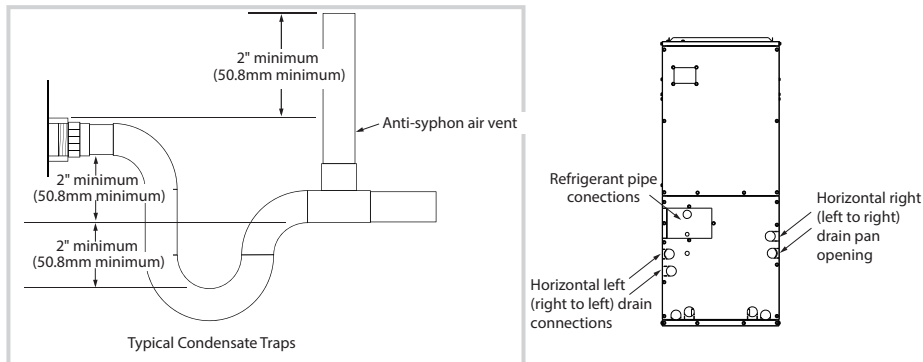

- Make sure to keep the drain hose from getting tangled or loosened (on the connection part).
- Insulate all condensate pipes connected to the indoor unit to prevent condensation formation. Condensate formation on condensate pipes can lead to property damage and unsafe environment conditions.

When passing the drain hose through the hole drilled in the wall, make sure to avoid following cases.



- Since the draining is of natural drain type, install the drain hose in downward direction.
- If you do not tie the drain hose with a cable tie, leakage may occur
- Drain pipe may get clogged if there is any foreign substances within the drain pan, so you must remove any foreign substances after completing the installation.

Installation

Multi-position AHU

Wiring Work



- For personal safety be sure to turn the electrical power "OFF" at the main entrance (Home Circuit Breaker Box) and at the unit control box circuit breakers before attempting any service or maintenance operations. Homeowners should never attempt to perform any maintenance which requires opening the air handler control box door.
- This air handler is not equipped with a shield that covers the line voltage electrical supply wires and the circuit breaker connections. Take precautions to prevent accidental electrical shock. Be sure to turn the electrical power "OFF" at the main entrance (Home Circuit Breaker Box) and at the control box circuit breakers before removing the front panel.

Power supply wiring

- The unit internal wiring is complete except for the power supply and control wires.
- The use of cable connectors on incoming power supply wires to relieve any strain on wiring is recommended.
- Follow the steps below to connect the power supply wires.
- Supply voltage is 208/230V, 1Ø, 60 Hz.
- If you are installing optional heat kits, refer to the heat kit installation instructions for line voltage connection instructions

Wiring diagram

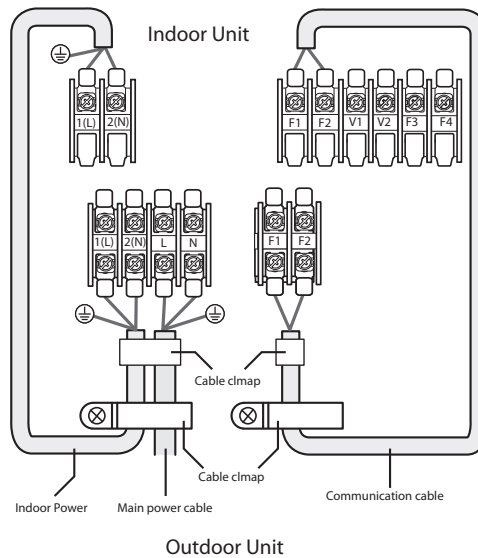

Between Indoor and Outdoor Connection cable Specifications(Common in use)

Indoor Power supply			Communication Cable
Power Supply	Max/Min(V)	Indoor Power cable	
208~230V/60Hz	±10%	0.0039in ² ↑3wires (2.5mm ² ↑3wires)	0.0012 inch ² ↑, 2wires (0.75mm ² ↑, 2wires)

- Selecting wire size must comply with local and national code.
- Power supply cords of parts of appliances for outdoor use shall not be lighter than polychloroprene sheathed flexible cord. (Code designation IEC:60245 IEC 57 / CENELEC: H05RN-F)
- Screws on terminal block must not be unscrewed with the torque less than 12 kgf•cm (086 lb•ft).
- Since it has the external power supply, refer to the outdoor unit installation manual for MAIN POWER.

Installation

Multi-position AHU

Terminal Block SPEC (Indoor)

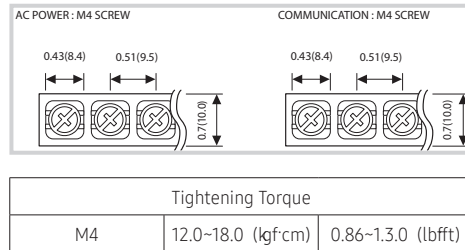

In case of extending the electric wire, please DO NOT use a round-shaped pressing socket.

- Incomplete wire connections can cause electric shock or afire.

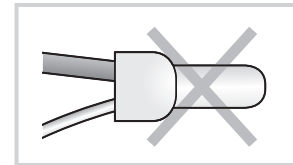

Wiring Work

Single circuit line wiring connections



If an accessory heat kit is installed, power must enter the unit on the top or the top-left side of the unit as shown below (A).

1. Before wiring work, you must turn off all power source.
2. Only copper power cables should be used.
3. Remove the blower and control box access panel (door).
4. Install the cable connectors on the 7/8" diameter holes on the right side of the control box.
5. Insert the wires through the holes in the casing and through the cable connectors.
6. Connect the black supply wire to the L1[1(L)] high voltage connection terminal with compressed ring terminals.
7. Connect the white supply wire to the L2[2(N)] high voltage connection terminal with compressed ring terminals.
8. Connect the green wire to the ground lug near the supply wire connections with a compressed ring terminal and tighten the ground screw. Make sure to leave extra slack in the ground wire to allow service to the unit without disconnecting the ground wire.

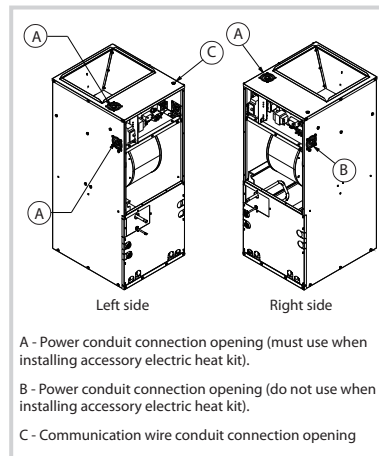

IMPORTANT -All insulation on field wiring must be rated at 140°F (60°C) or higher. Please refer to the wiring diagrams on the air handler or the tables in this manual for more information.

IMPORTANT - Refer to the NEC National Electrical Code (NFPA 70) or the Canadian Electrical Code, Part I (CSA C22.1) and local codes for wiring material requirements.

Installation

Multi-position AHU

Power supply wiring with accessory electric heat kit

1. Before wiring work, you must turn off all power source.
2. Only copper power cables should be used.
3. Remove the blower and control box access panel (door).
4. Install the cable connectors on the 7/8" diameter holes on the left side of the control box.
5. Connect the included power pigtail leads with ring connectors (included with heat kit) to 1(L) and 2(N) terminals located on the right side of the control box.
6. Route the power pigtail leads through the control box opening pictured below and route to the left side of the control box for connection to the heat breakers in a later step.

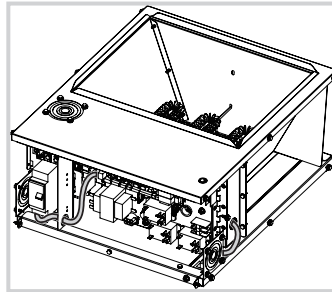
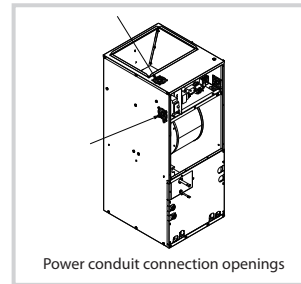

7. Swing the hinged control plate outward exposing the back side of the control box. Remove the screws holding the electric heat kit block off plate. Save the screws.
8. Carefully pass the accessory heating element through the rectangular opening in the discharge of the air handler and secure the heating element with the screws from step 8. Heating element support rod must be seated in the hole on the opposite side of the discharge.

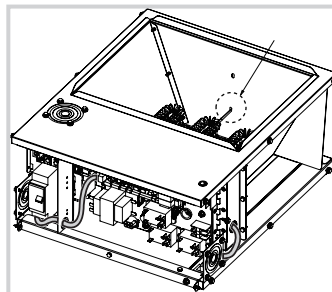

9. Install the breakers at the front-left of the control box.
10. Connect the power pigtail leads that are connected to 1(L) and 2(N) to the bottom of the breakers.
11. Insert the power wires through the holes in the casing and through the cable connectors.
12. In order to use heating function, you need change the installation option code. Set SEG10 to 1. For more information on changing the option code, refer to "Setting an indoor unit installation option".

Power supply wiring with accessory electric heat kit

13. Strip 1/2" of the insulation on the end of each power wire.
14. Connect the black supply wire to the high voltage connection lug on the accessory heat kit breaker.
15. Connect the white supply wire to the other high voltage connection lug on the accessory heat kit breaker.

Installation

Multi-position AHU

16. Connect the green (ground) wire to the ground lug to the left of the accessory heat kit breakers and tighten the ground lug screw. Make sure to leave extra slack in the ground wire to allow service to the unit without disconnecting the ground wire. If the heat kit requires 2 circuits (dual circuit), both circuit ground wires must be connected to a ground lug (dual circuit kits have two individual ground lugs).

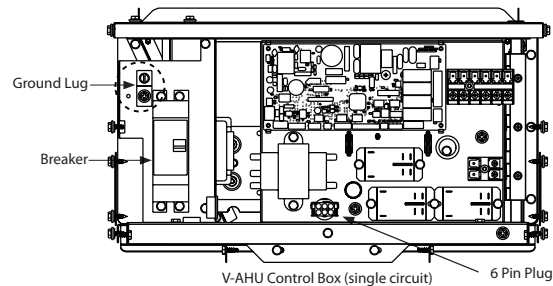

17. Connect the six pin male plug on the electric heater assembly to the six pin female plug mounted at the bottom of the control assembly door.
18. Remove the wiring diagram from the accessory heat kit. Remove the paper that covers the adhesive back and place the electric heat wiring diagram over the wiring diagram located on the blower housing.
19. Route temperature sensor from the accessory electric heat kit to the lower section of the AHU cabinet. Attach the sensor to the bottom of the liquid pipe as shown below with included wire ties.

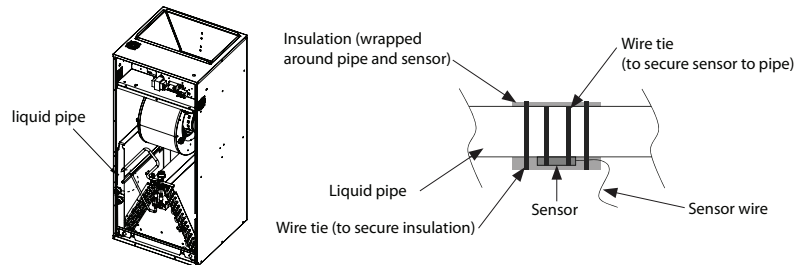

20. Wrap included insulation around the sensor and secure with included wire ties.
 21. Remove the breaker opening cover plate on the AHU door and secure the doors to the unit.
- NOTE:** The electric heat kits are equipped with either one or two circuit breakers. These circuit breakers protect the wiring inside of the AHU in the event of a short circuit. Additionally, these breakers provide a means of disconnecting the power to the unit. The circuit breakers in the AHU's are not meant to protect the branch circuit wiring between the furnace and the building's breaker panel. If sheathed cable is used, refer to NEC National Electrical Code (NFPA 70) or the Canadian Electrical Code, Part I (CSA C22.1) and local codes for additional requirements concerning supply circuit wiring. Electrical data can be found in page 21.
- IMPORTANT** -All installation or field wiring must be at 60°C or higher. Please refer to the wiring diagrams on the furnace or the tables in this manual for more information. The 15kW and 20kW models may be connected to a single or dual branch circuit. Refer to the NEC National Electrical Code (NFPA 70) or the Canadian Electrical Code, Part I (CSA C22.1) and local codes for wiring material requirements.

Installation

Multi-position AHU

Power supply connections

If the air handler has been installed prior to installing the electric heaters or if an older unit is being replaced, the supply power wires must be checked to make sure the wires are the proper sizes to handle the current load for the heaters. Refer to table below for correct wire size. If the supply power wire size is incorrect, new wires will need to be installed. Follow the instructions "Power supply wiring" of these instructions for proper installation.

ELECTRICAL DATA																				
Indoor Unit Model	Electric Heater Data						Minimum Circuit Ampacity (MCA)				Maximum Overcurrent Protection (MOCP)				Minimum Wire Size (AWG)				Short-Circuit Current Rating	
	Circuit Qty.	Kw (2)	Amps 208V	Amps 208V	Amps 240V	Amps 240V	208V	208V	240V	240V	208V (3,4)	208V (3,4)	240V (3,4)	240V (3,4)	Circuit 1		Circuit 2		"SCCR"	
			Circuit 1	Circuit 2	Circuit 1	Circuit 2	Circuit 1	Circuit 2	Circuit 1	Circuit 2	Circuit 1	Circuit 2	Circuit 1	Circuit 2	167°F (75°C) / 194°F (90°C)	140°F (60°C) / 194°F (90°C)	167°F (75°C) / 194°F (90°C)	140°F (60°C)	kA rms symmetrical	V maximum
MEDIUM CABINET-NOMINAL 2.5, 3.0 TONS (0 To 10 Kw)																				
AC030KNZDCH /AA	1	5	18.03	-	20.83	-	24.20	-	27.70	-	30.0	-	30.0	-	#10	#10	-	-	n/a	n/a
AC036KNZDCH /AA	1	10	36.06	-	41.67	-	46.73	-	53.74	-	50.0	-	60.0	-	#6	#4	-	-	n/a	n/a

1. Rated Motor Amps (at DOE External Static Rating Point)
 2. Nominal Kw At 240V (Derate 25% For 208V)
 3. Fuse or HACR Breaker
 4. Maximum Overcurrent Device, Overcurrent Protection Installed On Breaker Models Are Sized Per MCA
- To prevent damage, carefully insert the electric heating assembly through the rectangular opening in the front of the discharge opening so the heat element support rod is seated into the hole on the back side of the discharge opening.
 - After installing the electric heater, a one inch clearance must be maintained on all sides of the supply air duct and/or plenum for a minimum of thirty six inches from the air handler discharge opening.

Installation

Multi-position AHU

Communication wiring connections

- Communication wires connect through side of air handler.
- Use an approved connector at the cabinet of the unit to prevent pulling or shorting of control wires.



- Control wire must be rated for 600V minimum.
- Control wire insulation must be rated for temperatures up to 90°C.

1. Insert the wires through the holes of the right side on the top casing and through the cable connectors.
2. Connect the communication wires to the F1/F2 connection terminal with compressed ring terminals.
3. Connect F3, F4 (for communication) when installing the wired remote control.

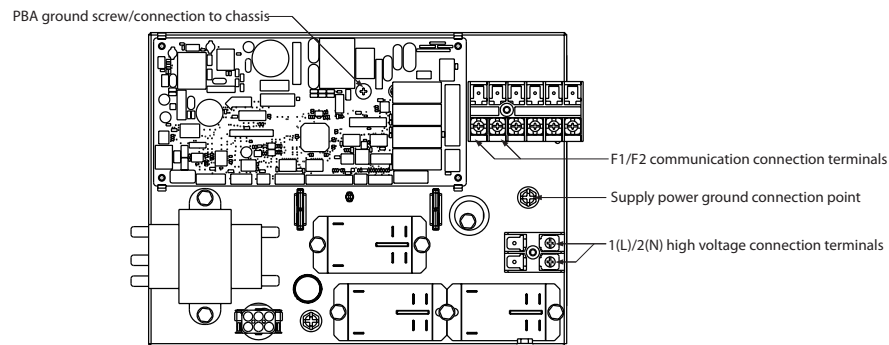

Installation

Outdoor Units

Choosing the installation location

Installation location requirements

- Do not place the outdoor unit on its side or upside down. Failing to do so may cause the compressor lubrication oil to run into the cooling circuit and lead to serious damage to the unit.
- Install the unit in a well-ventilated location away from direct sunlight or strong winds.
- Install the unit in a location that would not obstruct any passageways or thoroughfares.
- Install the unit in a location that would not inconvenience or disturb your neighbors, as they could be affected by the noise or the airflow coming from the unit.
- Install the unit in a location where the pipes and the cables can be easily connected to the indoor unit.
- Install the unit on a flat, stable surface that can withstand the weight of the unit. Otherwise, the unit can generate noise and vibration during operation.
- Install the unit so that the air flow is directed towards the open area.
- Maintain sufficient clearance around the outdoor unit, especially from a radio, computer, stereo system, etc.

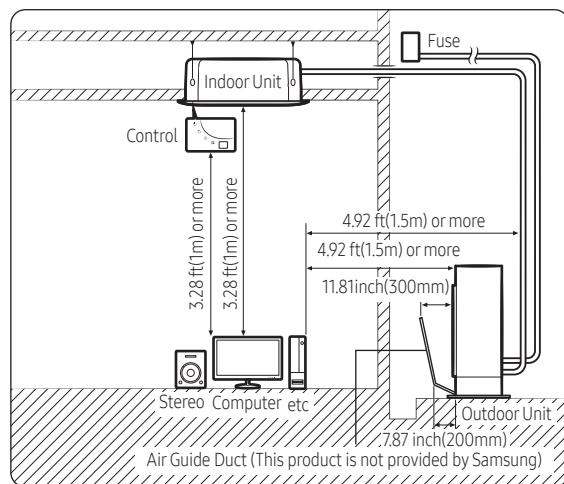

⚠ CAUTION

- You have just purchased a system air conditioner and it has been installed by your installation specialist.
- This device must be installed according to the national electrical rules.
- If your outdoor unit exceeds a net weight of 132.2 lb (60 kg), do not install it on a suspended wall, but stand it on a floor.
- The reliability of our product cannot be guaranteed under conditions of "A" or less.

Outdoor Model	"A"
AC030/036BXSCCH	-13°F(-25°C)

- When installing the outdoor unit at the seaside, make sure that it is not directly exposed to sea breeze. If you cannot find an adequate place free from direct sea breeze, construct a protection wall or a protective fence.
 - Install the outdoor unit in a place (such as near buildings etc.) where it can be prevented from sea breeze. Failure to do so may cause a damage to the outdoor unit.

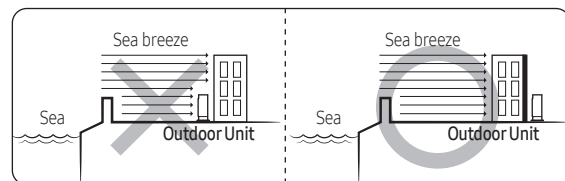

- If you cannot avoid installing the outdoor unit at the seaside, construct a protection wall around to block the sea breeze.
- Construct a protection wall with a solid material such as concrete to block the sea breeze. Make sure that the height and the width of the wall are 1.5 times larger than the size of the outdoor unit. Also, secure a space larger than 27.6 inch (700mm) between the protection wall and the outdoor unit for exhausted air to ventilate.

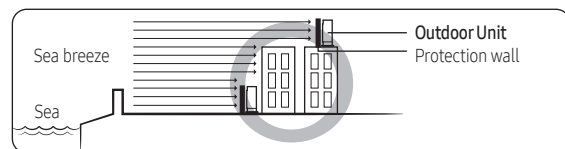

⚠ CAUTION

- Depending on the condition of the power supply, unstable power or voltage may cause malfunction of parts or control system (example: on a boat or places using power supplied from electric generator, etc.).

Installation

Outdoor Units

- Install the unit in a place where water can drain smoothly.
- If you have any difficulty finding installation location as prescribed above, contact your manufacturer for details.
- Consider that the salinity particles clinging to the external panels should be sufficiently washed out. Be sure to clean sea water and dust from the outdoor unit heat exchanger and apply a corrosion inhibitor on it at least once a year.
- Because the residual water at the bottom of the outdoor unit significantly promotes corrosion, make sure that the slope does not disturb drainage.
 - Keep the floor level so that rain does not accumulate.
 - Be careful not to block the drain hole due to foreign substance.
- Check the condition of the product periodically.
 - Check the installation site every 3 months and perform anti-corrosion treatment such as R-Pro supplied by SAMSUNG (Code : MOK-220SA) or commercial water repellent grease and wax, etc., based on the product condition.
 - When the product is to be shut down for a long period of time, such as off-peak hours, take appropriate measures like covering the product.
- If the product installed within 1640.4 ft of seashore, special anti-corrosion treatment is required.
 - ※ Please contact your local SAMSUNG representative for further details.

CAUTION

- In areas with heavy snow fall, piled snow could block the air intake. To avoid this incident, install a frame that is higher than estimated snow fall. In addition, install a snow-proof hood to avoid snow from piling on the outdoor unit.

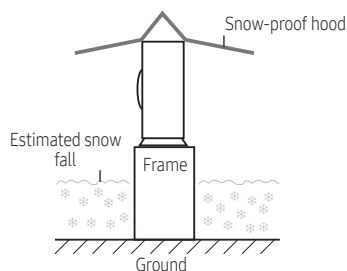

Outdoor unit dimensions

Unit : inch (mm)

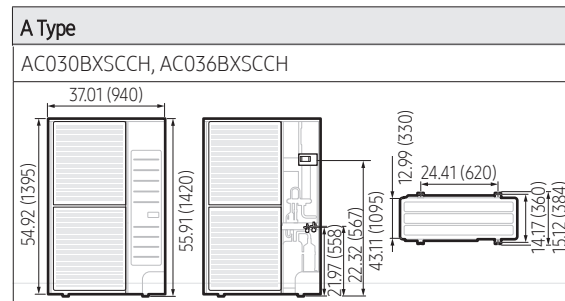

Installation

Outdoor Units

Minimum clearances for the outdoor unit

When installing 1 outdoor unit

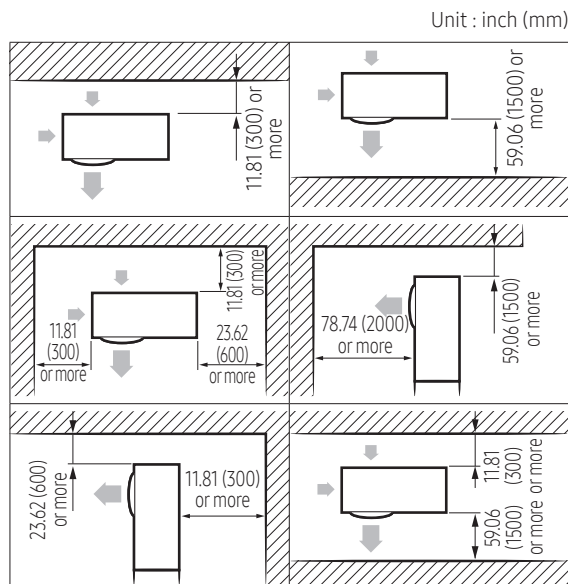

When installing more than 1 outdoor unit

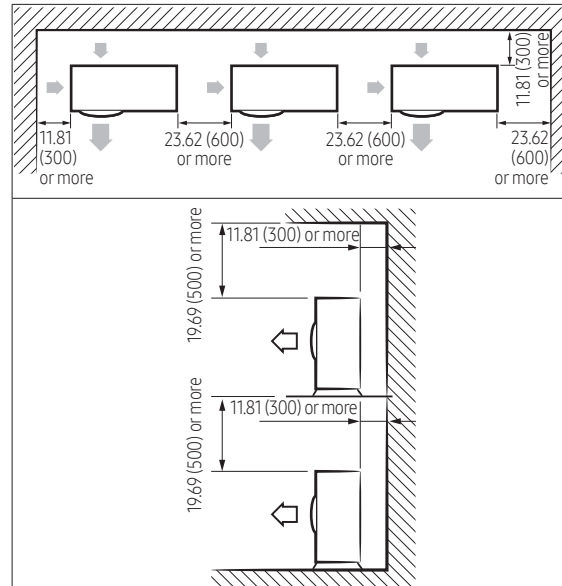
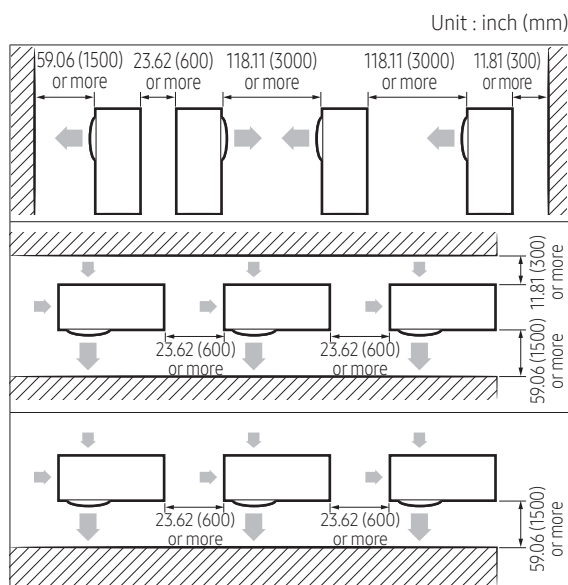

CAUTION

- The outdoor unit must be installed according to the specified distances in order to permit accessibility from each side, to guarantee correct operation, maintenance, and repair of the unit. The components of the outdoor unit must be reachable and removable under safe conditions for people and the unit.

WARNING

- Should adopt bar type louver. Don't use a type of rain resistance louver.

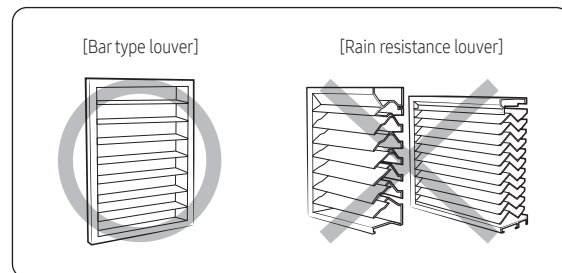

- Louver specifications.
 - Angle criteria : less than 20°
 - Opening ratio criteria : greater than 80%

Installation

Outdoor Units

Moving the outdoor unit with wire rope

- 1 Before carrying the outdoor unit, fasten two wire ropes of 26.25 ft (8m) or longer, as shown in the figure.
- 2 To prevent damages or scratches effectively, insert a piece of cloth between the outdoor unit and the ropes.
- 3 Move the outdoor unit.

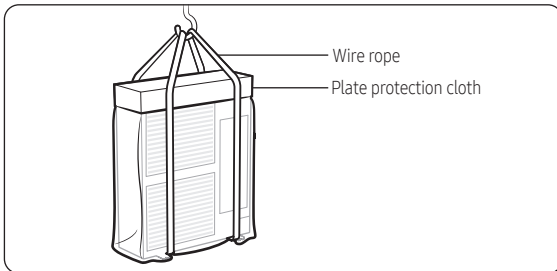
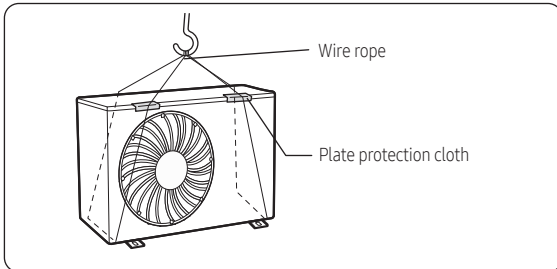

Fixing the outdoor unit in place

Install the outdoor unit on a rigid and stable base to prevent disturbance from any noise caused by vibration. When installing the unit on tall stands or in a location exposed to strong winds, fix the unit securely to the ground or structure.

- 1 Position the outdoor unit so that the air flow is directed towards the outside, as indicated by the arrows on the top of the unit.
- 2 Attach the outdoor unit to the appropriate support using anchor bolts.
 - The ground wire for the telephone line cannot be used to ground the air conditioner.
- 3 If the outdoor unit is exposed to strong winds, install shield plates around the outdoor unit, so that the fan can operate correctly.

NOTE

- Install provided rubber legs to prevent vibration and noise.

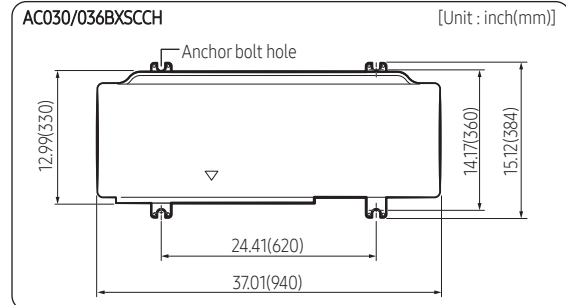

CAUTION

- Install a drain outlet at the lowest end around the base for outdoor unit drainage
- When installing the outdoor unit on the roof, waterproof the unit and check the ceiling strength.

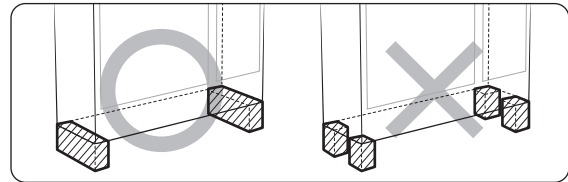

Optional: Fixing the outdoor unit to a wall with a rack

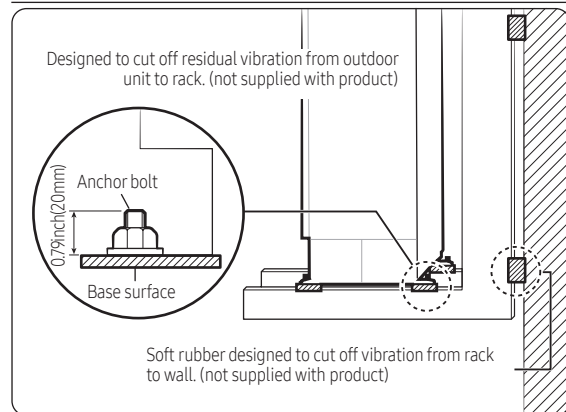

- Install a proper grommet in order to reduce noise and residual vibration transferred by the outdoor unit towards the wall.

Installation

Outdoor Units

CAUTION

- Make sure that the wall can support the weights of the rack and the outdoor unit.
- Install the rack close to the column as much as possible.
- When installing an air guide duct, be sure to check the following:
 - The screws do not damage the copper pipe.
 - The air guide duct is fixed firmly on the guard fan.

Connecting the power cables, communication cable, and controllers

You must connect the following three electrical cables to the outdoor unit:

- The main power cable between the auxiliary circuit breaker and the outdoor unit.
- The outdoor-to-indoor power cable between the outdoor unit and the indoor unit.
- The communication cable between the outdoor unit and the indoor unit.

CAUTION

- During installation, make first the refrigerant connections and then the electrical connections. If the unit is being removed, first disconnect the electrical cables and then the refrigerant connections.
- Connect the air conditioner to the earthing system before making the electrical connections.

Connecting wire conduits

When connecting cables between the indoor unit and the outdoor unit, use conduits to protect the cables.

- 1 Drill holes on the conduit plate in accordance with their use and quantity.

- AC030/036BXSCCH
 - Use a nipper to remove conduit holes from the lower part of the cabinet.
(Do not remove it by hammering.)

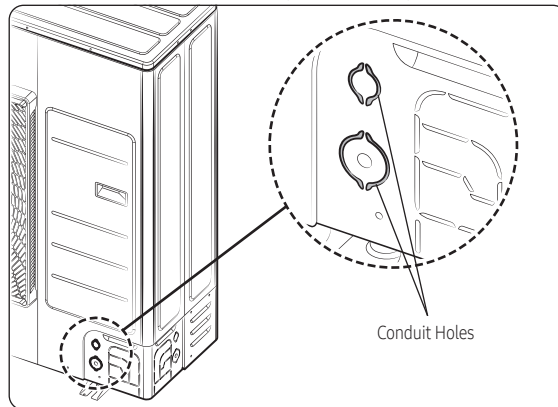

Installation

Outdoor Units

- 2 Insert the cables through the conduits, and then fix the conduits to the conduit plate with the lock nuts.
- 3 Apply silicone to the end of the hose to prevent rain from entering the hose.

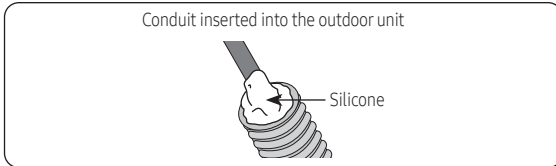

- 4 Connect the cables to the outdoor units.
For how to connect the cables, refer to the next page.
- 5 Attach the conduit plate to the product.

Air conditioning system examples

When using earth leakage circuit breaker (ELCB) for a single phase

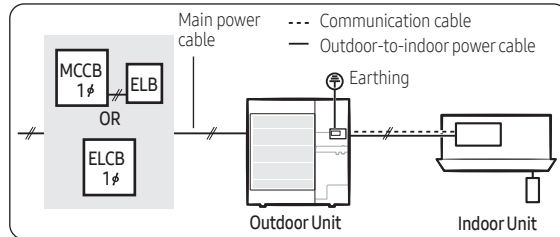
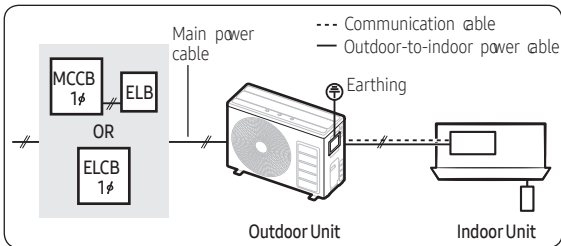

※ The appearance of the unit may be different from the picture depending on the model.

CAUTION

- If the outdoor unit is installed in a location vulnerable to an electric leak or submergence, make sure to install an ELCB.
- AC030/036BXSCCH : ELCB must be installed since this product is equipped with a base heater.

Installation

Outdoor Units

Connecting the main power cable

When using ELB for AC030/036BXSCCH (1-phase)

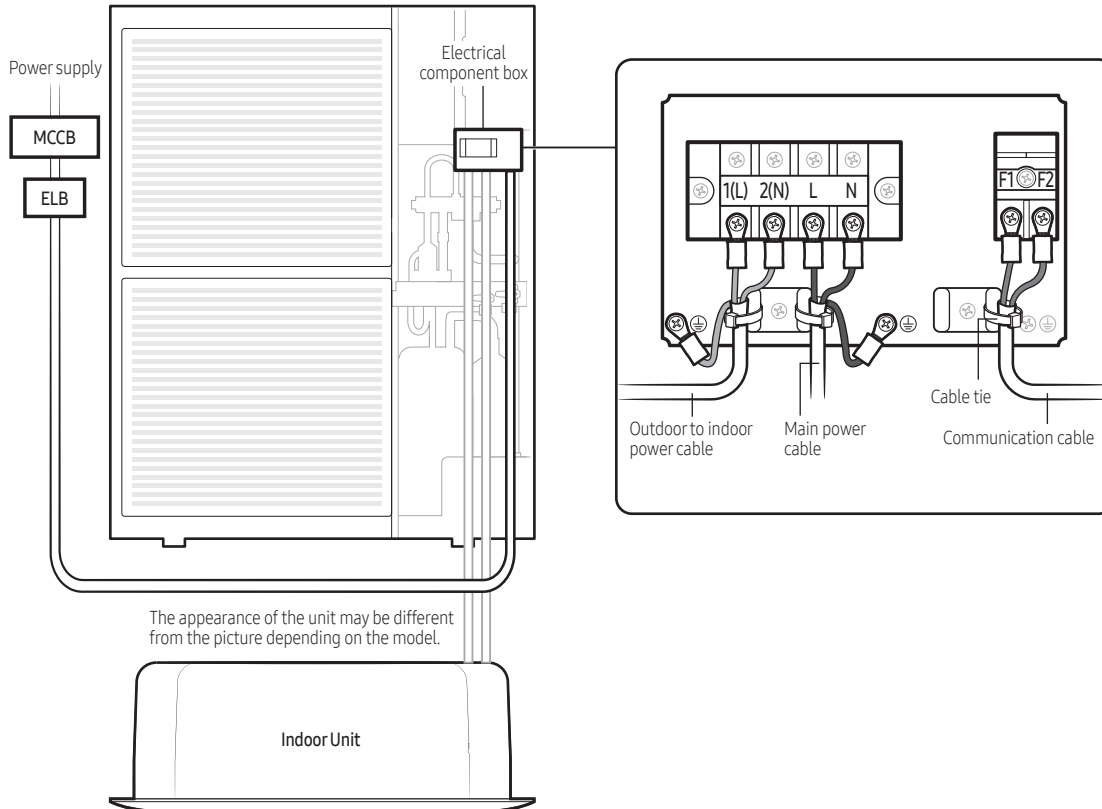

Installation

Outdoor Units

⚠ CAUTION

- You should connect the power cable into the power cable terminal and fasten it with a clamp.
- The unbalanced power must be maintained within 2% of supply rating.
- If the power is unbalanced greatly, it may shorten the life of the condenser. If the unbalanced power is exceeded over 4% of supply rating, the indoor unit is protected, stopped and the error mode indicates.
- To protect the product from water and possible shock, you should keep the power cable and the connection cord of the indoor and outdoor units within ducts. (with appropriate IP rating and material selection for your application)
- Ensure that main supply connection is made through a switch that disconnects all poles, with contact gap of a least 0.12 inch(3mm).
- Devices disconnected from the power supply should be completely disconnected in the condition of overvoltage category.
- Keep distances of 1.97 inch(50mm) or more between power cable and communication cable.

Main power terminal block specifications

[Unit : inch(mm)]

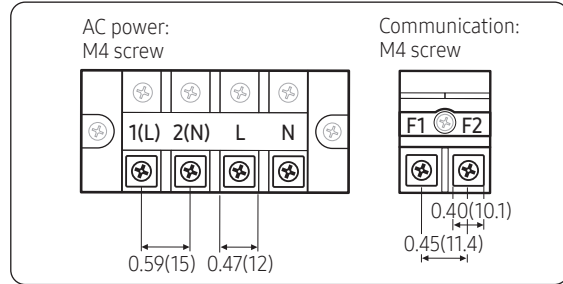

Main power cable specifications

The power cable is not supplied with air conditioner.

- Select the power supply cable in accordance with relevant local and national regulations.
- Wire size must comply with the applicable local and national code.
- Specifications for local wiring power cord and branch wiring are in compliance with local cord.

Single phase

Model		Power Source	RLA (A)	Outdoor		Indoor	MCA (A)	MOP (A)
Outdoor	Indoor			MOC		Rated input current of the power conversion equipment		
				FAN1(A)	FAN2(A)	FAN(A)		
AC030BXSCH	AC030BN4DCH	208~230V/60Hz	21.0	1.25	1.25	0.79	32.1	40.0
	AC030BNHDCH					2.10		
	AC030BNZDCH					2.50		
	AC030KNZDCH					1.66		
AC036BXSCH	AC036BN4DCH		21.0	1.25	1.25	0.79	33.2	40.0
	AC036BNHDCH					3.50		
	AC036BNZDCH					3.60		
	AC036KNZDCH					1.66		

Installation

Outdoor Units

NOTE

- RLA is based on AHRI 210/240 cooling standard condition [Indoor temp. : 26.7 °C / 80 °F(DB) / 19.46 °C / 67 °F(WB), Outdoor temp. : 35 °C / 95 °F(DB)]
- Voltage tolerance is $\pm 10\%$.
- Maximum allowable voltage between phases is 2 %.
- **Symbols**
 - RLA: Rated Load Ampere (A)
 - MOC: Maximum Operating Current (A)
 - MCA: Minimum Circuit Ampere (A)
 - MOP: Maximum Overcurrent Protective Device (A)
- Voltage range
 - Units are suitable for use on electrical systems where voltage supplied to unit terminal is not below or above listed range limits.
- Maximum allowable voltage variation between phases is 2%.
- Wire size & type must comply with the applicable local and national code.
 - Wire size: Based on the value of MCA.
 - Wire type:
 - 1-phase: 60245 IEC57(IEC) or H05RN-F(CENELEC) grade or more

Silence mode controller wiring diagram with External controller

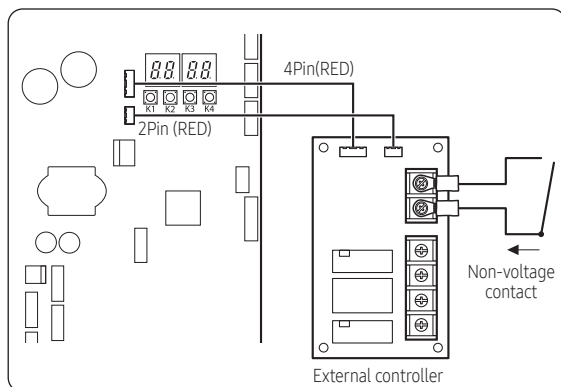

Connecting the outdoor-to-indoor power cable and the communication cable

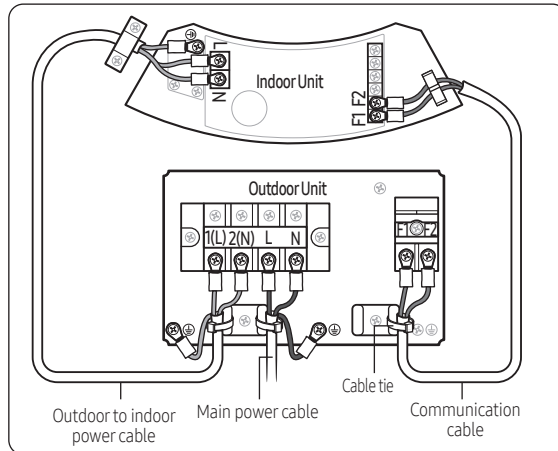

NOTE

- Lay the electrical wiring so that the front cover does not rise up when doing wiring work and attach the front cover securely.
- Ground wire for the indoor unit and outdoor unit connection cable must be clamped to a soft copper tin-plated eyelet terminal with M4 screw hole (NOT SUPPLIED WITH UNIT ACCESSORIES).
- The appearance of the unit may be different from the picture depending on the model.

Outdoor-to-indoor power terminal specifications

- Connect the cables to the terminal board using the compressed ring terminal.
- Cover a solderless ring terminal and a connector part of the power cable and then connect it.

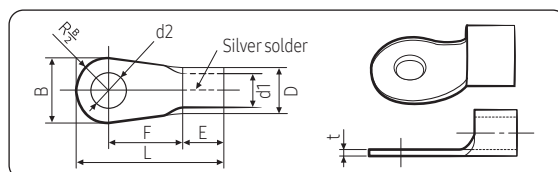

Installation

Outdoor Units

Nominal dimensions for cable [mm2(inch2)]	Nominal dimensions for screw [mm(inch)]	B		D		d1		E [mm (inch)]	F [mm (inch)]	L [mm (inch)]	d2		t [mm (inch)]
		Standard dimension [mm(inch)]	Allowance [mm(inch)]	Standard dimension [mm(inch)]	Allowance [mm(inch)]	Standard dimension [mm(inch)]	Allowance [mm(inch)]				Standard dimension [mm(inch)]	Allowance [mm(inch)]	
4/6 (0.006/ 0.009)	4(3/8)	9.5(3/8)	±0.2 (±0.007)	5.6(1/4)	+0.3(+0.011) -0.2(-0.007)	3.4(1/8)	±0.2 (±0.007)	6 (1/4)	5 (3/16)	20 (3/4)	4.3 (3/16)	+0.2 (+0.007) 0(0)	0.9 (0.03)
	8(3/16)	15(9/16)									28.5 (1-1/8)	8.4 (1-3/16)	
10(0.01)	8(3/16)	15(9/16)	±0.2 (±0.007)	7.1(1/4)	+0.3(+0.011) -0.2(-0.007)	4.5(3/16)	±0.2 (±0.007)	7.9 (5/16)	9 (3/8)	30 (1-3/16)	8.4 (1-3/16)	+0.4 (+0.015) 0(0)	1.15 (0.04)
16(0.02)	8(3/16)	16(10/16)	±0.2 (±0.007)	9(3/8)	+0.3(+0.011) -0.2(-0.007)	5.8(1/4)	±0.2 (±0.007)	9.5 (5/16)	13 (1/2)	33 (1-5/16)	8.4 (1-3/16)	+0.4 (+0.015) 0(0)	1.45 (0.05)
25(0.03)	8(3/16)	12(1/2)	±0.3 (±0.011)	11.5(7/16)	+0.5(+0.019) -0.2(-0.007)	7.7(5/16)	±0.2 (±0.007)	11 (3/8)	15 (5/8)	34 (1- 3/8)	8.4 (1-3/16)	+0.4 (+0.015) 0(0)	1.7 (0.06)
	8(3/16)	16.5(10/16)							13 (1/2)	8.4 (1-3/16)			
35(0.05)	8(3/16)	16(10/16)	±0.3 (±0.011)	13.3(1/2)	+0.5(+0.019) -0.2(-0.007)	9.4(3/8)	±0.2 (±0.007)	12.5 (1/2)	13 (1/2)	38 (1-1/2)	8.4 (1-3/16)	+0.4 (+0.015) 0(0)	1.8 (0.07)
	8(3/16)	22(7/8)							13 (1/2)	43 (1- 11/16)	8.4 (1-3/16)		
50(0.07)	8(3/16)	22(7/8)	±0.3 (±0.011)	13.5(1/2)	+0.5(+0.019) -0.2(-0.007)	11.4(7/16)	±0.3 (±0.011)	17.5 (11/16)	14 (9/16)	50 (2)	8.4 (1-3/16)	+0.4(+0.015) 0(0)	1.8 (0.07)
70(0.10)	8(3/16)	24(1)	±0.4 (±0.015)	17.5(11/16)	+0.5(+0.019) -0.4(-0.015)	13.3(1/2)	±0.4 (±0.015)	18.5 (3/4)	20 (3/4)	51 (2)	8.4 (1-3/16)	+0.4(+0.015) 0(0)	2.0 (0.078)

- Connect the rated cables only.
- Connect using a driver which is able to apply the rated torque to the screws.
- If the terminal is loose, fire may occur caused by arc. If the terminal is connected too firmly, the terminal may be damaged.

	Tightening torque	
	lbf•ft	N•m
M4	0.87 to 1.30	0.8 to 1.2
M5	1.45 to 2.17	2.0 to 3.0

CAUTION

- When connecting cables, you can connect the cables to the electrical part or connect them through the holes below depending on the spot.
- Connect the communication cable between the indoor and outdoor units through a conduit to protect against external forces, and feed the conduit through the wall together with refrigerant piping.
- Remove all burrs at the edge of the knock-out hole and secure the cable to the outdoor knock-out using lining and bushing with an electrical insulation such as rubber and so on.
- Must keep the cable in a protection tube.
- Keep distances of 1.97 inch(50mm) or more between power cable and communication cable.
- When the cables are connected through the hole, remove the Plate bottom.

Installation

Outdoor Units

Outdoor-to-indoor power and communication cables specifications

- Indoor unit :
4WAY CST(AC***BN4***)

Indoor power supply		
Power supply	Max/Min (V)	Indoor power cable
1Φ, 208-230V~, 60Hz	±10%	0.0012 inch ² ↑ (0.75mm ² ↑), 3wires
Communication cable		
0.0012 inch ² ↑ (0.75mm ² ↑), 2wires		

- Duct(AC***BNL***, AC***BNH***)

Indoor power supply		
Power supply	Max/Min (V)	Indoor power cable
1Φ, 208-230V~, 60Hz	±10%	0.0023 inch ² ↑ (1.5mm ² ↑), 3 wires
Communication cable		
0.0012 inch ² ↑ (0.75mm ² ↑), 2 wires		

- MPAH(AC***NZ***)

Indoor power supply		
Power supply	Max/Min (V)	Indoor power cable
1Φ, 208-230V~, 60Hz	±10%	0.0039 inch ² ↑ (2.5mm ² ↑), 3 wires
Communication cable		
0.0012 inch ² ↑ (0.75mm ² ↑), 2wires		

- Power supply cords of parts of appliances for outdoor use shall not be lighter than polychloroprene sheathed flexible cord. (Code designation IEC:60245 IEC 57 / CENELEC: H05RN-F)
- When installing the indoor unit in a computer room or network room, use the double shielded (tape aluminum / polyester braid + copper) cable of FROHH2R type.

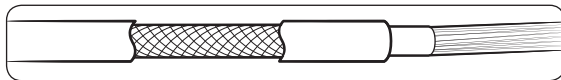



2022.12
Ver.1.0

Samsung Electronics Co., LTD.

Head Office (Suwon Korea) 129, Samsung-Ro, Yeongtong-Gu, Suwon City, Gyeonggi-Do, Korea 16677
Website : www.samsung.com, <https://partnerhub.samsung.com> Email : airconditioner@samsung.com
Images and data in this book may subject to change without prior notice.