



## Ruud Choice™ Series Air Conditioners



### WA14 Series

14 SEER/11.5 EER

Nominal Sizes 1.5-5 Tons [5.28-17.6 kW]



*"Proper sizing and installation of equipment is critical to achieve optimal performance. Split system air conditioners and heat pumps must be matched with appropriate coil components to meet Energy Star. Ask your Contractor for details or visit [www.energystar.gov](http://www.energystar.gov)."*

- Outdoor air conditioner designed for ground level or rooftop installations. These units offer comfort and dependability for single, multi-family and light commercial applications.
- Painted louvered steel cabinet
- Easily accessible control box

- Condenser coils constructed with copper tubing and enhanced aluminum fins
- Grille/Motor mount for quiet fan operation
- Filter Drier (shipped – not installed)

# TABLE OF CONTENTS

Model Number Identification .....	3
Available SKUs .....	3
Electrical & Physical Data .....	4
Weighted Sound Power .....	4
Unit Dimensions .....	5
Refrigerant Line Size Information .....	6-7
Performance Data .....	8
Limited Warranty .....	9

# Air Conditioners\*

<u>W</u>	<u>A</u>	<u>13</u>	<u>24</u>	<u>A</u>	<u>J</u>	<u>1</u>	<u>N</u>	<u>A</u>
Brand	Product Category	SEER	Capacity BTU/HR	Major Series*	Voltage	Type	Controls	Minor Series**
Ruud	A - Air Conditioners	14 - 14 SEER	18 - 18,000 [5.28 kW] 24 - 24,000 [7.03 kW] 30 - 30,000 [8.79 kW] 36 - 36,000 [10.55 kW] 42 - 42,000 [12.31 kW] 48 - 48,000 [14.07 kW] 60 - 60,000 [17.58 kW]	A - 1st Design B - 2nd Design C - 3rd Design	J - 1ph, 208-230/60	1 - Single-stage	N - Non-Communicating	A - 1st Design

[ ] Designates Metric Conversions

## Available SKUs

Models
WA1418AJ1NA
WA1424BJ1NA
WA1424CJ1NA
WA1430BJ1NA
WA1436BJ1NA
WA1436CJ1NA
WA1442CJ1NA
WA1448BJ1NA
WA1460AJ1NA

## Electrical and Physical Data

<b>Physical Data</b>									
Model No.	WA1418A	WA1424B	WA1424C	WA1430B	WA1436B	WA1436C	WA1442C	WA1448B	WA1460A
Nominal Tonnage	1.5	2.0	2.0	2.5	3.0	3.0	3.5	4.0	5.0
<b>Valve Connections</b>									
Liquid Line O.D. – in.	3/8	3/8	3/8	3/8	3/8	3/8	3/8	3/8	3/8
Suction Line O.D. – in.	5/8	3/4	3/4	3/4	3/4	3/4	7/8	7/8	7/8
Refrigerant (R410A) furnished oz. <sup>1</sup>	82	89	85	98	122	128	135	146	228
Compressor Type	Scroll								
<b>Outdoor Coil</b>									
Net face area – Outer Coil	11.1	11.2	13.7	13.7	18.3	21.9	18.3	21.9	21.9
Net face area – Inner Coil	—	—	—	—	—	—	—	—	—
Tube diameter – in.	0.375	3/8	3/8	3/8	3/8	3/8	3/8	3/8	3/8
Number of rows	1	1	1	1	1	1	1	1	2
Fins per inch	22	22	22	22	22	22	22	22	22
<b>Outdoor Fan</b>									
Diameter – in.	18	18	22	22	22	24	22	24	24
Number of blades	2	2	2	2	2	3	3	3	3
Motor hp	1/10	1/10	1/12	1/8	1/5	1/5	1/4	1/5	1/3
CFM	1697	2105	2077	2121	2702	3430	3174	3571	3360
RPM	1100	1075	841	1075	819	850	1075	850	1085
watts	108	148	76	155	149	228	244	235	311
Shipping weight – lbs.	135	131.5	171	144.5	166	201	184	225	274
Operating weight – lbs.	128	124.5	164	137.5	159	194	176	205	254
<b>Electrical Data</b>									
Line Voltage Data (Volts-Phase-Hz)	208/230-1-60	208/230-1-60	208/230-1-60	208/230-1-60	208/230-1-60	208/230-1-60	208/230-1-60	208/230-1-60	208/230-1-60
Maximum overcurrent protection (amps) <sup>2</sup>	20	25	25	25	30	35	35	45	60
Minimum circuit ampacity <sup>3</sup>	13	15	15	17	19	21	23	26	35
<b>Compressor</b>									
Rated load amps	9.7	11.2	11.2	12.8	14.1	15.4	16.7	19.9	26.4
Locked rotor amps	46	60.8	60.8	64	77	84	109	109	134
<b>Condenser Fan Motor</b>									
Full load amps	0.5	0.6	.36	0.7	1.2	1.0	1.3	1	1.7
Locked rotor amps	1.3	1.3	1	1.2	2	2	2.5	2.3	3.2

<sup>1</sup>Refrigerant charge sufficient for 15 ft. length of refrigerant lines. For longer line set requirements see the installation instructions for information about set length and additional refrigerant charge required.

<sup>2</sup>HACR type circuit breaker or fuse.

<sup>3</sup>Refer to National Electrical Code manual to determine wire, fuse and disconnect size requirements.

## Weighted Sound Power Level (dBA)

Model	Standard Rating (dBA)	TYPICAL OCTAVE BAND SPECTRUM (dBA without tone adjustment)							
		125	250	500	1000	2000	4000	8000	
WA1430B	73	50.0	57.8	61.8	64.3	60.4	56.5	54.2	
WA1436B	71	48.8	50.1	58.3	60.9	61.3	56.5	55.7	
WA1436C	73	48.8	56.4	62.1	64.6	60.0	55.9	49.7	
WA1442C	75	50.5	55.1	63.5	67.8	61.7	58.2	52.1	
WA1448B	75	49.6	55.4	63.4	68.7	61.9	58.6	55.8	

## Unit Dimensions

MODEL NUMBER	OPERATING						SHIPPING					
	H (Height)		L (Length)		W (Width)		H (Height)		L (Length)		W (Width)	
	INCHES	mm	INCHES	mm	INCHES	mm	INCHES	mm	INCHES	mm	INCHES	mm
WA1418A	24.25	615	23.63	600	23.63	600	24.25	615	24.75	628	24.75	628
WA1424B	32.25	819	23.63	600	23.63	600	32.50	825	24.75	628	24.75	628
WA1424C	24.25	615	27.63	701	27.63	701	24.25	615	28.75	730	28.75	730
WA1430B	24.25	615	27.63	701	27.63	701	24.25	615	28.75	730	28.75	730
WA1436B	32.25	819	27.63	701	27.63	701	32.50	825	28.75	730	28.75	730
WA1436C	35.38	899	31.63	803	31.63	803	35.63	905	32.75	832	32.75	832
WA1442C	32.25	819	27.63	701	27.63	701	32.50	825	28.75	730	28.75	730
WA1448B	35.38	899	31.63	803	31.63	803	35.56	903	33.94	862	33.94	862
WA1460A	35.38	899	31.63	803	31.63	803	35.56	903	33.94	862	33.94	862

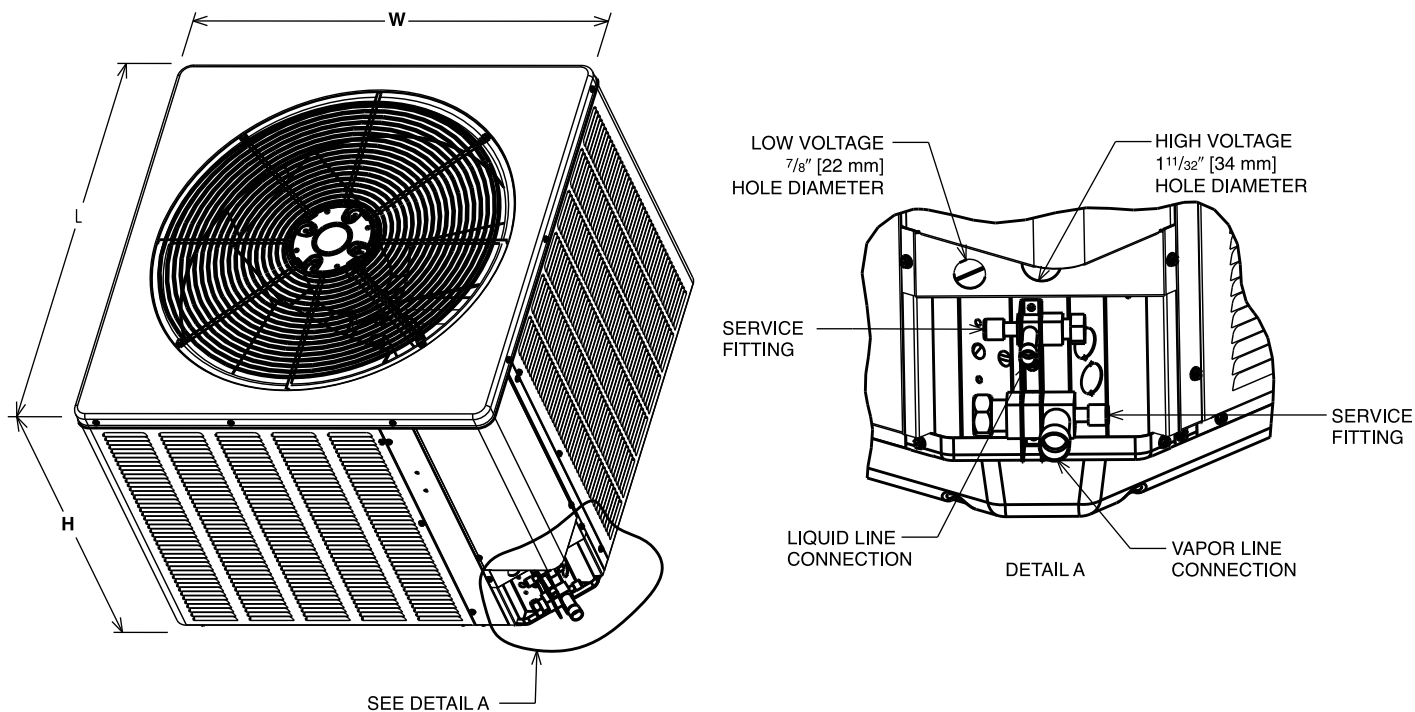

**NOTE:** Illustrations show the deep drawn basepan.

# Air Conditioner Refrigerant Line Size Information

Unit Size	Allowable Liquid Line Size	Allowable Suction Line Size	Apply Long Line Guidelines if Linear Line Length Exceeds Those Shown Below (Feet)		Equivalent Length (Feet)												
			WA13	WA14A/B	WA14W	Maximum Vertical Rise (Outdoor Unit Below Indoor Unit) * / Capacity Multiplier											
						< 25	26-50	51-75	76-100	101-125	126-150	151-175	176-200	201-225	226-250		
1.5 Ton <b>**SEE NOTE 3</b>	1/4"	5/8"	N/A	N/A	N/A	25/1.00	50/0.99	62/0.98	43/0.98	24/0.97	5/0.97	NR	NR	NR	NR	NR	NR
	5/16"	5/8"	225	188	190	25/1.00	50/0.99	75/0.98	98/0.98	93/0.97	88/0.97	83/0.96	78/0.96	73/0.95	68/0.94	63/0.94	58/0.94
	3/8"	5/8"	150	125	127	25/1.00	50/0.99	75/0.98	100/0.98	100/0.97	100/0.97	100/0.96	100/0.96	100/0.95	100/0.95	100/0.94	100/0.94
	1/4"	3/4"	N/A	N/A	N/A	25/1.00	50/1.00	62/0.99	43/0.99	24/0.99	5/0.99	NR	NR	NR	NR	NR	NR
	5/16"	3/4"	225	188	190	25/1.00	50/1.00	75/0.99	98/0.99	93/0.99	88/0.99	83/0.99	78/0.98	73/0.98	68/0.98	63/0.98	58/0.98
	3/8"	3/4"	150	125	127	25/1.00	50/1.00	75/1.00	100/0.99	100/0.99	100/0.99	100/0.99	100/0.99	100/0.98	100/0.98	100/0.98	100/0.98
2 Ton	1/4"	5/8"	N/A	N/A	N/A	25/0.99	50/0.98	21/0.97	NR	NR	NR	NR	NR	NR	NR	NR	NR
	5/16"	5/8"	223	180	180	25/0.99	50/0.98	75/0.97	87/0.96	77/0.95	69/0.94	61/0.93	53/0.92	45/0.91	37/0.90	30/0.90	23/0.90
	3/8"	5/8"	148	120	120	25/0.99	50/0.98	75/0.97	100/0.96	100/0.95	100/0.94	98/0.93	95/0.92	92/0.91	89/0.90	86/0.90	83/0.90
	1/4"	3/4"	N/A	N/A	N/A	25/1.00	50/1.00	21/0.99	NR	NR	NR	NR	NR	NR	NR	NR	NR
	5/16"	3/4"	223	180	180	25/1.00	50/1.00	75/0.99	87/0.99	77/0.98	69/0.98	61/0.98	53/0.97	45/0.97	37/0.96	30/0.96	23/0.96
	3/8"	3/4"	148	120	120	25/1.00	50/1.00	75/0.99	100/0.99	100/0.98	100/0.98	98/0.98	95/0.97	93/0.97	90/0.96	87/0.96	84/0.96
2.5 Ton	5/16"	5/8"	148	148	113	25/0.99	50/0.98	75/0.96	70/0.94	59/0.93	48/0.91	36/0.90	NR	NR	NR	NR	NR
	3/8"	5/8"	98	98	75	25/0.99	50/0.98	75/0.96	100/0.94	98/0.93	94/0.91	90/0.90	NR	NR	NR	NR	NR
	5/16"	3/4"	148	148	113	25/1.00	50/0.99	75/0.99	70/0.98	59/0.98	48/0.97	36/0.96	25/0.96	13/0.95	NR	NR	NR
	3/8"	3/4"	98	98	75	25/1.00	50/0.99	75/0.99	100/0.98	98/0.98	94/0.97	90/0.96	86/0.96	82/0.95	78/0.95	74/0.95	70/0.95
	5/16"	5/8"	N/A	73	73	25/0.99	50/0.97	66/0.94	49/0.92	32/0.90	NR	NR	NR	NR	NR	NR	NR
	3/8"	5/8"	110	48	48	25/0.99	50/0.97	75/0.94	95/0.92	89/0.90	NR	NR	NR	NR	NR	NR	NR
3 Ton	5/16"	3/4"	N/A	73	73	25/1.00	50/0.99	66/0.98	49/0.98	32/0.97	15/0.96	NR	NR	NR	NR	NR	NR
	3/8"	3/4"	110	48	48	25/1.00	50/0.99	75/0.98	95/0.98	89/0.97	84/0.96	78/0.95	72/0.94	67/0.93	61/0.93	56/0.93	51/0.93
	1/2"	3/4"	55	24	24	25/1.00	50/0.99	75/0.98	100/0.98	100/0.97	100/0.96	100/0.95	100/0.94	100/0.93	100/0.93	100/0.93	100/0.93
	5/16"	7/8"	N/A	73	73	25/1.00	50/1.00	66/1.00	49/0.99	32/0.99	15/0.99	NR	NR	NR	NR	NR	NR
	3/8"	7/8"	110	48	48	25/1.00	50/1.00	75/1.00	95/0.99	89/0.99	84/0.99	78/0.98	72/0.98	67/0.98	61/0.97	56/0.97	51/0.97
	1/2"	7/8"	55	24	24	25/1.00	50/1.00	75/1.00	100/0.99	100/0.99	100/0.99	100/0.99	100/0.98	100/0.98	100/0.98	100/0.98	100/0.97
3.5 Ton	3/8"	3/4"	148	100	100	25/0.99	50/0.98	75/0.97	88/0.96	80/0.95	72/0.94	65/0.92	57/0.91	49/0.90	NR	NR	NR
	1/2"	3/4"	74	50	50	25/0.99	50/0.98	75/0.97	100/0.96	100/0.95	100/0.94	100/0.92	100/0.91	100/0.90	NR	NR	
	3/8"	7/8"	148	100	100	25/1.00	50/1.00	75/0.99	88/0.99	80/0.99	72/0.98	65/0.97	57/0.97	49/0.96	42/0.96	35/0.96	28/0.96
	1/2"	7/8"	74	50	50	25/1.00	50/1.00	75/0.99	100/0.99	100/0.99	100/0.99	100/0.98	100/0.97	100/0.96	100/0.96	100/0.96	100/0.96
	3/8"	3/4"	82	82	0	25/0.99	50/0.98	75/0.96	77/0.95	67/0.93	57/0.92	46/0.91	NR	NR	NR	NR	NR
	1/2"	3/4"	41	41	0	25/0.99	50/0.98	75/0.96	100/0.95	100/0.93	100/0.92	100/0.91	NR	NR	NR	NR	NR
4 Ton	3/8"	7/8"	82	82	0	25/1.00	50/0.99	75/0.99	77/0.98	67/0.97	57/0.97	46/0.96	36/0.96	26/0.95	15/0.95	NR	NR
	1/2"	7/8"	41	41	0	25/1.00	50/0.99	75/0.99	100/0.98	100/0.97	100/0.97	100/0.96	100/0.96	99/0.95	97/0.95	95/0.95	93/0.95
	3/8"	3/4"	0	0	0	25/0.99	50/0.97	75/0.94	61/0.92	46/0.90	NR	NR	NR	NR	NR	NR	NR
	1/2"	3/4"	0	0	0	25/0.99	50/0.97	75/0.94	100/0.92	100/0.90	NR	NR	NR	NR	NR	NR	NR
	3/8"	7/8"	0	0	0	25/1.00	50/0.99	75/0.98	61/0.97	46/0.96	32/0.95	18/0.94	NR	NR	NR	NR	NR
	1/2"	7/8"	0	0	0	25/1.00	50/0.99	75/0.98	100/0.97	100/0.96	100/0.95	97/0.94	95/0.94	92/0.93	89/0.92	86/0.92	83/0.92
5 Ton	3/8"	1-1/8"	0	0	0	25/1.01	50/1.01	75/1.00	61/1.00	46/0.99	32/0.99	18/0.99	NR	NR	NR	NR	NR
	1/2"	1-1/8"	0	0	0	25/1.01	50/1.01	75/1.00	100/1.00	100/0.99	100/0.99	100/0.99	100/0.99	100/0.99	100/0.99	100/0.99	100/0.99
	3/8"	3/4"	0	0	0	25/0.99	50/0.97	75/0.94	61/0.92	46/0.90	NR	NR	NR	NR	NR	NR	NR
	1/2"	3/4"	0	0	0	25/0.99	50/0.97	75/0.94	100/0.92	100/0.90	NR	NR	NR	NR	NR	NR	NR
	3/8"	7/8"	0	0	0	25/1.00	50/0.99	75/0.98	61/0.97	46/0.96	32/0.95	18/0.94	NR	NR	NR	NR	NR
	1/2"	7/8"	0	0	0	25/1.00	50/0.99	75/0.98	100/0.97	100/0.96	100/0.95	97/0.94	95/0.94	92/0.93	89/0.92	86/0.92	83/0.92

**NOTES:**  
 1. Do not exceed 200 ft linear line length.  
 2. \*Do not exceed 100 ft vertical separation if outdoor unit is above indoor unit.  
 3. \*\*3/4" suction line should only be used for 1.5 ton systems if outdoor unit is below or at same level as indoor to assure proper oil return.  
 4. Always use the smallest liquid line allowable to minimize refrigerant charge.  
 5. Applications shaded in light gray indicate capacity multipliers between 0.90 and 0.96 which are not recommended, but are allowed.  
 6. Applications shaded in dark gray are not recommended due to excessive liquid or suction pressure drop.



## Performance Data @ AHRI Standard Conditions—Cooling

Designated Tested Combination (DTC)										
Outdoor Unit	Indoor Coil or Air Handler	Total Capacity BTU/H [kW]		Net Sensible BTU/H [kW]		Net Latent BTU/H [kW]		SEER	EER	Indoor CFM [L/s]
WA1418AJ1	TCF2417STA	17100	[5.0]	13300	[3.9]	4700	[1.4]	14.00	11.50	600 [283.2]
WA1424BJ1	TCF2417MTA	22800	[8.7]	18000	[5.3]	6000	[1.8]	14.00	11.00	800 [377.6]
WA1436CJ1	TCF3621STA	34200	[10.0]	24500	[7.2]	9700	[1.8]	14.00	11.00	1125 [530.9]
WA1430BJ1	TCF3617STA	28600	[8.4]	21700	[6.4]	6900	[2.0]	14.00	11.50	1000 [471.9]
WA1436BJ1	TCF3621MTA	34200	[10.0]	24500	[7.2]	9700	[2.8]	14.00	11.50	1100 [519.1]
WA1442C	TCF4821MTA	40500	[11.9]	31000	[9.1]	9500	[2.8]	14.00	11.50	1350 [637.1]
WA1448BJ1	TCF4821STA	46000	[13.5]	34800	[10.2]	11200	[3.3]	14.00	11.50	1500 [707.9]
WA1460A	TCF6024STA	59000	[17.29]	34800	[11.25]	20600	[6.04]	14.00	11.50	1600 [755.1]

**Note:** Additional ratings and system match ups and downloadable ratings certificates can be accessed from the AHRI website: [www.ahridirectory.org](http://www.ahridirectory.org)

[ ] Designates Metric Conversions



**GENERAL TERMS OF LIMITED WARRANTY\***

Ruud will furnish a replacement for any part of this product which fails in normal use and service within the applicable period stated, in accordance with the terms of the limited warranty.

Parts.....Five (5) Years

**\*For complete details of the Limited and Conditional Warranties, including applicable terms and conditions, contact your local contractor or the Manufacturer for a copy of the product warranty certificate.**







*In keeping with its policy of continuous progress and product improvement, Ruud reserves the right to make changes without notice.*

Ruud Heating, Cooling & Water Heating • 5600 Old Greenwood Road  
Fort Smith, Arkansas 72908 • [www.ruud.com](http://www.ruud.com)

Ruud Canada • 125 Edgeware Road, Unit 1  
Brampton, Ontario • L6Y 0P5

**RELY ON RUUD.™**