



The new degree of comfort.™



Rheem *Commercial Classic*® Series Package Heat Pump



*Unit shown with optional louver panels installed.

RJPL-A 14 SEER High Efficiency Series Nominal Sizes 3-5 Tons [10.6-17.6 kW]



TABLE OF CONTENTS

Unit Features & Benefits	3-4
Model Number Identification	5
Options	6
Selection Procedure	7
General Data	
RJPL- Series	8-14
General Data Notes	15
Gross Systems Performance Data	
RJPL- Series	16-19
Airflow Performance	
RJPL- Series	20-22
Electrical Data	
RJPL- Series	23-24
Electric Heater Kits	
RJPL- Series	25-31
Dimensional Data	32-34
Accessories	35-43
Mechanical Specifications	44-48
Limited Warranty	49



Air

Package Heat Pump Features:

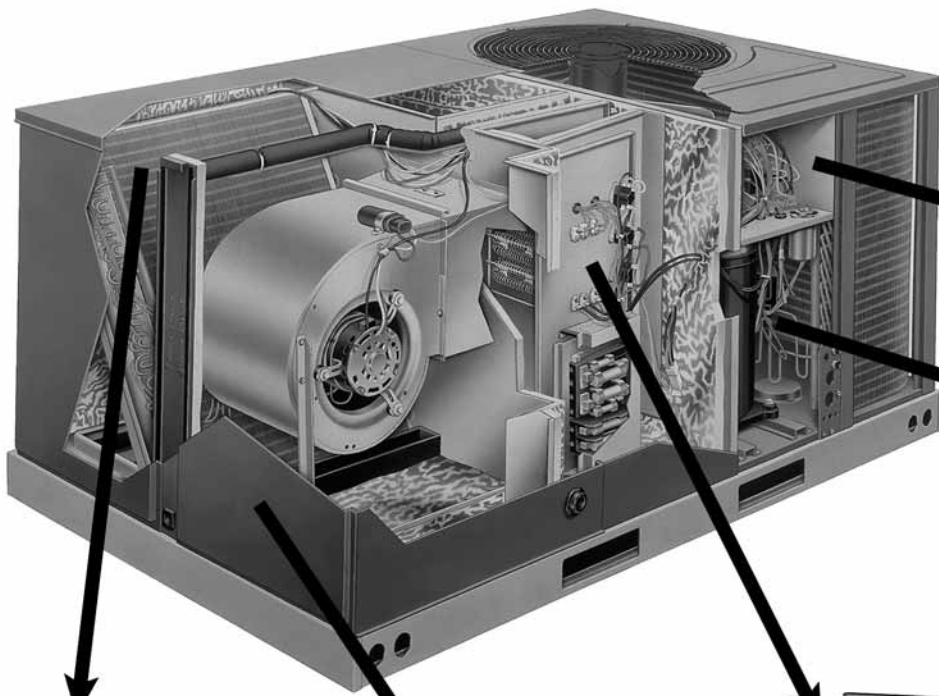

Control Box Access



Compressor Access



Evaporator Coil/Filter Access

Blower Access

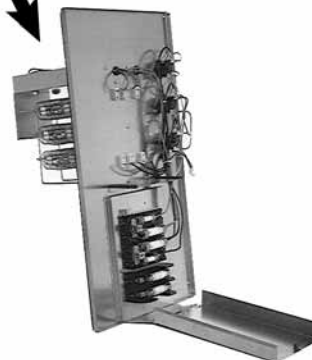

Optional Electric Heater Kit



RJPL - A036, A042, A048, A060

RJPL-A STANDARD FEATURES INCLUDE:

- R-410A HFC refrigerant.
- Complete factory charged, wired and run tested.
- Scroll compressors with internal line break overload and high-pressure protection.
- Single stage compressor on all models.
- Convertible airflow.
- TXV refrigerant metering system on each circuit.
- High Pressure protection standard on all models. Low Pressure/Loss of charge protection standard on 6 ton model.
- Solid Core liquid line filter drier on each circuit.
- Single slab, single pass designed evaporator coil facilitate easy cleaning for maintained high efficiencies.
- Cooling operation up to 125 degree F ambient.
- Easy access to filter, blower, electric heat, and compressor/control compartments permit prompt service.
- One piece top cover and one piece base pan with drawn supply and return opening for superior water management.
- Externally mounted refrigerant gauge ports for easy service diagnostics.
- Easy to install plug-in; slip in, 100% fully modulating economizer with barometric relief.
- Forkable base rails for easy handling and lifting.
- Single point electrical connection.
- Direct drive or high performance belt drive motor with variable pitch pulleys and quick adjust belt system.
- Permanently lubricated evaporator and condenser motors.
- Condenser motors are internally protected, totally enclosed with shaft down design.
- 1 inch filter standard with slide out design.
- Colored and labeled wiring.
- Copper tube/Aluminum Fin coils.
- Molded compressor plug.
- Supplemental electric heat provides 100% efficient heating.



R J P L - A 036 J K 000 X X X

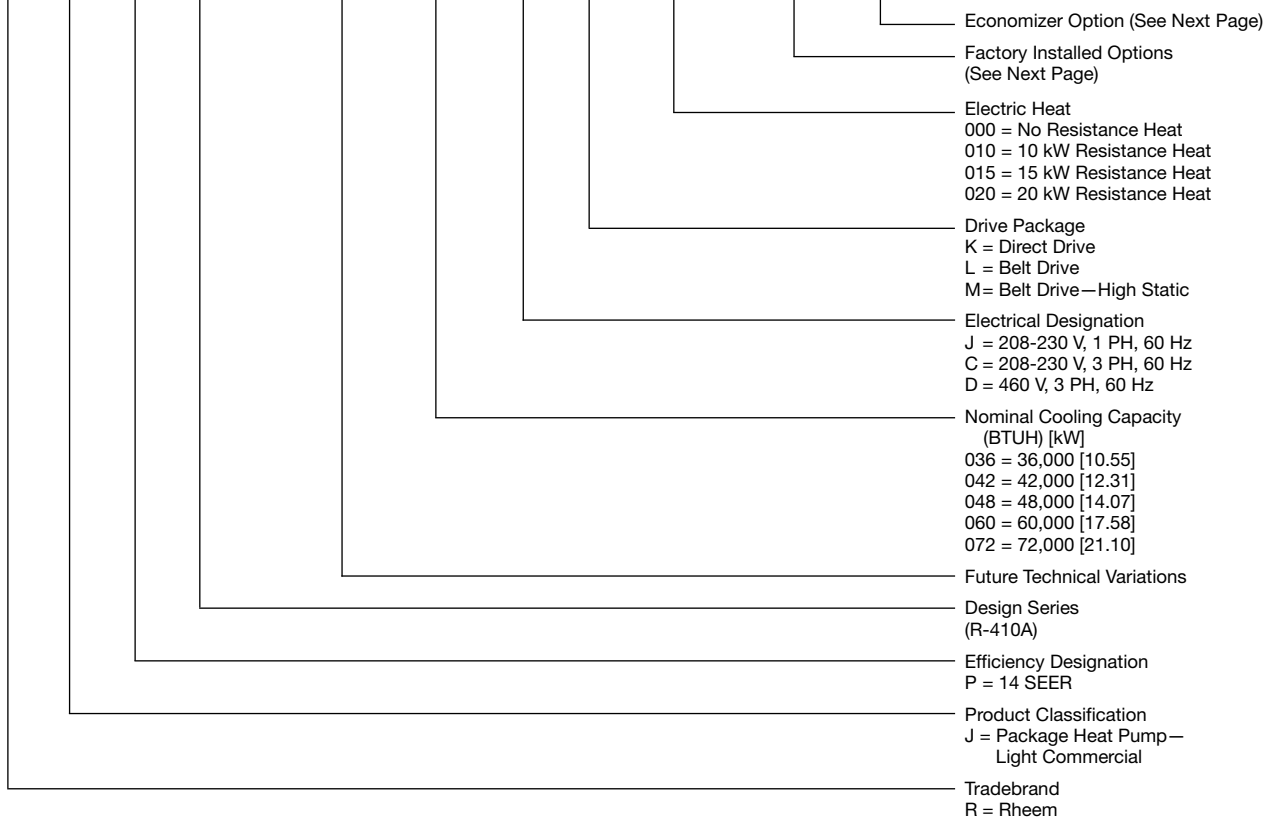

[] Designates Metric Conversions

FACTORY INSTALLED OPTION CODES FOR RJPL- (3-5 Ton) [10.6-17.6 kW] (A036, A048, A060)

Option Code	Hail Guard	Non-Powered Conv. Outlet	Low Ambient/ Freeze Stat	Hinged Doors
AA	NO OPTIONS			
AD	X			
AG		X		
AP			X	
AV				X
BY	X		X	
BJ	X	X		
JC		X	X	
JK	X			X
JL		X		X
JP			X	X
CX	X	X	X	
KD	X	X		X
KG	X		X	X
KK		X	X	X
DS	X	X	X	X

Example: RJPL-A060JK000XX (where XX is factory installed option)

Example: No Options

RJPL-A060JK000

Example: No Options with Factory Installed Economizer

RJPL-A060JK000AAF

Example: Options with Hailguard with no Factory Installed Economizer

RJPL-A060JK000ADA

Example: Options same as above with Factory Installed Economizer

RJPL-A060JK000ADF

ECONOMIZER SELECTION FOR RJPL- (3-5 Ton) [10.6-17.6 kW] (A036, A048, A060)

Option Code	No Economizer	Economizer No Smoke Detector	Economizer With Smoke Detector
A	X		
F		X	
G			

"X" indicates factory installed option.

[] Designates Metric Conversions

SELECTION PROCEDURE

1. Determine cooling and heating requirements at design conditions.

Example:

Total cooling capacity43,600 BTUH [12.78 kW]
Sensible cooling capacity34,000 BTUH [9.96 kW]
Condenser entering air.....95°F [35°C]
Evaporator entering air.....63°F [17°C] wb/76°F [24°C] db
Indoor air flow.....1600 CFM [755 L/s]
External static pressure1.1 in wg
Required efficiency.....13 SEER

2. Select unit to meet cooling requirements.

Since total cooling is within the range of 4 ton [14.07 kW] unit and requires 13 SEER efficiency level, enter cooling performance table, at 95°F [35°C] outdoor temperature, 63°F [17°C] wb entering indoor air, and 1600 CFM [755 L/s]:

Total capacity 46,700 BTUH [13.68 kW]
Power input 3.3 kW

And also, at 76°F [24°C] db indoor entering air, and using the formula at the bottom of the page:

Sensible capacity 33,710 BTUH [9.87 kW]

3. Determine blower speed and power to meet the system requirements.

At the given external static pressure of 1.1 in wg, the belt model must be selected. Enter the belt drive blower performance table at 1600 CFM [755 L/s] and 1.1 in wg ESP:

RPM	1205
Watts	725
Drive	M

4. Calculate indoor blower BTUH heat effect.

BTUH = Watts x 3.413 = 2474

5. Calculate net cooling capacities.

Net total cooling = 46,700 – 2474 = 44,226 BTUH [12.96 kW]

Net sensible cooling = 33,716 – 2474 = 31,242 BTUH [9.16 kW]

[] Designates Metric Conversions

NOMINAL SIZES 3-5 TONS [10.6-17.6 kW]

Model RJPL- Series	A036CK	A036CL	A036CM	A036DK
Cooling Performance¹				CONTINUED →
Gross Cooling Capacity Btu [kW]	37,800 [11.08]	38,500 [11.28]	38,500 [11.28]	37,800 [11.08]
EER/SEER ²	12/14	12/14	12/14	12/14
Nominal CFM/AHRI Rated CFM [L/s]	1200/1200 [566/566]	1200/1200 [566/566]	1200/1200 [566/566]	1200/1200 [566/566]
AHRI Net Cooling Capacity Btu [kW]	36,800 [10.78]	36,800 [10.78]	36,800 [10.78]	36,800 [10.78]
Net Sensible Capacity Btu [kW]	27,200 [7.97]	27,200 [7.97]	27,200 [7.97]	27,200 [7.97]
Net Latent Capacity Btu [kW]	9,600 [2.81]	9,600 [2.81]	9,600 [2.81]	9,600 [2.81]
Net System Power kW	2.99	2.99	2.99	2.99
Heating Performance (Heat Pumps)				
Heating Temp. Btuh [kW] Rating	33,600 [9.84]	33,600 [9.84]	33,600 [9.84]	33,600 [9.84]
System Power KW/COP	2.79/3.48	2.79/3.48	2.79/3.48	2.79/3.48
Low Temp. Btuh [kW] Rating	19,400 [5.68]	19,400 [5.68]	19,400 [5.68]	19,400 [5.68]
System Power KW/COP	2.56/2.22	2.56/2.22	2.56/2.22	2.56/2.22
HSPF (Btu/Watts-hr)	8	8	8	8
Compressor				
No./Type	1/Scroll	1/Scroll	1/Scroll	1/Scroll
Outdoor Sound Rating (dB)³	83	83	83	83
Outdoor Coil—Fin Type	Louvered	Louvered	Louvered	Louvered
Tube Type	Rifled	Rifled	Rifled	Rifled
Tube Size in. [mm] OD	0.375 [9.5]	0.375 [9.5]	0.375 [9.5]	0.375 [9.5]
Face Area sq. ft. [sq. m]	16.89 [1.57]	16.89 [1.57]	16.89 [1.57]	16.89 [1.57]
Rows / FPI [FPcm]	1 / 22 [9]	1 / 22 [9]	1 / 22 [9]	1 / 22 [9]
Refrigerant Control	TX Valves	TX Valves	TX Valves	TX Valves
Indoor Coil—Fin Type	Louvered	Louvered	Louvered	Louvered
Tube Type	Rifled	Rifled	Rifled	Rifled
Tube Size in. [mm]	0.375 [9.5]	0.375 [9.5]	0.375 [9.5]	0.375 [9.5]
Face Area sq. ft. [sq. m]	5.16 [0.48]	5.16 [0.48]	5.16 [0.48]	5.16 [0.48]
Rows / FPI [FPcm]	3 / 13 [5]	3 / 13 [5]	3 / 13 [5]	3 / 13 [5]
Refrigerant Control	TX Valves	TX Valves	TX Valves	TX Valves
Drain Connection No./Size in. [mm]	1/1 [25.4]	1/1 [25.4]	1/1 [25.4]	1/1 [25.4]
Outdoor Fan—Type	Propeller	Propeller	Propeller	Propeller
No. Used/Diameter in. [mm]	1/24 [609.6]	1/24 [609.6]	1/24 [609.6]	1/24 [609.6]
Drive Type/No. Speeds	Direct/1	Direct/1	Direct/1	Direct/1
CFM [L/s]	4000 [1888]	4000 [1888]	4000 [1888]	4000 [1888]
No. Motors/HP	1 at 1/3 HP	1 at 1/3 HP	1 at 1/3 HP	1 at 1/3 HP
Motor RPM	1075	1075	1075	1075
Indoor Fan—Type	FC Centrifugal	FC Centrifugal	FC Centrifugal	FC Centrifugal
No. Used/Diameter in. [mm]	1/10x10 [254x254]	1/10x10 [254x254]	1/10x10 [254x254]	1/10x10 [254x254]
Drive Type/No. Speeds	Direct/3	Belt/Variable	Belt/Variable	Direct/3
No. Motors	1	1	1	1
Motor HP	1/2	1/2	3/4	1/2
Motor RPM	1075	1725	1725	1075
Motor Frame Size	48	56	56	48
Filter—Type	Disposable	Disposable	Disposable	Disposable
Furnished	Yes	Yes	Yes	Yes
(No.) Size Recommended in. [mm]	(2)1x25x16 [25x635x406]	(2)1x25x16 [25x635x406]	(2)1x25x16 [25x635x406]	(2)1x25x16 [25x635x406]
Refrigerant Charge Oz. [g]	116 [3289]	116 [3289]	116 [3289]	116 [3289]
Weights				
Net Weight lbs. [kg]	517 [235]	517 [235]	517 [235]	517 [235]
Ship Weight lbs. [kg]	532 [241]	532 [241]	532 [241]	532 [241]

See Page 15 for Notes.

[] Designates Metric Conversions

NOMINAL SIZES 3-5 TONS [10.6-17.6 kW]

Model RJPL - Series	A036DL	A036DM	A036JK	A042CK
Cooling Performance¹				CONTINUED →
Gross Cooling Capacity Btu [kW]	38,500 [11.28]	38,500 [11.28]	37,800 [11.08]	43,500 [12.75]
EER/SEER ²	12/14	12/14	12/14	11.6/14
Nominal CFM/AHRI Rated CFM [L/s]	1200/1200 [566/566]	1200/1200 [566/566]	1200/1200 [566/566]	1400/1400 [661/661]
AHRI Net Cooling Capacity Btu [kW]	36,800 [10.78]	36,800 [10.78]	36,800 [10.78]	42,000 [12.31]
Net Sensible Capacity Btu [kW]	27,200 [7.97]	27,200 [7.97]	27,200 [7.97]	31,750 [9.3]
Net Latent Capacity Btu [kW]	9,600 [2.81]	9,600 [2.81]	9,600 [2.81]	10,250 [3]
Net System Power kW	2.99	2.99	2.99	3.64
Heating Performance (Heat Pumps)				
Heating Temp. Btuh [kW] Rating	33,600 [9.84]	33,600 [9.84]	33,600 [9.84]	40,000 [11.72]
System Power KW/COP	2.79/3.48	2.79/3.48	2.79/3.48	3.23/3.6
Low Temp. Btuh [kW] Rating	19,400 [5.68]	19,400 [5.68]	19,400 [5.68]	24,200 [7.09]
System Power KW/COP	2.56/2.22	2.56/2.22	2.56/2.22	2.94/2.4
HSPF (Btu/Watts-hr)	8	8	8	8
Compressor				
No./Type	1/Scroll	1/Scroll	1/Scroll	1/Scroll
Outdoor Sound Rating (dB)³	83	83	83	83
Outdoor Coil—Fin Type	Louvered	Louvered	Louvered	Louvered
Tube Type	Rifled	Rifled	Rifled	Rifled
Tube Size in. [mm] OD	0.375 [9.5]	0.375 [9.5]	0.375 [9.5]	0.375 [9.5]
Face Area sq. ft. [sq. m]	16.89 [1.57]	16.89 [1.57]	16.89 [1.57]	16.89 [1.57]
Rows / FPI [FPcm]	1 / 22 [9]	1 / 22 [9]	1 / 22 [9]	1 / 22 [9]
Refrigerant Control	TX Valves	TX Valves	TX Valves	TX Valves
Indoor Coil—Fin Type	Louvered	Louvered	Louvered	Louvered
Tube Type	Rifled	Rifled	Rifled	Rifled
Tube Size in. [mm]	0.375 [9.5]	0.375 [9.5]	0.375 [9.5]	0.375 [9.5]
Face Area sq. ft. [sq. m]	5.16 [0.48]	5.16 [0.48]	5.16 [0.48]	5.16 [0.48]
Rows / FPI [FPcm]	3 / 13 [5]	3 / 13 [5]	3 / 13 [5]	3 / 13 [5]
Refrigerant Control	TX Valves	TX Valves	TX Valves	TX Valves
Drain Connection No./Size in. [mm]	1/1 [25.4]	1/1 [25.4]	1/1 [25.4]	1/1 [25.4]
Outdoor Fan—Type	Propeller	Propeller	Propeller	Propeller
No. Used/Diameter in. [mm]	1/24 [609.6]	1/24 [609.6]	1/24 [609.6]	1/24 [609.6]
Drive Type/No. Speeds	Direct/1	Direct/1	Direct/1	Direct/1
CFM [L/s]	4000 [1888]	4000 [1888]	4000 [1888]	4000 [1888]
No. Motors/HP	1 at 1/3 HP	1 at 1/3 HP	1 at 1/3 HP	1 at 1/3 HP
Motor RPM	1075	1075	1075	1075
Indoor Fan—Type	FC Centrifugal	FC Centrifugal	FC Centrifugal	FC Centrifugal
No. Used/Diameter in. [mm]	1/10x10 [254x254]	1/10x10 [254x254]	1/10x10 [254x254]	1/10x10 [254x254]
Drive Type/No. Speeds	Belt/Variable	Belt/Variable	Direct/3	Direct/3
No. Motors	1	1	1	1
Motor HP	1/2	3/4	1/2	1/2
Motor RPM	1725	1725	1075	1075
Motor Frame Size	56	56	48	48
Filter—Type	Disposable	Disposable	Disposable	Disposable
Furnished	Yes	Yes	Yes	Yes
(No.) Size Recommended in. [mm]	(2)1x25x16 [25x635x406]	(2)1x25x16 [25x635x406]	(2)1x25x16 [25x635x406]	(2)1x25x16 [25x635x406]
Refrigerant Charge Oz. [g]	116 [3289]	116 [3289]	116 [3289]	120 [3402]
Weights				
Net Weight lbs. [kg]	517 [235]	517 [235]	517 [235]	521 [236]
Ship Weight lbs. [kg]	532 [241]	532 [241]	532 [241]	536 [243]

See Page 15 for Notes.

[] Designates Metric Conversions

NOMINAL SIZES 3-5 TONS [10.6-17.6 kW]

Model RJPL- Series	A042CL	A042CM	A042DK	A042DL
Cooling Performance¹				CONTINUED →
Gross Cooling Capacity Btu [kW]	44,000 [12.89]	44,000 [12.89]	43,500 [12.75]	44,000 [12.89]
EER/SEER ²	11.6/14	11.6/14	11.6/14	11.6/14
Nominal CFM/AHRI Rated CFM [L/s]	1400/1400 [661/661]	1400/1400 [661/661]	1400/1400 [661/661]	1400/1400 [661/661]
AHRI Net Cooling Capacity Btu [kW]	42,000 [12.31]	42,000 [12.31]	42,000 [12.31]	42,000 [12.31]
Net Sensible Capacity Btu [kW]	31,750 [9.3]	31,750 [9.3]	31,750 [9.3]	31,750 [9.3]
Net Latent Capacity Btu [kW]	10,250 [3]	10,250 [3]	10,250 [3]	10,250 [3]
Net System Power kW	3.64	3.64	3.64	3.64
Heating Performance (Heat Pumps)				
Heating Temp. Btuh [kW] Rating	40,000 [11.72]	40,000 [11.72]	40,000 [11.72]	40,000 [11.72]
System Power KW/COP	3.23/3.6	3.23/3.6	3.23/3.6	3.23/3.6
Low Temp. Btuh [kW] Rating	24,200 [7.09]	24,200 [7.09]	24,200 [7.09]	24,200 [7.09]
System Power KW/COP	2.94/2.4	2.94/2.4	2.94/2.4	2.94/2.4
HSPF (Btu/Watts-hr)	8	8	8	8
Compressor				
No./Type	1/Scroll	1/Scroll	1/Scroll	1/Scroll
Outdoor Sound Rating (dB)³	83	83	83	83
Outdoor Coil—Fin Type	Louvered	Louvered	Louvered	Louvered
Tube Type	Rifled	Rifled	Rifled	Rifled
Tube Size in. [mm] OD	0.375 [9.5]	0.375 [9.5]	0.375 [9.5]	0.375 [9.5]
Face Area sq. ft. [sq. m]	16.89 [1.57]	16.89 [1.57]	16.89 [1.57]	16.89 [1.57]
Rows / FPI [FPcm]	1 / 22 [9]	1 / 22 [9]	1 / 22 [9]	1 / 22 [9]
Refrigerant Control	TX Valves	TX Valves	TX Valves	TX Valves
Indoor Coil—Fin Type	Louvered	Louvered	Louvered	Louvered
Tube Type	Rifled	Rifled	Rifled	Rifled
Tube Size in. [mm]	0.375 [9.5]	0.375 [9.5]	0.375 [9.5]	0.375 [9.5]
Face Area sq. ft. [sq. m]	5.16 [0.48]	5.16 [0.48]	5.16 [0.48]	5.16 [0.48]
Rows / FPI [FPcm]	3 / 13 [5]	3 / 13 [5]	3 / 13 [5]	3 / 13 [5]
Refrigerant Control	TX Valves	TX Valves	TX Valves	TX Valves
Drain Connection No./Size in. [mm]	1/1 [25.4]	1/1 [25.4]	1/1 [25.4]	1/1 [25.4]
Outdoor Fan—Type	Propeller	Propeller	Propeller	Propeller
No. Used/Diameter in. [mm]	1/24 [609.6]	1/24 [609.6]	1/24 [609.6]	1/24 [609.6]
Drive Type/No. Speeds	Direct/1	Direct/1	Direct/1	Direct/1
CFM [L/s]	4000 [1888]	4000 [1888]	4000 [1888]	4000 [1888]
No. Motors/HP	1 at 1/3 HP	1 at 1/3 HP	1 at 1/3 HP	1 at 1/3 HP
Motor RPM	1075	1075	1075	1075
Indoor Fan—Type	FC Centrifugal	FC Centrifugal	FC Centrifugal	FC Centrifugal
No. Used/Diameter in. [mm]	1/10x10 [254x254]	1/10x10 [254x254]	1/10x10 [254x254]	1/10x10 [254x254]
Drive Type/No. Speeds	Belt/Variable	Belt/Variable	Direct/3	Belt/Variable
No. Motors	1	1	1	1
Motor HP	1/2	3/4	1/2	1/2
Motor RPM	1725	1725	1075	1725
Motor Frame Size	56	56	48	56
Filter—Type	Disposable	Disposable	Disposable	Disposable
Furnished	Yes	Yes	Yes	Yes
(No.) Size Recommended in. [mm]	(2)1x25x16 [25x635x406]	(2)1x25x16 [25x635x406]	(2)1x25x16 [25x635x406]	(2)1x25x16 [25x635x406]
Refrigerant Charge Oz. [g]	120 [3402]	120 [3402]	120 [3402]	120 [3402]
Weights				
Net Weight lbs. [kg]	521 [236]	521 [236]	521 [236]	521 [236]
Ship Weight lbs. [kg]	536 [243]	536 [243]	536 [243]	536 [243]

See Page 15 for Notes.

[] Designates Metric Conversions

NOMINAL SIZES 3-5 TONS [10.6-17.6 kW]

Model RJPL - Series	A042DM	A042JK	A048CK	A048CL
Cooling Performance¹				CONTINUED →
Gross Cooling Capacity Btu [kW]	44,000 [12.89]	43,500 [12.75]	49,000 [14.36]	50,000 [14.65]
EER/SEER ²	11.6/14	11.6/14	11.6/14	11.6/14
Nominal CFM/AHRI Rated CFM [L/s]	1400/1400 [661/661]	1400/1400 [661/661]	1600/1600 [755/755]	1600/1600 [755/755]
AHRI Net Cooling Capacity Btu [kW]	42,000 [12.31]	42,000 [12.31]	47,500 [13.92]	47,500 [13.92]
Net Sensible Capacity Btu [kW]	31,750 [9.3]	31,750 [9.3]	36,200 [10.61]	36,200 [10.61]
Net Latent Capacity Btu [kW]	10,250 [3]	10,250 [3]	11,300 [3.31]	11,300 [3.31]
Net System Power kW	3.64	3.64	4.09	4.09
Heating Performance (Heat Pumps)				
Heating Temp. Btuh [kW] Rating	40,000 [11.72]	40,000 [11.72]	49,000 [14.36]	49,000 [14.36]
System Power KW/COP	3.23/3.6	3.23/3.6	3.76/3.8	3.76/3.8
Low Temp. Btuh [kW] Rating	24,200 [7.09]	24,200 [7.09]	29,800 [8.73]	29,800 [8.73]
System Power KW/COP	2.94/2.4	2.94/2.4	3.48/2.4	3.48/2.4
HSPF (Btu/Watts-hr)	8	8	8	8
Compressor				
No./Type	1/Scroll	1/Scroll	1/Scroll	1/Scroll
Outdoor Sound Rating (dB)³	83	83	83	83
Outdoor Coil—Fin Type	Louvered	Louvered	Louvered	Louvered
Tube Type	Rifled	Rifled	Rifled	Rifled
Tube Size in. [mm] OD	0.375 [9.5]	0.375 [9.5]	0.375 [9.5]	0.375 [9.5]
Face Area sq. ft. [sq. m]	16.89 [1.57]	16.89 [1.57]	16.56 [1.54]	16.56 [1.54]
Rows / FPI [FPcm]	1 / 22 [9]	1 / 22 [9]	2 / 22 [9]	2 / 22 [9]
Refrigerant Control	TX Valves	TX Valves	TX Valves	TX Valves
Indoor Coil—Fin Type	Louvered	Louvered	Louvered	Louvered
Tube Type	Rifled	Rifled	Rifled	Rifled
Tube Size in. [mm]	0.375 [9.5]	0.375 [9.5]	0.375 [9.5]	0.375 [9.5]
Face Area sq. ft. [sq. m]	5.16 [0.48]	5.16 [0.48]	5.16 [0.48]	5.16 [0.48]
Rows / FPI [FPcm]	3 / 13 [5]	3 / 13 [5]	4 / 13 [5]	4 / 13 [5]
Refrigerant Control	TX Valves	TX Valves	TX Valves	TX Valves
Drain Connection No./Size in. [mm]	1/1 [25.4]	1/1 [25.4]	1/1 [25.4]	1/1 [25.4]
Outdoor Fan—Type	Propeller	Propeller	Propeller	Propeller
No. Used/Diameter in. [mm]	1/24 [609.6]	1/24 [609.6]	1/24 [609.6]	1/24 [609.6]
Drive Type/No. Speeds	Direct/1	Direct/1	Direct/1	Direct/1
CFM [L/s]	4000 [1888]	4000 [1888]	4000 [1888]	4000 [1888]
No. Motors/HP	1 at 1/3 HP	1 at 1/3 HP	1 at 1/3 HP	1 at 1/3 HP
Motor RPM	1075	1075	1075	1075
Indoor Fan—Type	FC Centrifugal	FC Centrifugal	FC Centrifugal	FC Centrifugal
No. Used/Diameter in. [mm]	1/10x10 [254x254]	1/10x10 [254x254]	1/10x10 [254x254]	1/10x10 [254x254]
Drive Type/No. Speeds	Belt/Variable	Direct/3	Direct/3	Belt/Variable
No. Motors	1	1	1	1
Motor HP	3/4	1/2	1/2	1/2
Motor RPM	1725	1075	1075	1725
Motor Frame Size	56	48	48	56
Filter—Type	Disposable	Disposable	Disposable	Disposable
Furnished	Yes	Yes	Yes	Yes
(No.) Size Recommended in. [mm]	(2)1x25x16 [25x635x406]	(2)1x25x16 [25x635x406]	(2)1x25x16 [25x635x406]	(2)1x25x16 [25x635x406]
Refrigerant Charge Oz. [g]	120 [3402]	120 [3402]	187 [5301]	187 [5301]
Weights				
Net Weight lbs. [kg]	521 [236]	521 [236]	535 [243]	535 [243]
Ship Weight lbs. [kg]	536 [243]	536 [243]	550 [249]	550 [249]

See Page 15 for Notes.

[] Designates Metric Conversions

NOMINAL SIZES 3-5 TONS [10.6-17.6 kW]

Model RJPL- Series	A048CM	A048DK	A048DL	A048DM
Cooling Performance¹				CONTINUED →
Gross Cooling Capacity Btu [kW]	50,000 [14.65]	49,000 [14.36]	50,000 [14.65]	50,000 [14.65]
EER/SEER ²	11.6/14	11.6/14	11.6/14	11.6/14
Nominal CFM/AHRI Rated CFM [L/s]	1600/1600 [755/755]	1600/1600 [755/755]	1600/1600 [755/755]	1600/1600 [755/755]
AHRI Net Cooling Capacity Btu [kW]	47,500 [13.92]	47,500 [13.92]	47,500 [13.92]	47,500 [13.92]
Net Sensible Capacity Btu [kW]	36,200 [10.61]	36,200 [10.61]	36,200 [10.61]	36,200 [10.61]
Net Latent Capacity Btu [kW]	11,300 [3.31]	11,300 [3.31]	11,300 [3.31]	11,300 [3.31]
Net System Power kW	4.09	4.09	4.09	4.09
Heating Performance (Heat Pumps)				
Heating Temp. Btuh [kW] Rating	49,000 [14.36]	49,000 [14.36]	49,000 [14.36]	49,000 [14.36]
System Power KW/COP	3.76/3.8	3.76/3.8	3.76/3.8	3.76/3.8
Low Temp. Btuh [kW] Rating	29,800 [8.73]	29,800 [8.73]	29,800 [8.73]	29,800 [8.73]
System Power KW/COP	3.48/2.4	3.48/2.4	3.48/2.4	3.48/2.4
HSPF (Btu/Watts-hr)	8	8	8	8
Compressor				
No./Type	1/Scroll	1/Scroll	1/Scroll	1/Scroll
Outdoor Sound Rating (dB)³	83	83	83	83
Outdoor Coil—Fin Type	Louvered	Louvered	Louvered	Louvered
Tube Type	Rifled	Rifled	Rifled	Rifled
Tube Size in. [mm] OD	0.375 [9.5]	0.375 [9.5]	0.375 [9.5]	0.375 [9.5]
Face Area sq. ft. [sq. m]	16.56 [1.54]	16.56 [1.54]	16.56 [1.54]	16.56 [1.54]
Rows / FPI [FPcm]	2 / 22 [9]	2 / 22 [9]	2 / 22 [9]	2 / 22 [9]
Refrigerant Control	TX Valves	TX Valves	TX Valves	TX Valves
Indoor Coil—Fin Type	Louvered	Louvered	Louvered	Louvered
Tube Type	Rifled	Rifled	Rifled	Rifled
Tube Size in. [mm]	0.375 [9.5]	0.375 [9.5]	0.375 [9.5]	0.375 [9.5]
Face Area sq. ft. [sq. m]	5.16 [0.48]	5.16 [0.48]	5.16 [0.48]	5.16 [0.48]
Rows / FPI [FPcm]	4 / 13 [5]	4 / 13 [5]	4 / 13 [5]	4 / 13 [5]
Refrigerant Control	TX Valves	TX Valves	TX Valves	TX Valves
Drain Connection No./Size in. [mm]	1/1 [25.4]	1/1 [25.4]	1/1 [25.4]	1/1 [25.4]
Outdoor Fan—Type	Propeller	Propeller	Propeller	Propeller
No. Used/Diameter in. [mm]	1/24 [609.6]	1/24 [609.6]	1/24 [609.6]	1/24 [609.6]
Drive Type/No. Speeds	Direct/1	Direct/1	Direct/1	Direct/1
CFM [L/s]	4000 [1888]	4000 [1888]	4000 [1888]	4000 [1888]
No. Motors/HP	1 at 1/3 HP	1 at 1/3 HP	1 at 1/3 HP	1 at 1/3 HP
Motor RPM	1075	1075	1075	1075
Indoor Fan—Type	FC Centrifugal	FC Centrifugal	FC Centrifugal	FC Centrifugal
No. Used/Diameter in. [mm]	1/10x10 [254x254]	1/10x10 [254x254]	1/10x10 [254x254]	1/10x10 [254x254]
Drive Type/No. Speeds	Belt/Variable	Direct/3	Belt/Variable	Belt/Variable
No. Motors	1	1	1	1
Motor HP	3/4	1/2	1/2	3/4
Motor RPM	1725	1075	1725	1725
Motor Frame Size	56	48	56	56
Filter—Type	Disposable	Disposable	Disposable	Disposable
Furnished	Yes	Yes	Yes	Yes
(No.) Size Recommended in. [mm]	(2)1x25x16 [25x635x406]	(2)1x25x16 [25x635x406]	(2)1x25x16 [25x635x406]	(2)1x25x16 [25x635x406]
Refrigerant Charge Oz. [g]	187 [5301]	187 [5301]	187 [5301]	187 [5301]
Weights				
Net Weight lbs. [kg]	535 [243]	535 [243]	535 [243]	535 [243]
Ship Weight lbs. [kg]	550 [249]	550 [249]	550 [249]	550 [249]

See Page 15 for Notes.

[] Designates Metric Conversions

NOMINAL SIZES 3-5 TONS [10.6-17.6 kW]

Model RJPL - Series	A048JK	A060CK	A060CL	A060CM
Cooling Performance¹				CONTINUED →
Gross Cooling Capacity Btu [kW]	49,000 [14.36]	61,000 [17.87]	61,000 [17.87]	61,000 [17.87]
EER/SEER ²	11.6/14	11.7/14	11.7/14	11.7/14
Nominal CFM/AHRI Rated CFM [L/s]	1600/1600 [755/755]	2000/1850 [944/873]	2000/1850 [944/873]	2000/1850 [944/873]
AHRI Net Cooling Capacity Btu [kW]	47,500 [13.92]	59,500 [17.43]	59,500 [17.43]	59,500 [17.43]
Net Sensible Capacity Btu [kW]	36,200 [10.61]	43,600 [12.77]	43,600 [12.77]	43,600 [12.77]
Net Latent Capacity Btu [kW]	11,300 [3.31]	15,900 [4.66]	15,900 [4.66]	15,900 [4.66]
Net System Power kW	4.09	5.05	5.05	5.05
Heating Performance (Heat Pumps)				
Heating Temp. Btuh [kW] Rating	49,000 [14.36]	59,500 [17.43]	59,500 [17.43]	59,500 [17.43]
System Power KW/COP	3.76/3.8	4.8/3.6	4.8/3.6	4.8/3.6
Low Temp. Btuh [kW] Rating	29,800 [8.73]	36,400 [10.67]	36,400 [10.67]	36,400 [10.67]
System Power KW/COP	3.48/2.4	4.47/2.2	4.47/2.2	4.47/2.2
HSPF (Btu/Watts-hr)	8	8	8	8
Compressor				
No./Type	1/Scroll	1/Scroll	1/Scroll	1/Scroll
Outdoor Sound Rating (dB)³	83	83	83	83
Outdoor Coil—Fin Type	Louvered	Louvered	Louvered	Louvered
Tube Type	Rifled	Rifled	Rifled	Rifled
Tube Size in. [mm] OD	0.375 [9.5]	0.375 [9.5]	0.375 [9.5]	0.375 [9.5]
Face Area sq. ft. [sq. m]	16.56 [1.54]	16.56 [1.54]	16.56 [1.54]	16.56 [1.54]
Rows / FPI [FPcm]	2 / 22 [9]	2 / 22 [9]	2 / 22 [9]	2 / 22 [9]
Refrigerant Control	TX Valves	TX Valves	TX Valves	TX Valves
Indoor Coil—Fin Type	Louvered	Louvered	Louvered	Louvered
Tube Type	Rifled	Rifled	Rifled	Rifled
Tube Size in. [mm]	0.375 [9.5]	0.375 [9.5]	0.375 [9.5]	0.375 [9.5]
Face Area sq. ft. [sq. m]	5.16 [0.48]	5.16 [0.48]	5.16 [0.48]	5.16 [0.48]
Rows / FPI [FPcm]	4 / 13 [5]	4 / 13 [5]	4 / 13 [5]	4 / 13 [5]
Refrigerant Control	TX Valves	TX Valves	TX Valves	TX Valves
Drain Connection No./Size in. [mm]	1/1 [25.4]	1/1 [25.4]	1/1 [25.4]	1/1 [25.4]
Outdoor Fan—Type	Propeller	Propeller	Propeller	Propeller
No. Used/Diameter in. [mm]	1/24 [609.6]	1/24 [609.6]	1/24 [609.6]	1/24 [609.6]
Drive Type/No. Speeds	Direct/1	Direct/1	Direct/1	Direct/1
CFM [L/s]	4000 [1888]	4000 [1888]	4000 [1888]	4000 [1888]
No. Motors/HP	1 at 1/3 HP	1 at 1/3 HP	1 at 1/3 HP	1 at 1/3 HP
Motor RPM	1075	1075	1075	1075
Indoor Fan—Type	FC Centrifugal	FC Centrifugal	FC Centrifugal	FC Centrifugal
No. Used/Diameter in. [mm]	1/10x10 [254x254]	1/11x9 [279x229]	1/10x10 [254x254]	1/10x10 [254x254]
Drive Type/No. Speeds	Direct/3	Direct/2	Belt/Variable	Belt/Variable
No. Motors	1	1	1	1
Motor HP	1/2	1	3/4	1
Motor RPM	1075	1100	1725	1725
Motor Frame Size	48	48	56	56
Filter—Type	Disposable	Disposable	Disposable	Disposable
Furnished	Yes	Yes	Yes	Yes
(No.) Size Recommended in. [mm]	(2)1x25x16 [25x635x406]	(2)1x25x16 [25x635x406]	(2)1x25x16 [25x635x406]	(2)1x25x16 [25x635x406]
Refrigerant Charge Oz. [g]	187 [5301]	195 [5528]	195 [5528]	197 [5585]
Weights				
Net Weight lbs. [kg]	535 [243]	565 [256]	565 [256]	565 [256]
Ship Weight lbs. [kg]	550 [249]	580 [263]	580 [263]	580 [263]

See Page 15 for Notes.

[] Designates Metric Conversions



NOMINAL SIZES 3-5 TONS [10.6-17.6 kW]

Model RJPL- Series	A060DK	A060DL	A060DM	A060JK
Cooling Performance¹				
Gross Cooling Capacity Btu [kW]	61,000 [17.87]	61,000 [17.87]	61,000 [17.87]	61,000 [17.87]
EER/SEER ²	11.7/14	11.7/14	11.7/14	11.7/14
Nominal CFM/AHRI Rated CFM [L/s]	2000/1850 [944/873]	2000/1850 [944/873]	2000/1850 [944/873]	2000/1850 [944/873]
AHRI Net Cooling Capacity Btu [kW]	59,500 [17.43]	59,500 [17.43]	59,500 [17.43]	59,500 [17.43]
Net Sensible Capacity Btu [kW]	43,600 [12.77]	43,600 [12.77]	43,600 [12.77]	43,600 [12.77]
Net Latent Capacity Btu [kW]	15,900 [4.66]	15,900 [4.66]	15,900 [4.66]	15,900 [4.66]
Net System Power kW	5.05	5.05	5.05	5.05
Heating Performance (Heat Pumps)				
Heating Temp. Btuh [kW] Rating	59,500 [17.43]	59,500 [17.43]	59,500 [17.43]	59,500 [17.43]
System Power KW/COP	4.8/3.6	4.8/3.6	4.8/3.6	4.8/3.6
Low Temp. Btuh [kW] Rating	36,400 [10.67]	36,400 [10.67]	36,400 [10.67]	36,400 [10.67]
System Power KW/COP	4.47/2.2	4.47/2.2	4.47/2.2	4.47/2.2
HSPF (Btu/Watts-hr)	8	8	8	8
Compressor				
No./Type	1/Scroll	1/Scroll	1/Scroll	1/Scroll
Outdoor Sound Rating (dB)³				
	83	83	83	83
Outdoor Coil—Fin Type				
Tube Type	Louvered	Louvered	Louvered	Louvered
	Rifled	Rifled	Rifled	Rifled
Tube Size in. [mm] OD	0.375 [9.5]	0.375 [9.5]	0.375 [9.5]	0.375 [9.5]
Face Area sq. ft. [sq. m]	16.56 [1.54]	16.56 [1.54]	16.56 [1.54]	16.56 [1.54]
Rows / FPI [FPcm]	2 / 22 [9]	2 / 22 [9]	2 / 22 [9]	2 / 22 [9]
Refrigerant Control	TX Valves	TX Valves	TX Valves	TX Valves
Indoor Coil—Fin Type				
Tube Type	Louvered	Louvered	Louvered	Louvered
	Rifled	Rifled	Rifled	Rifled
Tube Size in. [mm]	0.375 [9.5]	0.375 [9.5]	0.375 [9.5]	0.375 [9.5]
Face Area sq. ft. [sq. m]	5.16 [0.48]	5.16 [0.48]	5.16 [0.48]	5.16 [0.48]
Rows / FPI [FPcm]	4 / 13 [5]	4 / 13 [5]	4 / 13 [5]	4 / 13 [5]
Refrigerant Control	TX Valves	TX Valves	TX Valves	TX Valves
Drain Connection No./Size in. [mm]	1/1 [25.4]	1/1 [25.4]	1/1 [25.4]	1/1 [25.4]
Outdoor Fan—Type				
	Propeller	Propeller	Propeller	Propeller
No. Used/Diameter in. [mm]	1/24 [609.6]	1/24 [609.6]	1/24 [609.6]	1/24 [609.6]
Drive Type/No. Speeds	Direct/1	Direct/1	Direct/1	Direct/1
CFM [L/s]	4000 [1888]	4000 [1888]	4000 [1888]	4000 [1888]
No. Motors/HP	1 at 1/3 HP	1 at 1/3 HP	1 at 1/3 HP	1 at 1/3 HP
Motor RPM	1075	1075	1075	1075
Indoor Fan—Type				
	FC Centrifugal	FC Centrifugal	FC Centrifugal	FC Centrifugal
No. Used/Diameter in. [mm]	1/11x9 [279x229]	1/10x10 [254x254]	1/10x10 [254x254]	1/11x9 [279x229]
Drive Type/No. Speeds	Direct/2	Belt/Variable	Belt/Variable	Direct/2
No. Motors	1	1	1	1
Motor HP	1	3/4	1	1
Motor RPM	1100	1725	1725	1100
Motor Frame Size	48	56	56	48
Filter—Type				
	Disposable	Disposable	Disposable	Disposable
Furnished	Yes	Yes	Yes	Yes
(No.) Size Recommended in. [mm]	(2)1x25x16 [25x635x406]	(2)1x25x16 [25x635x406]	(2)1x25x16 [25x635x406]	(2)1x25x16 [25x635x406]
Refrigerant Charge Oz. [g]				
	197 [5585]	195 [5528]	197 [5585]	197 [5585]
Weights				
Net Weight lbs. [kg]	565 [256]	565 [256]	565 [256]	565 [256]
Ship Weight lbs. [kg]	580 [263]	580 [263]	580 [263]	580 [263]

See Page 15 for Notes.

[] Designates Metric Conversions

NOTES:

1. Cooling Performance is rated at 95° F ambient, 80° F entering dry bulb, 67° F entering wet bulb. Gross capacity does not include the effect of fan motor heat. AHRI capacity is net and includes the effect of fan motor heat. Units are suitable for operation to $\pm 20\%$ of nominal cfm. Units are certified in accordance with the Unitary Air Conditioner Equipment certification program, which is based on AHRI Standard 210/240 or 360.
2. EER and/or SEER are rated at AHRI conditions and in accordance with DOE test procedures.
3. Outdoor Sound Rating shown is tested in accordance with AHRI Standard 270.



COOLING PERFORMANCE DATA—RJPL-A036

ENTERING INDOOR AIR @ 80°F [26.7°C] dbE ①											
wbE			71°F [21.7°C]			67°F [19.4°C]			63°F [17.2°C]		
CFM [L/s]			1440 [680]	1200 [566]	960 [453]	1440 [680]	1200 [566]	960 [453]	1440 [680]	1200 [566]	960 [453]
DR ①			.17	.14	.10	.17	.14	.10	.17	.14	.10
OUTDOOR DRY BULB TEMPERATURE °F [°C]	75 [23.9]	Total BTUH [kW]	45.5 [13.33]	43.9 [12.87]	42.3 [12.40]	43.7 [12.81]	42.2 [12.37]	40.6 [11.90]	40.9 [11.99]	39.4 [11.55]	38.0 [11.14]
		Sens BTUH [kW]	27.3 [8.00]	24.9 [7.30]	22.6 [6.62]	33.1 [9.70]	30.3 [8.88]	27.5 [8.06]	38.0 [11.14]	34.8 [10.20]	31.5 [9.23]
		Power	2.2	2.2	2.1	2.2	2.2	2.1	2.2	2.2	2.1
	80 [26.7]	Total BTUH [kW]	45.0 [13.19]	43.4 [12.72]	41.8 [12.25]	43.2 [12.66]	41.7 [12.22]	40.2 [11.78]	40.3 [11.81]	38.9 [11.40]	37.5 [10.99]
		Sens BTUH [kW]	27.0 [7.91]	24.7 [7.24]	22.4 [6.56]	32.9 [9.64]	30.1 [8.82]	27.3 [8.00]	37.7 [11.05]	34.6 [10.14]	31.3 [9.17]
		Power	2.3	2.3	2.3	2.3	2.3	2.3	2.3	2.3	2.2
	85 [29.4]	Total BTUH [kW]	44.0 [12.90]	42.4 [12.43]	40.9 [11.99]	42.2 [12.37]	40.7 [11.93]	39.2 [11.49]	39.3 [11.52]	38.0 [11.14]	36.6 [10.73]
		Sens BTUH [kW]	26.5 [7.77]	24.3 [7.12]	22.0 [6.45]	32.4 [9.50]	29.6 [8.67]	26.9 [7.88]	37.4 [10.96]	34.1 [9.99]	30.9 [9.06]
		Power	2.5	2.4	2.4	2.5	2.4	2.4	2.4	2.4	2.4
	90 [32.2]	Total BTUH [kW]	42.6 [12.48]	41.1 [12.05]	39.6 [11.61]	40.8 [11.96]	39.4 [11.55]	38.0 [11.14]	38.0 [11.14]	36.6 [10.73]	35.3 [10.35]
Sens BTUH [kW]		25.8 [7.56]	23.6 [6.92]	21.4 [6.27]	31.7 [9.29]	29.0 [8.50]	26.3 [7.71]	36.7 [10.76]	33.5 [9.82]	30.3 [8.88]	
Power		2.6	2.6	2.5	2.6	2.6	2.5	2.6	2.5	2.5	
95 [35]	Total BTUH [kW]	41.0 [12.02]	39.5 [11.58]	38.1 [11.17]	39.2 [11.49]	37.8 [11.08]	36.4 [10.67]	36.3 [10.64]	35.1 [10.29]	33.8 [9.91]	
	Sens BTUH [kW]	25.0 [7.33]	22.9 [6.71]	20.7 [6.07]	30.9 [9.06]	28.2 [8.26]	25.6 [7.50]	35.7 [10.46]	32.7 [9.58]	29.7 [8.70]	
	Power	2.7	2.7	2.6	2.7	2.7	2.6	2.7	2.7	2.6	
100 [37.8]	Total BTUH [kW]	39.2 [11.49]	37.8 [11.08]	36.5 [10.70]	37.4 [10.96]	36.1 [10.58]	34.8 [10.20]	34.6 [10.14]	33.4 [9.79]	32.2 [9.44]	
	Sens BTUH [kW]	24.1 [7.06]	22.1 [6.48]	20.0 [5.86]	30.0 [8.79]	27.4 [8.03]	24.9 [7.30]	34.6 [10.14]	31.9 [9.35]	28.9 [8.47]	
	Power	2.9	2.8	2.8	2.9	2.8	2.8	2.8	2.8	2.8	
105 [40.6]	Total BTUH [kW]	37.5 [10.99]	36.1 [10.58]	34.8 [10.20]	35.7 [10.46]	34.4 [10.08]	33.2 [9.73]	32.8 [9.61]	31.7 [9.29]	30.5 [8.94]	
	Sens BTUH [kW]	23.3 [6.83]	21.3 [6.24]	19.3 [5.66]	29.1 [8.53]	26.7 [7.83]	24.2 [7.09]	32.8 [9.61]	31.1 [9.11]	28.2 [8.26]	
	Power	3.0	3.0	2.9	3.0	3.0	2.9	3.0	2.9	2.9	
110 [43.3]	Total BTUH [kW]	35.8 [10.49]	34.5 [10.11]	33.3 [9.76]	34.0 [9.96]	32.8 [9.61]	31.6 [9.26]	31.2 [9.14]	30.1 [8.82]	29.0 [8.50]	
	Sens BTUH [kW]	22.5 [6.59]	20.6 [6.04]	18.7 [5.48]	28.4 [8.32]	26.0 [7.62]	23.5 [6.89]	31.2 [9.14]	30.1 [8.82]	27.6 [8.09]	
	Power	3.1	3.1	3.0	3.1	3.1	3.0	3.1	3.1	3.0	
115 [46.1]	Total BTUH [kW]	34.4 [10.08]	33.2 [9.73]	32.0 [9.38]	32.6 [9.55]	31.5 [9.23]	30.3 [8.88]	29.7 [8.70]	28.7 [8.41]	27.7 [8.12]	
	Sens BTUH [kW]	22.0 [6.45]	20.1 [5.89]	18.2 [5.33]	27.8 [8.15]	25.5 [7.47]	23.1 [6.77]	29.7 [8.70]	28.7 [8.41]	27.1 [7.94]	
	Power	3.3	3.2	3.2	3.3	3.2	3.2	3.3	3.2	3.1	

DR —Depression ratio
dbE —Entering air dry bulb
wbE —Entering air wet bulb

Total —Total capacity x 1000 BTUH
Sens —Sensible capacity x 1000 BTUH
Power —KW input

NOTES:

① When the entering air dry bulb is other than 80°F [27°C], adjust the sensible capacity from the table by adding $[1.10 \times \text{CFM} \times (1 - \text{DR}) \times (\text{dbE} - 80)]$.

HEATING PERFORMANCE DATA—RJPL-A036

IDB											
CFM [L/s]			60°F [15.5°C]			70°F [21.1°C]			80°F [26.7°C]		
			1440 [680]	1200 [566]	960 [453]	1440 [680]	1200 [566]	960 [453]	1440 [680]	1200 [566]	960 [453]
OUTDOOR DRY BULB TEMPERATURE °F [°C]	0 [-17.8]	Total BTUH [kW]	10.9 [3.19]	10.7 [3.14]	10.6 [3.11]	9.7 [2.84]	9.6 [2.81]	9.5 [2.78]	8.3 [2.43]	8.2 [2.40]	8.1 [2.37]
		Power	1.8	1.9	1.9	2.1	2.1	2.2	2.4	2.4	2.5
	5 [26.7]	Total BTUH [kW]	13.4 [3.93]	13.2 [3.87]	13.0 [3.81]	12.2 [3.58]	12.0 [3.52]	11.9 [3.49]	10.8 [3.17]	10.6 [3.11]	10.5 [3.08]
		Power	1.9	1.9	2.0	2.1	2.2	2.2	2.4	2.5	2.5
	10 [-12.2]	Total BTUH [kW]	15.8 [4.63]	15.6 [4.57]	15.4 [4.51]	14.7 [4.31]	14.5 [4.25]	14.3 [4.19]	13.3 [3.90]	13.1 [3.84]	12.9 [3.78]
		Power	1.9	2.0	2.0	2.2	2.2	2.3	2.4	2.5	2.6
	15 [32.2]	Total BTUH [kW]	18.3 [5.36]	18.0 [5.28]	17.8 [5.22]	17.1 [5.01]	16.9 [4.95]	16.7 [4.89]	15.7 [4.60]	15.5 [4.54]	15.3 [4.48]
		Power	2.0	2.0	2.1	2.2	2.2	2.3	2.5	2.5	2.6
	20 [-6.6]	Total BTUH [kW]	20.8 [6.10]	20.5 [6.01]	20.2 [5.92]	19.6 [5.74]	19.3 [5.66]	19.1 [5.60]	18.2 [5.33]	18.0 [5.28]	17.7 [5.19]
		Power	2.0	2.0	2.1	2.2	2.3	2.3	2.5	2.6	2.7
25 [37.8]	Total BTUH [kW]	23.3 [6.83]	22.9 [6.71]	22.6 [6.62]	22.1 [6.48]	21.8 [6.39]	21.5 [6.30]	20.7 [6.07]	20.4 [5.98]	20.1 [5.89]	
	Power	2.0	2.1	2.1	2.3	2.3	2.4	2.6	2.6	2.7	
30 [-1.1]	Total BTUH [kW]	25.7 [7.53]	25.4 [7.44]	25.0 [7.33]	24.6 [7.21]	24.2 [7.09]	23.9 [7.00]	23.2 [6.80]	22.8 [6.68]	22.5 [6.59]	
	Power	2.1	2.1	2.2	2.3	2.4	2.4	2.6	2.7	2.7	
35 [43.3]	Total BTUH [kW]	28.2 [8.26]	27.8 [8.15]	27.4 [8.03]	27.1 [7.94]	26.7 [7.83]	26.3 [7.71]	25.7 [7.53]	25.3 [7.41]	24.9 [7.30]	
	Power	2.1	2.2	2.2	2.3	2.4	2.5	2.6	2.7	2.8	
40 [4.4]	Total BTUH [kW]	30.7 [9.00]	30.3 [8.88]	29.8 [8.73]	29.6 [8.67]	29.1 [8.53]	28.7 [8.41]	28.1 [8.24]	27.7 [8.12]	27.4 [8.03]	
	Power	2.1	2.2	2.2	2.4	2.4	2.5	2.7	2.7	2.8	
45 [46.1]	Total BTUH [kW]	33.2 [9.73]	32.7 [9.58]	32.3 [9.47]	32.0 [9.38]	31.6 [9.26]	31.1 [9.11]	30.6 [8.97]	30.2 [8.85]	29.8 [8.73]	
	Power	2.2	2.2	2.3	2.4	2.5	2.5	2.7	2.8	2.8	
50 [10]	Total BTUH [kW]	35.7 [10.46]	35.2 [10.32]	34.7 [10.17]	34.5 [10.11]	34.1 [9.99]	33.6 [9.85]	33.1 [9.70]	32.7 [9.58]	32.2 [9.44]	
	Power	2.2	2.3	2.3	2.4	2.5	2.6	2.7	2.8	2.9	

IDB—Indoor air dry bulb

[] Designates Metric Conversions





COOLING PERFORMANCE DATA—RJPL-A042

ENTERING INDOOR AIR @ 80°F [26.7°C] dbE ①											
wbE			71°F [21.7°C]			67°F [19.4°C]			63°F [17.2°C]		
CFM [L/s]			1680 [793]	1400 [661]	1120 [529]	1680 [793]	1400 [661]	1120 [529]	1680 [793]	1400 [661]	1120 [529]
DR ①			.15	.12	.07	.15	.12	.07	.15	.12	.07
OUTDOOR DRY BULB TEMPERATURE °F [°C]	75 [23.9]	Total BTUH [kW]	54.1 [15.86]	52.2 [15.30]	50.3 [14.74]	51.0 [14.95]	49.2 [14.42]	47.4 [13.89]	47.7 [13.98]	46.0 [13.48]	44.3 [12.98]
		Sens BTUH [kW]	31.9 [9.35]	29.2 [8.56]	26.4 [7.74]	38.7 [11.34]	35.4 [10.37]	32.1 [9.41]	44.1 [12.92]	40.5 [11.87]	36.7 [10.76]
		Power	2.6	2.6	2.6	2.6	2.6	2.5	2.6	2.6	2.5
	80 [26.7]	Total BTUH [kW]	52.8 [15.47]	50.9 [14.92]	49.1 [14.39]	49.7 [14.57]	47.9 [14.04]	46.2 [13.54]	46.4 [13.60]	44.8 [13.13]	43.2 [12.66]
		Sens BTUH [kW]	31.6 [9.26]	28.9 [8.47]	26.2 [7.68]	38.5 [11.28]	35.2 [10.32]	31.9 [9.35]	44.1 [12.92]	40.2 [11.78]	36.5 [10.70]
		Power	2.8	2.8	2.7	2.8	2.7	2.7	2.8	2.7	2.7
	85 [29.4]	Total BTUH [kW]	51.3 [15.03]	49.5 [14.51]	47.7 [13.98]	48.2 [14.13]	46.5 [13.63]	44.9 [13.16]	45.0 [13.19]	43.4 [12.72]	41.8 [12.25]
		Sens BTUH [kW]	31.1 [9.11]	28.4 [8.32]	25.8 [7.56]	37.9 [11.11]	34.7 [10.17]	31.5 [9.23]	43.6 [12.78]	39.7 [11.63]	36.0 [10.55]
		Power	3.0	2.9	2.9	3.0	2.9	2.9	3.0	2.9	2.9
	90 [32.2]	Total BTUH [kW]	49.8 [14.59]	48.0 [14.07]	46.3 [13.57]	46.7 [13.69]	45.0 [13.19]	43.4 [12.72]	43.4 [12.72]	41.9 [12.28]	40.3 [11.81]
Sens BTUH [kW]		30.3 [8.88]	27.7 [8.12]	25.1 [7.36]	37.2 [10.90]	34.0 [9.96]	30.8 [9.03]	42.7 [12.51]	39.0 [11.43]	35.4 [10.37]	
Power		3.1	3.1	3.0	3.1	3.1	3.0	3.1	3.1	3.0	
95 [35]	Total BTUH [kW]	48.1 [14.10]	46.4 [13.60]	44.7 [13.10]	45.0 [13.19]	43.4 [12.72]	41.8 [12.25]	41.7 [12.22]	40.2 [11.78]	38.8 [11.37]	
	Sens BTUH [kW]	29.4 [8.62]	26.9 [7.88]	24.4 [7.15]	36.2 [10.61]	33.1 [9.70]	30.1 [8.82]	41.7 [12.22]	38.2 [11.20]	34.6 [10.14]	
	Power	3.3	3.3	3.2	3.3	3.2	3.2	3.3	3.2	3.2	
100 [37.8]	Total BTUH [kW]	46.3 [13.57]	44.7 [13.10]	43.1 [12.63]	43.2 [12.66]	41.7 [12.22]	40.2 [11.78]	40.0 [11.72]	38.6 [11.31]	37.2 [10.90]	
	Sens BTUH [kW]	28.4 [8.32]	26.0 [7.62]	23.6 [6.92]	35.2 [10.32]	32.2 [9.44]	29.2 [8.56]	40.0 [11.72]	37.3 [10.93]	33.8 [9.91]	
	Power	3.5	3.4	3.4	3.5	3.4	3.3	3.5	3.4	3.3	
105 [40.6]	Total BTUH [kW]	44.6 [13.07]	43.0 [12.60]	41.4 [12.13]	41.5 [12.16]	40.0 [11.72]	38.6 [11.31]	38.2 [11.20]	36.9 [10.81]	35.5 [10.40]	
	Sens BTUH [kW]	27.4 [8.03]	25.1 [7.36]	22.7 [6.65]	34.2 [10.02]	31.3 [9.17]	28.4 [8.32]	38.2 [11.20]	36.3 [10.64]	33.0 [9.67]	
	Power	3.6	3.6	3.5	3.6	3.6	3.5	3.6	3.6	3.5	
110 [43.3]	Total BTUH [kW]	42.8 [12.54]	41.3 [12.10]	39.8 [11.66]	39.7 [11.63]	38.3 [11.22]	36.9 [10.81]	36.4 [10.67]	35.2 [10.32]	33.9 [9.94]	
	Sens BTUH [kW]	26.4 [7.74]	24.2 [7.09]	21.9 [6.42]	33.3 [9.76]	30.4 [8.91]	27.6 [8.09]	36.4 [10.67]	35.2 [10.32]	32.2 [9.44]	
	Power	3.8	3.7	3.7	3.8	3.7	3.7	3.8	3.7	3.7	
115 [46.1]	Total BTUH [kW]	41.1 [12.05]	39.7 [11.63]	38.2 [11.20]	38.0 [11.14]	36.7 [10.76]	35.4 [10.37]	34.7 [10.17]	33.5 [9.82]	32.3 [9.47]	
	Sens BTUH [kW]	25.6 [7.50]	23.4 [6.86]	21.3 [6.24]	32.5 [9.52]	29.7 [8.70]	26.9 [7.88]	34.7 [10.17]	33.5 [9.82]	31.5 [9.23]	
	Power	4.0	3.9	3.8	4.0	3.9	3.8	4.0	3.9	3.8	

DR —Depression ratio
dbE —Entering air dry bulb
wbE—Entering air wet bulb

Total —Total capacity x 1000 BTUH
Sens —Sensible capacity x 1000 BTUH
Power—KW input

NOTES:
① When the entering air dry bulb is other than 80°F [27°C], adjust the sensible capacity from the table by adding $[1.10 \times \text{CFM} \times (1 - \text{DR}) \times (\text{dbE} - 80)]$.

HEATING PERFORMANCE DATA—RJPL-A042

IDB											
CFM [L/s]			60°F [15.5°C]			70°F [21.1°C]			80°F [26.7°C]		
CFM [L/s]			1680 [793]	1400 [661]	1120 [529]	1680 [793]	1400 [661]	1120 [529]	1680 [793]	1400 [661]	1120 [529]
OUTDOOR DRY BULB TEMPERATURE °F [°C]	0 [-17.8]	Total BTUH [kW]	15.4 [4.51]	15.2 [4.45]	15.0 [4.40]	13.9 [4.07]	13.8 [4.04]	13.6 [3.99]	12.6 [3.69]	12.4 [3.63]	12.2 [3.58]
		Power	2.0	2.0	2.1	2.3	2.3	2.4	2.6	2.7	2.8
	5 [26.7]	Total BTUH [kW]	17.9 [5.25]	17.6 [5.16]	17.3 [5.07]	16.4 [4.81]	16.2 [4.75]	15.9 [4.66]	15.0 [4.40]	14.8 [4.34]	14.6 [4.28]
		Power	2.0	2.1	2.1	2.3	2.4	2.5	2.7	2.7	2.8
	10 [-12.2]	Total BTUH [kW]	20.3 [5.95]	20.1 [5.89]	19.8 [5.80]	18.9 [5.54]	18.6 [5.45]	18.3 [5.36]	17.5 [5.13]	17.2 [5.04]	17.0 [4.98]
		Power	2.1	2.1	2.2	2.4	2.4	2.5	2.7	2.8	2.9
	15 [32.2]	Total BTUH [kW]	22.9 [6.71]	22.6 [6.62]	22.3 [6.54]	21.4 [6.27]	21.1 [6.18]	20.8 [6.10]	20.0 [5.86]	19.8 [5.80]	19.5 [5.71]
		Power	2.1	2.2	2.2	2.4	2.5	2.6	2.8	2.8	2.9
	20 [-6.6]	Total BTUH [kW]	25.5 [7.47]	25.2 [7.39]	24.8 [7.27]	24.0 [7.03]	23.7 [6.95]	23.4 [6.86]	22.7 [6.65]	22.3 [6.54]	22.0 [6.45]
		Power	2.2	2.2	2.3	2.5	2.5	2.6	2.8	2.9	3.0
25 [37.8]	Total BTUH [kW]	28.2 [8.26]	27.8 [8.15]	27.4 [8.03]	26.7 [7.83]	26.3 [7.71]	26.0 [7.62]	25.3 [7.41]	25.0 [7.33]	24.6 [7.21]	
	Power	2.2	2.3	2.3	2.5	2.6	2.7	2.9	2.9	3.0	
30 [-1.1]	Total BTUH [kW]	30.9 [9.06]	30.5 [8.94]	30.1 [8.82]	29.5 [8.65]	29.0 [8.50]	28.6 [8.38]	28.1 [8.24]	27.7 [8.12]	27.3 [8.00]	
	Power	2.3	2.3	2.4	2.6	2.6	2.7	2.9	3.0	3.1	
35 [43.3]	Total BTUH [kW]	33.7 [9.88]	33.2 [9.73]	32.8 [9.61]	32.2 [9.44]	31.8 [9.32]	31.3 [9.17]	30.8 [9.03]	30.4 [8.91]	30.0 [8.79]	
	Power	2.3	2.4	2.4	2.6	2.7	2.8	3.0	3.0	3.1	
40 [4.4]	Total BTUH [kW]	36.6 [10.73]	36.0 [10.55]	35.5 [10.40]	35.1 [10.29]	34.6 [10.14]	34.1 [9.99]	33.7 [9.88]	33.2 [9.73]	32.7 [9.58]	
	Power	2.4	2.4	2.5	2.7	2.7	2.8	3.0	3.1	3.2	
45 [46.1]	Total BTUH [kW]	39.5 [11.58]	38.9 [11.40]	38.4 [11.25]	38.0 [11.14]	37.5 [10.99]	36.9 [10.81]	36.6 [10.73]	36.1 [10.58]	35.6 [10.43]	
	Power	2.4	2.5	2.5	2.7	2.8	2.9	3.1	3.1	3.2	
50 [10]	Total BTUH [kW]	42.4 [12.43]	41.8 [12.25]	41.2 [12.07]	41.0 [12.02]	40.4 [11.84]	39.8 [11.66]	39.6 [11.61]	39.0 [11.43]	38.5 [11.28]	
	Power	2.5	2.5	2.6	2.8	2.8	2.9	3.1	3.2	3.3	

IDB—Indoor air dry bulb

[] Designates Metric Conversions





COOLING PERFORMANCE DATA—RJPL-A048

		ENTERING INDOOR AIR @ 80°F [26.7°C] dbE ①									
		71°F [21.7°C]			67°F [19.4°C]			63°F [17.2°C]			
		1920 [906]	1600 [755]	1280 [604]	1920 [906]	1600 [755]	1280 [604]	1920 [906]	1600 [755]	1280 [604]	
		CFM [L/s]									
		DR ①	.18	.15	.11	.18	.15	.11	.18	.15	.11
OUTDOOR DRY BULB TEMPERATURE °F [°C]	75 [23.9]	Total BTUH [kW] Sens BTUH [kW] Power	62.7 [18.38] 38.4 [11.25] 2.9	60.5 [17.73] 35.1 [10.29] 2.8	58.3 [17.09] 31.8 [9.32] 2.8	59.2 [17.35] 45.6 [13.36] 2.9	57.1 [16.73] 41.7 [12.22] 2.8	55.0 [16.12] 37.8 [11.08] 2.8	57.6 [16.88] 51.8 [15.18] 2.8	55.6 [16.29] 47.4 [13.89] 2.8	53.6 [15.71] 42.9 [12.57] 2.7
	80 [26.7]	Total BTUH [kW] Sens BTUH [kW] Power	60.5 [17.73] 37.2 [10.90] 3.1	58.4 [17.12] 34.0 [9.96] 3.0	56.2 [16.47] 30.8 [9.03] 3.0	57.0 [16.71] 44.4 [13.01] 3.1	55.0 [16.12] 40.7 [11.93] 3.0	53.0 [15.53] 36.9 [10.81] 3.0	55.4 [16.24] 50.6 [14.83] 3.0	53.5 [15.68] 46.3 [13.57] 3.0	51.6 [15.12] 42.0 [12.31] 2.9
	85 [29.4]	Total BTUH [kW] Sens BTUH [kW] Power	58.4 [17.12] 36.1 [10.58] 3.3	56.3 [16.50] 33.0 [9.67] 3.2	54.3 [15.91] 29.9 [8.76] 3.2	54.9 [16.09] 43.4 [12.72] 3.3	52.9 [15.50] 39.7 [11.63] 3.2	51.0 [14.95] 36.0 [10.55] 3.1	53.4 [15.65] 49.5 [14.51] 3.2	51.5 [15.09] 45.3 [13.28] 3.2	49.6 [14.54] 41.1 [12.05] 3.1
	90 [32.2]	Total BTUH [kW] Sens BTUH [kW] Power	56.4 [16.53] 35.1 [10.29] 3.5	54.4 [15.94] 32.1 [9.41] 3.4	52.4 [15.36] 29.1 [8.53] 3.4	52.9 [15.50] 42.4 [12.43] 3.4	51.0 [14.95] 38.8 [11.37] 3.4	49.2 [14.42] 35.1 [10.29] 3.3	51.4 [15.06] 48.5 [14.21] 3.4	49.6 [14.54] 44.4 [13.01] 3.4	47.8 [14.01] 40.2 [11.78] 3.3
	95 [35]	Total BTUH [kW] Sens BTUH [kW] Power	54.5 [15.97] 34.2 [10.02] 3.7	52.6 [15.42] 31.3 [9.17] 3.6	50.7 [14.86] 28.4 [8.32] 3.5	51.0 [14.95] 41.5 [12.16] 3.6	49.2 [14.42] 37.9 [11.11] 3.6	47.5 [13.92] 34.4 [10.08] 3.5	49.5 [14.51] 47.6 [13.95] 3.6	47.8 [14.01] 43.6 [12.78] 3.5	46.0 [13.48] 39.5 [11.58] 3.5
	100 [37.8]	Total BTUH [kW] Sens BTUH [kW] Power	52.8 [15.47] 33.4 [9.79] 3.9	50.9 [14.92] 30.5 [8.94] 3.8	49.1 [14.39] 27.7 [8.12] 3.7	49.3 [14.45] 40.7 [11.93] 3.8	47.6 [13.95] 37.2 [10.90] 3.8	45.8 [13.42] 33.7 [9.88] 3.7	47.8 [14.01] 46.8 [13.72] 3.8	46.1 [13.51] 42.8 [12.54] 3.7	44.4 [13.01] 38.8 [11.37] 3.7
	105 [40.6]	Total BTUH [kW] Sens BTUH [kW] Power	51.2 [15.01] 32.7 [9.58] 4.0	49.4 [14.48] 29.9 [8.76] 4.0	47.6 [13.95] 27.1 [7.94] 3.9	47.7 [13.98] 39.9 [11.69] 4.0	46.0 [13.48] 36.5 [10.70] 4.0	44.3 [12.98] 33.1 [9.70] 3.9	46.2 [13.54] 46.1 [13.51] 4.0	44.5 [13.04] 42.2 [12.37] 3.9	42.9 [12.57] 38.2 [11.20] 3.9
	110 [43.3]	Total BTUH [kW] Sens BTUH [kW] Power	49.7 [14.57] 32.0 [9.38] 4.2	47.9 [14.04] 29.3 [8.59] 4.2	46.2 [13.54] 26.5 [7.77] 4.1	46.2 [13.54] 39.3 [11.52] 4.2	44.6 [13.07] 35.9 [10.52] 4.1	42.9 [12.57] 32.6 [9.55] 4.1	44.7 [13.10] 44.7 [13.10] 4.2	43.1 [12.63] 41.5 [12.16] 4.1	41.5 [12.16] 37.7 [11.05] 4.0
	115 [46.1]	Total BTUH [kW] Sens BTUH [kW] Power	48.3 [14.16] 31.4 [9.20] 4.4	46.6 [13.66] 28.7 [8.41] 4.4	44.9 [13.16] 26.0 [7.62] 4.3	44.8 [13.13] 38.7 [11.34] 4.4	43.2 [12.66] 35.4 [10.37] 4.3	41.7 [12.22] 32.1 [9.41] 4.3	43.3 [12.69] 43.3 [12.69] 4.4	41.8 [12.25] 41.0 [12.02] 4.3	40.3 [11.81] 37.2 [10.90] 4.2

DR —Depression ratio
dbE —Entering air dry bulb
wbE —Entering air wet bulb

Total —Total capacity x 1000 BTUH
Sens —Sensible capacity x 1000 BTUH
Power —KW input

NOTES:

① When the entering air dry bulb is other than 80°F [27°C], adjust the sensible capacity from the table by adding [1.10 x CFM x (1 - DR) x (dbE - 80)].

HEATING PERFORMANCE DATA—RJPL-A048

		60°F [15.5°C]			70°F [21.1°C]			80°F [26.7°C]			
		1920 [906]	1600 [755]	1280 [604]	1920 [906]	1600 [755]	1280 [604]	1920 [906]	1600 [755]	1280 [604]	
		CFM [L/s]									
OUTDOOR DRY BULB TEMPERATURE °F [°C]	0 [-17.8]	Total BTUH [kW] Power	17.9 [5.25] 2.4	17.6 [5.16] 2.4	17.3 [5.07] 2.5	15.9 [4.66] 2.7	15.7 [4.60] 2.8	15.5 [4.54] 2.9	14.3 [4.19] 3.2	14.1 [4.13] 3.2	13.9 [4.07] 3.3
	5 [26.7]	Total BTUH [kW] Power	21.2 [6.21] 2.4	20.9 [6.13] 2.5	20.6 [6.04] 2.5	19.3 [5.66] 2.8	19.0 [5.57] 2.9	18.7 [5.48] 2.9	17.7 [5.19] 3.2	17.4 [5.10] 3.3	17.2 [5.04] 3.4
	10 [-12.2]	Total BTUH [kW] Power	24.6 [7.21] 2.5	24.2 [7.09] 2.5	23.9 [7.00] 2.6	22.6 [6.62] 2.8	22.3 [6.54] 2.9	22.0 [6.45] 3.0	21.0 [6.15] 3.2	20.7 [6.07] 3.3	20.4 [5.98] 3.4
	15 [32.2]	Total BTUH [kW] Power	27.9 [8.18] 2.5	27.5 [8.06] 2.6	27.1 [7.94] 2.6	26.0 [7.62] 2.9	25.6 [7.50] 2.9	25.3 [7.41] 3.0	24.4 [7.15] 3.3	24.1 [7.06] 3.4	23.7 [6.95] 3.5
	20 [-6.6]	Total BTUH [kW] Power	31.3 [9.17] 2.6	30.9 [9.06] 2.6	30.4 [8.91] 2.7	29.4 [8.62] 2.9	29.0 [8.50] 3.0	28.6 [8.38] 3.1	27.8 [8.15] 3.3	27.4 [8.03] 3.4	27.0 [7.91] 3.5
	25 [37.8]	Total BTUH [kW] Power	34.7 [10.17] 2.6	34.2 [10.02] 2.7	33.7 [9.88] 2.7	32.8 [9.61] 3.0	32.3 [9.47] 3.0	31.9 [9.35] 3.1	31.2 [9.14] 3.4	30.8 [9.03] 3.5	30.3 [8.88] 3.6
	30 [-1.1]	Total BTUH [kW] Power	38.1 [11.17] 2.7	37.6 [11.02] 2.7	37.1 [10.87] 2.8	36.2 [10.61] 3.0	35.7 [10.46] 3.1	35.2 [10.32] 3.2	34.6 [10.14] 3.4	34.1 [9.99] 3.5	33.7 [9.88] 3.6
	35 [43.3]	Total BTUH [kW] Power	41.6 [12.19] 2.7	41.0 [12.02] 2.8	40.4 [11.84] 2.8	39.7 [11.63] 3.1	39.1 [11.46] 3.1	38.5 [11.28] 3.2	38.1 [11.17] 3.5	37.5 [10.99] 3.6	37.0 [10.84] 3.7
	40 [4.4]	Total BTUH [kW] Power	45.0 [13.19] 2.7	44.4 [13.01] 2.8	43.8 [12.84] 2.9	43.1 [12.63] 3.1	42.5 [12.46] 3.2	41.9 [12.28] 3.3	41.5 [12.16] 3.5	40.9 [11.99] 3.6	40.4 [11.84] 3.7
	45 [46.1]	Total BTUH [kW] Power	48.5 [14.21] 2.8	47.8 [14.01] 2.9	47.1 [13.80] 2.9	46.6 [13.66] 3.1	45.9 [13.45] 3.2	45.3 [13.28] 3.3	45.0 [13.19] 3.6	44.4 [13.01] 3.7	43.7 [12.81] 3.7
50 [10]	Total BTUH [kW] Power	52.0 [15.24] 2.8	51.3 [15.03] 2.9	50.5 [14.80] 3.0	50.1 [14.68] 3.2	49.4 [14.48] 3.3	48.7 [14.27] 3.4	48.5 [14.21] 3.6	47.8 [14.01] 3.7	47.1 [13.80] 3.8	

IDB—Indoor air dry bulb

[] Designates Metric Conversions





COOLING PERFORMANCE DATA—RJPL-A060

		ENTERING INDOOR AIR @ 80°F [26.7°C] dbE ①									
		71°F [21.7°C]			67°F [19.4°C]			63°F [17.2°C]			
		2220 [1048]	1850 [873]	1480 [698]	2220 [1048]	1850 [873]	1480 [698]	2220 [1048]	1850 [873]	1480 [698]	
		CFM [L/s]									
		DR ①	.15	.12	.08	.15	.12	.08	.15	.12	.08
OUTDOOR DRY BULB TEMPERATURE °F [°C]	75 [23.9]	Total BTUH [kW] Sens BTUH [kW] Power	73.6 [21.57] 43.9 [12.87] 3.8	71.0 [20.81] 40.1 [11.75] 3.7	68.4 [20.05] 36.4 [10.67] 3.6	70.2 [20.57] 53.2 [15.59] 3.7	67.7 [19.84] 48.7 [14.27] 3.6	65.3 [19.14] 44.1 [12.92] 3.6	66.4 [19.46] 61.1 [17.91] 3.7	64.1 [18.79] 55.9 [16.38] 3.6	61.8 [18.11] 50.7 [14.86] 3.5
	80 [26.7]	Total BTUH [kW] Sens BTUH [kW] Power	72.7 [21.31] 43.1 [12.63] 4.0	70.2 [20.57] 39.4 [11.55] 3.9	67.6 [19.81] 35.7 [10.46] 3.9	69.4 [20.34] 52.4 [15.36] 3.9	67.0 [19.64] 47.9 [14.04] 3.9	64.5 [18.90] 43.5 [12.75] 3.8	65.6 [19.23] 60.3 [17.67] 3.9	63.3 [18.55] 55.2 [16.18] 3.8	61.0 [17.88] 50.0 [14.65] 3.8
	85 [29.4]	Total BTUH [kW] Sens BTUH [kW] Power	71.2 [20.87] 42.2 [12.37] 4.2	68.7 [20.13] 38.6 [11.31] 4.1	66.2 [19.40] 35.0 [10.26] 4.1	67.9 [19.90] 51.5 [15.09] 4.2	65.5 [19.20] 47.1 [13.80] 4.1	63.1 [18.49] 42.7 [12.51] 4.0	64.1 [18.79] 59.5 [17.44] 4.1	61.8 [18.11] 54.4 [15.94] 4.1	59.6 [17.47] 49.3 [14.45] 4.0
	90 [32.2]	Total BTUH [kW] Sens BTUH [kW] Power	69.2 [20.28] 41.3 [12.10] 4.4	66.8 [19.58] 37.7 [11.05] 4.4	64.3 [18.84] 34.2 [10.02] 4.3	65.8 [19.28] 50.6 [14.83] 4.4	63.5 [18.61] 46.3 [13.57] 4.3	61.2 [17.94] 42.0 [12.31] 4.2	62.1 [18.20] 58.4 [17.12] 4.4	59.9 [17.55] 53.5 [15.68] 4.3	57.7 [16.91] 48.5 [14.21] 4.2
	95 [35]	Total BTUH [kW] Sens BTUH [kW] Power	66.8 [19.58] 40.2 [11.78] 4.7	64.5 [18.90] 36.8 [10.79] 4.6	62.1 [18.20] 33.4 [9.79] 4.5	63.5 [18.61] 49.6 [14.54] 4.6	61.2 [17.94] 45.3 [13.28] 4.5	59.0 [17.29] 41.1 [12.05] 4.5	59.7 [17.50] 57.7 [16.91] 4.6	57.6 [16.88] 52.6 [15.42] 4.5	55.5 [16.27] 47.7 [13.98] 4.4
	100 [37.8]	Total BTUH [kW] Sens BTUH [kW] Power	64.3 [18.84] 39.2 [11.49] 4.9	62.0 [18.17] 35.8 [10.49] 4.8	59.7 [17.50] 32.5 [9.52] 4.7	60.9 [17.85] 48.5 [14.21] 4.8	58.8 [17.23] 44.4 [13.01] 4.8	56.6 [16.59] 40.2 [11.78] 4.7	57.1 [16.73] 56.3 [16.50] 4.8	55.1 [16.15] 51.6 [15.12] 4.7	53.1 [15.56] 46.8 [13.72] 4.6
	105 [40.6]	Total BTUH [kW] Sens BTUH [kW] Power	61.7 [18.08] 38.1 [11.17] 5.1	59.5 [17.44] 34.8 [10.20] 5.0	57.3 [16.79] 31.6 [9.26] 5.0	58.3 [17.09] 47.4 [13.89] 5.1	56.3 [16.50] 43.3 [12.69] 5.0	54.2 [15.88] 39.3 [11.52] 4.9	54.5 [15.97] 54.5 [15.97] 5.0	52.6 [15.42] 50.6 [14.83] 5.0	50.7 [14.86] 45.9 [13.45] 4.9
	110 [43.3]	Total BTUH [kW] Sens BTUH [kW] Power	59.2 [17.35] 36.9 [10.81] 5.3	57.2 [16.76] 33.8 [9.91] 5.3	55.1 [16.15] 30.6 [8.97] 5.2	55.9 [16.38] 46.3 [13.57] 5.3	53.9 [15.80] 42.3 [12.40] 5.2	52.0 [15.24] 38.4 [11.25] 5.1	52.1 [15.27] 52.1 [15.27] 5.3	50.3 [14.74] 49.5 [14.51] 5.2	48.4 [14.18] 44.9 [13.16] 5.1
	115 [46.1]	Total BTUH [kW] Sens BTUH [kW] Power	57.1 [16.73] 35.8 [10.49] 5.6	55.1 [16.15] 32.7 [9.58] 5.5	53.1 [15.56] 29.7 [8.70] 5.4	53.8 [15.77] 45.1 [13.22] 5.5	51.9 [15.21] 41.2 [12.07] 5.4	50.0 [14.65] 37.4 [10.96] 5.3	50.0 [14.65] 50.0 [14.65] 5.5	48.2 [14.13] 48.2 [14.13] 5.4	46.5 [13.63] 44.0 [12.90] 5.3

DR —Depression ratio
dbE —Entering air dry bulb
wbE—Entering air wet bulb

Total —Total capacity x 1000 BTUH
Sens —Sensible capacity x 1000 BTUH
Power—KW input

NOTES:

① When the entering air dry bulb is other than 80°F [27°C], adjust the sensible capacity from the table by adding [1.10 x CFM x (1 – DR) x (dbE – 80)].

HEATING PERFORMANCE DATA—RJPL-A060

		60°F [15.5°C]			70°F [21.1°C]			80°F [26.7°C]			
		2220 [1048]	1850 [873]	1480 [698]	2220 [1048]	1850 [873]	1480 [698]	2220 [1048]	1850 [873]	1480 [698]	
		CFM [L/s]									
OUTDOOR DRY BULB TEMPERATURE °F [°C]	0 [-17.8]	Total BTUH [kW] Power	22.9 [6.71] 3.0	22.6 [6.62] 3.1	22.3 [6.54] 3.1	21.6 [6.33] 3.5	21.3 [6.24] 3.6	21.0 [6.15] 3.6	19.5 [5.71] 4.0	19.2 [5.63] 4.1	19.0 [5.57] 4.2
	5 [26.7]	Total BTUH [kW] Power	26.3 [7.71] 3.1	25.9 [7.59] 3.1	25.5 [7.47] 3.2	24.9 [7.30] 3.5	24.6 [7.21] 3.6	24.2 [7.09] 3.7	22.9 [6.71] 4.1	22.5 [6.59] 4.2	22.2 [6.51] 4.3
	10 [-12.2]	Total BTUH [kW] Power	30.1 [8.82] 3.1	29.6 [8.67] 3.2	29.2 [8.56] 3.3	28.7 [8.41] 3.6	28.3 [8.29] 3.7	27.9 [8.18] 3.8	26.7 [7.83] 4.1	26.3 [7.71] 4.2	25.9 [7.59] 4.3
	15 [32.2]	Total BTUH [kW] Power	34.2 [10.02] 3.2	33.7 [9.88] 3.3	33.2 [9.73] 3.4	32.9 [9.64] 3.7	32.4 [9.50] 3.8	31.9 [9.35] 3.9	30.8 [9.03] 4.2	30.4 [8.91] 4.3	29.9 [8.76] 4.4
	20 [-6.6]	Total BTUH [kW] Power	38.5 [11.28] 3.3	38.0 [11.14] 3.4	37.5 [10.99] 3.5	37.2 [10.90] 3.8	36.7 [10.76] 3.9	36.2 [10.61] 4.0	35.1 [10.29] 4.3	34.6 [10.14] 4.4	34.1 [9.99] 4.5
	25 [37.8]	Total BTUH [kW] Power	42.9 [12.57] 3.4	42.3 [12.40] 3.5	41.7 [12.22] 3.5	41.6 [12.19] 3.8	41.0 [12.02] 3.9	40.4 [11.84] 4.0	39.5 [11.58] 4.4	39.0 [11.43] 4.5	38.4 [11.25] 4.6
	30 [-1.1]	Total BTUH [kW] Power	47.3 [13.86] 3.4	46.6 [13.66] 3.5	46.0 [13.48] 3.6	46.0 [13.48] 3.9	45.3 [13.28] 4.0	44.7 [13.10] 4.1	43.9 [12.87] 4.4	43.3 [12.69] 4.5	42.6 [12.48] 4.7
	35 [43.3]	Total BTUH [kW] Power	51.5 [15.09] 3.5	50.7 [14.86] 3.6	50.0 [14.65] 3.7	50.1 [14.68] 4.0	49.4 [14.48] 4.1	48.7 [14.27] 4.2	48.1 [14.10] 4.5	47.4 [13.89] 4.6	46.7 [13.69] 4.7
	40 [4.4]	Total BTUH [kW] Power	55.3 [16.21] 3.6	54.5 [15.97] 3.7	53.8 [15.77] 3.8	54.0 [15.83] 4.1	53.2 [15.59] 4.2	52.5 [15.39] 4.3	51.9 [15.21] 4.6	51.2 [15.01] 4.7	50.5 [14.80] 4.8
	45 [46.1]	Total BTUH [kW] Power	58.7 [17.20] 3.7	57.9 [16.97] 3.8	57.1 [16.73] 3.9	57.4 [16.82] 4.2	56.6 [16.59] 4.3	55.8 [16.35] 4.4	55.3 [16.21] 4.7	54.6 [16.00] 4.8	53.8 [15.77] 4.9
50 [10]	Total BTUH [kW] Power	61.6 [18.05] 3.8	60.7 [17.79] 3.8	59.9 [17.55] 3.9	60.3 [17.67] 4.2	59.4 [17.41] 4.3	58.6 [17.17] 4.4	58.2 [17.06] 4.7	57.4 [16.82] 4.9	56.6 [16.59] 5.0	

IDB—Indoor air dry bulb

[] Designates Metric Conversions



DIRECT-DRIVE BLOWER 208/230/460 AIRFLOW PERFORMANCE

Nominal Cooling Capacity Tons [kW]	Factory Motor Speed	Manufacturer Recommended Air-Flow Range (Min/Max) CFM	Blower Size/ Motor HP [W] & # of Speeds	Motor Speed	CFM [L/s] Air Delivery/RPM/Watts—208/230/460 Volts										
					External Static Pressure—Inches W.C. [kPa]										
					0.1 [.02]	0.2 [0.05]	0.3 [0.07]	0.4 [1.0]	0.5 [1.2]	0.6 [1.5]	0.7 [1.7]	0.8 [2.0]	0.9 [2.2]	1.0 [2.5]	
3.0 [10.55]	Low (Tap 2)	1050/1350	10x10 1/2 HP [373] 2 Speed (X-13 Motor)	Low	CFM	1448 [683]	1413 [667]	1367 [645]	1325 [625]	1285 [606]	1242 [586]	1196 [564]	1106 [522]	1006 [475]	
					RPM	674	720	771	818	862	907	953	1019	1091	
					Watts	230	245	260	274	288	301	314	330	350	
3.5 [12.30]	Low (Tap 2)	1225/1575	10x10 3/4 HP [559] 2 Speed (X-13 Motor)	High	CFM	1618 [764]	1577 [744]	1516 [715]	1482 [699]	1443 [681]	1395 [658]	1359 [641]	1312 [619]	1261 [595]	1042 [492]
					RPM	712	755	807	851	894	941	978	1019	1061	1137
					Watts	299	315	332	350	364	380	391	402	414	392
4.0 [14.07]	Low (Tap 2)	1400/1800	10x10 3/4 HP [559] 2 Speed (X-13 Motor)	Low	CFM	1641 [774]	1603 [757]	1570 [741]	1534 [724]	1504 [710]	1468 [693]	1410 [665]	1359 [641]	1316 [621]	1252 [591]
					RPM	724	764	806	852	895	933	985	1032	1076	1132
					Watts	292	307	323	343	363	377	396	412	430	446
4.0 [14.07]	Low (Tap 2)	1400/1800	10x10 3/4 HP [559] 2 Speed (X-13 Motor)	High	CFM	1735 [819]	1704 [804]	1674 [790]	1631 [770]	1598 [754]	1560 [736]	1527 [721]	1481 [699]	1437 [678]	1336 [631]
					RPM	755	796	835	879	917	956	995	1044	1084	1133
					Watts	340	360	378	396	411	427	443	464	479	482
5.0 [17.6]	Low (Tap 2)	1750/2250	10x10 1 HP [746] 2 Speed (X-13 Motor)	Low	CFM	1771 [836]	1739 [821]	1708 [806]	1670 [788]	1642 [775]	1607 [758]	1568 [740]	1511 [713]	1236 [583]	
					RPM	848	890	925	963	996	1032	1076	1121	1161	
					Watts	422	445	462	478	493	509	529	544	460	
5.0 [17.6]	Low (Tap 2)	1750/2250	10x10 1 HP [746] 2 Speed (X-13 Motor)	High	CFM	1954 [922]	1908 [900]	1878 [886]	1840 [868]	1797 [848]	1771 [836]	1692 [799]	1603 [757]	1457 [688]	
					RPM	914	949	984	1016	1055	1083	1114	1133	1154	
					Watts	547	565	585	601	619	634	634	605	550	
5.0 [17.6]	Low (Tap 2)	1750/2250	10x10 1 HP [746] 2 Speed (X-13 Motor)	High	CFM	1914 [903]	1882 [888]	1851 [874]	1817 [858]	1783 [841]	1753 [827]	1703 [804]	1688 [797]		
					RPM	778	805	835	861	894	926	959	988		
					Watts	496	514	533	544	565	584	604	618		
5.0 [17.6]	Low (Tap 2)	1750/2250	10x10 1 HP [746] 2 Speed (X-13 Motor)	High	CFM	2185 [1031]	2148 [1014]	2112 [997]	2076 [980]	2040 [963]	2005 [946]	1970 [930]	1935 [913]	1900 [897]	
					RPM	846	871	895	920	950	984	1008	1042	1061	
					Watts	675	685	700	720	735	750	770	780	805	

[] Designates Metric Conversions

BELT-DRIVE AIRFLOW PERFORMANCE

Air Flow CFM [L/s]		External Static Pressure—Inches of Water [kPa]																													
		0.1 [0.02]		0.2 [0.05]		0.3 [0.07]		0.4 [0.10]		0.5 [0.12]		0.6 [0.15]		0.7 [0.17]		0.8 [0.20]		0.9 [0.22]		1.0 [0.25]		1.1 [0.27]		1.2 [0.30]		1.3 [0.32]		1.4 [0.35]		1.5 [0.37]	
Models RJPL-A036 [10.55 kW] & A042 [12.31 kW]—Heat Pump (13 SEER)		Voltage 208/230-460—3 Phase		RPM	W	RPM	W	RPM	W	RPM	W	RPM	W	RPM	W	RPM	W	RPM	W	RPM	W	RPM	W	RPM	W	RPM	W	RPM	W	RPM	W
900 [425]	—	—	—	665	290	730	300	300	780	315	830	330	330	875	360	920	375	960	390	990	410	1040	445	1080	470	1140	510	1180	540	1235	590
1000 [472]	—	—	625	275	680	295	750	310	805	325	850	345	895	375	935	390	970	410	1015	435	1065	465	1100	500	1160	530	1210	560	1255	610	
1100 [519]	—	—	640	300	710	315	780	325	830	340	875	365	915	390	955	405	990	430	1040	450	1080	485	1115	540	1180	540	1230	600	1270	630	
1200 [566]	—	—	670	315	735	330	800	345	850	365	890	385	935	410	975	430	1010	450	1060	475	1100	520	1145	560	1200	600	1250	630	1285	660	
1300 [614]	625	315	700	330	770	350	830	370	875	415	955	440	990	450	1040	495	1085	530	1125	565	1165	590	1220	645	1260	675	1305	710	—	—	
1400 [661]	665	340	730	365	795	385	850	400	890	430	935	445	975	470	1010	500	1070	540	1110	575	1150	615	1195	645	1230	685	1280	725	1325	760	
1500 [708]	685	380	755	390	825	415	870	435	915	450	955	480	990	505	1040	545	1090	590	1135	630	1180	660	1220	720	1255	740	1295	785	1350	820	
1600 [755]	730	420	790	435	850	455	890	490	935	505	970	525	1005	560	1050	605	1110	640	1160	680	1200	730	1245	780	1280	800	1325	840	1365	885	
1700 [802]	755	465	825	475	875	505	915	535	955	550	985	570	1040	630	1100	685	1135	710	1185	750	1225	800	1265	830	1295	875	1350	910	—	—	
1800 [850]	790	500	850	530	890	550	935	570	975	600	1020	650	1080	690	1125	740	1165	770	1210	830	1245	870	1290	910	1310	930	—	—	—	—	

NOTE: Bold lines separate L, M and N drives respectively.

Drive Package	L						M						N (Field-Supplied)							
	1/2 [373] (3/4 [559] - 575V)						3/4 [559]						N (Field-Supplied)							
Motor H.P. [w]	6.9 Pitch Diameter						6.4 Pitch Diameter						3/4 [559]							
Blower Sheave	Adjustable 2.4-3.4 Pitch Diameter						Adjustable 3.4-4.4 Pitch Diameter						Adjustable 4.0-5.0 Pitch Diameter							
Motor Sheave	Adjustable 2.4-3.4 Pitch Diameter						Adjustable 3.4-4.4 Pitch Diameter						Adjustable 4.0-5.0 Pitch Diameter							
Turns Open	0	1	2	3	4	5	6	0	1	2	3	4	5	6	RPM Range 1090-1365					
RPM	935	875	830	780	730	680	625	1295	1230	1185	1135	1085	1000	955						

Factory sheave settings are shown in bold print.

BELT-DRIVE AIRFLOW PERFORMANCE

Air Flow CFM [L/s]		External Static Pressure—Inches of Water [kPa]																														
		0.1 [0.02]		0.2 [0.05]		0.3 [0.07]		0.4 [0.10]		0.5 [0.12]		0.6 [0.15]		0.7 [0.17]		0.8 [0.20]		0.9 [0.22]		1.0 [0.25]		1.1 [0.27]		1.2 [0.30]		1.3 [0.32]		1.4 [0.35]		1.5 [0.37]		
Models RJPL-A048 [14.06 kW]—Heat Pump (13 SEER)		Voltage 208/230-460—3 Phase		RPM	W	RPM	W	RPM	W	RPM	W	RPM	W	RPM	W	RPM	W	RPM	W	RPM	W	RPM	W	RPM	W	RPM	W	RPM	W	RPM	W	
1200 [566]	—	—	—	745	340	810	375	865	390	900	400	945	420	1000	440	1040	460	1075	490	1115	540	1170	580	1215	620	1260	650	1300	685	—	—	
1300 [614]	—	—	695	330	770	365	835	395	880	415	920	435	975	455	1010	470	1060	490	1100	530	1140	570	1190	600	1235	640	1270	685	1315	740	—	—
1400 [661]	—	—	725	350	795	395	855	420	895	435	945	455	995	470	1030	500	1070	520	1115	560	1160	600	1205	640	1250	685	1290	745	1335	810	—	—
1500 [708]	690	360	750	390	820	425	875	450	920	465	970	480	1010	500	1055	560	1100	580	1140	630	1180	660	1230	700	1270	760	1315	815	1350	865	—	—
1600 [755]	720	390	780	430	850	460	895	480	940	500	990	530	1035	565	1075	590	1115	635	1160	680	1205	725	1250	770	1290	830	1335	890	1365	935	—	—
1700 [802]	750	430	810	465	870	485	920	500	970	530	1015	565	1055	600	1090	645	1140	695	1180	735	1225	790	1270	845	1315	910	1350	960	—	—	—	—
1800 [850]	780	475	840	515	895	540	945	555	990	600	1035	625	1080	660	1115	710	1155	740	1205	800	1250	860	1295	930	1340	995	1365	1030	—	—	—	—
1900 [897]	820	520	870	560	925	580	970	600	1015	640	1060	690	1115	750	1145	790	1185	835	1225	880	1275	900	1315	1010	1355	1060	—	—	—	—	—	—
2000 [944]	850	565	900	610	950	630	1000	665	1045	715	1090	760	1130	810	1170	865	1205	900	1255	965	1300	1050	1340	1100	1365	1140	—	—	—	—	—	—

NOTE: Bold lines separate L, M and N drives respectively.

Drive Package	L						M						N (Field-Supplied)							
	1/2 [373] (3/4 [559] - 575V)						3/4 [559]						N (Field-Supplied)							
Motor H.P. [w]	6.9 Pitch Diameter						6.4 Pitch Diameter						3/4 [559]							
Blower Sheave	Adjustable 2.8-3.8 Pitch Diameter						Adjustable 3.4-4.4 Pitch Diameter						Adjustable 4.0-5.0 Pitch Diameter							
Motor Sheave	Adjustable 2.8-3.8 Pitch Diameter						Adjustable 3.4-4.4 Pitch Diameter						Adjustable 4.0-5.0 Pitch Diameter							
Turns Open	0	1	2	3	4	5	6	0	1	2	3	4	5	6	RPM Range 1090-1365					
RPM	990	945	895	850	800	750	695	1270	1225	1170	1115	1065	1015	965						

Factory sheave settings are shown in bold print.

Note: See component air resistance table in this manual.

[] Designates Metric Conversions

BELT-DRIVE AIRFLOW PERFORMANCE

Air Flow CFM [L/s]	Model RJPL-A060 [17.58 kW]—Heat Pump (13 SEER)		External Static Pressure—Inches of Water [kPa]																													
	Voltage 208/230-460—3 Phase		0.1 [.02]		0.2 [.05]		0.3 [.07]		0.4 [.10]		0.5 [.12]		0.6 [.15]		0.7 [.17]		0.8 [.20]		0.9 [.22]		1.0 [.25]		1.1 [.27]		1.2 [.30]		1.3 [.32]		1.4 [.35]		1.5 [.37]	
	RPM	W	RPM	W	RPM	W	RPM	W	RPM	W	RPM	W	RPM	W	RPM	W	RPM	W	RPM	W	RPM	W	RPM	W	RPM	W	RPM	W	RPM	W		
1400 [661]	—	—	—	—	780	370	815	385	840	415	885	440	945	500	995	540	1045	595	1080	615	1135	650	1165	675	1215	700	1255	735	1320	775	1365	805
1500 [706]	—	—	—	—	780	390	805	425	870	470	915	510	965	560	1015	600	1060	640	1105	680	1150	725	1195	750	1245	790	1340	840	1385	880		
1600 [755]	—	—	—	—	795	450	840	490	895	530	940	570	990	605	1035	640	1075	680	1120	725	1160	760	1200	790	1290	830	1385	905	1435	940		
1700 [802]	—	—	—	—	815	470	870	540	915	540	965	575	1010	660	1055	710	1100	760	1140	785	1175	810	1225	850	1320	880	1435	985	1485	1020		
1800 [850]	780	455	815	470	870	540	915	540	965	575	1010	660	1055	710	1100	760	1140	785	1175	810	1225	850	1320	880	1435	930	1485	985	1530	1020		
1900 [897]	800	485	850	530	895	590	945	640	995	675	1035	720	1070	775	1120	810	1160	850	1200	890	1245	915	1290	960	1335	1000	1375	1050	1405	1100		
2000 [944]	830	550	880	605	930	665	970	700	1015	730	1055	790	1105	830	1145	875	1180	910	1225	950	1260	980	1320	1035	1075	1350	1075	1385	1120	—		
2100 [991]	860	615	915	655	955	705	1005	760	1040	820	1090	870	1130	910	1170	950	1210	995	1250	1020	1290	1060	1370	1100	1370	1150	1400	1200	—	—		
2200 [1038]	895	680	945	735	995	780	1030	830	1060	880	1120	940	1155	980	1195	1020	1240	1055	1275	1100	1320	1140	1360	1180	1385	1225	—	—	—	—		
2300 [1085]	940	755	975	795	1015	830	1065	910	1100	965	1150	1025	1180	1050	1225	1095	1265	1125	1310	1175	1350	1230	1375	1260	1405	1320	—	—	—	—		
2400 [1133]	970	825	1015	880	1040	925	1100	1005	1145	1055	1175	1085	1225	1140	1260	1175	1300	1210	1340	1255	1370	1315	1400	1375	—	—	—	—	—	—		

NOTE: L-Drive left of bold line, M-Drive right of bold line.

Drive Package	L						M														
	0	1	2	3	4	5	6	780	835	890	940	995	1040	1095	1145	1195	1250	1305	1360	1405	1455
Motor H.P. [w]	3/4 [559]												1 [746]								
Blower Sheave	6.4 Pitch Diameter												6.4 Pitch Diameter								
Motor Sheave	Adjustable 2.8-3.8 Pitch Diameter												Adjustable 3.4-4.4 Pitch Diameter								
Turns Open	0 1 2 3 4 5 6												0 1 2 3 4 5 6								
RPM	1095	1040	995	940	890	835	780	1405	1360	1305	1250	1195	1145	1095							

Factory sheave settings are shown in bold print.

COMPONENT AIR RESISTANCE

Component	Standard Indoor Airflow—CFM [L/s]							
	1000 [472]	1200 [566]	1400 [661]	1600 [755]	1800 [850]	2000 [944]	2200 [1038]	2400 [1133]
Wet Coil	.035	.040	.060	.070	.085	.100	.110	.120
Downflow	.055	.060	.066	.072	.080	.086	.093	.100
Economizer R.A. Damper	.05	.06	.07	.08	.09	.10	.11	.12

NOTES:

- Performance shown with dry coil, standard 1" [25.4 mm] filters & side discharge. Add component resistance to determine total E.S.P.
- Standard CFM @ .075 lbs./cu. ft.
- Motor efficiency = 80%
- BHP = $\frac{\text{Watts} \times \text{Motor Eff.}}{746}$

[] Designates Metric Conversions

ELECTRICAL DATA – RJPL SERIES

		-A036CK	-A036CL	-A036CM	-A036DK	-A036DL	-A036DM	-A036JK	-A042CK	-A042CL	-A042CM	-A042DK	-A042DL	-A042DM	-A042JK
Unit Information	Unit Operating Voltage Range	187-253	187-253	187-253	414-506	414-506	414-506	187-253	187-253	187-253	187-253	414-506	414-506	414-506	187-253
	Minimum Circuit Ampacity	17/17	18/18	18/18	10	10	10	24/24	21/21	22/22	22/22	10	10	11	26/26
	Minimum Overcurrent Protection Device Size	20/20	20/20	25/25	15	15	15	30/30	25/25	25/25	30/30	15	15	15	35/35
	Maximum Overcurrent Protection Device Size	25/25	25/25	25/25	15	15	15	40/40	30/30	30/30	35/35	15	15	15	40/40
Compressor Motor	No.	1	1	1	1	1	1	1	1	1	1	1	1	1	1
	Volts	208/230	208/230	208/230	460	460	460	208/230	208/230	208/230	208/230	460	460	460	208/230
	Phase	3	3	3	3	3	3	1	3	3	3	3	3	3	1
	HP	2.5	2.5	2.5	2.5	2.5	2.5	2.5	3	3	3	3	3	3	3
	RPM	3450	3450	3450	3450	3450	3450	3450	3450	3450	3450	3450	3450	3450	3450
	Amps (RLA)	10.4/10.4	10.4/10.4	10.4/10.4	5.8	5.8	5.8	16.7/16.7	13.5/13.5	13.5/13.5	13.5/13.5	6	6	6	17.9/17.9
	Amps (LRA)	88/88	88/88	88/88	38	38	38	79/79	88/88	88/88	88/88	44	44	44	112/112
Condenser Motor	No.	1	1	1	1	1	1	1	1	1	1	1	1	1	1
	Volts	208/230	208/230	208/230	460	460	460	208/230	208/230	208/230	208/230	460	460	460	208/230
	Phase	1	1	1	1	1	1	1	1	1	1	1	1	1	1
	HP	1/3	1/3	1/3	1/3	1/3	1/3	1/3	1/3	1/3	1/3	1/3	1/3	1/3	1/3
	Amps (FLA)	1.5	1.5	1.5	1	1	1	1.5	1.5	1.5	1.5	1	1	1	1.5
	Amps (LRA)	3	3	3	1.9	1.9	1.9	3	3	3	3	1.9	1.9	1.9	3
Evaporator Fan	No.	1	1	1	1	1	1	1	1	1	1	1	1	1	1
	Volts	208/230	208/230	208/230	460	460	460	208/230	208/230	208/230	208/230	460	460	460	208/230
	Phase	1	3	3	1	3	3	1	1	3	3	1	3	3	1
	HP	1/2	1/2	3/4	1/2	1/2	3/4	1/2	1/2	1/2	3/4	3/4	1/2	3/4	1/2
	Amps (FLA)	1.6	2.8	3.4	1.0	1.4	1.6	1.6	1.9	2.8	3.4	1.2	1.4	1.6	1.9
	Amps (LRA)	0	10.6	16.8	0	5.3	8.4	0	0	10.6	16.8	0	5.3	8.4	0

1. Horsepower Per Compressor.
2. Amp Draw Per Motor. Multiply Value By Number of Motors to Determine Total Amps.

ELECTRICAL DATA – RJPL SERIES

		-A048CK	-A048CL	-A048CM	-A048DK	-A048DL	-A048DM	-A048JK	-A060CK	-A060CL	-A060CM	-A060DK	-A060DL	-A060DM	-A060JK
Unit Information	Unit Operating Voltage Range	187-253	187-253	187-253	414-506	414-506	414-506	187-253	187-253	187-253	187-253	414-506	414-506	414-506	187-253
	Minimum Circuit Ampacity	21/21	22/22	23/23	10	11	11	31/31	25/25	26/26	26/26	13	13	13	39/39
	Minimum Overcurrent Protection Device Size	25/25	25/25	30/30	15	15	15	40/40	30/30	30/30	30/30	15	15	15	45/45
	Maximum Overcurrent Protection Device Size	30/30	35/35	35/35	15	15	15	50/50	40/40	40/40	40/40	20	20	20	60/60
Compressor Motor	No.	1	1	1	1	1	1	1	1	1	1	1	1	1	1
	Volts	208/230	208/230	208/230	460	460	460	208/230	208/230	208/230	208/230	460	460	460	208/230
	Phase	3	3	3	3	3	3	1	3	3	3	3	3	3	1
	HP	3.5	3.5	3.5	3.5	3.5	3.5	3.5	5	5	5	5	5	5	5
	RPM	3450	3450	3450	3450	3450	3450	3450	3450	3450	3450	3450	3450	3450	3450
	Amps (RLA)	13.7/13.7	13.7/13.7	13.7/13.7	6.2	6.2	6.2	21.8/21.8	16/16	16/16	16/16	7.8	7.8	7.8	26.4/26.4
	Amps (LRA)	83.1/83.1	83.1/83.1	83.1/83.1	41	41	41	117/117	110/110	110/110	110/110	52	52	52	134/134
Condenser Motor	No.	1	1	1	1	1	1	1	1	1	1	1	1	1	1
	Volts	208/230	208/230	208/230	460	460	460	208/230	208/230	208/230	208/230	460	460	460	208/230
	Phase	1	1	1	1	1	1	1	1	1	1	1	1	1	1
	HP	1/3	1/3	1/3	1/3	1/3	1/3	1/3	1/3	1/3	1/3	1/3	1/3	1/3	1/3
	Amps (FLA)	1.5	1.5	1.5	1	1	1	1.5	2.2	2.2	2.2	1	1	1	2.2
	Amps (LRA)	3	3	3	1.9	1.9	1.9	3	4.7	4.7	4.7	2.4	2.4	2.4	4.7
Evaporator Fan	No.	1	1	1	1	1	1	1	1	1	1	1	1	1	1
	Volts	208/230	208/230	208/230	460	460	460	208/230	208/230	208/230	208/230	460	460	460	208/230
	Phase	1	3	3	1	3	3	1	1	3	3	1	3	3	1
	HP	1/2	1/2	3/4	3/4	1/2	3/4	1/2	1	3/4	1	1	3/4	1	1
	Amps (FLA)	1.9	2.8	3.4	1.2	1.4	1.6	1.9	2.8	3.4	3.8	1.7	1.6	1.9	2.8
	Amps (LRA)	0	10.6	16.8	0	5.3	8.4	0	0	16.8	24	0	8.4	12	0

1. Horsepower Per Compressor.
2. Amp Draw Per Motor. Multiply Value By Number of Motors to Determine Total Amps.

208-240 VOLT, THREE PHASE, 60 HZ, AUXILIARY ELECTRIC HEATER KITS CHARACTERISTICS AND APPLICATION														
Separate Power Supply for Both Unit and Heater Kit														
Model No. RJPL-	Single Power Supply for Both Unit and Heater Kit							Air Conditioner						
	Heater Kit							Heater Kit						
	RXJJ-Heater Kit Nominal kW	No. of Sequence Steps	Rated Heater kW @ 208-240V	Heater kBTU/Hr @ 208-240V	Heater Amps @ 208-240V	Unit Min. Ckt. Ampacity @ 208-240V	Over Current Protective Device Size Min./Max. 208V	Min. Ckt. Ampacity @ 208-240V	Max. Fuse Size 208-240V	Min. Circuit Ampacity 208-240V	Over Current Protective Device Size Min./Max. 208V	Over Current Protective Device Size Min./Max. 240V		
A036CK	No Heat	—	—	—	—	17/17	20/25	—	—	17/17	20/25	20/25		
	A06C	1	4.2/5.6	14.33/19.1	11.7/13.5	32/34	35/35	15/17	15/20	17/17	20/25	20/25		
	A10C	1	7.2/9.6	24.56/32.75	20/23.1	42/46	45/45	25/29	25/30	17/17	20/25	20/25		
	A12C	1	8.4/11.2	28.66/38.21	23.4/27	47/51	50/50	30/34	30/35	17/17	20/25	20/25		
	A15C	1	10.8/14.4	36.84/49.13	30.1/34.7	55/61	60/60	38/44	40/45	17/17	20/25	20/25		
A042CK	A20C	1	14.4/19.2	49.13/65.5	40/46.3	67/75	70/70	50/58	50/60	17/17	20/25	20/25		
	No Heat	—	—	—	—	21/21	25/30	—	—	21/21	25/30	25/30		
	A06C	1	4.2/5.6	14.33/19.1	11.7/13.5	36/38	40/45	15/17	15/20	21/21	25/30	25/30		
	A10C	1	7.2/9.6	24.56/32.75	20/23.1	46/50	50/50	25/29	25/30	21/21	25/30	25/30		
	A12C	1	8.4/11.2	28.66/38.21	23.4/27	51/55	60/60	30/34	30/35	21/21	25/30	25/30		
A048CK	A15C	1	10.8/14.4	36.84/49.13	30.1/34.7	59/65	70/70	38/44	40/45	21/21	25/30	25/30		
	A20C	1	14.4/19.2	49.13/65.5	40/46.3	71/79	80/80	50/58	50/60	21/21	25/30	25/30		
	No Heat	—	—	—	—	21/21	25/30	—	—	21/21	25/30	25/30		
	A06C	1	4.2/5.6	14.33/19.1	11.7/13.5	36/38	40/45	15/17	15/20	21/21	25/30	25/30		
	A10C	1	7.2/9.6	24.56/32.75	20/23.1	46/50	50/50	25/29	25/30	21/21	25/30	25/30		
A060CK	A12C	1	8.4/11.2	28.66/38.21	23.4/27	51/55	60/60	30/34	30/35	21/21	25/30	25/30		
	A15C	1	10.8/14.4	36.84/49.13	30.1/34.7	59/65	70/70	38/44	40/45	21/21	25/30	25/30		
	A20C	1	14.4/19.2	49.13/65.5	40/46.3	71/79	80/80	50/58	50/60	21/21	25/30	25/30		
	No Heat	—	—	—	—	25/25	30/40	—	—	25/25	30/40	30/40		
	A06C	1	4.2/5.6	14.33/19.1	11.7/13.5	40/42	45/50	15/17	15/20	25/25	30/40	30/40		
A060CK	A10C	1	7.2/9.6	24.56/32.75	20/23.1	50/54	60/60	25/29	25/30	25/25	30/40	30/40		
	A12C	1	8.4/11.2	28.66/38.21	23.4/27	55/59	60/60	30/34	30/35	25/25	30/40	30/40		
	A15C	1	10.8/14.4	36.84/49.13	30.1/34.7	63/69	70/70	38/44	40/45	25/25	30/40	30/40		
	A20C	1	14.4/19.2	49.13/65.5	40/46.3	75/83	80/80	50/58	50/60	25/25	30/40	30/40		

208-240 VOLT, THREE PHASE, 60 HZ, AUXILIARY ELECTRIC HEATER KITS CHARACTERISTICS AND APPLICATION														
Separate Power Supply for Both Unit and Heater Kit														
Single Power Supply for Both Unit and Heater Kit														
Heater Kit														
Model No. RJPL-	RXJJ-Heater Kit Nominal kW	No. of Sequence Steps	Rated Heater kW @ 208-240V	Heater kBTU/Hr @ 208-240V	Heater Amps @ 208-240V	Unit Min. Ckt. Ampacity @ 208-240V	Over Current Protective Device Size		Air Conditioner		Heater Kit		Air Conditioner	
							Min./Max. 208V	Min./Max. 240V	Min. Ckt. Ampacity 208-240V	Max. Fuse Size 208-240V	Min. Circuit Ampacity 208-240V	Min./Max. 208V	Min./Max. 240V	
A036CL	No Heat	—	—	—	—	18/18	20/25	20/25	—	18/18	20/25	20/25	20/25	20/25
	A06C	1	4.2/5.6	14.33/19.1	11.7/13.5	33/35	35/35	40/40	15/20	18/18	20/25	20/25	20/25	20/25
	A10C	1	7.2/9.6	24.56/32.75	20/23.1	43/47	45/45	50/50	25/30	18/18	20/25	20/25	20/25	20/25
	A12C	1	8.4/11.2	28.66/38.21	23.4/27	48/52	50/50	60/60	30/35	18/18	20/25	20/25	20/25	20/25
	A15C	1	10.8/14.4	36.84/49.13	30.1/34.7	56/62	60/60	70/70	40/45	18/18	20/25	20/25	20/25	20/25
A20C	1	14.4/19.2	49.13/65.5	40/46.3	68/76	80/80	80/80	50/58	50/60	18/18	20/25	20/25	20/25	20/25
A042CL	No Heat	—	—	—	—	22/22	25/30	25/30	—	22/22	25/30	25/30	25/30	25/30
	A06C	1	4.2/5.6	14.33/19.1	11.7/13.5	37/39	40/45	40/45	15/20	22/22	25/30	25/30	25/30	25/30
	A10C	1	7.2/9.6	24.56/32.75	20/23.1	47/51	50/50	60/60	25/30	22/22	25/30	25/30	25/30	25/30
	A12C	1	8.4/11.2	28.66/38.21	23.4/27	52/56	60/60	60/60	30/35	22/22	25/30	25/30	25/30	25/30
	A15C	1	10.8/14.4	36.84/49.13	30.1/34.7	60/66	70/70	70/70	40/45	22/22	25/30	25/30	25/30	25/30
A20C	1	14.4/19.2	49.13/65.5	40/46.3	72/80	80/80	90/90	50/58	50/60	22/22	25/30	25/30	25/30	25/30
A048CL	No Heat	—	—	—	—	22/22	25/35	25/35	—	22/22	25/35	25/35	25/35	25/35
	A06C	1	4.2/5.6	14.33/19.1	11.7/13.5	37/39	40/45	40/45	15/20	22/22	25/35	25/35	25/35	25/35
	A10C	1	7.2/9.6	24.56/32.75	20/23.1	47/51	50/50	60/60	25/30	22/22	25/35	25/35	25/35	25/35
	A12C	1	8.4/11.2	28.66/38.21	23.4/27	52/56	60/60	60/60	30/35	22/22	25/35	25/35	25/35	25/35
	A15C	1	10.8/14.4	36.84/49.13	30.1/34.7	60/66	70/70	70/70	40/45	22/22	25/35	25/35	25/35	25/35
A20C	1	14.4/19.2	49.13/65.5	40/46.3	72/80	80/80	90/90	50/58	50/60	22/22	25/35	25/35	25/35	25/35
A060CL	No Heat	—	—	—	—	26/26	30/40	30/40	—	26/26	30/40	30/40	30/40	30/40
	A06C	1	4.2/5.6	14.33/19.1	11.7/13.5	41/43	45/50	45/50	15/20	26/26	30/40	30/40	30/40	30/40
	A10C	1	7.2/9.6	24.56/32.75	20/23.1	51/55	60/60	60/60	25/30	26/26	30/40	30/40	30/40	30/40
	A12C	1	8.4/11.2	28.66/38.21	23.4/27	56/60	60/60	70/70	30/35	26/26	30/40	30/40	30/40	30/40
	A15C	1	10.8/14.4	36.84/49.13	30.1/34.7	64/70	70/70	80/80	40/45	26/26	30/40	30/40	30/40	30/40
A20C	1	14.4/19.2	49.13/65.5	40/46.3	76/84	80/80	90/90	50/58	50/60	26/26	30/40	30/40	30/40	30/40

208-240 VOLT, THREE PHASE, 60 HZ, AUXILIARY ELECTRIC HEATER KITS CHARACTERISTICS AND APPLICATION													
Separate Power Supply for Both Unit and Heater Kit													
Single Power Supply for Both Unit and Heater Kit													
Heater Kit													
Model No. RJPL-	RXJJ- Heater Kit Nominal kW	No. of Sequence Steps	Rated Heater kW @ 208-240V	Heater kBTU/Hr @ 208-240V	Heater Amps @ 208-240V	Unit Min. Cmt. Ampacity @ 208-240V	Over Current Protective Device Size		Heater Kit		Air Conditioner		Over Current Protective Device Size Min./Max. 240V
							Min./Max. 208V	Min./Max. 240V	Min. Cmt. Ampacity 208-240V	Max. Fuse Size 208-240V	Min. Circuit Ampacity 208-240V	Min./Max. 208V	
A036CM	No Heat	—	—	—	—	18/18	25/25	25/25	—	—	18/18	25/25	25/25
	A06C	1	4.2/5.6	14.33/19.1	11.7/13.5	33/35	35/35	40/40	15/20	15/20	18/18	25/25	25/25
	A10C	1	7.2/9.6	24.56/32.75	20/23.1	43/47	45/45	50/50	25/30	25/30	18/18	25/25	25/25
	A12C	1	8.4/11.2	28.66/38.21	23.4/27	48/52	50/50	60/60	30/35	30/35	18/18	25/25	25/25
	A15C	1	10.8/14.4	36.84/49.13	30.1/34.7	56/62	60/60	70/70	40/45	40/45	18/18	25/25	25/25
	A20C	1	14.4/19.2	49.13/65.5	40/46.3	68/76	70/70	80/80	50/60	50/60	18/18	25/25	25/25
A042CM	No Heat	—	—	—	—	22/22	30/35	30/35	—	—	22/22	30/35	30/35
	A06C	1	4.2/5.6	14.33/19.1	11.7/13.5	37/39	40/45	40/45	15/20	15/20	22/22	30/35	30/35
	A10C	1	7.2/9.6	24.56/32.75	20/23.1	47/51	50/50	60/60	25/30	25/30	22/22	30/35	30/35
	A12C	1	8.4/11.2	28.66/38.21	23.4/27	52/56	60/60	60/60	30/35	30/35	22/22	30/35	30/35
	A15C	1	10.8/14.4	36.84/49.13	30.1/34.7	60/66	70/70	70/70	40/45	40/45	22/22	30/35	30/35
	A20C	1	14.4/19.2	49.13/65.5	40/46.3	72/80	80/80	90/90	50/60	50/60	22/22	30/35	30/35
A048CM	No Heat	—	—	—	—	23/23	30/35	30/35	—	—	23/23	30/35	30/35
	A06C	1	4.2/5.6	14.33/19.1	11.7/13.5	38/40	40/45	45/45	15/20	15/20	23/23	30/35	30/35
	A10C	1	7.2/9.6	24.56/32.75	20/23.1	48/52	50/50	60/60	25/30	25/30	23/23	30/35	30/35
	A12C	1	8.4/11.2	28.66/38.21	23.4/27	53/57	60/60	60/60	30/35	30/35	23/23	30/35	30/35
	A15C	1	10.8/14.4	36.84/49.13	30.1/34.7	61/67	70/70	70/70	40/45	40/45	23/23	30/35	30/35
	A20C	1	14.4/19.2	49.13/65.5	40/46.3	73/81	80/80	90/90	50/60	50/60	23/23	30/35	30/35
A060CM	No Heat	—	—	—	—	26/26	30/40	30/40	—	—	26/26	30/40	30/40
	A06C	1	4.2/5.6	14.33/19.1	11.7/13.5	41/43	45/50	45/50	15/20	15/20	26/26	30/40	30/40
	A10C	1	7.2/9.6	24.56/32.75	20/23.1	51/55	60/60	60/60	25/30	25/30	26/26	30/40	30/40
	A12C	1	8.4/11.2	28.66/38.21	23.4/27	56/60	60/60	70/70	30/35	30/35	26/26	30/40	30/40
	A15C	1	10.8/14.4	36.84/49.13	30.1/34.7	64/70	70/70	80/80	40/45	40/45	26/26	30/40	30/40
	A20C	1	14.4/19.2	49.13/65.5	40/46.3	76/84	80/80	90/90	50/60	50/60	26/26	30/40	30/40

480 VOLT, THREE PHASE, 60 HZ., AUXILIARY ELECTRIC HEATER KITS CHARACTERISTICS AND APPLICATION													
Single Power Supply for Both Unit and Heater Kit							Separate Power Supply for Both Unit and Heater Kit						
Model No. RJPL-	RXJJ-Heater Kit Nominal kW	No. of Sequence Steps	Rated Heater kW @ 480V	Heater kBTU/Hr @ 480V	Heater Amps @ 480V	Unit Min. Dkt. Ampacity @ 480V	Air Conditioner		Heater Kit		Air Conditioner		Over Current Protective Device Size Min./Max. 480V
							Min./Max. 480V	Min./Max. 480V	Min. Dkt. Ampacity 480V	Max. Fuse Size 480V	Min. Circuit Ampacity 480V	Min./Max. 480V	
A036DK	No Heat	—	—	—	—	10	15/15	—	—	—	10	15/15	—
	A06D	1	5.6	19.1	6.7	19	20/20	—	—	9	15	15/15	0/0
	A10D	1	9.6	32.75	11.6	25	25/25	—	—	15	15	15/15	0/0
	A12D	1	11.2	38.21	13.5	27	30/30	—	—	17	20	15/15	0/0
	A15D	1	14.4	49.13	17.4	32	35/35	—	—	22	25	15/15	0/0
A20D	1	19.2	65.5	23.3	40	40/40	—	—	30	30	15/15	0/0	
A042DK	No Heat	—	—	—	—	10	15/15	—	—	—	10	15/15	—
	A06D	1	5.6	19.1	6.7	19	20/20	—	—	9	15	15/15	0/0
	A10D	1	9.6	32.75	11.6	25	25/25	—	—	15	15	15/15	0/0
	A12D	1	11.2	38.21	13.5	27	30/30	—	—	17	20	15/15	0/0
	A15D	1	14.4	49.13	17.4	32	35/35	—	—	22	25	15/15	0/0
A20D	1	19.2	65.5	23.3	40	40/40	—	—	30	30	15/15	0/0	
A048DK	No Heat	—	—	—	—	10	15/15	—	—	—	10	15/15	—
	A06D	1	5.6	19.1	6.7	19	20/20	—	—	9	15	15/15	0/0
	A10D	1	9.6	32.75	11.6	25	25/25	—	—	15	15	15/15	0/0
	A12D	1	11.2	38.21	13.5	27	30/30	—	—	17	20	15/15	0/0
	A15D	1	14.4	49.13	17.4	32	35/35	—	—	22	25	15/15	0/0
A20D	1	19.2	65.5	23.3	40	40/40	—	—	30	30	15/15	0/0	
A060DK	No Heat	—	—	—	—	13	15/20	—	—	—	13	15/20	—
	A06D	1	5.6	19.1	6.7	22	25/25	—	—	9	15	15/20	0/0
	A10D	1	9.6	32.75	11.6	28	30/30	—	—	15	15	15/20	0/0
	A12D	1	11.2	38.21	13.5	30	30/30	—	—	17	20	15/20	0/0
	A15D	1	14.4	49.13	17.4	35	35/35	—	—	22	25	15/20	0/0
A20D	1	19.2	65.5	23.3	43	45/45	—	—	30	30	15/20	0/0	

480 VOLT, THREE PHASE, 60 HZ., AUXILIARY ELECTRIC HEATER KITS CHARACTERISTICS AND APPLICATION															
Single Power Supply for Both Unit and Heater Kit						Separate Power Supply for Both Unit and Heater Kit									
Model No. RJPL-	Heater Kit					Air Conditioner					Heater Kit		Air Conditioner		
	RXJJ-Heater Kit Nominal kW	No. of Sequence Steps	Rated Heater kW @ 480V	Heater kBTU/Hr @ 480V	Heater Amps @ 480V	Unit Min. Dlt. Ampacity @ 480V	Over Current Protective Device Size Min./Max. 480V	Min. Dlt. Ampacity 480V	Max. Fuse Size 480V	Min. Circuit Ampacity 480V	Over Current Protective Device Size Min./Max. 480V	Min. Dlt. Ampacity 480V	Max. Fuse Size 480V	Min. Circuit Ampacity 480V	Over Current Protective Device Size Min./Max. 480V
A036DL	No Heat	—	—	—	—	10	15/15	—	—	10	15/15	—	—	10	15/15
	A06D	1	5.6	19.1	6.7	19	20/20	9	15	10/0	15/15	15	10/0	15/15	
	A10D	1	9.6	32.75	11.6	25	25/25	15	15	10/0	15/15	15	10/0	15/15	
	A12D	1	11.2	38.21	13.5	27	30/30	17	20	10/0	15/15	20	10/0	15/15	
	A15D	1	14.4	49.13	17.4	32	35/35	22	25	10/0	15/15	25	10/0	15/15	
A042DL	A20D	1	19.2	65.5	23.3	40	40/40	30	30	10/0	15/15	30	10/0	15/15	
	No Heat	—	—	—	—	10	15/15	—	—	10	15/15	—	—	10	15/15
	A06D	1	5.6	19.1	6.7	19	20/20	9	15	10/0	15/15	15	10/0	15/15	
	A10D	1	9.6	32.75	11.6	25	25/25	15	15	10/0	15/15	15	10/0	15/15	
	A12D	1	11.2	38.21	13.5	27	30/30	17	20	10/0	15/15	20	10/0	15/15	
A048DL	A15D	1	14.4	49.13	17.4	32	35/35	22	25	10/0	15/15	25	10/0	15/15	
	A20D	1	19.2	65.5	23.3	40	40/40	30	30	10/0	15/15	30	10/0	15/15	
	No Heat	—	—	—	—	11	15/15	—	—	11	15/15	—	—	11	15/15
	A06D	1	5.6	19.1	6.7	20	20/20	9	15	11/0	15/15	15	11/0	15/15	
	A10D	1	9.6	32.75	11.6	26	30/30	15	15	11/0	15/15	15	11/0	15/15	
A060DL	A12D	1	11.2	38.21	13.5	28	30/30	17	20	11/0	15/15	20	11/0	15/15	
	A15D	1	14.4	49.13	17.4	33	35/35	22	25	11/0	15/15	25	11/0	15/15	
	A20D	1	19.2	65.5	23.3	41	40/40	30	30	11/0	15/15	30	11/0	15/15	
	No Heat	—	—	—	—	13	15/20	—	—	13	15/20	—	—	13	15/20
	A06D	1	5.6	19.1	6.7	22	25/25	9	15	13/0	15/20	15	13/0	15/20	
A060DL	A10D	1	9.6	32.75	11.6	28	30/30	15	15	13/0	15/20	15	13/0	15/20	
	A12D	1	11.2	38.21	13.5	30	30/30	17	20	13/0	15/20	20	13/0	15/20	
	A15D	1	14.4	49.13	17.4	35	35/35	22	25	13/0	15/20	25	13/0	15/20	
	A20D	1	19.2	65.5	23.3	43	45/45	30	30	13/0	15/20	30	13/0	15/20	

480 VOLT, THREE PHASE, 60 HZ, AUXILIARY ELECTRIC HEATER KITS CHARACTERISTICS AND APPLICATION												
Single Power Supply for Both Unit and Heater Kit						Separate Power Supply for Both Unit and Heater Kit						
Model No. RJPL-	Heater Kit			Air Conditioner			Heater Kit			Air Conditioner		
	RXJJ-Heater Kit Nominal kW	No. of Sequence Steps	Rated Heater kW @ 480V	Heater kBTU/Hr @ 480V	Heater Amps @ 480V	Unit Min. Dmt. Ampacity @ 480V	Over Current Protective Device Size Min./Max. 480V	Min. Dmt. Ampacity 480V	Max. Fuse Size 480V	Min. Circuit Ampacity 480V	Over Current Protective Device Size Min./Max. 480V	
A036DM	No Heat	—	—	—	—	10	15/15	—	—	10	15/15	—
	A06D	1	5.6	19.1	6.7	19	20/20	9	15	10/0	15/15	0/0
	A10D	1	9.6	32.75	11.6	25	25/25	15	15	10/0	15/15	0/0
	A12D	1	11.2	38.21	13.5	27	30/30	17	20	10/0	15/15	0/0
	A15D	1	14.4	49.13	17.4	32	35/35	22	25	10/0	15/15	0/0
A20D	1	19.2	65.5	23.3	40	40/40	—	30	10/0	15/15	0/0	
A042DM	No Heat	—	—	—	—	11	15/15	—	—	11	15/15	—
	A06D	1	5.6	19.1	6.7	20	20/20	9	15	11/0	15/15	0/0
	A10D	1	9.6	32.75	11.6	26	30/30	15	15	11/0	15/15	0/0
	A12D	1	11.2	38.21	13.5	28	30/30	17	20	11/0	15/15	0/0
	A15D	1	14.4	49.13	17.4	33	35/35	22	25	11/0	15/15	0/0
A20D	1	19.2	65.5	23.3	41	40/40	—	30	11/0	15/15	0/0	
A048DM	No Heat	—	—	—	—	11	15/15	—	—	11	15/15	—
	A06D	1	5.6	19.1	6.7	20	20/20	9	15	11/0	15/15	0/0
	A10D	1	9.6	32.75	11.6	26	30/30	15	15	11/0	15/15	0/0
	A12D	1	11.2	38.21	13.5	28	30/30	17	20	11/0	15/15	0/0
	A15D	1	14.4	49.13	17.4	33	35/35	22	25	11/0	15/15	0/0
A20D	1	19.2	65.5	23.3	41	45/45	—	30	11/0	15/15	0/0	
A060DM	No Heat	—	—	—	—	13	15/20	—	—	13	15/20	—
	A06D	1	5.6	19.1	6.7	22	25/25	9	15	13/0	15/20	0/0
	A10D	1	9.6	32.75	11.6	28	30/30	15	15	13/0	15/20	0/0
	A12D	1	11.2	38.21	13.5	30	35/35	17	20	13/0	15/20	0/0
	A15D	1	14.4	49.13	17.4	35	40/40	22	25	13/0	15/20	0/0
A20D	1	19.2	65.5	23.3	43	45/45	—	30	13/0	15/20	0/0	

208-240 VOLT, THREE PHASE, 60 HZ., AUXILIARY ELECTRIC HEATER KITS CHARACTERISTICS AND APPLICATION															
Separate Power Supply for Both Unit and Heater Kit															
Single Power Supply for Both Unit and Heater Kit							Heater Kit								
Model No. RJPL-	RXJJ- Heater Kit Nominal kW	No. of Sequence Steps	Rated Heater kW @ 208-240V	Heater kBTU/Hr @ 208-240V	Heater Amps @ 208-240V	Unit Min. Jkt. Ampacity @ 208-240V	Air Conditioner			Heater Kit			Air Conditioner		
							Over Current Protective Device Size Min./Max. 208V	Over Current Protective Device Size Min./Max. 240V	Unit Min. Jkt. Ampacity @ 208-240V	Max. Fuse Size 208-240V	Min. Jkt. Ampacity 208-240V	Min. Circuit Ampacity 208-240V	Over Current Protective Device Size Min./Max. 208V	Over Current Protective Device Size Min./Max. 240V	
A036JK	No Heat	—	—	—	—	24/24	30/40	30/40	30/40	—	—	24/24	30/40	30/40	
	A06J	1	4.2/5.6	14.33/19.1	20.2/23.3	50/54	50/60	60/60	60/60	26/30	30/30	24/24	30/40	30/40	
	A10J	1	7.2/9.6	24.56/32.75	34.6/40	68/74	70/70	80/80	80/80	44/50	45/50	24/24	30/40	30/40	
	A12J	1	8.4/11.2	28.66/38.21	40.4/46.7	75/83	80/80	90/90	90/90	51/59	60/60	24/24	30/40	30/40	
	A15J	1	10.8/14.4	36.84/49.13	51.9/60	89/99	90/90	100/100	100/100	65/75	70/80	24/24	30/40	30/40	
A042JK	A20J	1	14.4/19.2	49.13/65.5	69.3/80	111/124	125/125	125/125	125/125	87/100	90/100	24/24	30/40	30/40	
	No Heat	—	—	—	—	26/26	35/40	35/40	35/40	—	—	26/26	35/40	35/40	
	A06J	1	4.2/5.6	14.33/19.1	20.2/23.3	52/56	60/60	60/60	60/60	26/30	30/30	26/26	35/40	35/40	
	A10J	1	7.2/9.6	24.56/32.75	34.6/40	70/76	70/70	80/80	80/80	44/50	45/50	26/26	35/40	35/40	
	A12J	1	8.4/11.2	28.66/38.21	40.4/46.7	77/85	80/80	90/90	90/90	51/59	60/60	26/26	35/40	35/40	
A048JK	A15J	1	10.8/14.4	36.84/49.13	51.9/60	91/101	100/100	100/100	110/110	65/75	70/80	26/26	35/40	35/40	
	A20J	1	14.4/19.2	49.13/65.5	69.3/80	113/126	125/125	150/150	150/150	87/100	90/100	26/26	35/40	35/40	
	No Heat	—	—	—	—	31/31	40/50	40/50	40/50	—	—	31/31	40/50	40/50	
	A06J	1	4.2/5.6	14.33/19.1	20.2/23.3	57/61	60/70	70/70	70/70	26/30	30/30	31/31	40/50	40/50	
	A10J	1	7.2/9.6	24.56/32.75	34.6/40	75/81	80/80	90/90	90/90	44/50	45/50	31/31	40/50	40/50	
A060JK	A12J	1	8.4/11.2	28.66/38.21	40.4/46.7	82/90	90/90	90/90	90/90	51/59	60/60	31/31	40/50	40/50	
	A15J	1	10.8/14.4	36.84/49.13	51.9/60	96/106	100/100	110/110	110/110	65/75	70/80	31/31	40/50	40/50	
	A20J	1	14.4/19.2	49.13/65.5	69.3/80	118/131	125/125	150/150	150/150	87/100	90/100	31/31	40/50	40/50	
	No Heat	—	—	—	—	39/39	45/60	45/60	45/60	—	—	39/39	45/60	45/60	
	A06J	1	4.2/5.6	14.33/19.1	20.2/23.3	65/69	70/80	70/80	70/80	26/30	30/30	39/39	45/60	45/60	
A060JK	A10J	1	7.2/9.6	24.56/32.75	34.6/40	83/89	90/90	90/90	90/100	44/50	45/50	39/39	45/60	45/60	
	A12J	1	8.4/11.2	28.66/38.21	40.4/46.7	90/98	90/100	100/110	100/110	51/59	60/60	39/39	45/60	45/60	
	A15J	1	10.8/14.4	36.84/49.13	51.9/60	104/114	110/110	125/125	125/125	65/75	70/80	39/39	45/60	45/60	
	A20J	1	14.4/19.2	49.13/65.5	69.3/80	126/139	150/150	150/150	150/150	87/100	90/100	39/39	45/60	45/60	

UNIT DIMENSIONS PACKAGE HEAT PUMPS 3-5 TON [10.6-17.6 kW]

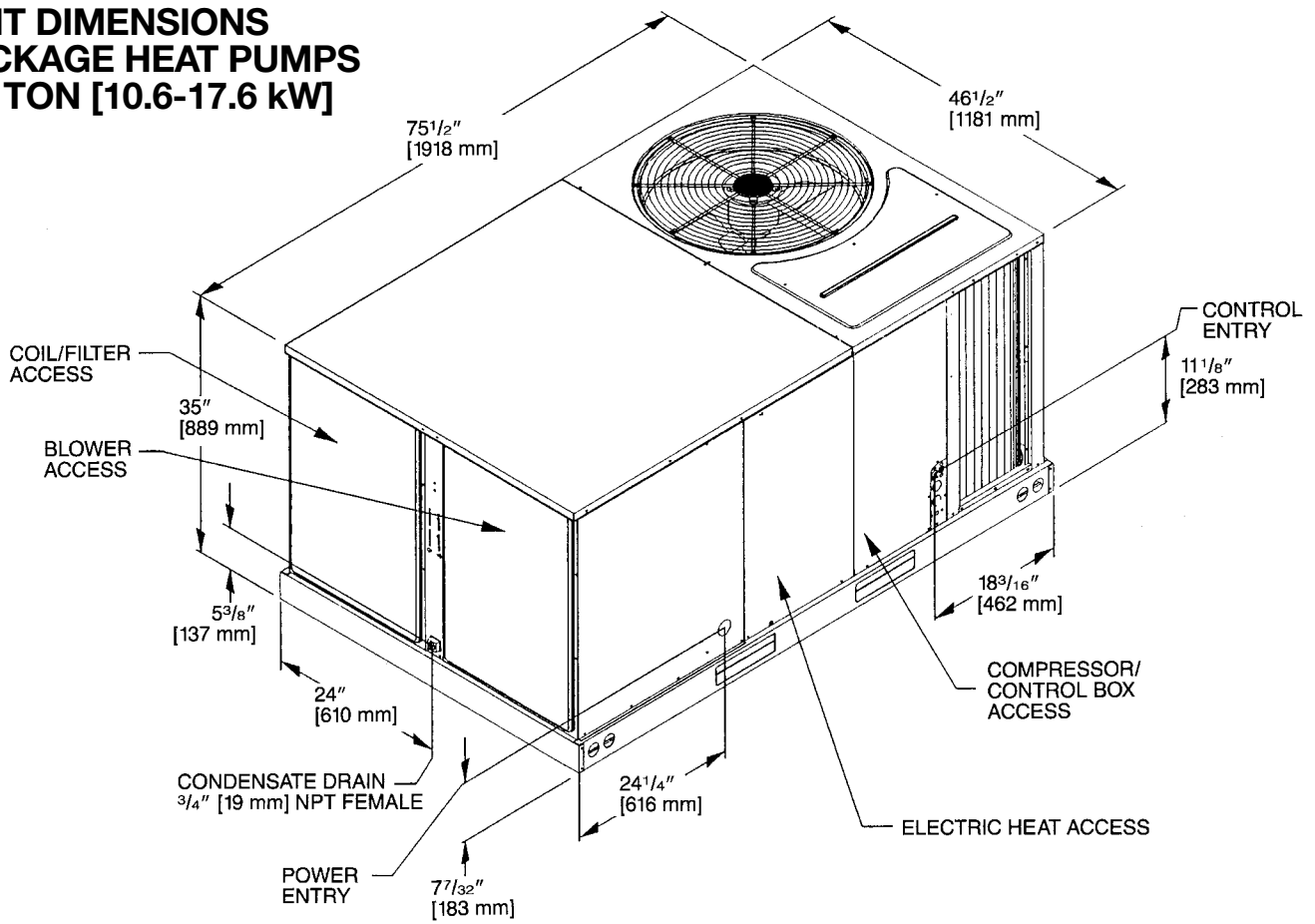

SUPPLY AND RETURN DIMENSIONS

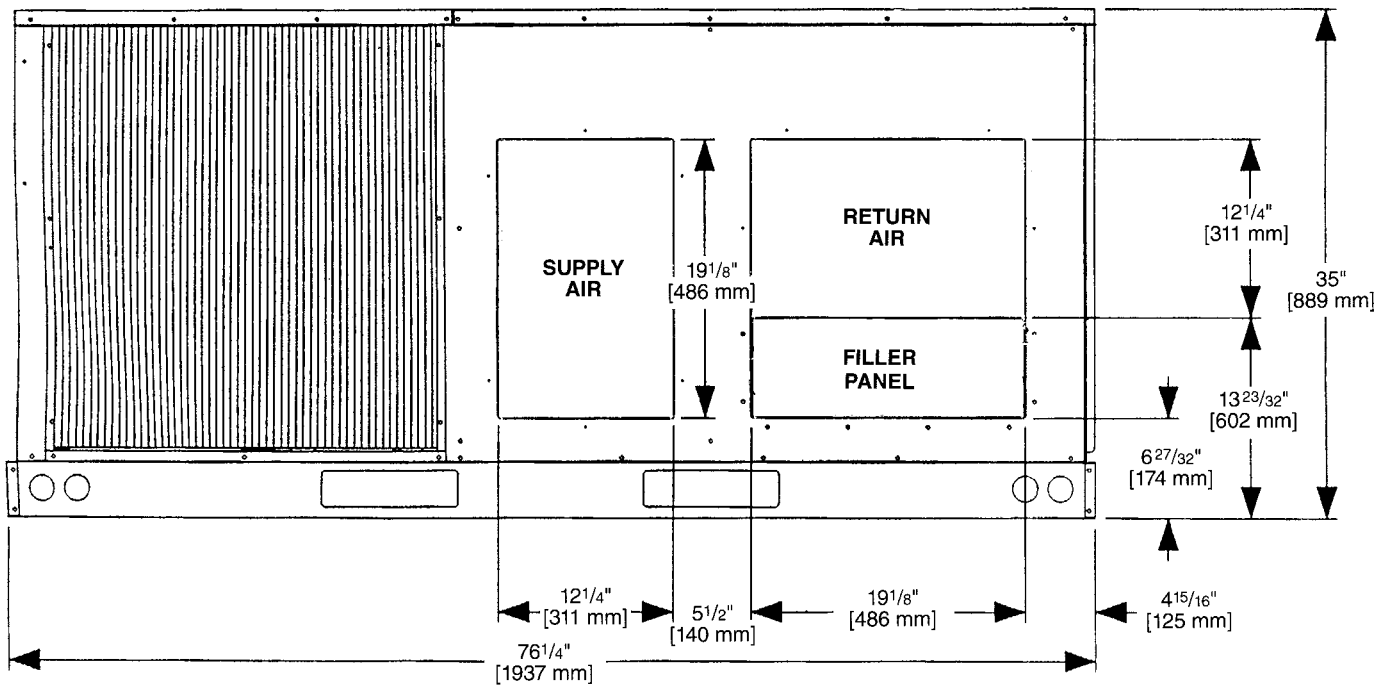

[] Designates Metric Conversions

UNIT DIMENSIONS PACKAGE HEAT PUMPS 3-5 TON [10.6-17.6 kW]

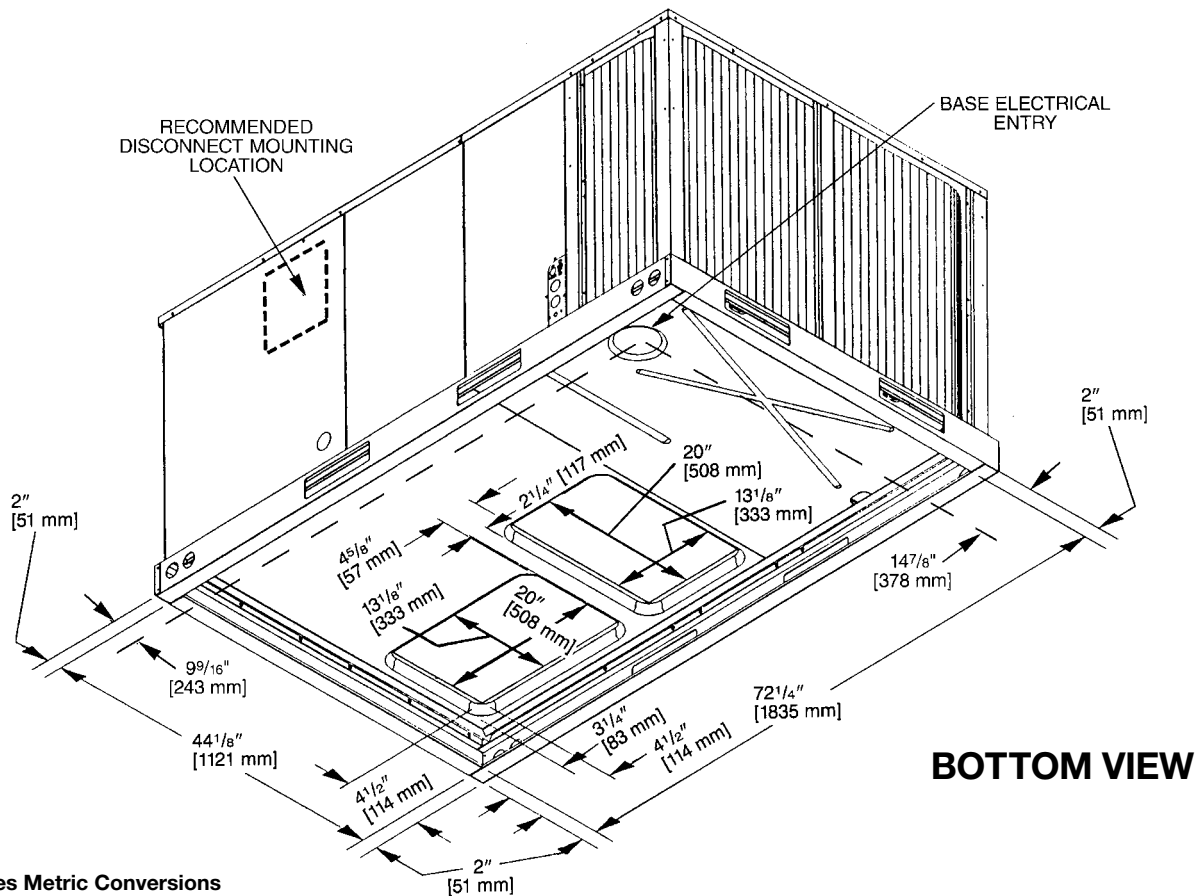
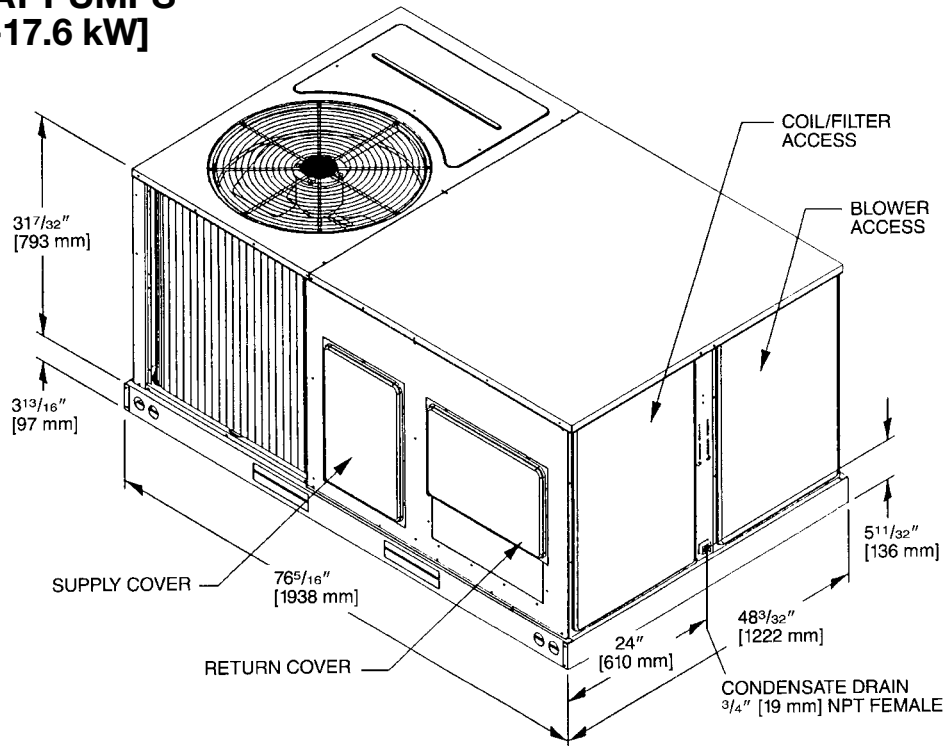

BOTTOM VIEW

[] Designates Metric Conversions

WEIGHTS

Accessory	3-5 Ton [10.6-17.6 kW]	
	Shipping	Operating
	lbs [kg]	lbs [kg]
Economizer with Single Enthalpy	70 [32]	60 [27]
Power Exhaust	19 [9]	16 [7]
Fresh Air Damper (Manual)	11 [5]	9 [4]
Fresh Air Damper (Motorized)	13 [6]	11 [5]
Roof Curb 14"	92 [42]	88 [40]
Roof Curb 24"	108 [49]	104 [47]
Concentric Diffuser 18" Flush	37 [17]	26 [12]
Concentric Diffuser 20" Flush	54 [24]	42 [19]
Side Discharge Concentric Diffuser RXRN-FA60	35 [16]	20 [9]
Side Discharge Concentric Diffuser RXRN-FA65	55 [25]	40 [18]

CLEARANCES

(3 to 5 Ton [10.6 to 17.6 kW] Models)

The following minimum clearances are recommended for proper unit performance and serviceability.

Recommended Clearance in. [mm]	Location
48 [1219]	A - Front
18 [457]	B - Condenser Coil
*12 [305]	C - Duct Side
36 [914]	D - Evaporator End
60 [1524]	E - Above
*57" [1448 mm] With Economizer	

NOTE: Supply duct may be installed with "0" inch clearance to combustible materials, provided 1" [25.4 mm] minimum. Fiberglass insulation is applied either inside or on the outside of the duct.

CENTER OF GRAVITY (C.G.)

Capacity Tons [kW]	A in. [mm]	B in. [mm]
3-5 [10.6-17.6]	38 ¹ / ₄ [972]	25 ³ / ₄ [654]

Capacity Tons [kW]	Corner Weights by Percentage			
	A	B	C	D
3-5 [10.6-17.6]	22%	27%	23%	28%

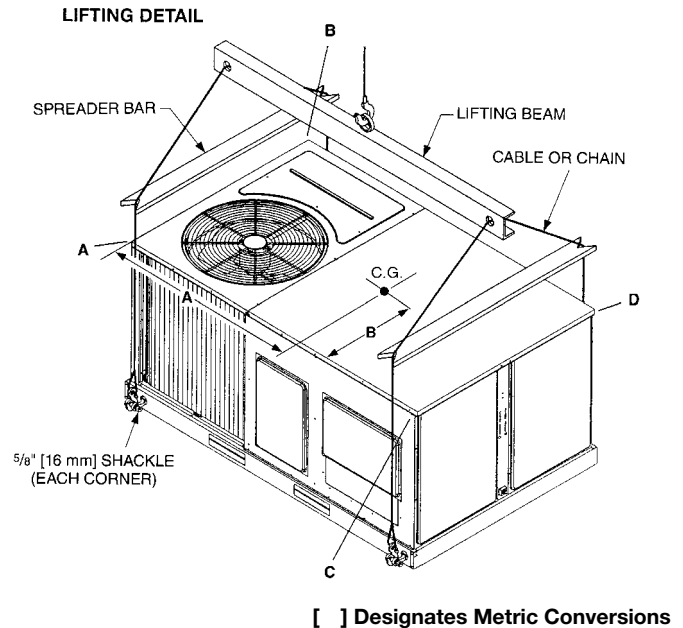
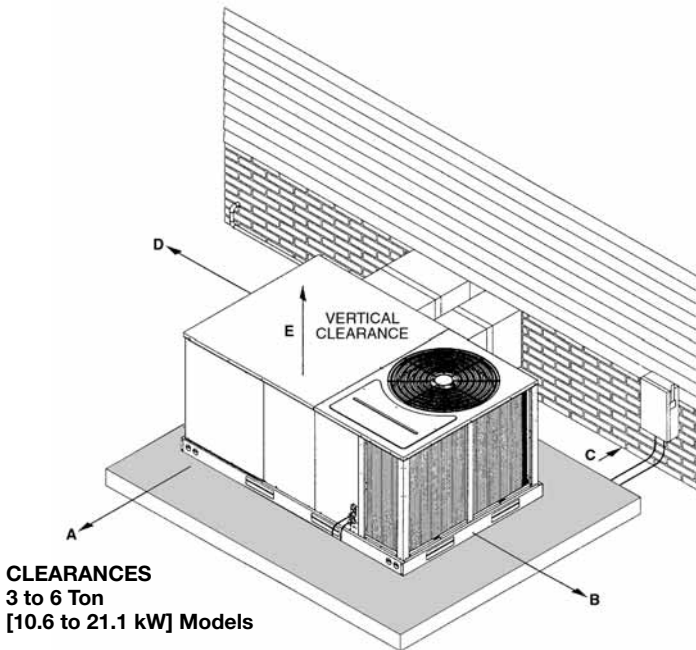

ACCESSORY EQUIPMENT

Description	Model Number	Factory Installed
	3-5 Ton [10.6-17.6 kW] (RJNL/RJPL)	
Electric Heater Kits	RXJJ-A06* (J,C,D)	See Heater Kit Electric Table
	RXJJ-A10* (J,C,D)	
	RXJJ-A11* (J,C,D)	
	RXJJ-A12* (J,C,D)	
	RXJJ-A15* (J,C,D)	
	RXJJ-A20* (J,C,D)	
	RXJJ-A21* (J,C,D)	
	RXJJ-A24* (J,C,D)	
Roofcurb 14"	RXKG-CAD14	No
Roofcurb 24"	RXKG-CAD24	No
Roofcurb Adaptors	RXXR-BBCDB21	No
	RXXR-BBCDB22	
	RXXR-BBCDB23	
Economizer with Single Enthalpy	AXRD-MECM3	Yes
Dual Enthalpy Kit	RXXR-AV02	No
CO2 Sensor	RXXR-AR02	No
Power Exhaust	AXRX-BGF04* (C or D) (use C for J voltage)	No
Fresh Air Damper Manual	AXRF-FBA1	No
Fresh Air Damper Motorized	AXRF-FBB1	No
Rectangular to Round 18" Duct Adaptors for Concentric Diffuser	RXMC-CB03	No
Rectangular to Round 20" Duct Adaptors for Concentric Diffuser	RXMC-CB04	No
Concentric Diffuser 18" Step (Side discharge)	RXRN-FA60	No
Concentric Diffuser 20" Step (Side discharge)	RXRN-FA65	No
Concentric Diffuser 18" Flush	RXRN-FA70	No
Concentric Diffuser 20" Flush	RXRN-FA75	No
Rectangular to Round 16" Side	RXMC-BB01	No
Louver Kit (3 Sides)	AXRX-AAD01B	Yes
Time Delay	RXMS-B01	Yes
Low Ambient Control to 0°F [-18°C]	RXPZ-G01	Yes
Freeze Stat	RXXR-AM04	Yes

*Voltage

J = 208-230 VAC-1PH-60HZ D = 460 VAC-3PH-60HZ
 C = 208-230 VAC-3PH-60HZ Y = 575 VAC-3PH-60HZ

NOTES: ① Economizer is designed for downflow or horizontal applications.

[] Designates Metric Conversions

Roofcurb Adapters

Old Models

MEDIUM CABINET (3 TON [11 kW])

(-)SNC, (-)SND, (-)SNE
(-)RGE, (-)RGF, (-)RGG
(-)PNC, (-)PND

LARGE CABINET

(3-3.5 TON [11-12 kW])
(-)RGE, (-)RGF, (-)RGG,
(-)RGH (3 TON [11 kW])

EXTRA LARGE CABINET

(3.5-5 TON [12-18 kW])
(-)SNC, (-)SND, (-)SNE
(-)RGE, (-)RGF,
(-)RGG (4-5 TON [14-18 kW])
(-)PNC, (-)PND, (-)RGH
(3.5, 4 TON [12-14 kW])

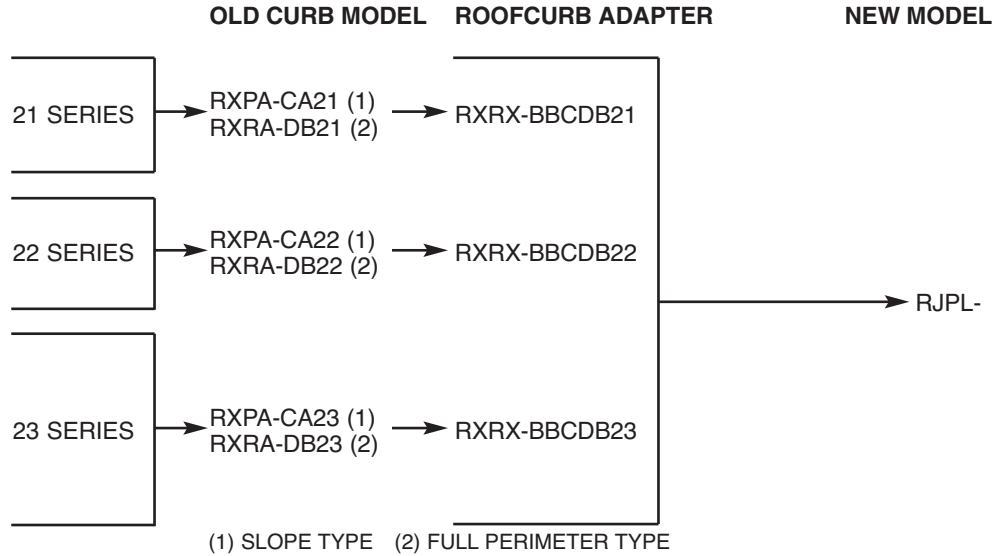

Field Installed Resistance Heater Kits

Electric Heater Kits are designed for field installation using either single-point power wiring or dual circuit wiring. Low voltage plugs are provided to allow for quick connection to the unit. Removing a block-off panel on the unit allows the heater elements to be inserted into the supply air down stream from the indoor coil and supply air blower.

[] Designates Metric Conversions

Model Number Identifier:

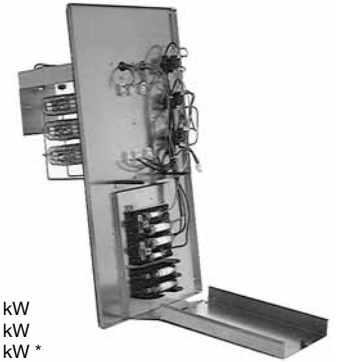
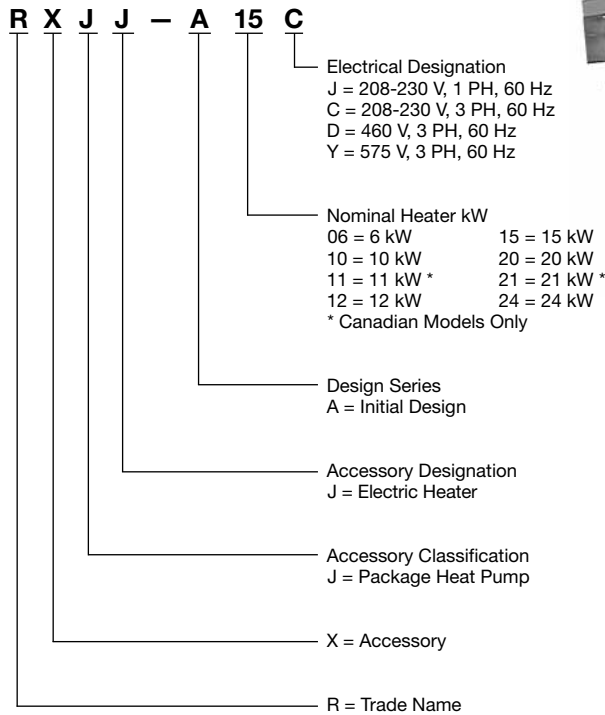

ROOFCURBS (Full Perimeter)

- Rheem's new roofcurb design can be utilized on 3 through 6 ton [10.6-21.1 kW] models.
- Two available heights (14" [356 mm] and 24" [610 mm]) for ALL models.
- Quick assembly corners for simple and fast assembly
- Opening provided in bottom pan to match the "Thru the Curb" electrical connection opening provided on the unit base pan.
- 2" [51 mm] x 4" [102 mm] Nailer provided.
- Insulating panels provided.
- Sealing gasket (28" [711 mm]) provided with Roofcurb.
- Packaged for easy field assembly.

Roofcurb Model	Height of Curb
RXKG-CAD14	14" [356 mm]
RXKG-CAD24	24" [610 mm]

[] Designates Metric Conversions

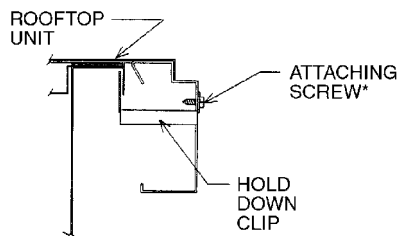
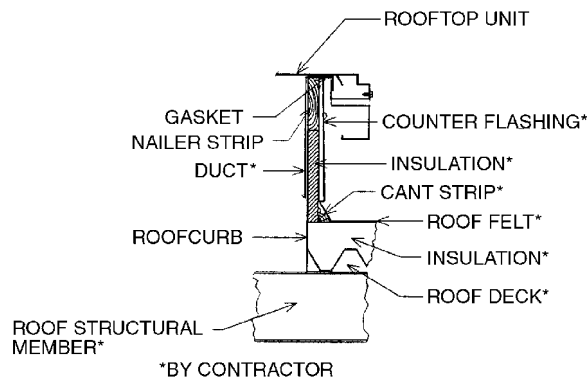

TYPICAL INSTALLATION

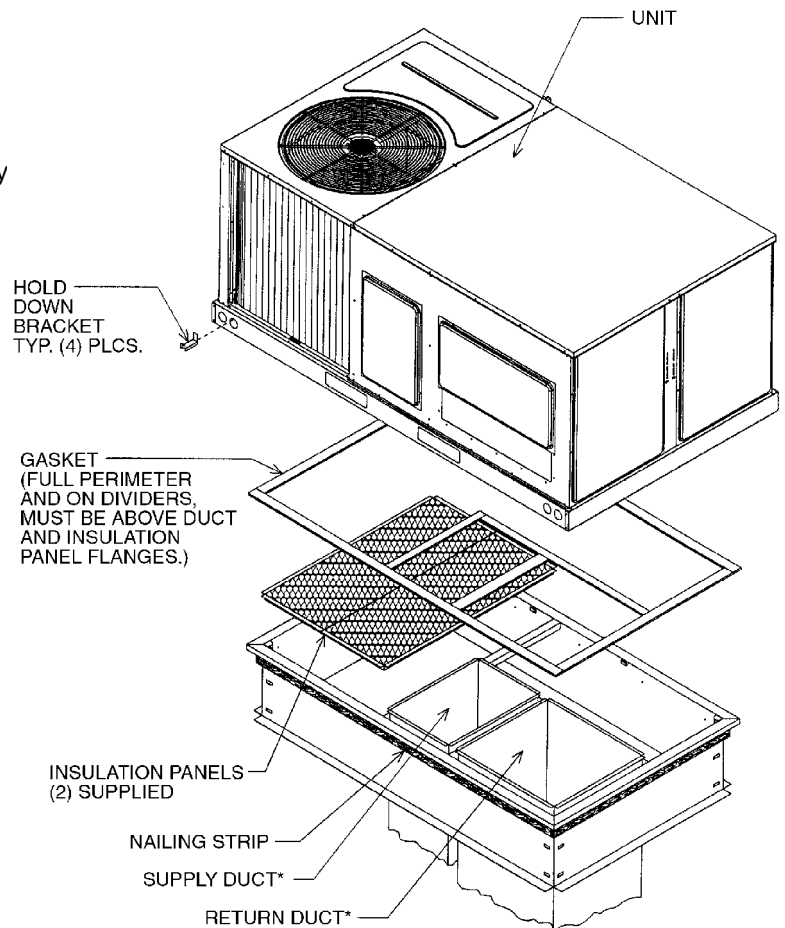

ROOFCURBS (Cont.)

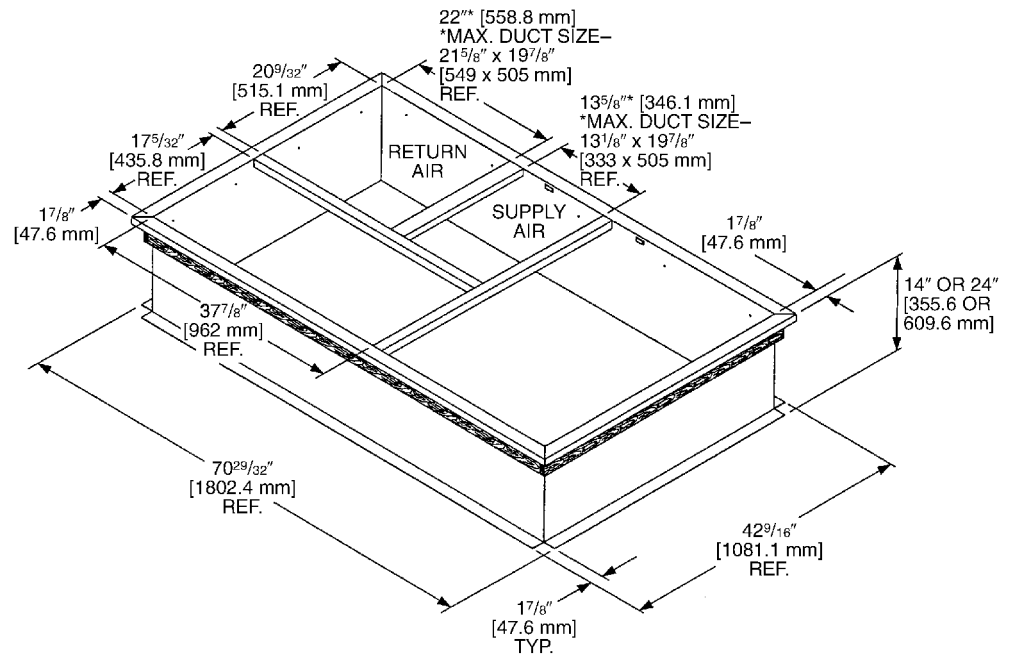

ROOFCURB CONFIGURATION FOR RJPL 3-5 TON [10.6-17.6 kW] MODELS

[] Designates Metric Conversions

Note: Roofcurb kits are the same for all models. (Figures above show locations for cross members that are model specific)

ECONOMIZERS

AXRD-MECM3—3-5 Ton [10.6-17.6 kW] Models Single Enthalpy with Barometric Relief

**RXXR-AV02—Dual Enthalpy Kit
3-5 Ton [10.6-17.6 kW] Models
Optional CO₂ Sensor**

RXXR-AR02—3-5 Ton [10.6-17.6 kW] Models

- Features **Honeywell** Controls
- Available factory installed or field accessory
- Gear Driven Direct Drive Actuator
- Fully Modulating (0-100%)
- Low Leakage Dampers
- Horizontal or Downflow Applications
- Slip-In Design for Easy Installations
- Plug-In Polarized 12-pin Electrical Connections
- Pre-configured—No Field Adjustments Necessary
- Standard Barometric Relief Damper Provided
- Single Enthalpy with Dual Enthalpy Upgrade Kit
- CO₂ Input Sensor Available (Field Installed)
- Economizer slips in complete for Downflow or Horizontal Duct application
- Field Assembled Hood Ships with Economizer
- Optional Remote Minimum Position (Honeywell #S963B1128) is Available from ProStock
- Field Installed Power Exhaust Available

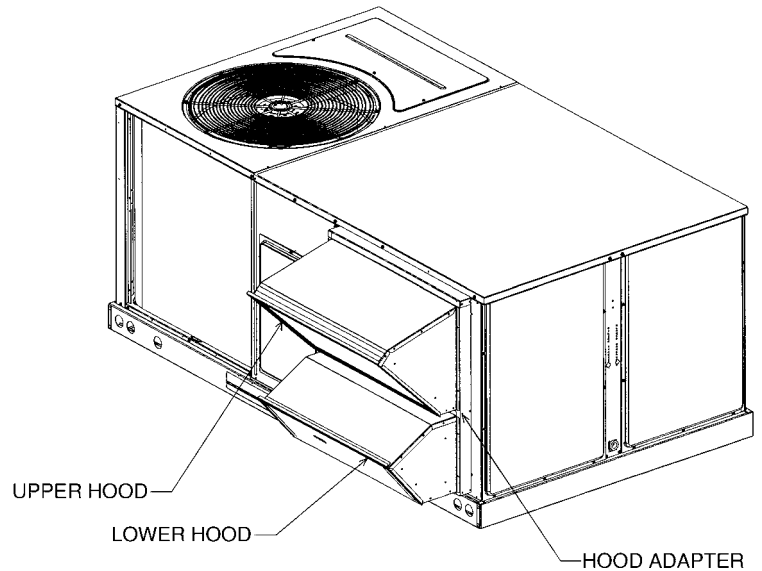

[] Designates Metric Conversions

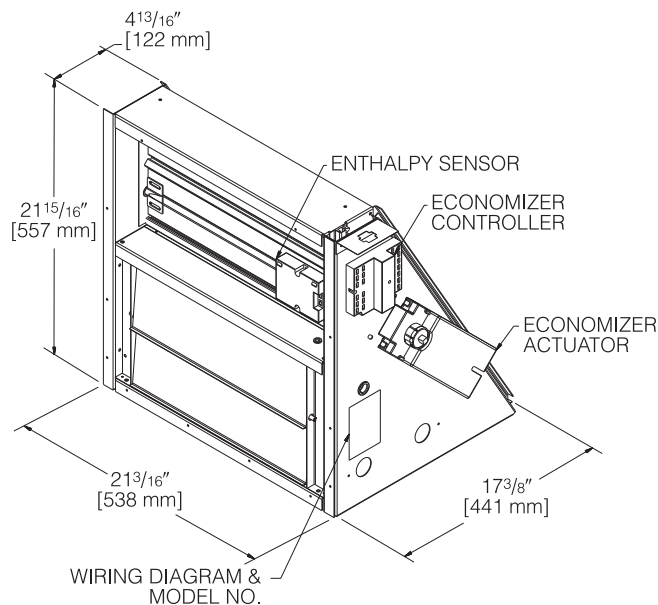

RJPL 3-5 Ton [10.6-17.6 kW] Models

INTEGRAL POWER EXHAUST FOR ECONOMIZER (FIELD INSTALLED ONLY)

**AXRX-BGF04C – 3-5 Ton [10.6-17.6 kW] Models
208-230V, 1 PH and 3 PH, 60 Hz**

**AXRX-BGF04D – 3-5 Ton [10.6-17.6 kW] Models
460V, 3 PH, 60 Hz**

**AXRX-BGF04Y – 3-5 Ton [10.6-17.6 kW] Models
575V, 3 PH, 60 Hz**

- For **Honeywell** Economizer
- Downflow or horizontal applications
- Requires separate 208-230 Volt – 1 PH power supply with disconnect or requires separate 460V – 3 PH power supply with disconnect
- Adjustable switch on economizer, factory preset to energize power exhaust at 95% outside air position
- Polarized plug connects power exhaust relay to economizer

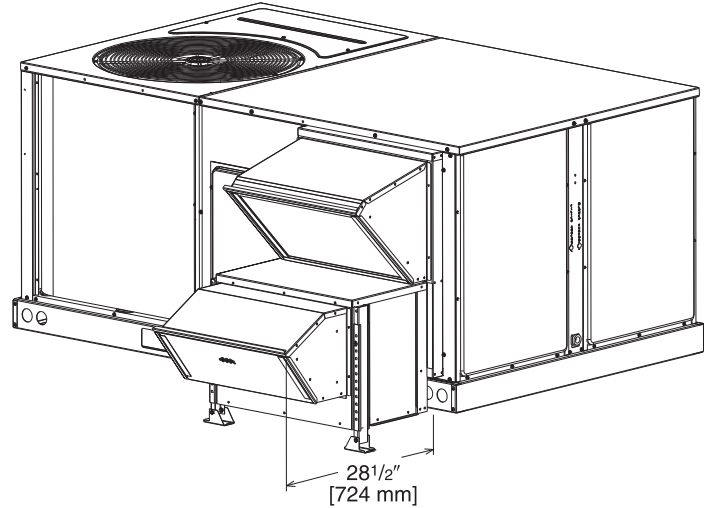

POWER EXHAUST KIT FOR AXRD-01REC(-) ECONOMIZERS

Model No.	No. of Fans	Volts	Phase	Watts (ea.)	High Speed		FLA (ea.)	LRA (ea.)
					CFM ①	RPM		
AXRX-BGF04C	1	208/230	1	1000	2500	1725	4.4	23.7
AXRX-BGF04D	1	460	1	800	2370	1620	1.8	4.1
AXRX-BGF04Y	1	575	1	800	2370	1620	1.5	3.3

AXRX-BGF04C – 3-5 Ton [10.6-17.6 kW] Models

208/230V, 1PH and 3PH, 60 Hz

AXRX-BGF04D – 3-5 Ton [10.6-17.6 kW] Models

460V, 3PH, 60 Hz

AXRX-BGF04Y – 3-5 Ton [10.6-17.6 kW] Models

575V, 3PH, 60 Hz

FRESH AIR DAMPER

3-5 Ton [10.6-17.6 kW] Models

AXRF-FBA1 (Manual)

AXRF-FBB1 (Motorized)

[] Designates Metric Conversions

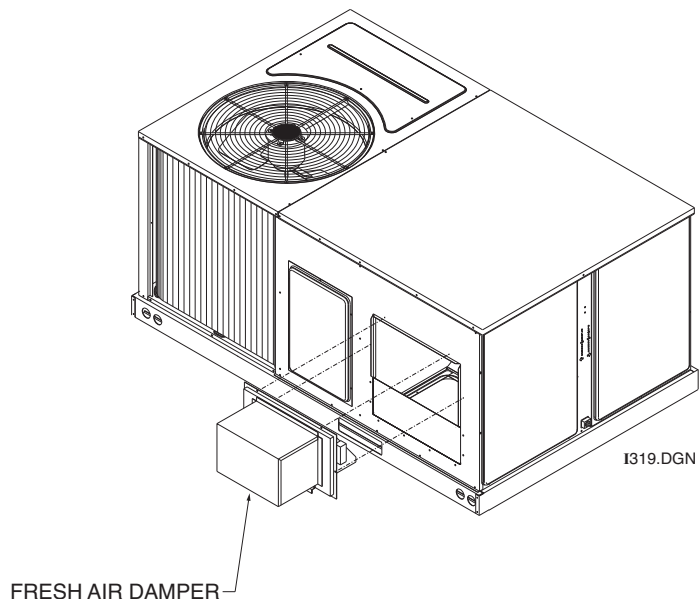

DUCT ADAPTERS (3 TO 5 TON [10.6 TO 17.6 kW] MODELS) Rectangular to Round Transitions (Downflow) RXMC-CB03 – 18" [457 mm] Round

Available in 18 inch round to fit all units. Drops into and secures to RXKG- Series Roofcurbs.
For use with Concentric Diffusers.

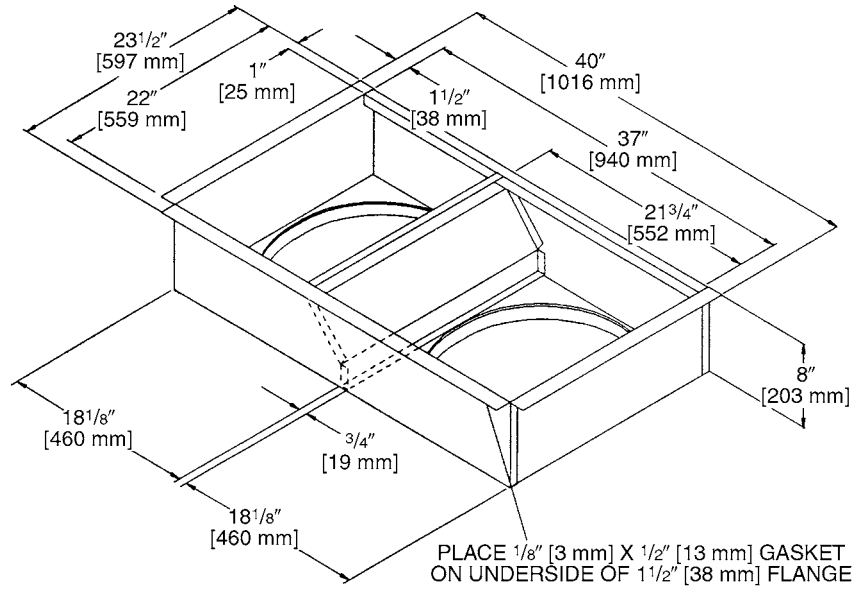

[] Designates Metric Conversions

SIDE DISCHARGE CONCENTRIC DIFFUSER

RXRN-FA60 (3 to 5 Ton [10.6 to 17.6 kW] Models)

For Use With Duct Adapter (RXMC)

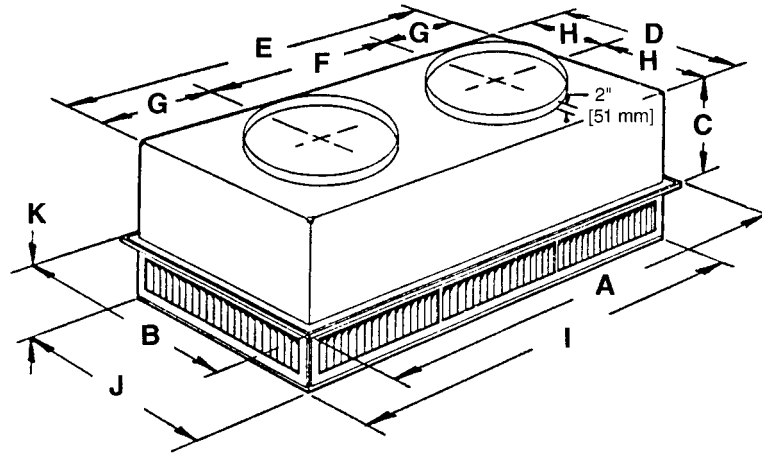

DIMENSIONAL DATA

Model No.	A	B	C	D	E	F	G	H	I	J	K	Duct Size
RXRN-FA60	47 ⁵ / ₈ " [1210 mm]	23 ⁵ / ₈ " [600 mm]	11 ³ / ₈ " [289 mm]	21 ¹ / ₂ " [546 mm]	45 ¹ / ₂ " [1156 mm]	22 ¹ / ₂ " [572 mm]	11 ¹ / ₂ " [292 mm]	10 ³ / ₄ " [273 mm]	45 ¹ / ₂ " [1156 mm]	21 ¹ / ₂ " [546 mm]	7 ¹ / ₈ " [181 mm]	18RD
RXRN-FA65	47 ⁵ / ₈ " [1210 mm]	29 ⁵ / ₈ " [752 mm]	14 ³ / ₈ " [365 mm]	27 ¹ / ₂ " [699 mm]	45 ¹ / ₂ " [1156 mm]	22 ¹ / ₂ " [572 mm]	11 ¹ / ₂ " [292 mm]	13 ³ / ₄ " [349 mm]	45 ¹ / ₂ " [1156 mm]	27 ¹ / ₂ " [699 mm]	8 ¹ / ₈ " [206 mm]	20RD

ENGINEERING DATA

Model No.	CFM [L/s]	Static Pressure	Throw Feet	Neck Vel.	Jet Vel.	Noise Level
RXRN-FA60	1000 [472]	.14	10-17	351	351	20
	1200 [566]	.17	11-18	421	421	20
	1400 [661]	.20	12-19	491	491	20
	1600 [755]	.24	12-20	561	561	20
	1800 [850]	.30	13-21	632	632	20
	2000 [944]	.36	14-23	702	702	20
RXRN-FA65	2200 [1038]	.40	16-25	772	772	20
	2600 [1227]	.17	24-29	669	669	20
	2800 [1321]	.20	25-30	720	720	25
	3000 [1416]	.25	27-33	772	772	25
	3200 [1510]	.31	28-35	823	823	25
3400 [1605]	.37	30-37	874	874	30	

[] Designates Metric Conversions

FLUSH MOUNT CONCENTRIC DIFFUSER

RXRN-FA70 (3 to 5 Ton [10.6 to 17.6 kW] Models)

For Use With Duct Adapter (RXMC)

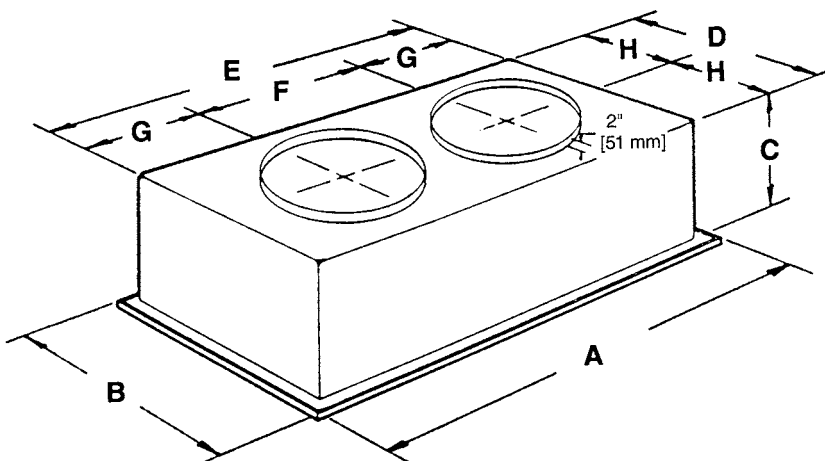

DIMENSIONAL DATA

Model No.	A	B	C	D	E	F	G	H	Duct Size
RXRN-FA70	47 ⁵ / ₈ " [1210 mm]	23 ⁵ / ₈ " [600 mm]	13 ¹ / ₂ " [343 mm]	21" [533 mm]	45" [1143 mm]	22 ¹ / ₂ " [572 mm]	11 ¹ / ₄ " [286 mm]	10 ¹ / ₂ " [267 mm]	18RD
RXRN-FA75	47 ⁵ / ₈ " [1210 mm]	29 ⁵ / ₈ " [752 mm]	16 ⁵ / ₈ " [422 mm]	27" [686 mm]	45" [1143 mm]	22 ¹ / ₂ " [572 mm]	11 ¹ / ₄ " [286 mm]	13 ¹ / ₂ " [343 mm]	20RD

ENGINEERING DATA

Model No.	CFM [L/s]	Static Pressure	Throw Feet	Neck Vel.	Jet Vel.	Noise Level
RXRN-FA70	1000 [472]	.14	15-20	391	694	20
	1200 [566]	.17	16-22	469	833	25
	1400 [661]	.20	17-24	547	972	30
	1600 [755]	.24	18-25	625	1111	30
	1800 [850]	.30	20-28	703	1250	35
	2000 [944]	.36	21-29	781	1389	40
	2200 [1038]	.40	22-30	859	1528	40
RXRN-FA75	2600 [1227]	.17	19-24	663	1294	30
	2800 [1321]	.20	20-28	714	1393	35
	3000 [1416]	.25	21-29	765	1492	35
	3200 [1510]	.31	22-29	816	1592	40
	3400 [1605]	.37	22-30	867	1692	40

[] Designates Metric Conversions

Guide Specifications – RJPL-A036 thru A060

You may copy this document directly into your building specification. This specification is written to comply with the 2004 version of the “master format” as published by the Construction Specification Institute. www.csinet.org.

ROOFTOP PACKAGED HEAT PUMP

HVAC Guide Specifications

Size Range: 3.0 to 5.0 Nominal Tons

Section	Description
---------	-------------

23 06 80	Schedules for Decentralized HVAC Equipment
-----------------	---

23 06 80.13	Decentralized Unitary HVAC Equipment Schedule
-------------	---

23 06 80.13.A.	Rooftop unit schedule
----------------	-----------------------

1. Schedule is per the project specification requirements.

23 07 16	HVAC Equipment Insulation
-----------------	----------------------------------

23 07 16.13	Decentralized, Rooftop Units:
-------------	-------------------------------

1. Interior cabinet surfaces shall be insulated with a minimum 3/4-in. thick, minimum 1-1/2 lb density, flexible fiberglass insulation bonded with a phenolic binder, with aluminum foil facing on the air side.
2. Insulation and adhesive shall meet NFPA 90A requirements for flame spread and smoke generation.

23 09 13	Instrumentation and Control Devices for HVAC
-----------------	---

23 09 13.23	Sensors and Transmitters
-------------	--------------------------

23 09 13.23.A.	Thermostats
----------------	-------------

1. Thermostat must
 - a. must include capability for occupancy scheduling.

23 09 33	Electric and Electronic Control System for HVAC
-----------------	--

23 09 33.13	Decentralized, Rooftop Units:
-------------	-------------------------------

23 09 33.13.A.	General:
----------------	----------

1. Shall be complete with self-contained low-voltage control circuit protected by a resettable circuit breaker on the 24-v transformer side. Transformer shall have 100VA capabilities.
2. Shall utilize color-coded wiring.
3. Shall include integrated defrost system to prevent excessive frost accumulation during heating duty, and shall be controlled as follows:
 - a. Defrost shall be initiated on the basis of Demand Defrost.
 - b. The need for a defrost cycle is determined by one of two factors: Time or Frost Detection.
 - c. Should six hours of compressor run time elapse without a defrost cycle and the coil temperature is below the frost accumulation temperature, a defrost cycle will be initiated.
 - d. The control shall be capable of detecting frost accumulation on the outdoor coil and initiate a defrost cycle when the Dry Coil Delta T + the Coil Temperature Dependant Variable (10 degrees of degradation) is sensed.
 - e. As the ambient temperature changes, the ambient change will be used to adjust the detection of frost accumulation.

23 09 33.23.B.	Safeties:
----------------	-----------

1. Compressor over-temperature, over current.
2. Loss of charge switch.
 - a. Loss of charge switch shall use different color wire than the high pressure switch. The purpose is to assist the installer and service technician to correctly wire and or troubleshoot the rooftop unit.
 - b. Loss of charge switch shall have a different sized connector than the high pressure switch. They shall physically prevent the cross-wiring of the safety switches between the high and low pressure side of the system.
3. High-pressure switch.
 - a. High pressure switch shall use different color wire than the low pressure switch. The purpose is to assist the installer and service person to correctly wire and or troubleshoot the rooftop unit.
 - b. High pressure switch shall have a different sized connector than the loss of charge switch. They shall physically prevent the cross-wiring of the safety switches between the high and low pressure side of the system.
4. Freeze protection sensor, evaporator coil.
5. Automatic reset, motor thermal overload protector.

23 09 93	Sequence of Operations for HVAC Controls
-----------------	---

23 09 93.13	Decentralized, Rooftop Units:
-------------	-------------------------------

23 09 93.13	SEE UNIT I & O FOR SEQUENCE OF OPERATION
-------------	--

23 40 13	Panel Air Filters
-----------------	--------------------------

23 40 13.13	Decentralized, Rooftop Units:
-------------	-------------------------------

23 40 13.13.A.	Standard filter section shall
----------------	-------------------------------

1. Shall consist of factory-installed, low velocity, throwaway 1-in. thick fiberglass filters of commercially available sizes.
2. Filters shall be accessible through an access panel as described in the unit cabinet section of this specification (23 81 19.13.H).

23 81 19 Self-Contained Air Conditioners

23 81 19.13 Small-Capacity Self-Contained Air Conditioners

23 81 19.13.A. General

1. Outdoor, rooftop mounted, electrically controlled, heating and cooling unit utilizing a(n) hermetic scroll compressor(s) for cooling duty and heat pump for heating duty.
2. Factory assembled, single-piece heating and cooling rooftop unit. Contained within the unit enclosure shall be all factory wiring, piping, controls, and special features required prior to field start-up.
3. Unit shall use environmentally sound R-410a refrigerant.
4. Unit shall be installed in accordance with the manufacturer's instructions.
5. Unit must be selected and installed in compliance with local, state, and federal codes.

23 81 19.13.B. Quality Assurance

1. Unit meets ASHRAE 90.1-2004 minimum efficiency requirements.
2. 3 phase units are Energy Star qualified.
3. Unit shall be rated in accordance with AHRI Standards 210/240 and 340/360.
4. Unit shall be designed to conform to ASHRAE 15, 2001.
5. Unit shall be UL-tested and certified in accordance with ANSI Z21.47 Standards and UL-listed and certified under Canadian standards as a total package for safety requirements.
6. Insulation and adhesive shall meet NFPA 90A requirements for flame spread and smoke generation.
7. Unit casing shall be capable of withstanding 500-hour salt spray exposure per ASTM B117 (scribed specimen).
8. Unit casing shall be capable of withstanding Federal Test Method Standard No. 141 (Method 6061) 5000-hour salt spray.
9. Unit shall be designed in accordance with ISO 9001:2000, and shall be manufactured in a facility registered by ISO 9001:2000.
10. Roof curb shall be designed to conform to NRCA Standards.
11. Unit shall be subjected to a completely automated run test on the assembly line. The data for each unit will be stored at the factory, and must be available upon request.
12. Unit shall be designed in accordance with UL Standard 1995, including tested to withstand rain.
13. Unit shall be constructed to prevent intrusion of snow and tested to prevent snow intrusion into the control box up to 40 mph.

23 81 19.13.C. Delivery, Storage, and Handling

1. Unit shall be stored and handled per manufacturer's recommendations.
2. Lifted by crane requires either shipping top panel or spreader bars.
3. Unit shall only be stored or positioned in the upright position.

23 81 19.13.E. Project Conditions

1. As specified in the contract.

23 81 19.13.F. Operating Characteristics

1. Unit shall be capable of starting and running at 115°F (46°C) ambient outdoor temperature, meeting maximum load criteria of AHRI Standard 210/240 or 340/360 at $\pm 10\%$ voltage.
2. Compressor with standard controls shall be capable of operation from 40°F (4°C), ambient outdoor temperatures. Accessory low ambient kit is necessary if mechanically cooling at ambient temperatures below 40°F (4°C).
3. Unit shall be capable of simultaneous heating duty and defrost cycle operation when using accessory electric heaters.
4. Unit shall discharge supply air vertically or horizontally as shown on contract drawings.
5. Unit shall be factory configured for vertical supply & return configurations.
6. Unit shall be field convertible from vertical to horizontal configuration.

23 81 19.13.G. Electrical Requirements

1. Main power supply voltage, phase, and frequency must match those required by the manufacturer.

23 81 19.13.H. Unit Cabinet

1. Unit cabinet shall be constructed of galvanized steel, and shall be bonderized and coated with pre-painted baked enamel finish on all externally exposed surfaces.
2. Unit cabinet exterior paint shall be: film thickness, (dry) 0.003 inches minimum, gloss (per ASTM D523, 60°F): 60, Hardness: H-2H Pencil hardness.
3. Evaporator fan compartment interior cabinet insulation shall conform to AHRI Standards 210/240 or 340/360 minimum exterior sweat criteria. Interior surfaces shall be insulated with a minimum 3/4-in. thick, 1 lb density, flexible fiberglass insulation, aluminum foil-faced on the air side.
4. Base of unit shall have locations for thru-the-base electrical connections (factory installed or field installed), standard.
5. Base Rail
 - a. Unit shall have base rails on all sides.
 - b. Holes shall be provided in the base rails for rigging shackles to facilitate maneuvering and overhead rigging.
 - c. Holes shall be provided in the base rail for moving the rooftop by fork truck.
 - d. Base rail shall be a minimum of 14 gauge thickness.
6. Condensate pan and connections:
 - a. Shall be a sloped condensate drain pan made of a non-corrosive material.
 - b. Shall comply with ASHRAE Standard 62.
 - c. Shall use a 1" -1 1/2 NPT drain connection, through the side of the drain pan. Connection shall be made per manufacturer's recommendations.

7. Top panel:
 - a. Indoor section shall be a single piece top panel.
 8. Electrical Connections
 - a. All unit power wiring shall enter unit cabinet at a single, factory-prepared, knockout location.
 - b. Thru-the-base capability
 - (1.) Standard unit shall have a thru-the-base electrical location(s) using a raised, embossed portion of the unit basepan.
 - (2.) No basepan penetration, other than those authorized by the manufacturer, is permitted.
 9. Component access panels (standard)
 - a. Cabinet panels shall be easily removable for servicing.
- 23 81 19.13.J. Coils
1. Standard Aluminum/Copper Coils: on all models.
 - a. Standard evaporator and condenser coils shall have aluminum lanced plate fins mechanically bonded to seamless internally grooved copper tubes with all joints brazed.
 - b. Evaporator and Condenser coils shall be leak tested to 150 psig, pressure tested to 550 psig, and qualified to UL 1995 burst test at 2,200 psig.
- 23 81 19.13.K. Refrigerant Components
1. Refrigerant circuit shall include the following control, safety, and maintenance features:
 - a. Thermal Expansion Valve (TXV) with venturi type distributor.
 - b. Refrigerant filter drier.
 - c. External service gauge connections to unit suction and discharge lines.
 2. Compressors
 - a. Unit shall use one fully hermetic, scroll compressor for each independent refrigeration circuit.
 - b. Compressor motors shall be cooled by refrigerant gas passing through motor windings.
 - d. Compressors shall be internally protected from high discharge temperature conditions.
 - e. Compressors shall be protected from an over-temperature and over-amperage conditions by an internal, motor overload device.
 - f. Compressor shall be factory mounted on rubber grommets.
 - g. Compressor motors shall have internal line break thermal, current overload and high pressure differential protection.
 - h. Crankcase heaters shall be utilized on all models to protect compressor with specific refrigerant charge.
- 23 81 19.13.L. Filter Section
1. Filters access is specified in the unit cabinet section of this specification.
 2. Filters shall facilitate easy removal and installation.
 3. Shall consist of factory-installed, low velocity, throw-away 1-in. thick fiberglass filters.
 4. Filters shall be standard, commercially available sizes.
 5. Filter face velocity shall not exceed 365 fpm at nominal airflows.
- 23 81 19.13.M. Evaporator Fan and Motor
1. Evaporator fan motor:
 - a. Shall have permanently lubricated bearings.
 - b. Shall have inherent automatic-reset thermal overload protection or circuit breaker.
 - c. Shall have a maximum continuous bhp rating for continuous duty operation; no safety factors above that rating shall be required.
 2. Belt-driven Evaporator Fan:
 - a. Belt drive shall include an adjustable-pitch motor pulley.
 - b. Shall use sealed, permanently lubricated ball-bearing type.
 - c. Blower fan shall be double-inlet type with forward-curved blades.
 - d. Shall be constructed from steel with a corrosion resistant finish and dynamically balanced.
- 23 81 19.13.N. Condenser Fans and Motors
1. Condenser fan motors:
 - a. Shall be a totally enclosed motor.
 - b. Shall use permanently lubricated bearings.
 - c. Shall have inherent thermal overload protection with an automatic reset feature.
 - d. Shall use a shaft-down design. Shaft-up designs including those with "rain-slinger devices" shall not be allowed.
 2. Condenser Fans:
 - a. Shall be a direct-driven propeller type fan.
 - b. Shall have blades riveted to corrosion-resistant steel spiders and shall be dynamically balanced.
- 23 81 19.13.O. Special Features, Options and Accessories
1. Integrated Economizers:
 - a. Integrated, gear-driven parallel modulating blade design type capable of simultaneous economizer and compressor operation.
 - b. Independent modules for vertical or horizontal return configurations shall be available. Vertical return modules shall be available as a factory installed option.

- c. Damper blades shall be galvanized steel with metal gears. Plastic or composite blades on intake or return shall not be acceptable.
 - d. Shall include all hardware and controls to provide free cooling with outdoor air when temperature and/or humidity are below setpoints.
 - e. Shall be equipped with gear driven dampers for both the outdoor ventilation air and the return air for positive air stream control.
 - f. Shall be capable of introducing up to 100% outdoor air.
 - g. Shall be equipped with a barometric relief damper capable of relieving up to 100% return air.
 - h. Shall be designed to close damper(s) during loss-of-power situations with spring return built into motor.
 - i. An outdoor single enthalpy sensor shall be provided as standard. Outdoor air sensor setpoint shall be adjustable and shall range from the enthalpy equivalent of 63°F @ 50% rh to 73°F @ 50% rh. Additional sensor options shall be available as accessories.
 - j. The economizer controller shall also provide control of an accessory power exhaust unit function. Factory set at 70%, with a range of 0% to 100%.
 - k. The economizer shall maintain minimum airflow into the building during occupied period and provide design ventilation rate for full occupancy. A remote potentiometer may be used to override the damper setpoint.
 - l. Dampers shall be completely closed when the unit is in the unoccupied mode.
 - m. Economizer controller shall accept a 2-10Vdc CO₂ sensor input for IAQ/DCV control. In this mode, dampers shall modulate the outdoor-air damper to provide ventilation based on the sensor input.
 - n. Compressor lockout sensor on the unit controller is factory set at 35°F and is adjustable from 30°F (-1°C) to 50°F (10°C) and resets the cooling lockout at 5°F (+2.7°C) above the set point.
 - o. Actuator shall be direct coupled to economizer gear. No linkage arms or control rods shall be acceptable.
 - p. Economizer controller shall provide indications when in free cooling mode, in the DCV mode, or the exhaust fan contact is closed.
 - q. Economizer wire harness will have provision for smoke detector.
 - r. Ultra Low Leak Dampers shall meet California Title 24 requirements.
 - s. Economizer controller shall meet California Title 24 FDD (Fault Detection and Diagnostics) requirements.
2. Two-Position Motorized Damper
 - a. Damper shall be a Two-Position Motorized Damper. Damper travel shall be from the full closed position to the field adjustable %-open setpoint.
 - b. Damper shall include adjustable damper travel from 25% to 100% (full open).
 - c. Damper shall include single or dual blade, gear driven dampers and actuator motor.
 - d. Actuator shall be direct coupled to damper gear. No linkage arms or control rods shall be acceptable.
 - e. Damper will admit up to 100% outdoor air for applicable rooftop units.
 - f. Damper shall close upon indoor (evaporator) fan shutoff and/or loss of power.
 - g. The damper actuator shall plug into the rooftop unit's wiring harness plug. No hard wiring shall be required.
 - h. Outside air hood shall include aluminum water entrainment filter
 3. Manual damper
 - a. Manual damper package shall consist of damper, air inlet screen, and rain hood which can be preset to admit up to 50% outdoor air for year round ventilation.
 4. Head Pressure Control Package
 - a. Controller shall control coil head pressure by condenser-fan cycling.
 5. Condenser Coil Hail Guard Assembly
 - a. Shall protect against damage from hail.
 - b. Shall be louvered design.
 6. Propeller Power Exhaust:
 - a. Power exhaust shall be used in conjunction with an integrated economizer.
 - b. Independent modules for vertical or horizontal return configurations shall be available.
 - c. Horizontal power exhaust is shall be mounted in return ductwork.
 - d. Power exhaust shall be controlled by economizer controller operation. Exhaust fans shall be energized when dampers open past the 0-100% adjustable setpoint on the economizer control.
 7. Roof Curbs (Vertical):
 - a. Full perimeter roof curb with exhaust capability providing separate air streams for energy recovery from the exhaust air without supply air contamination.
 - b. Formed galvanized steel with wood nailer strip and shall be capable of supporting entire unit weight.
 - c. Permits installation and securing of ductwork to curb prior to mounting unit on the curb.
 8. High-Static Indoor Fan Motor(s) and Drive(s):
 - a. High-static motor(s) and drive(s) shall be factory-installed to provide additional performance range.
 9. Outdoor Air Enthalpy Sensor:
 - a. The outdoor air enthalpy sensor shall be used to provide single enthalpy control. When used in conjunction with a return air enthalpy sensor, the unit will provide differential enthalpy control. The sensor allows the unit to determine if outside air is suitable for free cooling.

10. Return Air Enthalpy Sensor:
 - a. The return air enthalpy sensor shall be used in conjunction with an outdoor air enthalpy sensor to provide differential enthalpy control.
11. Indoor Air Quality (CO₂) Sensor:
 - a. Shall be able to provide demand ventilation indoor air quality (IAQ) control.
 - b. The IAQ sensor shall be available in wall mount with LED display. The setpoint shall have adjustment capability.
12. Electric Heat:
 - a. Heating Section
 - (1.) Heater element open coil resistance wire, nickel-chrome alloy, strung through ceramic insulators mounted on metal frame. Coil ends are staked and welded to terminal screw slots.
 - (2.) Heater assemblies are provided with integral fusing for protection of internal heater circuits not exceeding 48 amps each. Auto reset thermo limit controls, magnetic heater contactors (24 v coil) and terminal block all mounted in electric heater control box (minimum 18 ga galvanized steel) attached to end of heater assembly.

BEFORE PURCHASING THIS APPLIANCE, READ IMPORTANT ENERGY COST AND EFFICIENCY INFORMATION AVAILABLE FROM YOUR RETAILER.

GENERAL TERMS OF LIMITED WARRANTY*

Rheem will furnish a replacement for any part of this product which fails in normal use and service within the applicable periods stated, in accordance with the terms of the limited warranty.

***For complete details of the Limited and Conditional Warranties, including applicable terms and conditions, contact your local contractor or the Manufacturer for a copy of the product warranty certificate.**

Conditional Parts (Registration Required)

1 Phase, Residential ApplicationsTen (10) Years

Compressor

1 Phase, Residential Applications.....Ten (10) Years

1 & 3 Phase, Commercial ApplicationsFive (5) Years

Parts

1 & 3 Phase, Commercial ApplicationsOne (1) Year



The new degree of comfort.™

In keeping with its policy of continuous progress and product improvement, Rheem reserves the right to make changes without notice.

Rheem Heating, Cooling & Water Heating • P.O. Box 17010
Fort Smith, Arkansas 72917 • www.rheem.com

Rheem Canada Ltd./Ltée • 125 Edgeware Road, Unit 1
Brampton, Ontario • L6Y 0P5



INTEGRATED AIR & WATER

PRINTED IN U.S.A 7/18 QG FORM NO. P11-796 REV. 1