

# Variable Refrigerant Flow (VRF) Multi-Zone Systems

Commercial Catalog 2017



- One System - Up to 36 Zones
- Easy Installation
- Quiet Operation
- Energy Efficient
- Compact Modular Design

 **Mammoth**<sup>®</sup>



**Smart technology for efficient comfort.**



**Why choose Mammoth?**



For over 80 years, the Mammoth brand has been creating a comfortable indoor climate for both industrial and commercial customers around the world. Mammoth manufactures custom commercial products that include factory-packaged rooftop systems, pre-fabricated mechanical equipment rooms and direct replacement rooftop units. All of these different products strive to improve air quality and reduce operating costs.

## Contents

	Page		Page		Page
Product Offering	4	V5 Outdoor Units	29-39	VRF Accessories	65-76
Variable Refrigerant Flow (VRF)	6	- V5 Outdoor Unit Nomenclature	29	- Selection Software	66
Modular Design Flexibility	7	- V5 Mini Heat Pumps	30	- Fresh Air Processing	75
Simple Installation	10	- V5 Heat Pump Outdoor Units	36	VRF Controls	77-92
Superior Comfort	13	V5 Heat Recovery System	39	- Debugging Software	83
High-Efficiency Energy Savings	17	V5 Branching Units	45	- Wired Controllers and Remote Controllers	86
Proven Reliability	23	V5 Indoor Units	46-64	- BACnet Gateway	90
Easy Maintenance & Service	28			- Modbus Gateway	91
				- Control System Lineup	92

## Product Offering



Mammoth VRF condensers are available in 6, 8 and 10 Tons. These base model condensers can also be combined to make systems with capacities ranging from 6 Tons all the way up to 20 Tons (30 Tons Heat Pump systems only). Indoor unit combinations range from 13 indoor units all the way up to 36 indoor units. The minimum and maximum number of indoor units is determined by the system's connectable capacity. The connectable capacity range for heat pump systems is 50% to 135% of the capacity rating of the outdoor unit. The connectable capacity range for heat recovery is 50% to 150%. The collective capacity rating of indoor units must fall within the connectable capacity range for the system to function correctly.

Cooling Capacity		Heating Capacity Need	Combine Unit Sizes			Maximum Indoor Unit Connections
MBH	Tons	MBH	V5BV-224(72)	V5BV-280(96)	V5BV-335(120)	
<b>Single Outdoor Unit</b>						
72	6	81	1			13
96	8	108		1		16
120	10	135			1	20
<b>Multiple Linked, Outdoor Units (Tons)</b>			6	8	10	
144	12	162	2			23
168	14	189	1	1		26
192	16	216		2		29
216	18	243		1	1	33
240	20	270			2	36
264*	22	297	1	2		26
288*	24	324		3		29
312*	26	351		2	1	33
336*	28	378		1	2	36
360*	30	405			3	33

Note: Some combinations pending approvals. Please check AHRI directory for approved combinations.

\* Heat Pump systems only





# Variable Refrigerant Flow (VRF) Technology



## What is VRF?

Variable Refrigerant Flow (VRF) systems move refrigerant to multiple indoor fan coil units, each with its own control. This allows building occupants to meet their individual comfort needs without the energy loss associated with moving air through ductwork.

Mammoth VRF systems are inverter-driven, allowing the system to soft start and consume less energy. Mammoth VRF systems also modulate capacity according to demand, using the least amount of energy possible to meet the heating and cooling needs in specific areas.

VRF systems provide the ultimate in comfort, design flexibility, simple installation and energy savings:

- Excellent payback potential
- True zone control
- Minimized installation costs (no large ductwork; no cranes; no large bundles of piping and wire)
- Very quiet operation

## Where can VRF be used?

VRF systems can be used anywhere separate zoning and energy savings are priorities:

- Schools and Universities
- Healthcare Facilities
- Day Care Centers
- Hotels
- Retail Strip Centers
- Renovation and Additions
- Office Buildings
- Museums
- Apartments
- Airports

## Modular Design Flexibility

Outdoor condensers can be used individually or easily linked in a wide variety of combinations from 6 to 20 (6 to 30 Heat Pump only) tons. Seven different indoor unit styles in capacities ranging from 7K BTU to 60K BTU allow for thousands of combinations to suit any décor and accommodate almost any commercial application.



Combine units for a maximum of 20 Tons (30 Tons Heat Pump only)

## Wide Operating Temperature Range

Mammoth VRF systems have one of the widest temperature operating ranges in the industry, allowing for low ambient cooling down to 23°F (-5°C) and low ambient heating all the way down to -4°F (-20°C).

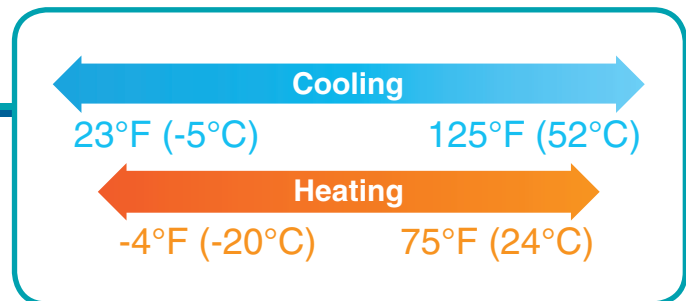

# Modular Design Flexibility

## 3280ft (1000m) Pipe Design

The simple piping design means Mammoth VRF systems can be installed in a variety of building types. It also makes installation easy which reduces installation costs.

- Maximum 3300ft (1000m) of piping [see note]
- Maximum 541ft (165m) pipe length from the outdoor unit and the furthest indoor unit
- Maximum height from indoor unit and outdoor unit is 295ft (90m)

**Note:** 3280ft(1000m) is the total system piping length in one direction. The maximum piping length from the first branch to the farthest indoor unit is 131ft(40m).

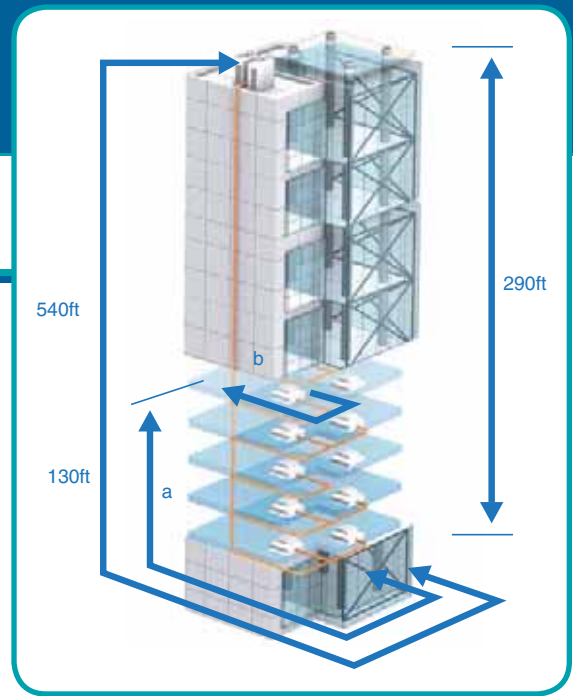

## Ultra Long Connection Pipe for More Convenient Installation

By adding a subcooler, with built-in subcooler circuits, the indoor and outdoor unit(s) can operate reliably with longer connection pipe.

	Competitive Models	Mammoth Mini
Total Piping Length	500ft 150m	393ft 120m
Equivalent Piping Length	225ft 70m	492ft 150m



## Wide Range of Zone Applications

Three outdoor units can be combined with up 36 indoor units for a greater number of individual zone comfort levels.

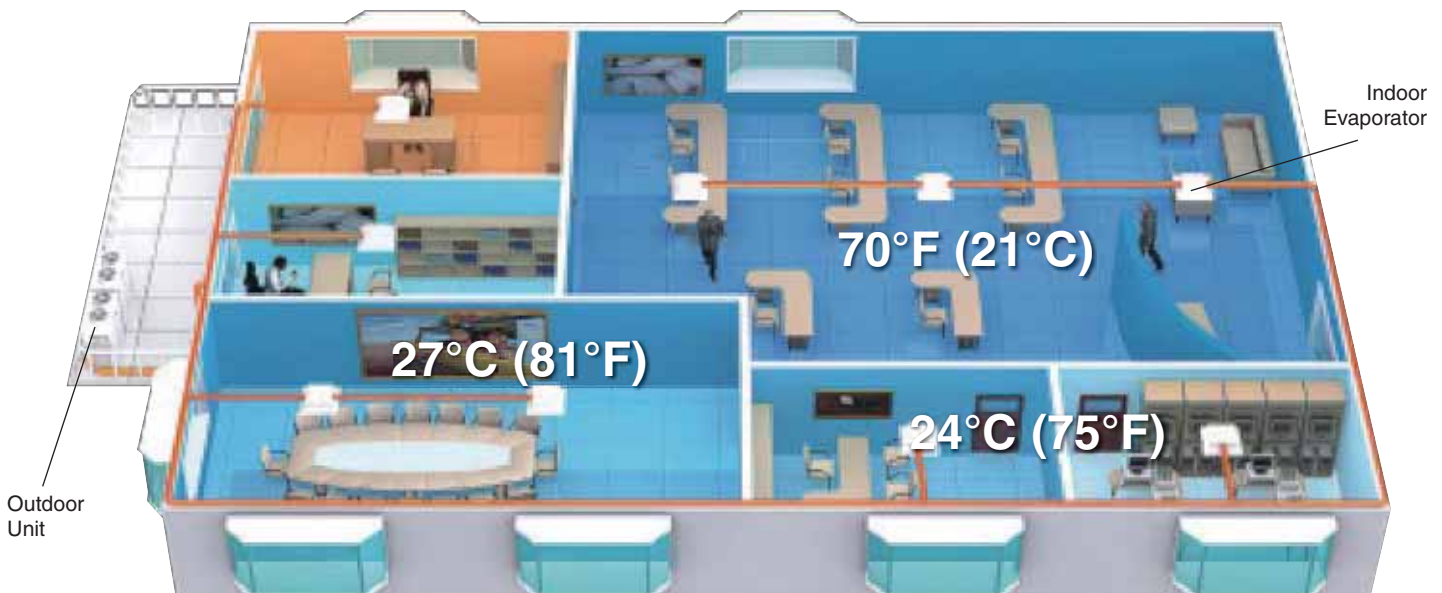



# Modular Design Flexibility

## High Static Pressure

The system has four settings of static pressure that can be set up to .33" wc (82Pa). This design is especially useful when an outdoor unit needs to be placed indoors.



## Seasonal Settings

The system can be set to cooling only or heating only mode if desired. This option can provide safety and increased energy savings.

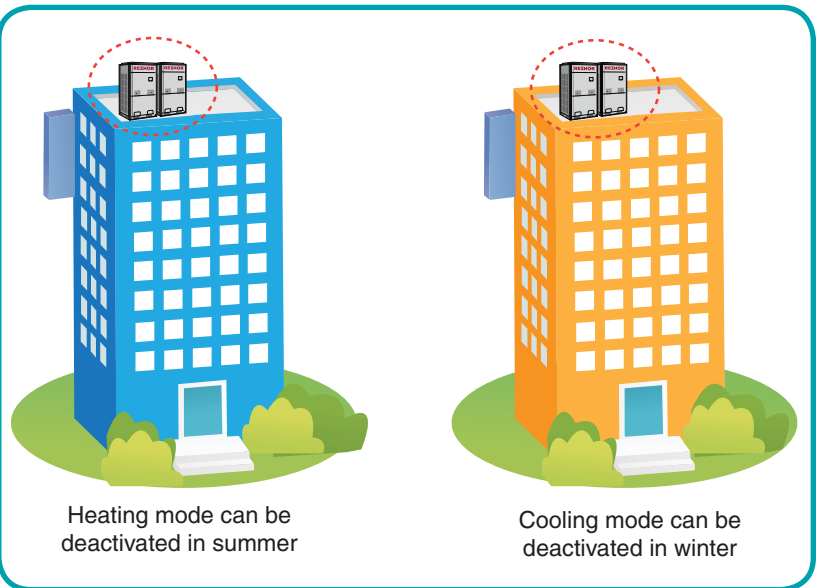

## Key-Card Control

For hotel applications Mammoth offers a key card controller. When the key card is inserted the unit is ON. When key card is removed the unit is OFF. If the key card is removed the settings are stored in memory.

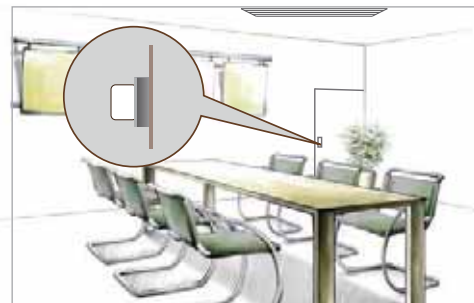

# Simple Installation

When compared with conventional systems of the same capacity, Mammoth VRF units are smaller and lighter for easier installation. The smaller size also allows for easier movement around job site. There's no need to hire expensive cranes or forklifts. Units can be transported to the roof via elevator.



## Lighter Weight and Compact Design

Smaller, modular design of the outdoor unit allows for units to be carried to the roof via elevator. A conventional outdoor system would require a crane.

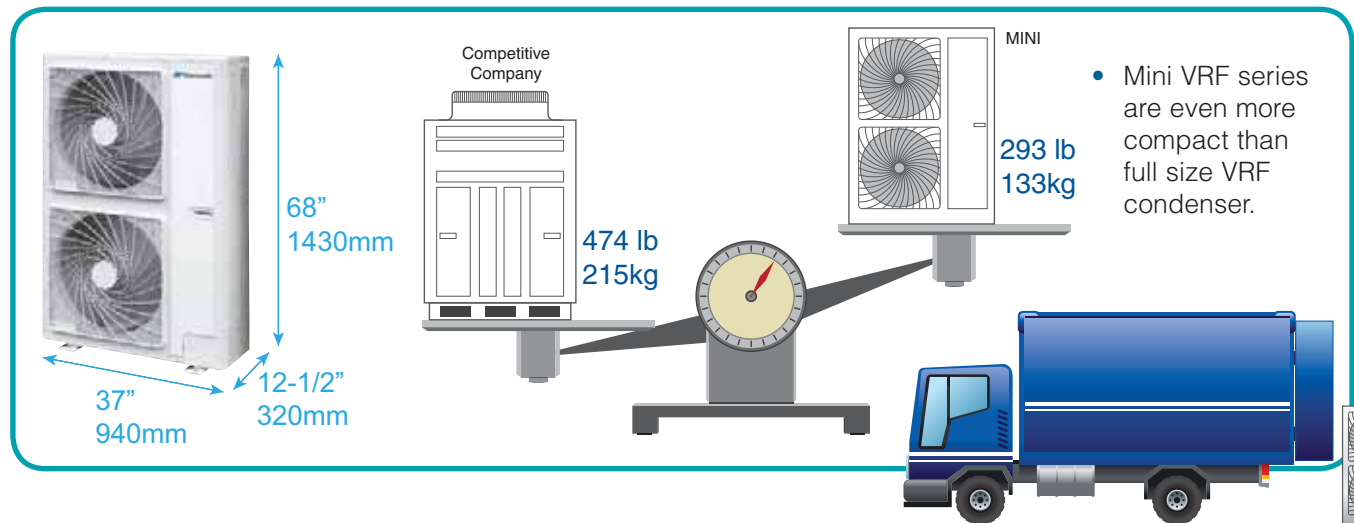

## Easy Transportation

### Base Frame Rails

Built-in base rail frame makes for easy lifting and installation with a hoist, and easy transportation with a forklift.

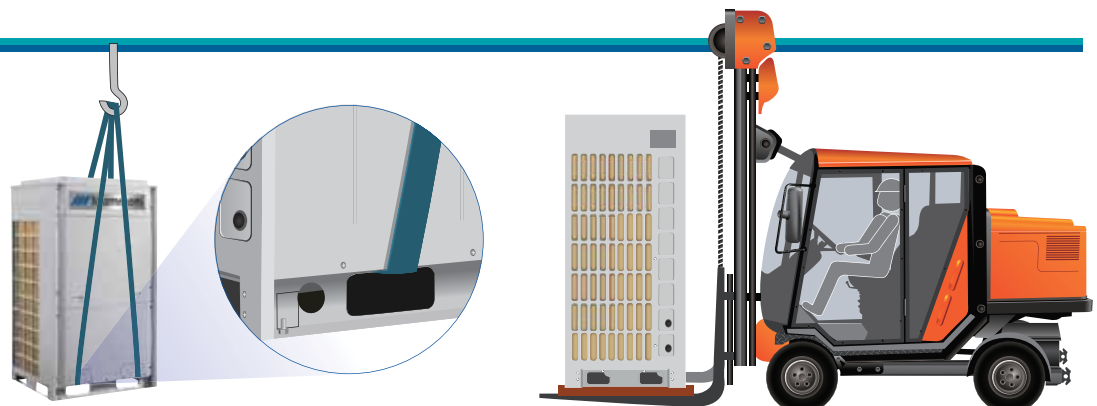

# Simple Installation

## Flexible Wiring

There is no polarity requirement, so common sheath twisted pair cable can be used saving time and money and simplifying installation.

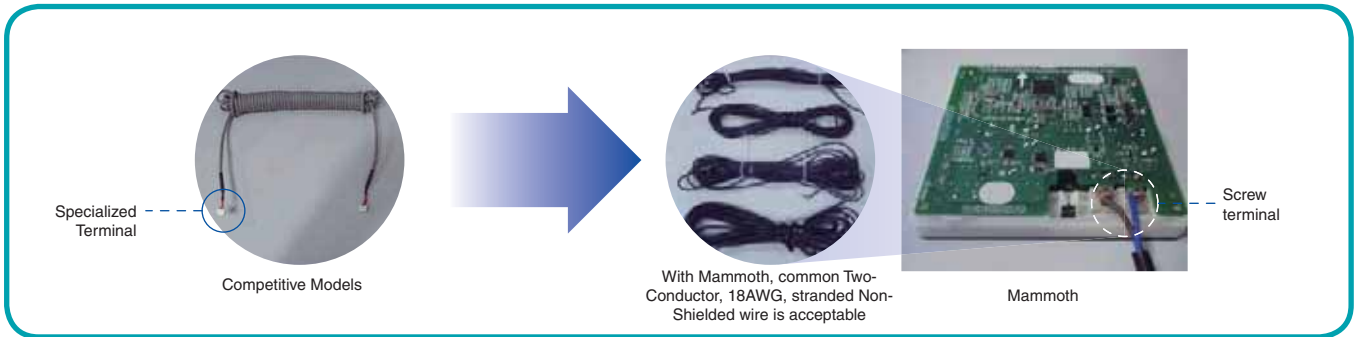

## Non-Polar CAN Technology to Improve Communications

An industry first. Non-polar CAN communication provides quicker system response time reducing service time and providing more reliable data.

Performance Index	Competitive Models Multi-VRF Network	Mammoth DC Inverter CAN Network
Reliability	Software check	Hardware check, more reliable
	One unit's communication error will shut down the entire system	If one unit has error, it will exit from the network without affecting other units
Communication Efficiency	Low performance	High performance
	Communication speed is about 10Kbps	Communication speed is about 20Kbps
Compatibility	One main network, difficult to add new equipment	Multiple networks, easy to add new equipment
Communication Distance	3280ft (1000m)	4921ft (1500m)

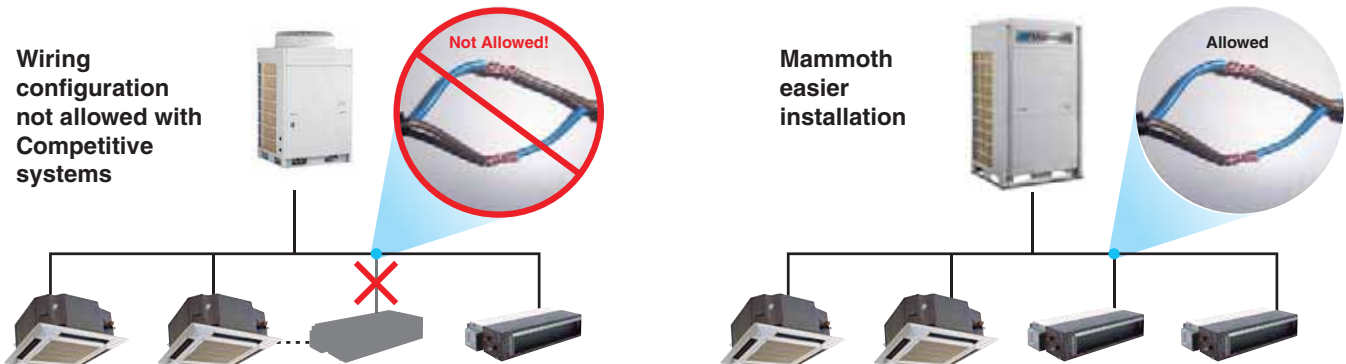

# Simple Installation

## Auto Addressing of Outdoor Unit and Indoor Unit

Debugging software is used for auto-addressing of outdoor and indoor units. It can detect indoor unit and outdoor unit quantity and automatically allocate addresses. System can emit an audible tone in a specific indoor unit for easy identification by a technician.

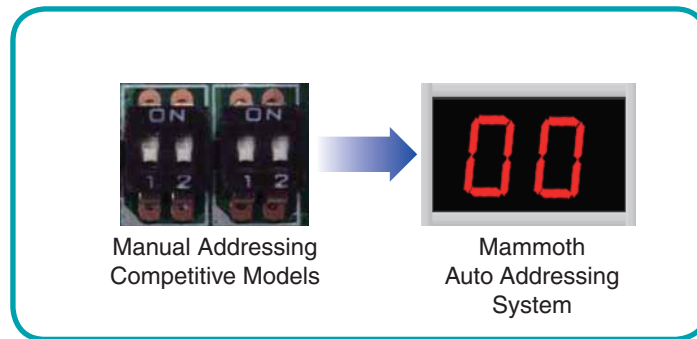

## Intelligent Debugging for Convenient Installation

- Automatic recognition of indoor unit and outdoor unit locations
- Automatic detection of the number of indoor unit and outdoor unit quantity
- Automatic detection of error signal
- Automatic troubleshooting startup
- Real-time analysis of pipe error signal
- Audible tone sounds on indoor unit for troubleshooting

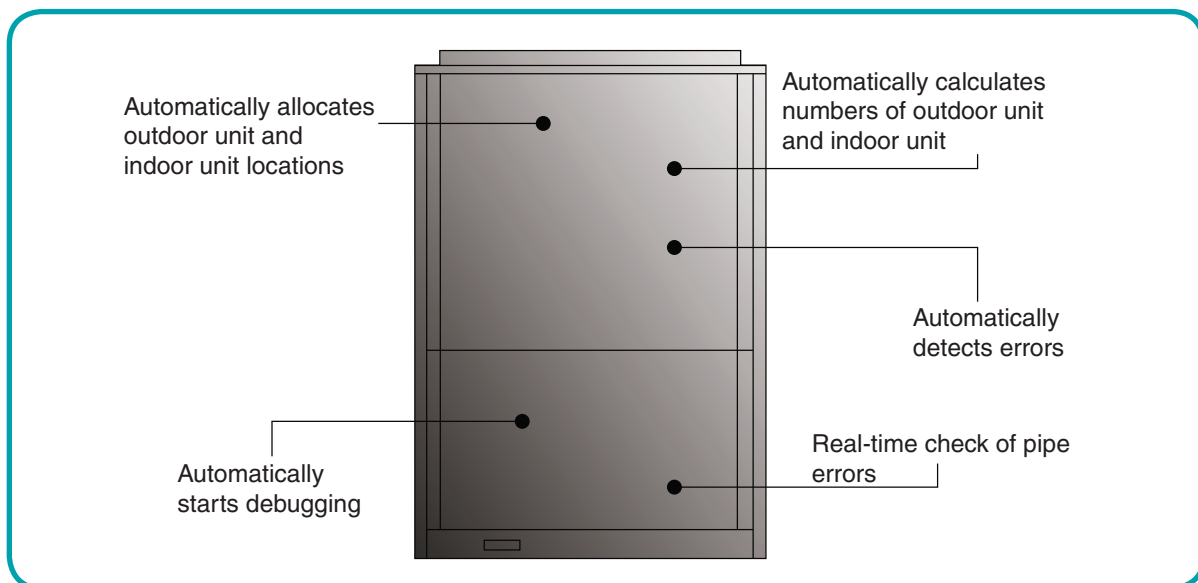

# Superior Comfort

## Intelligent Defrosting Design

The Mammoth system uses an intelligent learning mode to sense when defrosting is required. This improves performance and increases energy efficiency.

Conventional system will engage defrost mode at set intervals. This affects the efficiency and performance of the system and reduces the comfort level of the occupants.

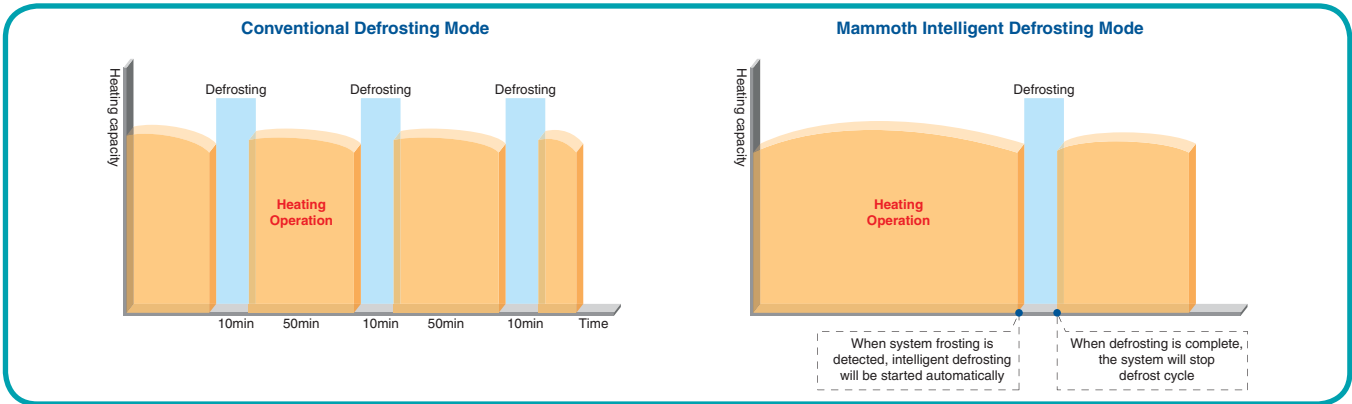

## Refrigerant Storage and Distribution

These units have refrigerant adjustment tanks and accumulators for the purposes of refrigerant storage, which in turn provides better refrigerant control, and lowers the amount of refrigerant necessary to run the system.

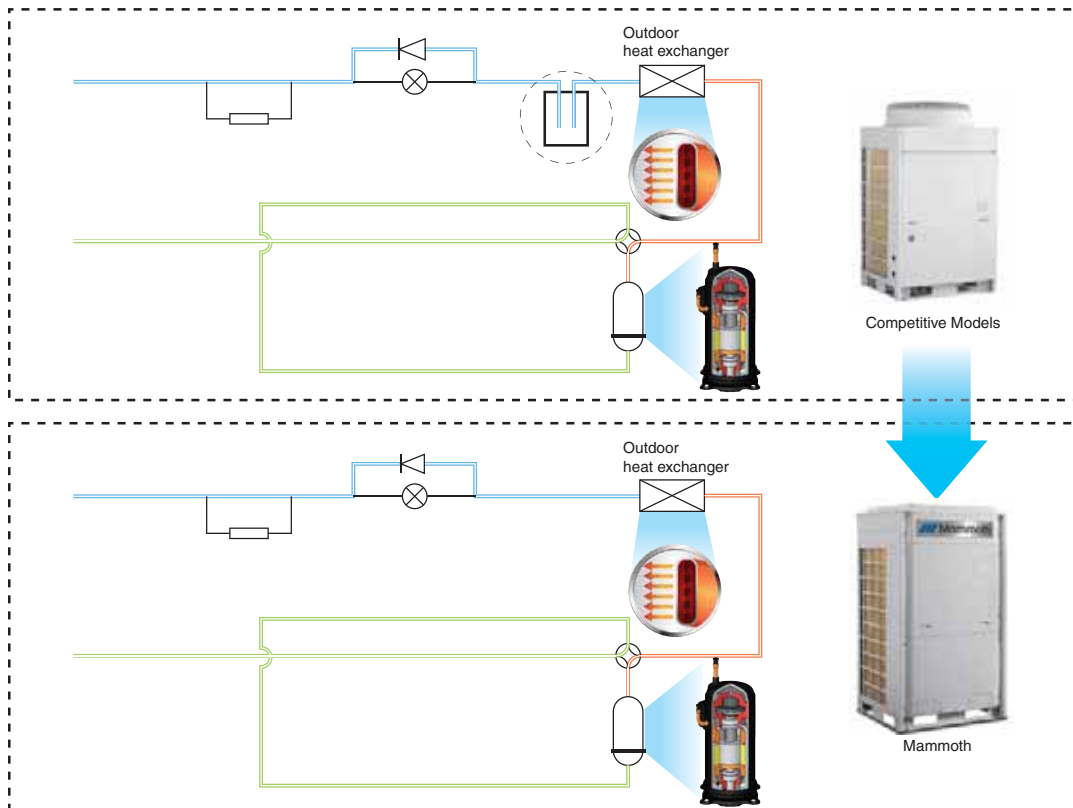

# Superior Comfort

## Sub-Cooling Control Technology

The control system ensures a full column of liquid to all indoor unit expansion valves. The primary method shown (below top) ensures 20°F (11°C) liquid subcooling to the indoor units. The condenser also has a secondary subcooling technology that assures a 16°F (9°C) liquid subcooling in any weather condition (below bottom). And in heat recovery systems, each Mode Exchange Unit has its own subcooling circuit, ensuring a full column of liquid to the units calling for cooling.

In all weather conditions the indoor units will have proper liquid refrigerant available for heating or cooling.

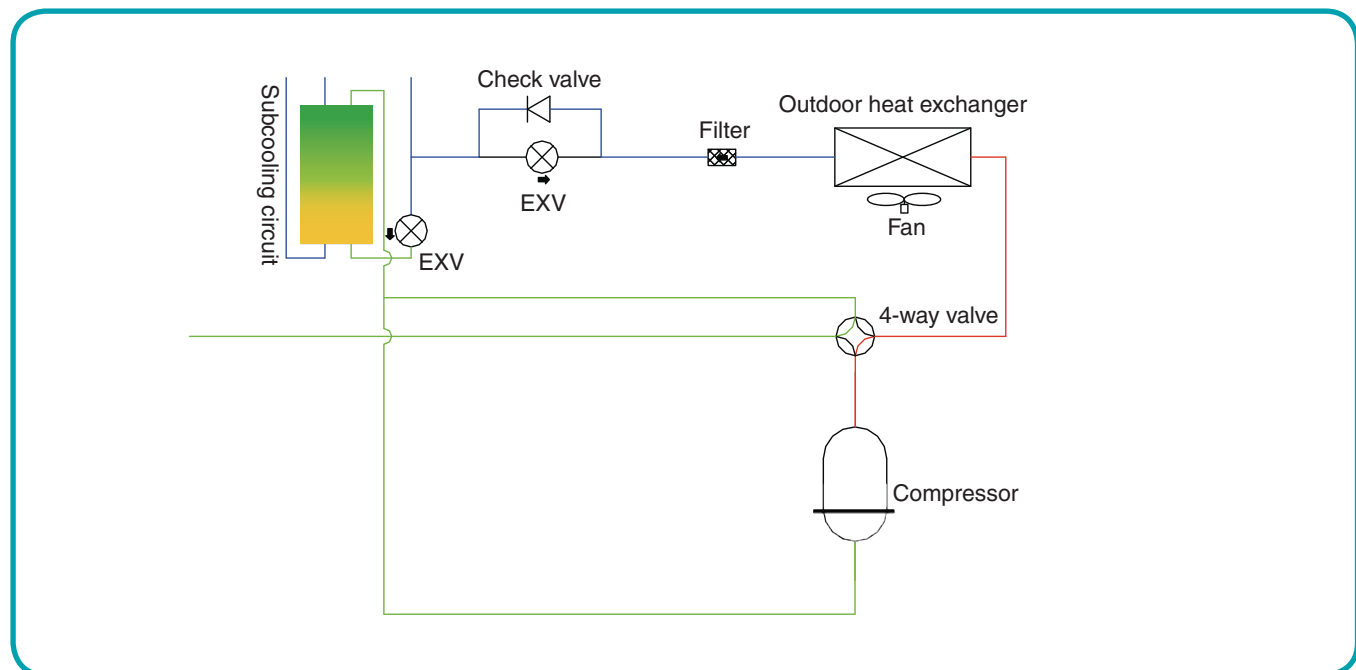
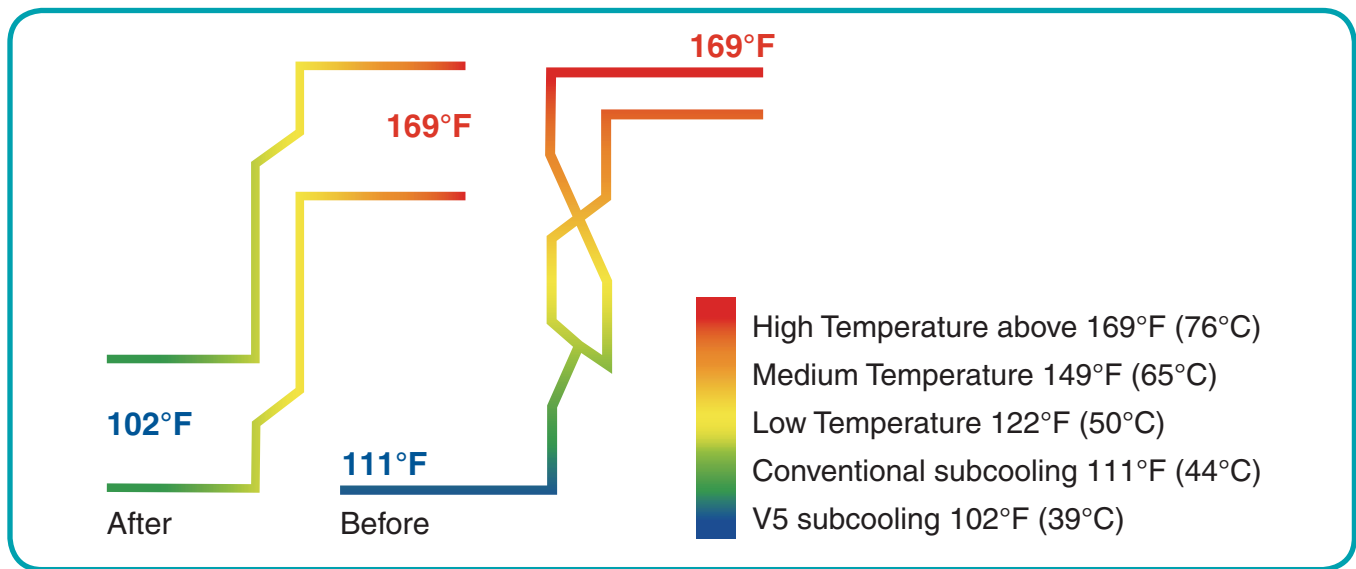

# Superior Comfort

## Quiet by Design

Mammoth VRF outdoor units have two modes for quiet operation.

### Quiet Night

The Quiet Night mode can sense the ambient temperature setting and automatically adjust to quiet mode during the cooler night time temperatures. There are nine different settings under Quiet Night mode.

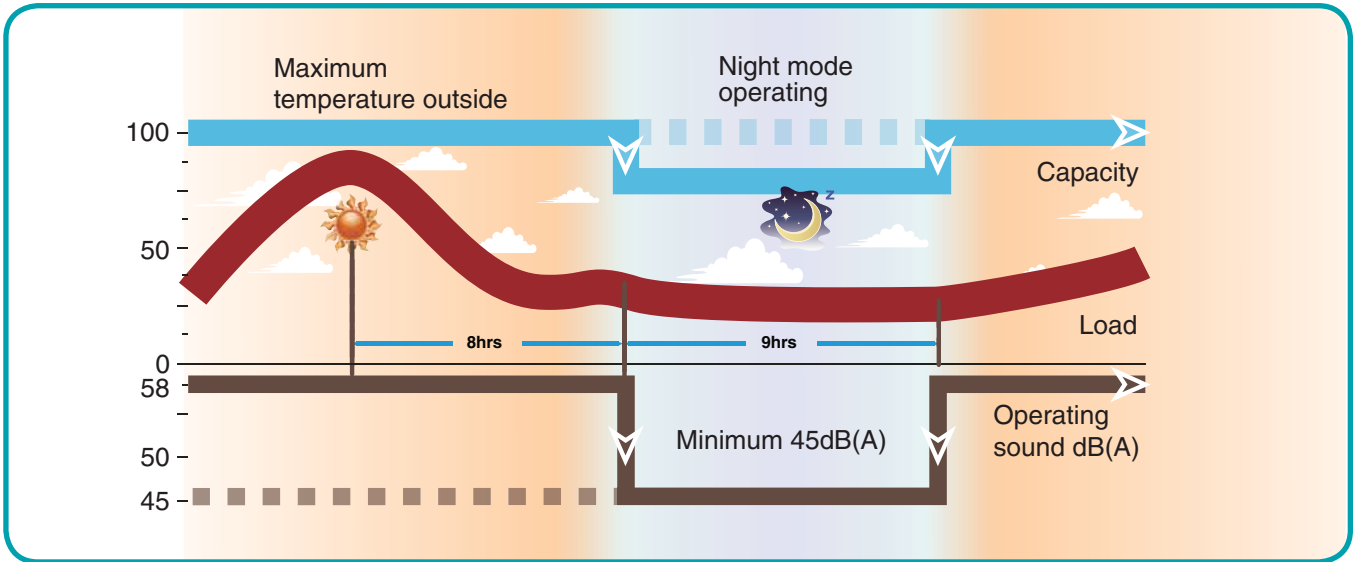

### Forced Quiet

In Forced Quiet mode the system can be set at constant quiet operation. The sound level can be set as low as 45dB(A).

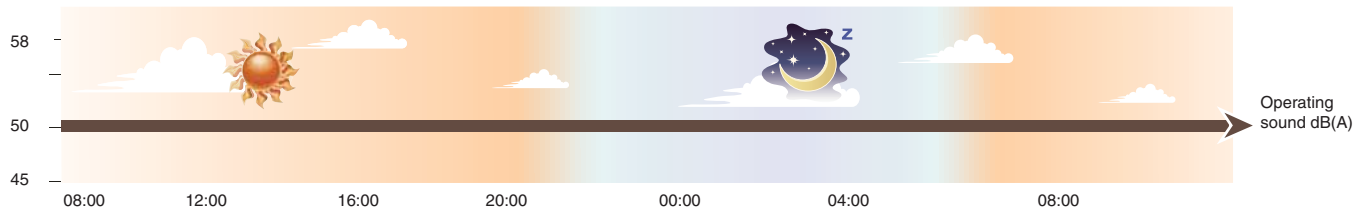

## Quiet Control

The new fan bossing structure is designed to reduce vibration. The sound level can be reduced by 3dB(A).

### Aerodynamic 3D Axial Fan

The aerodynamic axial fan was designed to increase airflow volume by 12%. More air is moved at lower power, increasing efficiency and reducing sound level.

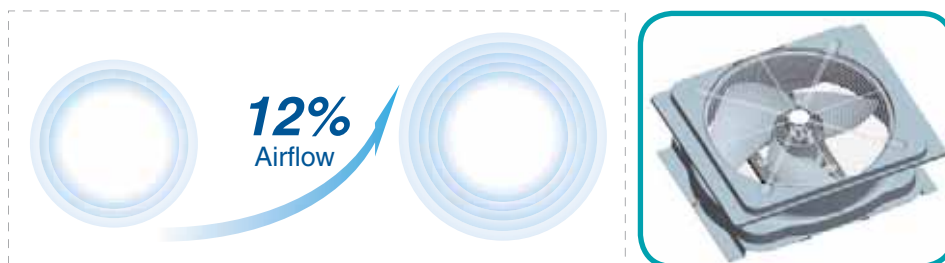

# Superior Comfort

## Quiet Indoor Operation

The indoor unit system also uses DC inverter motors to realize stepless regulation. The sound level can be as low as 22dB(A).

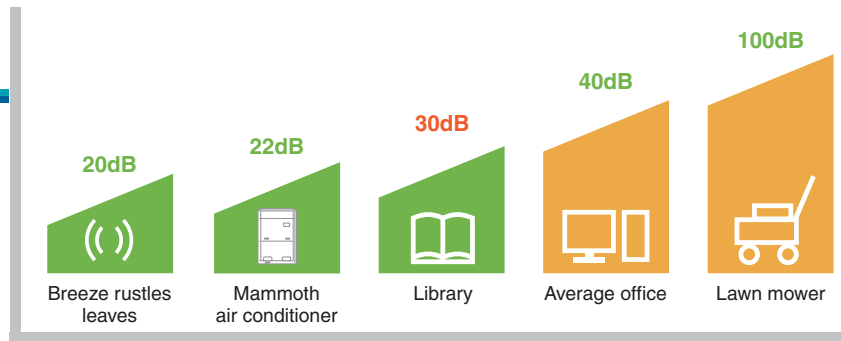

## Fast Start-Up Heating

The DC inverter compressor can be powered on and operated at a high frequency to produce more heat more quickly.

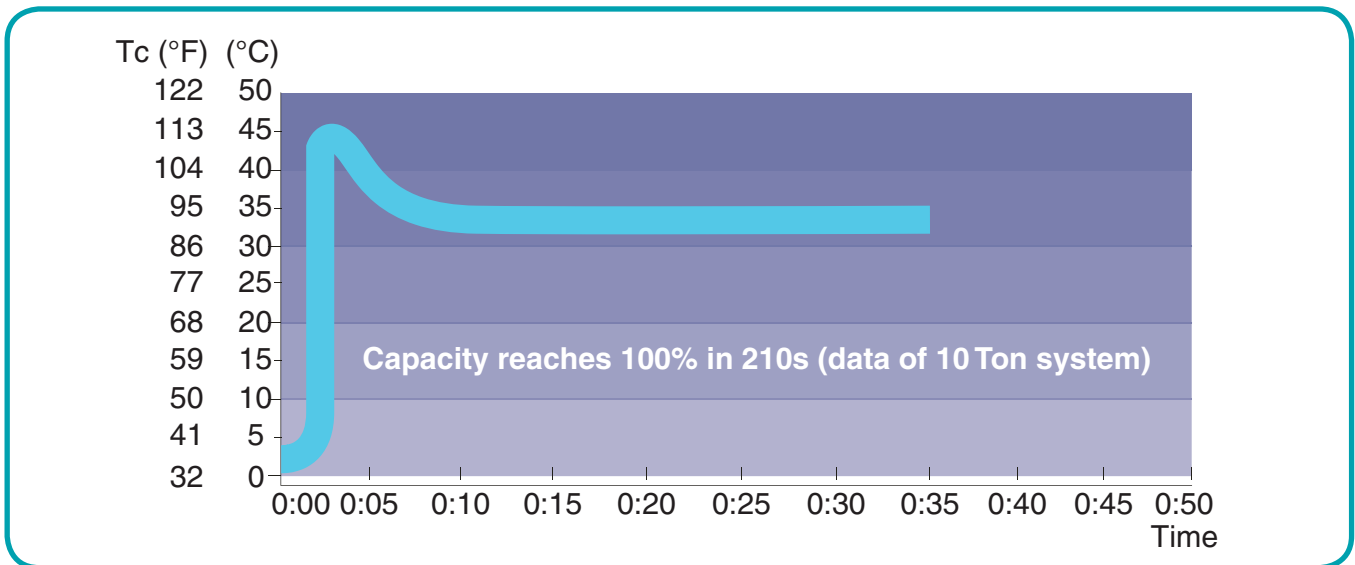

## Seven Indoor Unit Fan Speeds

The optional wired controller has settings for seven fan speeds from low to turbo. Simply press the "FAN" button to select the desired fan speed.

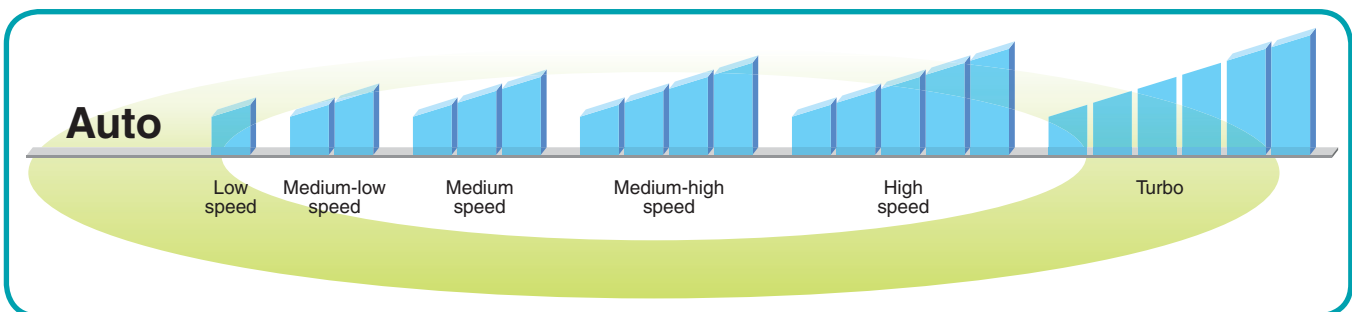



# High-Efficiency Energy Savings

## High-Efficiency Energy Saving and More

With the advance all DC inverter optimized system design and accurate, intelligent control, the IEER of the this system is up to 28.1.

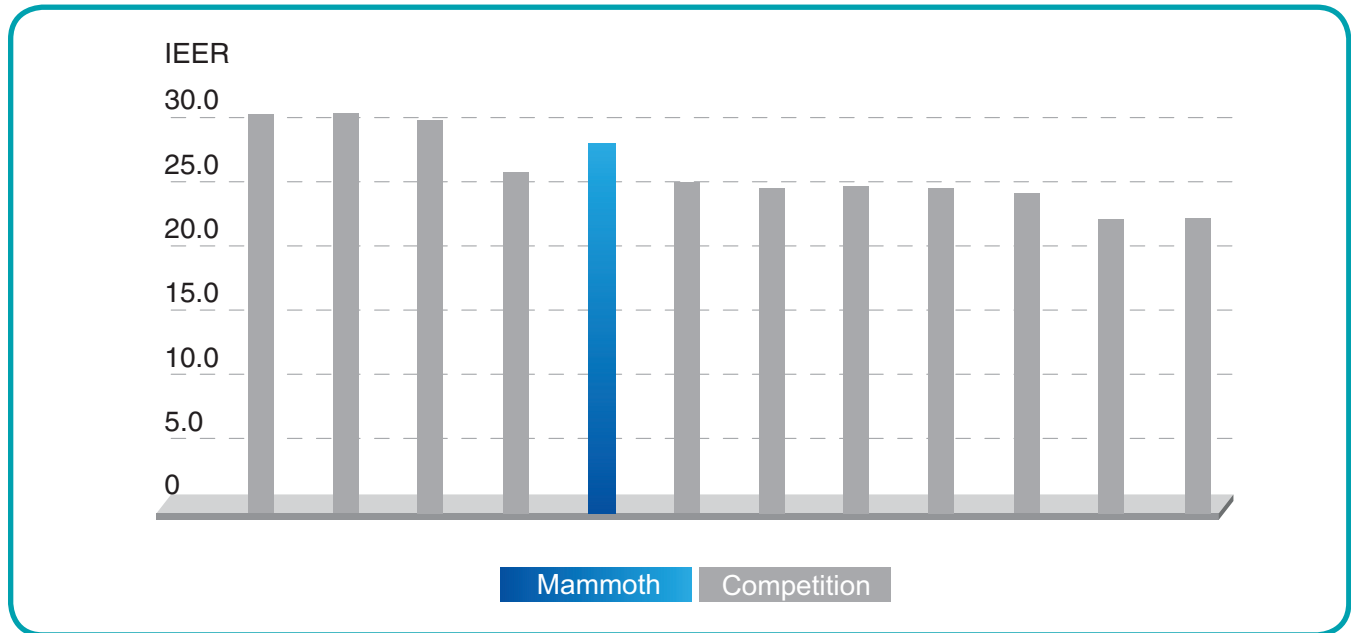

## Efficiency Definitions

**Coefficient of Performance (COP):** a measure of efficiency that compares energy input to energy output at one temperature

**Energy Efficiency Ratio (EER):** a measure of efficiency that compares the energy consumption and output at a few temperatures rather than one

**Simultaneous Cooling and Heating Efficiency (SCHE):** the energy efficiency of a unit that uses the same system to both heat and cool; used exclusively with heat recovery systems.

**Integrated Energy Efficiency Ratio (IEER):** the most accurate efficiency rating; shows how a system performs at varying loads

### How do we stack up?

EER shows a more accurate picture of efficiency than COP. However, it is calculated using indoor units that are running at a fairly high load. So, like with COP, companies can engineer their equipment to meet EER specifications to produce better numbers, but it does not offer the most accurate real world rating

We exceed expectations in arguably the most important area – value. SCHE and IEER are considered more accurate ratings for variable-capacity systems. SCHE is used exclusively with heat recovery systems and is the whole basis for purchasing a heat recovery system. IEER is the most accurate rating and shows how efficient a system is when it does not need 100% capacity, which is almost ALL the time. If you compare our ratings to competitors, we would be considered middle-of-the-pack. However, because we offer our units at a more competitive price point, the efficiency differences seem negligible.

# High-Efficiency Energy Savings

## Energy Saving Operation Control Options

Though Mammoth VRF systems offer tremendous energy savings in standard operation mode, the system is equipped with two additional selectable energy saving modes.

In auto energy-saving mode, the system will adjust itself based on operation status to lower electricity usage up to 15%.

In compulsory energy-saving mode, the system will automatically restrict power consumption by up to 20%. This means you spend less and keep more in your pocket.

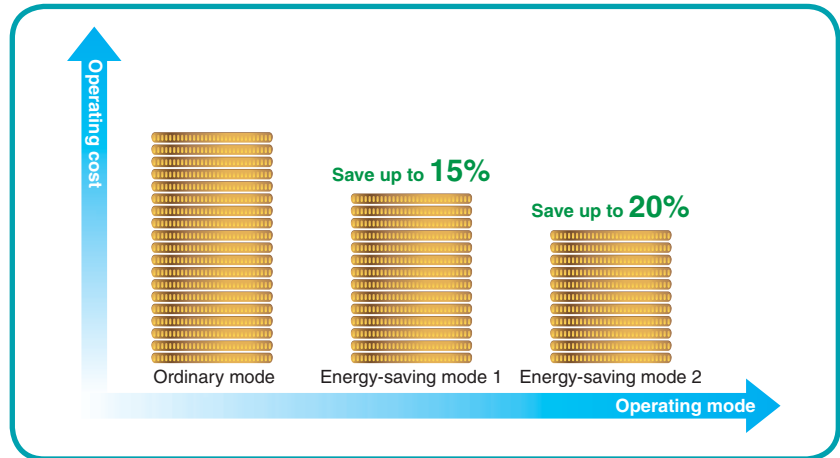

## What is a Compressor High-Side Pressure Chamber?

### High-Side Shell Scroll Compressor

The low-temperature and low-pressure refrigerant gas from the suction inlet of the compressor will change to high-temperature and high-pressure vapor after compression. Then the vapor will exit at the center of fixed scroll to the lower chamber of compressor, so that the compressor chamber is in high pressure.

### What are the benefits of a High-Side Shell?

The High-Side shell design forces oil into the plates using pressure. The greater the pressure difference, the more oil is forced onto the plates, meaning that the compressor always has the lubrication it needs. Compressor discharges directly in to the shell of the compressor creating improved compression efficiency.

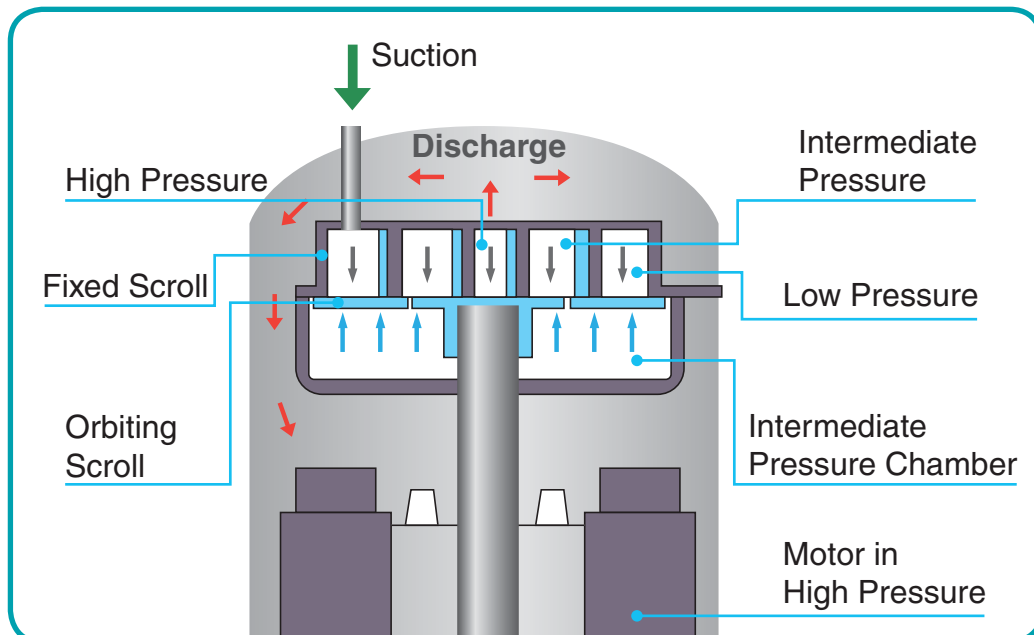

# High-Efficiency Energy Savings

## All DC Inverter Technology to Improve Compression Efficiency

All DC inverter compressor and high-performance high-side shell compressor are adopted to reduce overheat suction loss and improve compression efficiency from direct intake. Compared with low pressure chamber, the compression efficiency is improved. High-efficient permasyon motor is adopted to provide better performance than traditional DC inverter compressor.

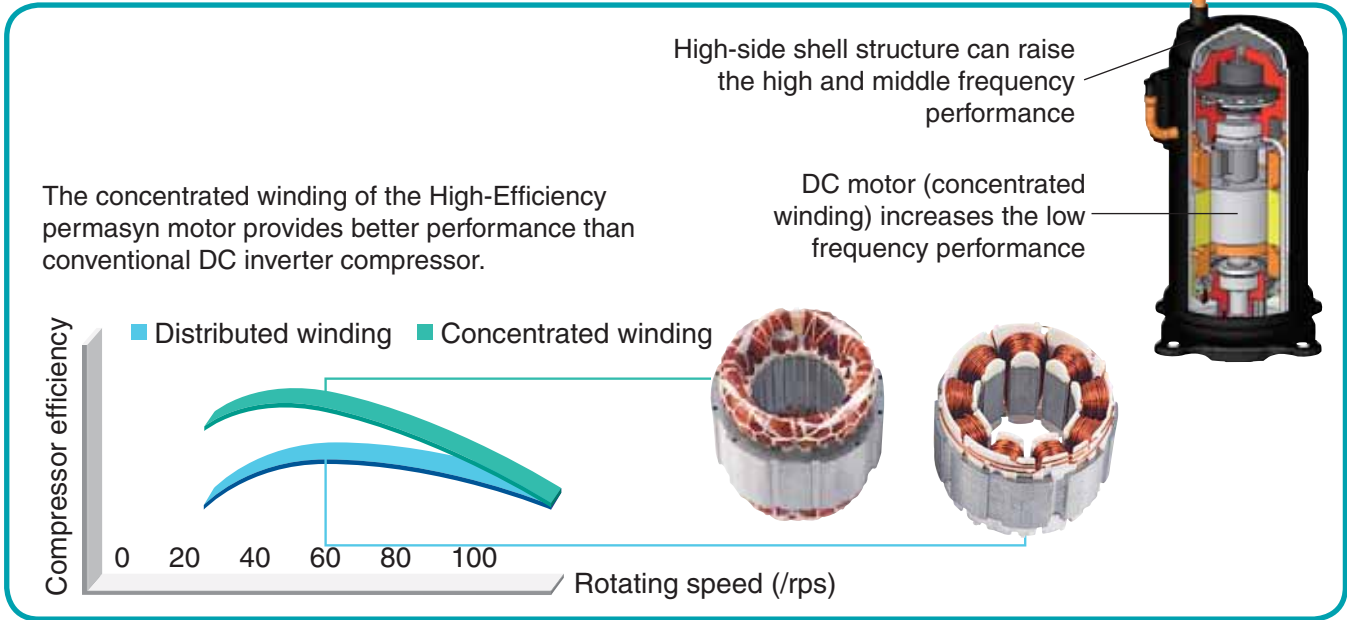

## Sensorless DC Inverter Fan Motor

Stepless speed regulation ranges from 5 Hz to 65 Hz. Sensorless control produces less vibration, lower sound levels, and is more energy efficient than conventional motors.

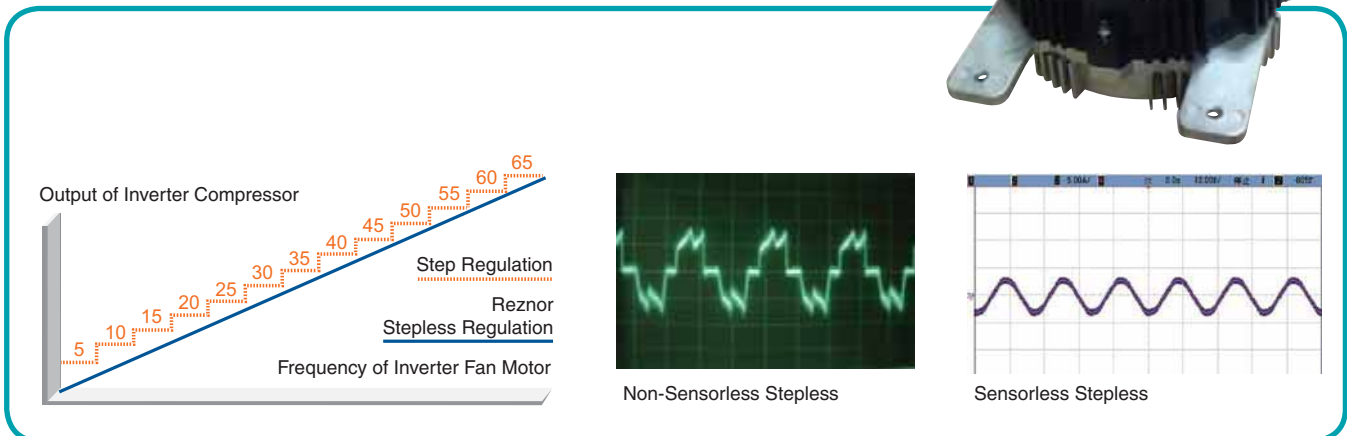

# High-Efficiency Energy Savings

## Accurate Intelligent Allocation of Capacity

When total load demand is more than 75% of an energized module capacity, the next module will automatically start. When total load demand drops below 40% of energized modules capacity, one module will automatically shut off. Each unit shares 40%-70% of the total load.

Testing shows that this is the most efficient operational range.

## Intelligent Fan Cycling Ensures Highest Efficiency

The DC inverter compressor and DC inverter fan also share the load for more energy savings.



Competitive Models



Mammoth

Allocation Method	10 Ton (full load) + 6 Ton (low load)	8 Ton (partial load) + 8 Ton (partial load)
Performance Compared	System uses more energy and may wear out quicker.	System uses less energy longer life.

# High-Efficiency Energy Savings

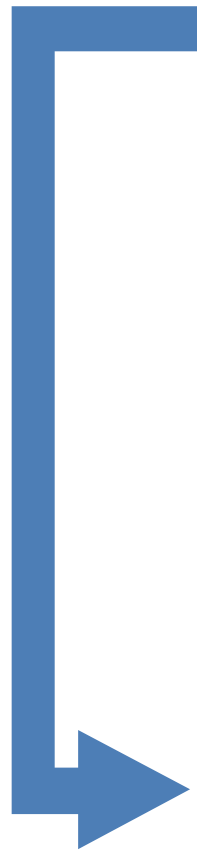
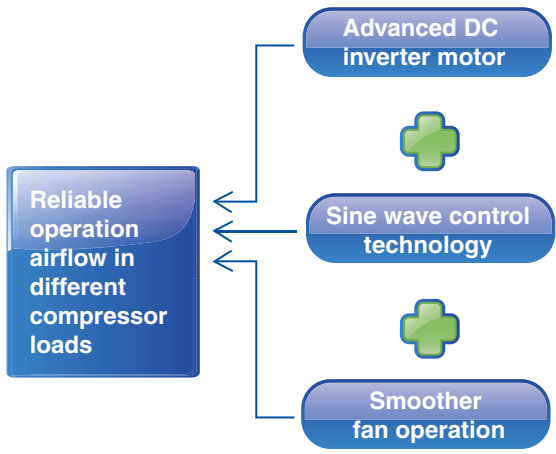

## Competitive Models

Unbalanced operating decreases fan's effectiveness and causes poor cooling performance.



## Mammoth

Fan distribution is more balanced to increase efficiency.

# High-Efficiency Energy Savings

## Temperature Controlled by Wired Controller with Higher Efficiency and More Energy Saving

Through setting temperature lower limit in cooling or dry mode, and setting temperature upper limit in heating, 3D heating or heat supply mode, the system is able to operate in a smaller temperature range so as to achieve energy saving.

### Soft Start Means Smaller Impact to Power Grid

The startup frequency of the inverter compressor is gradually increased from 0Hz to the required operation level. Lower load torque means lower amp draw. Inverter compressors use less energy during start up than traditional compressors. The electromagnetic impact is also reduced. Since the locked rotor amps (LRA) are negligible, it reduces the stress placed on the power supply, as well, particularly in generator or alternative energy applications.

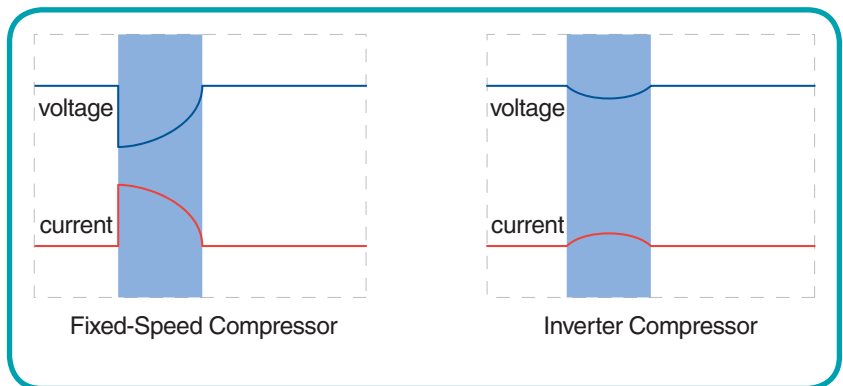

## Internal Components



Top-Discharge VRF Dual Compressor Motors



Top-Discharge VRF Single Compressor Motor

# Proven Reliability

## Rotation Operation Maximizes Life Span

When multiple units are combined, one unit will be the primary operating unit. As increased heating/cooling is required, additional units will be energized. After 8 hours of operation the system will automatically change the primary unit to another module. By spreading operating time over the different modules, the lifespan of the entire system is increased.



Through 10 years of research and development every component has been improved including electrical components, mechanical parts, controls and communications technology.

## Two-Stage Oil Separation Control Technology

The first stage will separate 98% of the oil from the refrigerant. The second stage will remove 95% of the remaining oil. This results in an overall 99.9% removal rate. This results in 99.9% of the oil remaining in the outdoor unit, ensuring the compressor(s) are always properly lubricated.

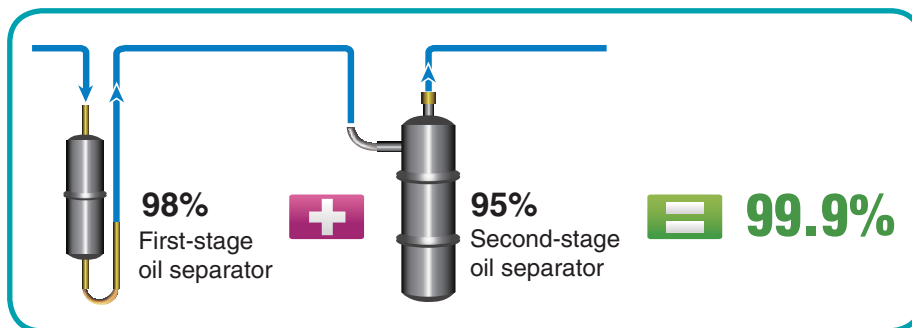

# Proven Reliability

## Oil Return Control

### New Oil Return Control

The system effectively controls system oil return and oil storage of each compressor greatly improving the life of the compressors.

For the 0.1% of oil that does make into the refrigerant piping and indoor units, after a certain amount of runtime at certain conditions, the system will perform its Oil Return function, returning the oil to the outdoor unit, where it belongs.

### Specialized Compressor Oil Storage Control

Specialized compressor storage control maintains a minimum amount of oil for compressor operation.

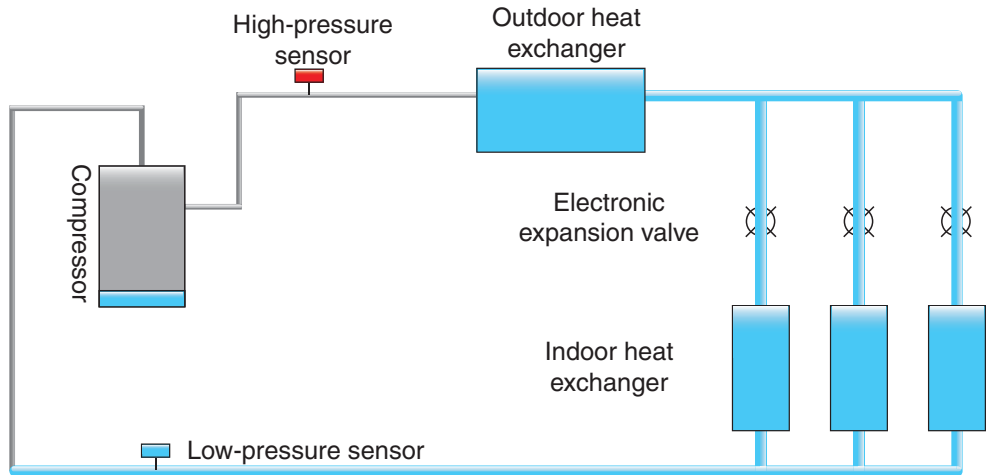

Oil storage status before oil return

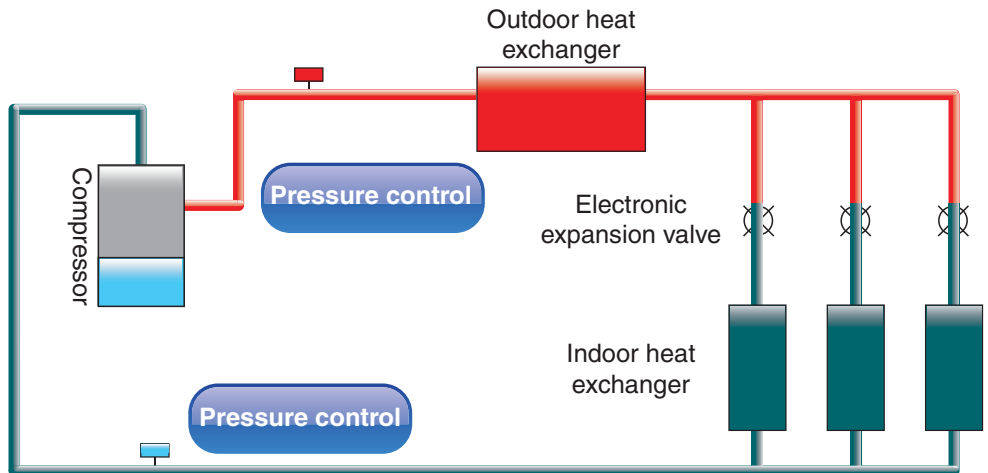

Oil return operation

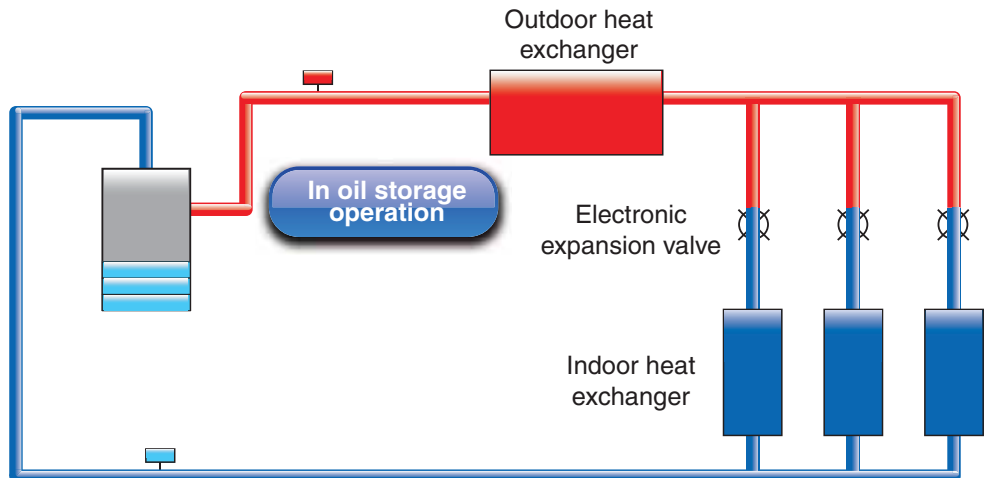

Oil storage operation



# Proven Reliability

## Oil Balance Control Technology

### Oil Balance Between Each Module

Based on the actual status of each module and compressor, the system can regulate compressor operation and maintain oil balance of each module.

### Oil Balance Between Each Compressor

Refrigerant is taken into the compressor by the suction pipe and then runs through the cooling system. It can control the oil level and minimum oil volume required by each compressor so as to maintain oil balance between each compressor.

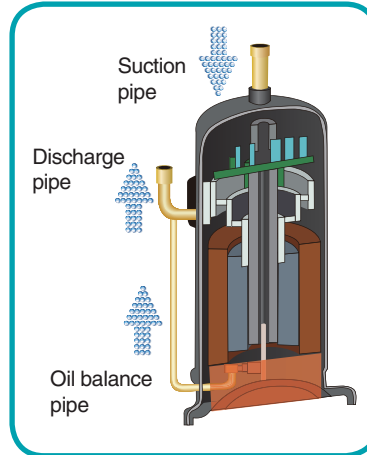
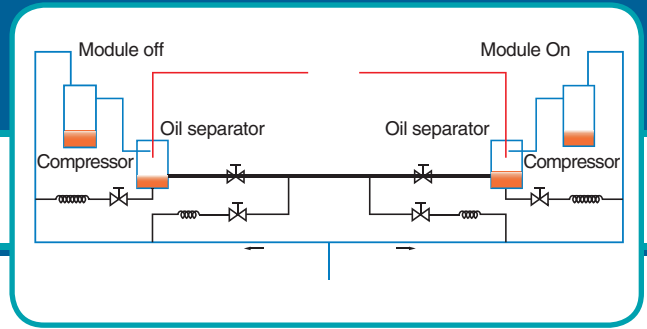

## Intelligent Detection Control

### Pressure Sensor Detection Control

The pressure sensor can precisely detect system high and low pressure. It will adjust fan and compressor operation to make sure the system operates at the most energy efficient pressure condition.

### Temperature Sensor Detection Control

Several temperature sensors detect the ambient temperature, indoor temperature and refrigerant evaporating temperature. From this information the unit will adjust to operate at optimum efficiency.

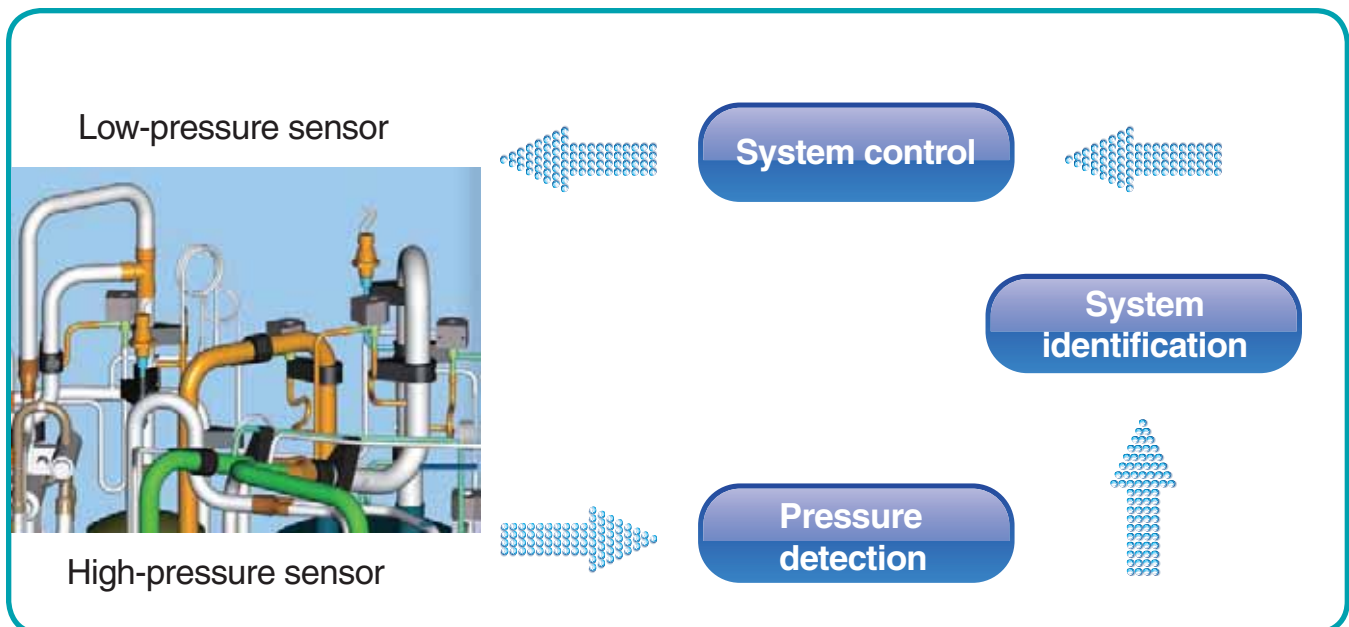

# Proven Reliability

## Multi Electronic Expansion Valve Control

Outdoor electronic expansion valves (EXV) not only have throttling effect, but also control refrigerant flow. The system adopts multi-electronic expansion valves control with a total of 960 grades regulated by two EXVs. This regulates the refrigerant flow precisely and ensures reliable operation.

The outdoor units have two Electronic Expansion Valves (EEV's). One is used during heating operation to regulate the refrigerant flow to the outdoor coil (evaporator in heat mode). The other EEV is used during cooling operation to regulate the floor to the subcooling circuit in the outdoor unit. The EEV's have 480 steps of control.

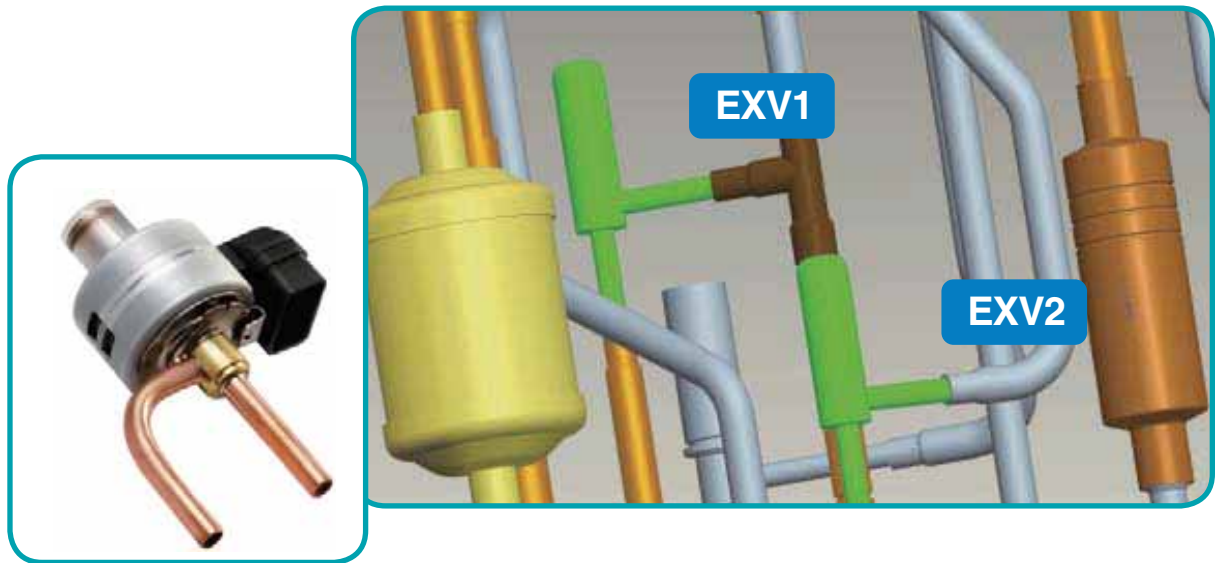

## Anticorrosive Golden Fins

The aluminum-manganese, anti-rust alloy fins are coated with an epoxy resin. This increases the anticorrosive performance in salt spray testing by 200%-300%.

Hydrophilic Layer

Golden Protection Layer  
(Epoxy Resin & Modified Acrylic)

Aluminum-Manganese  
Anti-Corrosive Alloy

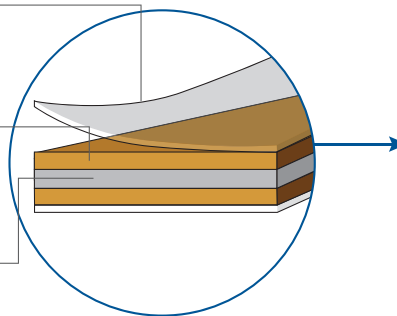

# Proven Reliability

## Prioritization of Emergency Operation

Mammoth outdoor units can sense when electrical power supply is interrupted and a backup generator is engaged. The units can be set to continue to operate under low-voltage conditions. Priority can be assigned to certain spaces and the system will continue to operate at the highest capacity it can.

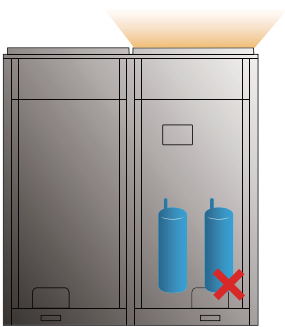
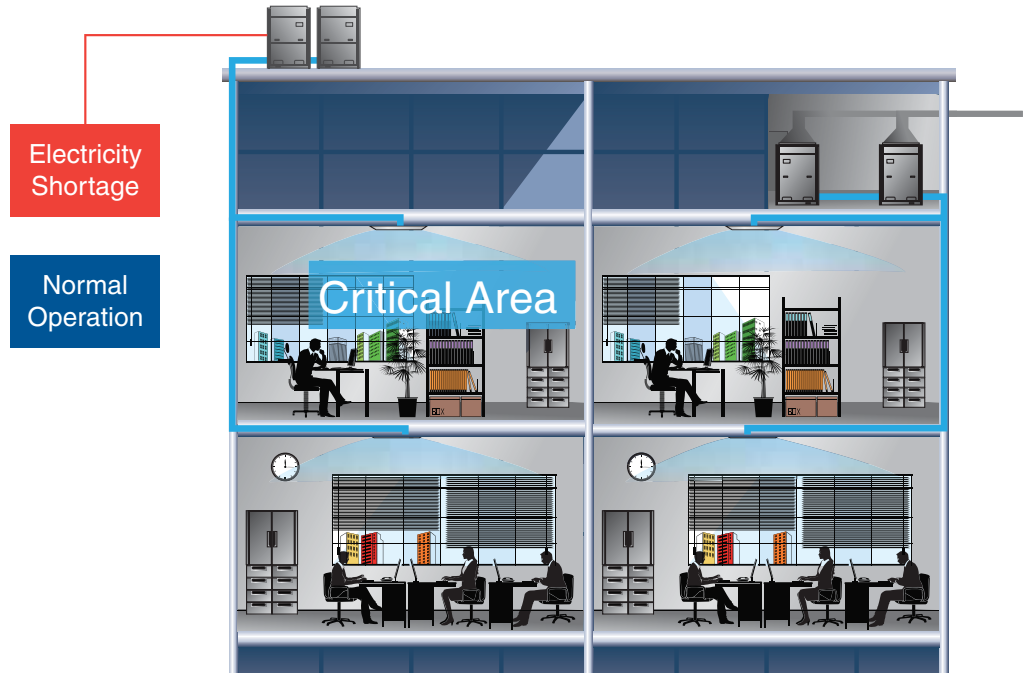

## Emergency Operation

When a single unit of a multi-module system is damaged, the other units will perform at emergency operating levels as needed to sustain the building load.

Likewise, when a single compressor in a single unit fails, the others will perform at increased levels.

In dual fan units, a single fan can continue to operate if the other fails.

An error code will be displayed to let the building occupants know that there is a problem but the units will continue to operate, depending on the failure.

# Easy Maintenance and Service

## Auto Refrigerant Recovery

During maintenance auto refrigerant recovery function is set and shutoff valve is closed. The compressor, EXV, solenoid valve and fan, etc. will automatically operate. To be environmentally friendly, the refrigerant is captured at the condensing side of the outdoor unit. The system low pressure signal will be displayed.

VRF units feature both “pump-down” and “pump-out” operations for easy maintenance. Pump-down is used for maintenance or repair on the indoor-side of the system, while pump-out is used for maintenance or repair of the outdoor unit.

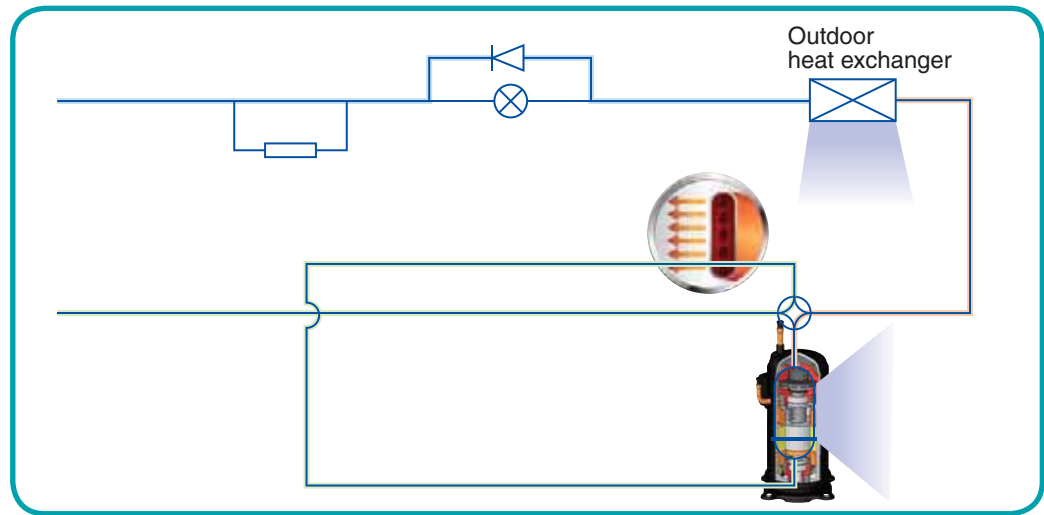

## Inspection Window

For quick inspection of system operation an inspection window is available, saving time and the effort required to remove the front panel.

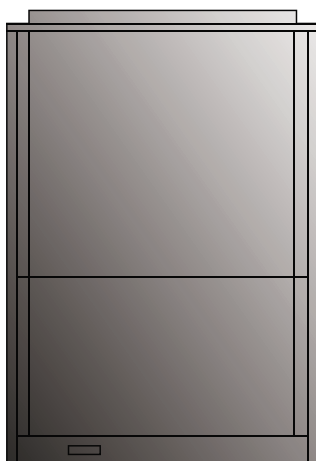

Competitive Models

**VS**



Inspection window

# V5 Outdoor Units

## V5 Outdoor Unit Nomenclature



**R-410A**

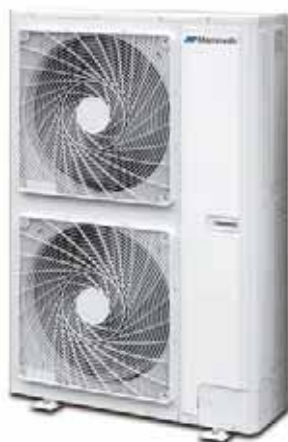
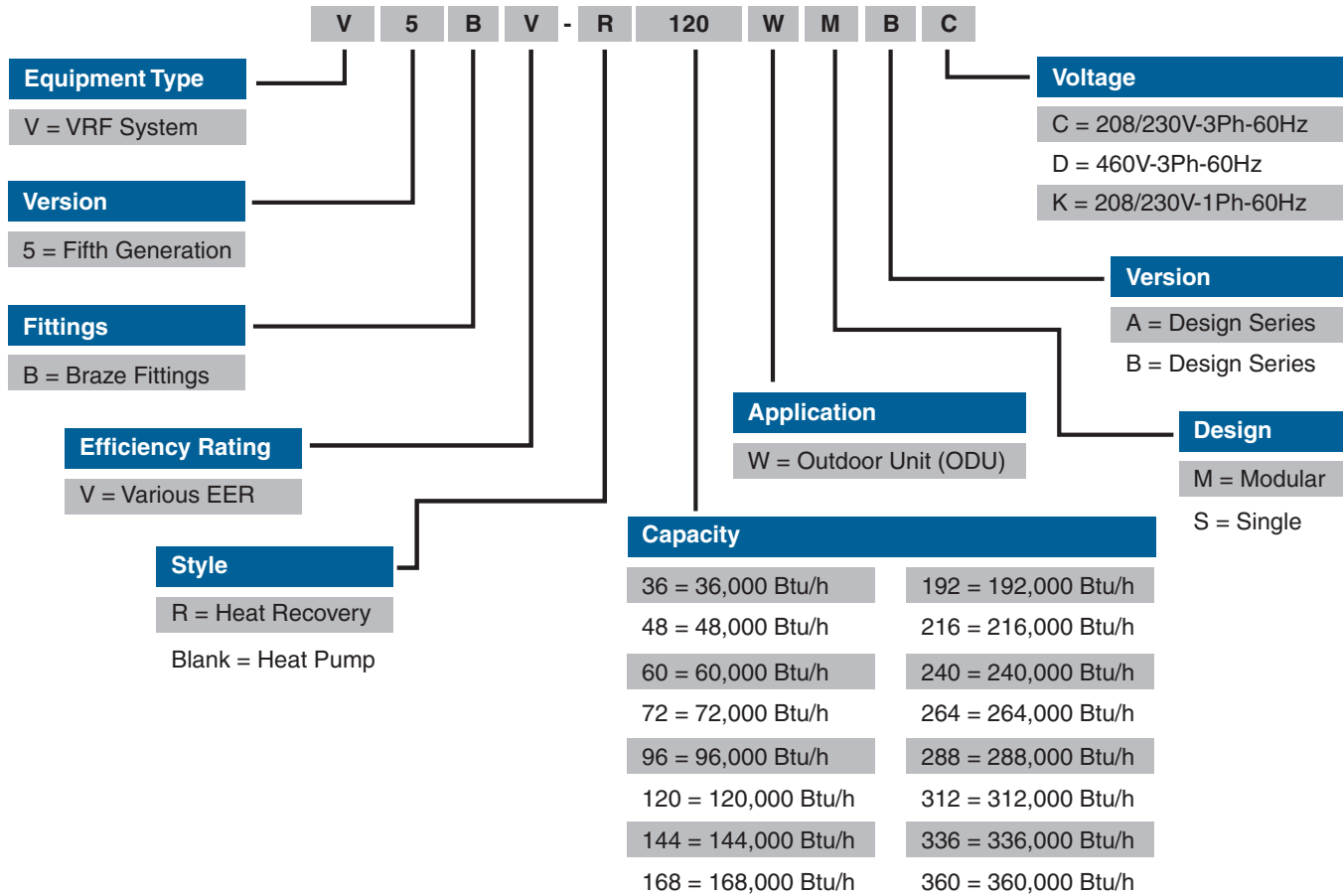

V5 Mini Heat Pump  
3, 4 & 5 Ton



V5 Heat Pump  
6, 8 & 10 Ton



V5 Heat Recovery  
6, 8 & 10 Ton

# V5 Mini Heat Pumps

## Residential/Light Commercial Multi-Zone Systems

Mammoth VRF Mini multi-zone systems offer condensers in 3, 4 and 5 tons. These are stand-alone condensers that can be combined with a minimum of 1 and up to 9 indoor units. The minimum and maximum number of indoor units is determined by the system's connectable capacity. The connectable capacity range for heat pump systems is 50% to 135% of the capacity rating of the outdoor unit. The collective capacity rating of indoor units must fall within the connectable capacity range for the system to function correctly.

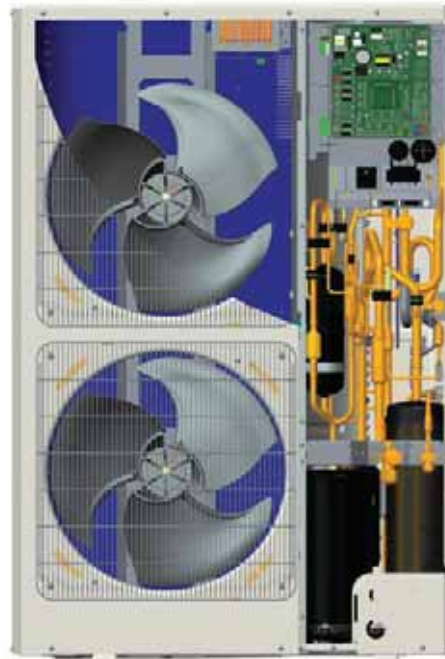

V5 Mini Internal Components

## Efficiency - Reduced Energy Usage Saves Money

### All DC Inverter Compressor

This Mini VRF System uses inverter compressor technology. By changing the displacement of compressor, stepless capacity regulation within range of 10%~100% can be realized. Various models are provided with capacity range from 3 to 5 tons (nominal), which can be widely used in residential, commercial and working area and especially applicable to places with big load change.



# V5 Mini Heat Pumps

## Wired Controller Allows for Higher Efficiency and Energy Savings

By setting temperature lower limit in cooling or dry mode, and setting temperature upper limit in one of three available heat modes, the system is able to operate in a narrower temperature range to achieve greater energy savings.



## Sensorless DC Inverter Fan Motor

The indoor unit has a high-efficiency brushless DC motor, which is 30% more efficient compared to conventional motors.

Emulation software in the logic of the indoor unit maximizes the efficiency of the evaporator.

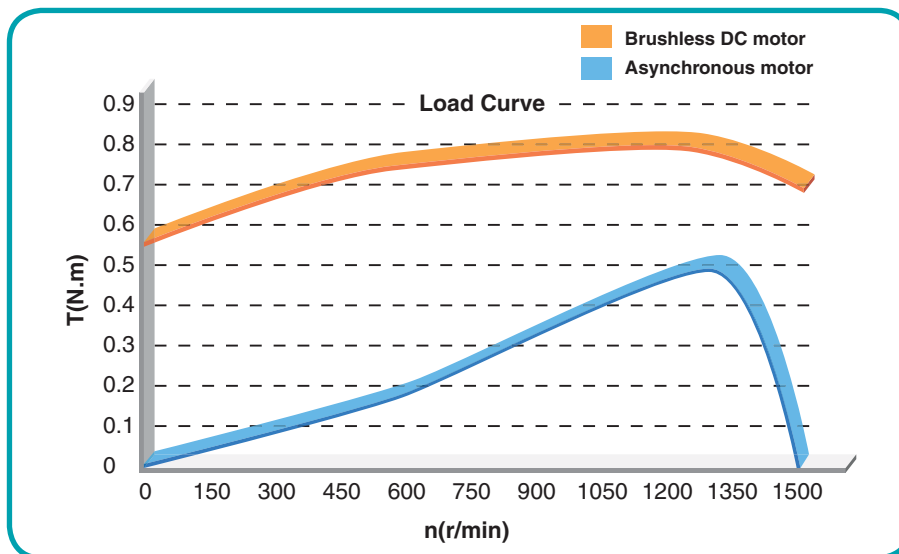

## High-efficiency Digital PFC Control\*

High-efficiency Power Factor Correction (PFC) control technology improves efficiency by about 1% compared with conventional PFC. For the air conditioner with rated power of 18,000 BTU, 50W of electricity can be saved every hour and 1,200W of electricity can be saved every day.

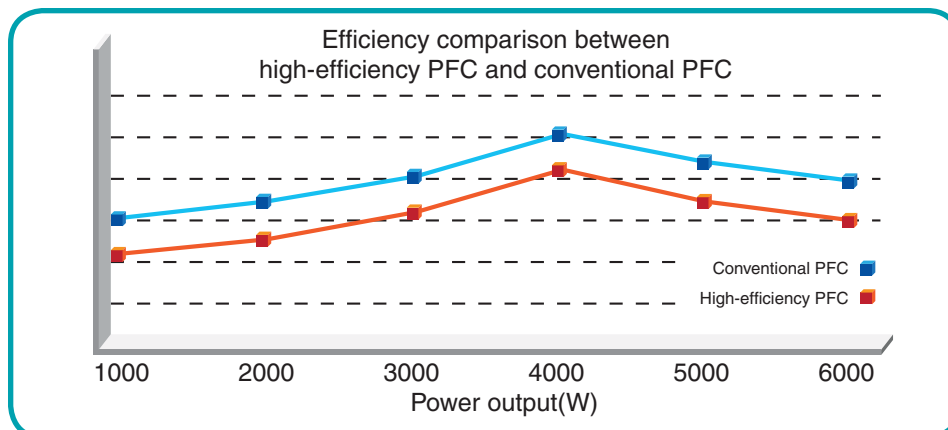



\* This feature is applicable for V5 Mini outdoor units only.



# V5 Mini Heat Pumps

## Wider Operation Range in Cooling Mode

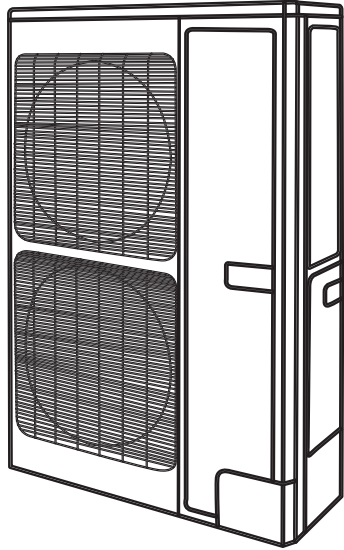
The DC motor has more accurate high pressure control, which effectively solves the high pressure control problem in low ambient temperature cooling.

	
<p>Competitive Models</p>	<p>Mammoth Mini</p>
<p>Cooling: 50~120°F (10~48°C) Heating: -4~80°F (-20~27°C)</p>	<p>Cooling: 23~120°F (-5~48°C) Heating: -4~80°F (-20~27°C)</p>

## Compressor Closed-loop Startup Technology Provides More Reliable Startup

The closed-loop startup control technology means less current is required, and startup is more reliable. (Applies to V5 Mini outdoor units only)

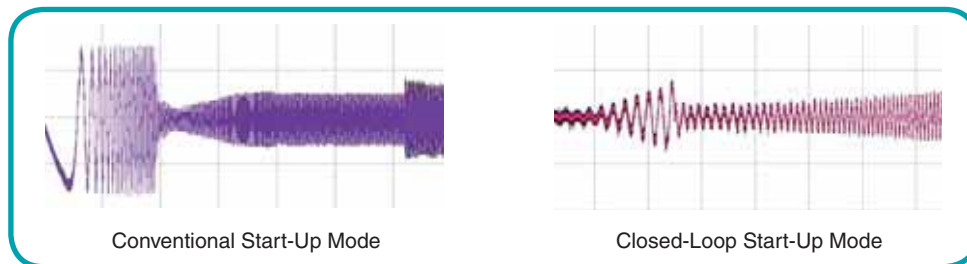



# V5 Mini Heat Pumps

## High Anti-Interference Ability

The latest CAN bus technology uses non-polar communication with high anti-interference prevention. Common communication wire can meet the communication demand with no need of specialized shielding.

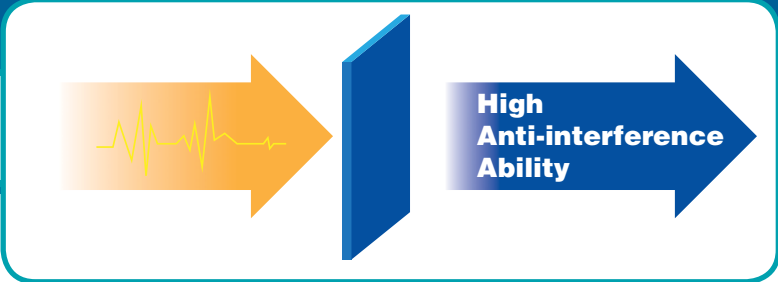

## Intelligent Temperature Control

Intelligent temperature control technology is used for super fast heating/cooling.



# V5 Mini Heat Pumps

## Quiet Outdoor Unit

The advanced sub-cooling control reduces the liquid flow noise of indoor unit in cooling operation.

The sound of the outdoor unit can be as low as 45dB thanks to sound optimized design of the fan and compressor system. There are several quiet mode settings.



## Quiet Indoor Unit

The patented centrifugal fan and fan casing reduce sound level by as much as 22dB(A).

The entire fan assembly was designed so that it is placed at the optimum angle. Also the ratio between the internal and external diameters allow for the maximum amount of airflow at minimum sound levels.

The advanced supercooling control and oil-return technology (in heating mode) combine to provide a quieter flow of liquid to the indoor unit.

When comparing decibel levels of competitive equipment, remember that an increase of 10dB can be perceived as twice as loud. This is especially important when comparing noise levels of refrigerant distribution boxes.

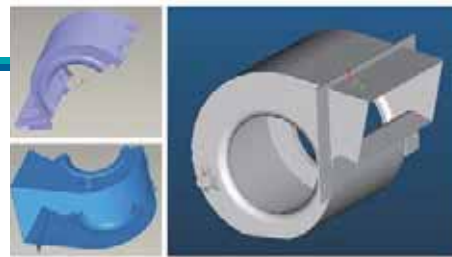

For comparison purposes, rustling leaves have a decibel level of 20. A whisper in a quiet library from 6 feet away has a decibel level of 30.

## Noise Levels - BC verses MEU

A difference of sound as little as 10dB can be perceived as being twice as loud. BC Controller Solenoid noise during mode change up to 56dB. Single Port BS Box during mode change as little as 35dB.



BC Controllers



BS Boxes

# V5 Mini Heat Pumps

## Non-Commutative Oil Return Technology in Heating

The unit can achieve non-commutative oil return in heating when outdoor ambient temperature is within 32~68°F (0~20°C). Thanks to this technology, indoor ambient temperature is more stable and comfort is improved in heating mode.

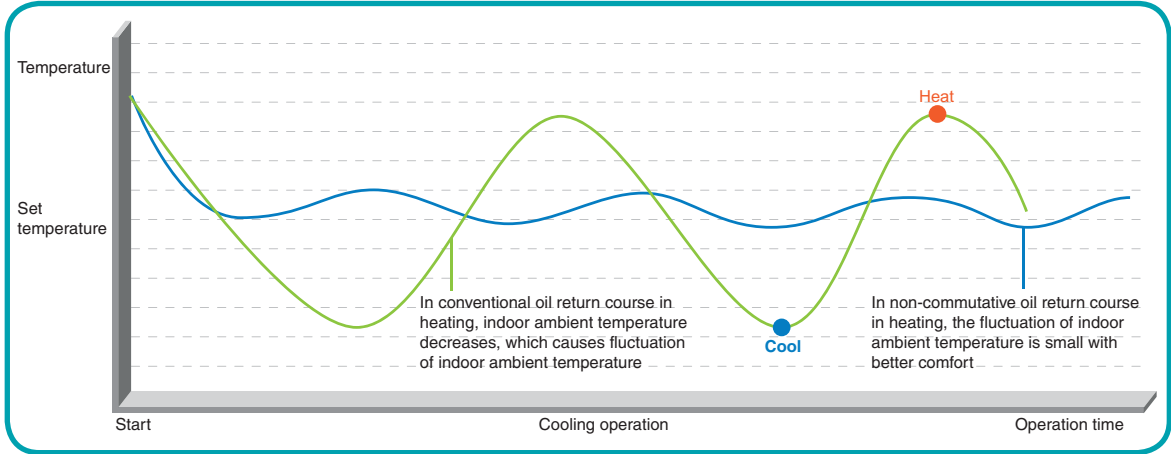

## V5 Mini Multi-Zone - 3, 4 and 5 Ton - 208-230V, 1 Phase - 60 Hz

Model		V5BV-36WMAK	V5BV-48WMAK	V5BV-60WMAK
Capacity Range	Tons	3	4	5
Capacity	Cooling	37.5	48	60
	Heating	42	54	66
SEER		16		
HSPF		9		8.2
Power Supply	Ph-V-Hz	1-208-230-60		
MCA	A	32	37	37.4
MOP	A	50	60	70
Maximum Number of Indoor Units	Unit	6	8	10
Refrigerant Charge Volume	oz	176.4		229.3
	kg	5.0		
Sound Pressure Level	dB(A)	55	56	58
Connecting Pipe	Liquid	inch	3/8	
		mm	9.52	
	Gas	inch	5/8	3/4
		mm	15.87	19.05
Outline Dimension	WxDxH	inch	35-3/8 x 13-3/8 x 53	
		mm	900 x 340 x 1345	
Package Dimension	WxDxH	inch	39-1/4 x 18 x 59-5/8	
		mm	998 x 458 x 1515	
Net Weight/Gross Weight	lb	243/265		274/300
	kg	110/120		124/136

Note: No Branching Boxes needed.

## V5 Heat Pump Outdoor Units

### Commercial Multi-Zone Systems

Mammoth VRF heat pump condensers are available in 6, 8 and 10 tons. These base model condensers can also be combined to make systems with capacities ranging from 12 all the way up to 30 tons. Combinations above ten tons are only available in heat pump systems. Indoor unit combinations range from 13 indoor units all the way up to 36 indoor units. The minimum and maximum number of indoor units is determined by the system's connectable capacity. The connectable capacity range for heat pump systems is 50% to 135% of the capacity rating of the outdoor unit. The collective capacity rating of indoor units must fall within the connectable capacity range. Over or under and the system won't work at all.



Single Top-Discharge  
VRF Condenser  
Cutaway View



# V5 Heat Pump Outdoor Units



## V5 Heat Pump - 6, 8 and 10 Ton - 208/230V, 60 Hz, 3 Phase

Model			V5BV-72WMBC	V5BV-96WMBC	V5BV-120WMBC
Capacity Range		Tons	6	8	10
Capacity	Cooling	MBtu/h	69.0	92.0	114.0
	Heating	MBtu/h	77.0	103.0	129.0
EER			13.7	13.2	12.4
IEER*			28.1	26.6	25.2
COP			4.22	4.15	3.95
Airflow Volume		CFM	6080	8230	
Power Supply		Ph-V-Hz	3-208/230-60		
MCA		A	30	45	74
MOP		A	45	70	100
Maximum Drive IDU Number		unit	13	16	19
Refrigerant Charge Volume		kg	6.5	11.2	11.8
		oz	229.3	395.1	416.2
Sound Pressure Level		dB(A)	60	61	63
Connecting Pipe	Liquid	inch	3/8		1/2
	Gas	inch	3/4	7/8	1-1/8
	Oil Balance	inch	3/8		
Dimension (WxDxH)	Outline	inch	36-3/5 x 30-1/8 x 63-1/5	52-3/4 x 30-1/8 x 63-1/5	
	Package	inch	39-3/4 x 33 x 69-7/8	56 x 33 x 69-7/8	
Net Weight/Gross Weight		lbs	496/518	661/694	794/827

\* Non-Ducted Indoor Units

# V5 Heat Pump Outdoor Units

## Dimension, Weight, Connection Line and Indoor Unit Matching Matrix

Mammoth VRF condensers are available in 6, 8 and 10 Tons. These base model condensers can also be combined to make systems with capacities ranging from 12 all the way up to 20 (30 Tons Heat Pump systems only). By combining the three base sizes, you can create a system to provide up to 240K BTU of heating.

Cooling Capacity Need		Heating Capacity Need	Combine Unit Sizes			Dimensions						Weight		Connecting Pipe Diameter				Oil Balance Pipe Diameter	Maximum IDUs	
			72	96	120	Millimeters			Inches					Liquid Line		Vapor Line				
MBTU/H	Tons	MBTU/H				W*	D	H	W	D	H	kg	lb	mm	in	mm	in	mm	in	
144	12	162	2			1340	765	1605	52 3/4	30 1/8	63 1/4	360	794	12.7	1/2	25.4	1	9.52	3/8	23
168	14	189	1	1		1340	765	1605	52 3/4	30 1/8	63 1/4	360	794	12.7	1/2	28.5	1 1/8	9.52	3/8	26
192	16	216			2	2060	765	1605	81 1/8	30 1/8	63 1/4	450	992	15.9	5/8	28.6	1 1/8	9.52	3/8	29
216	18	243			1	2060	765	1605	81 1/8	30 1/8	63 1/4	450	992	15.9	5/8	28.6	1 1/8	9.52	3/8	33
240	20	270			2	2470	765	1605	97 1/4	30 1/8	63 1/4	510	1124	15.9	5/8	28.6	1 1/8	9.52	3/8	36

Note: Some combinations pending approvals. Please check AHRI directory for approved combinations.

\* Width of multiple units includes clearance of 200mm (7-7/8") between units.



# V5 Heat Recovery System

## Commercial Multi-Zone Systems

Mammoth VRF heat recovery condensers are available in 6, 8 and 10 Tons. Indoor unit combinations range from 12 indoor units all the way up to 20 indoor units. The minimum and maximum number of indoor units is determined by the system's connectable capacity. The connectable capacity range for heat recovery is 50% to 135% of the capacity rating of the outdoor unit. The collective capacity rating of indoor units must fall within the connectable capacity range. Over or under and the system won't work at all.



## High-Efficiency

The Heat Recovery System has all the benefits of DC inverter technology,

- DC fan linkage control
- Precise control of capacity output
- Balancing control of refrigerant
- Oil balancing technology with high pressure chamber
- High-efficiency output control
- Low-temperature operation control
- Super heating
- High adaptability for unique applications
- Environmental refrigerant

Its energy efficiency is improved by 78% compared with conventional multiple VRF units.

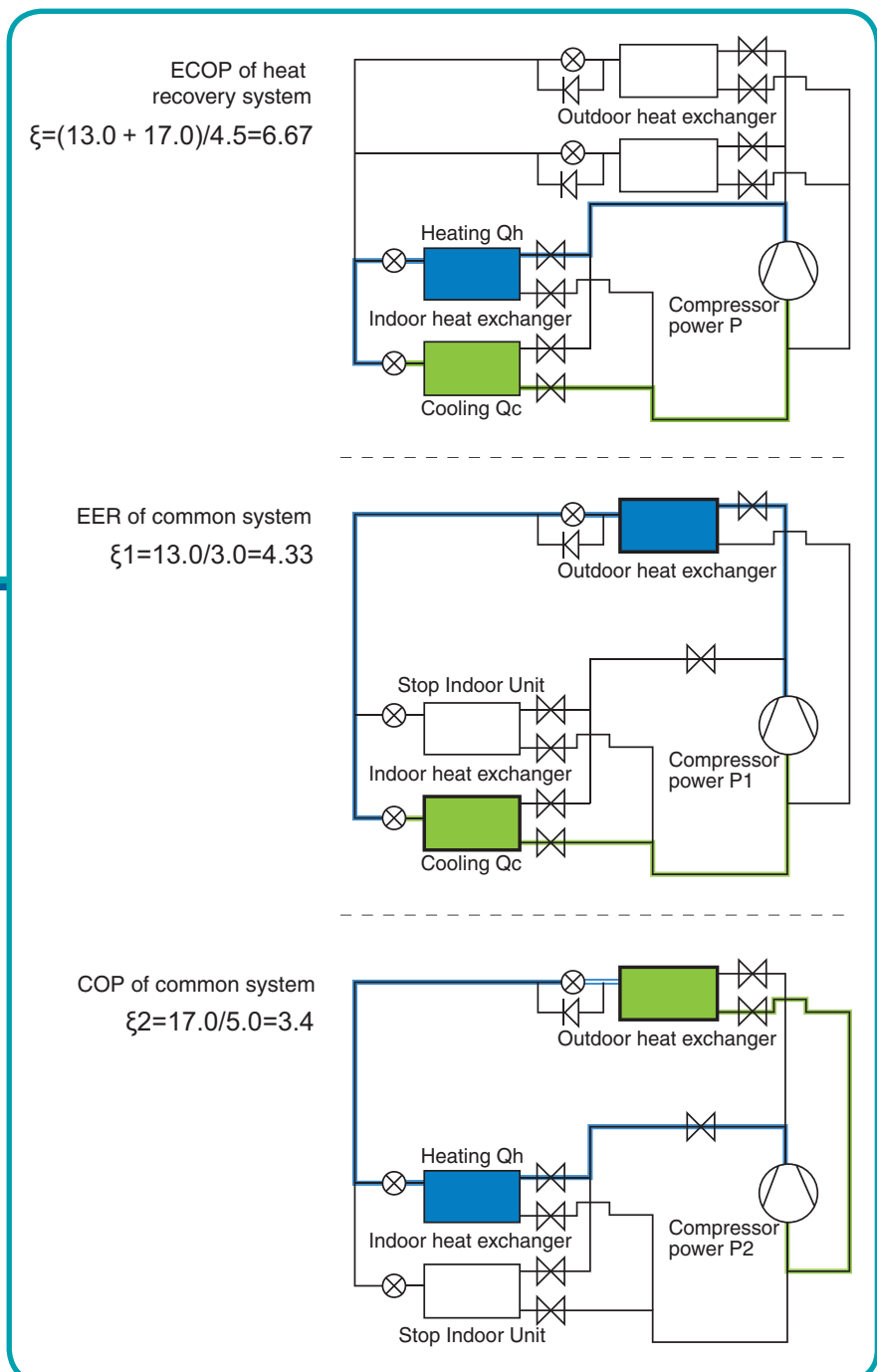

# V5 Heat Recovery Outdoor Units

Commercial Multi-Zone - 6, 8 and 10 Ton - 208/230V, 60 Hz, 3 Phase

Model			V5BV-R72WMBC	V5BV-R96WMBC	V5BV-R120WMBC
Capacity Range		Tons	6	8	10
Capacity	Cooling	MBtu/h	67.0	90.0	111.0
	Heating	MBtu/h	75.0	100.0	126.0
EER			12.0	11.2	11.5
IEER			25.0	23.5	24.0
COP			3.53	3.50	3.50
SCHE			28.0	27.5	27.0
Airflow Volume		CFM	8240		
Power Supply		Ph-V-Hz	3-208/230-60		
MCA		A	35	39	74
MOP		A	50	60	100
Maximum Connected IDU Quantity		unit	12	16	20
Refrigerant Charge Volume		oz	338.6	395.1	416.2
Sound Pressure Level		dB(A)	61	61	63
Connecting Pipe	Liquid	inch	3/8	3/8	1/2
	Gas (Low Pressure)	inch	3/4	7/8	1 1/8
	Gas (High Pressure)	inch	5/8	3/4	
Dimension (WxDxH)	Outline	inch	52-3/4 x 30-1/8 x 63-1/5		
	Package	inch	56 x 33 x 69-7/8		
Net Weight/Gross Weight		lbs	666/699	683/716	794/827



# V5 Heat Recovery System

When the cooling capacity and heating capacity of common system are equivalent to the capacity of a heat recovery system, its energy efficiency ratio is:

$$2=(13.0+17.0)/(3.0+5.0) = 30.0/8.0 = 3.75$$

The energy efficiency ratio of a heat recovery system is higher than a common system or common systems:

$$(6.67-3.75) \times 100\% / 3.75 = 78\%$$

Note: Working conditions of above-mentioned test: outdoor temperature 45°F/43°F (7°C/6°C), indoor temperature in cooling 81°F/66°F (27°C/19°C), indoor temperature in heating 68°F/59°F (20°C/15°C).

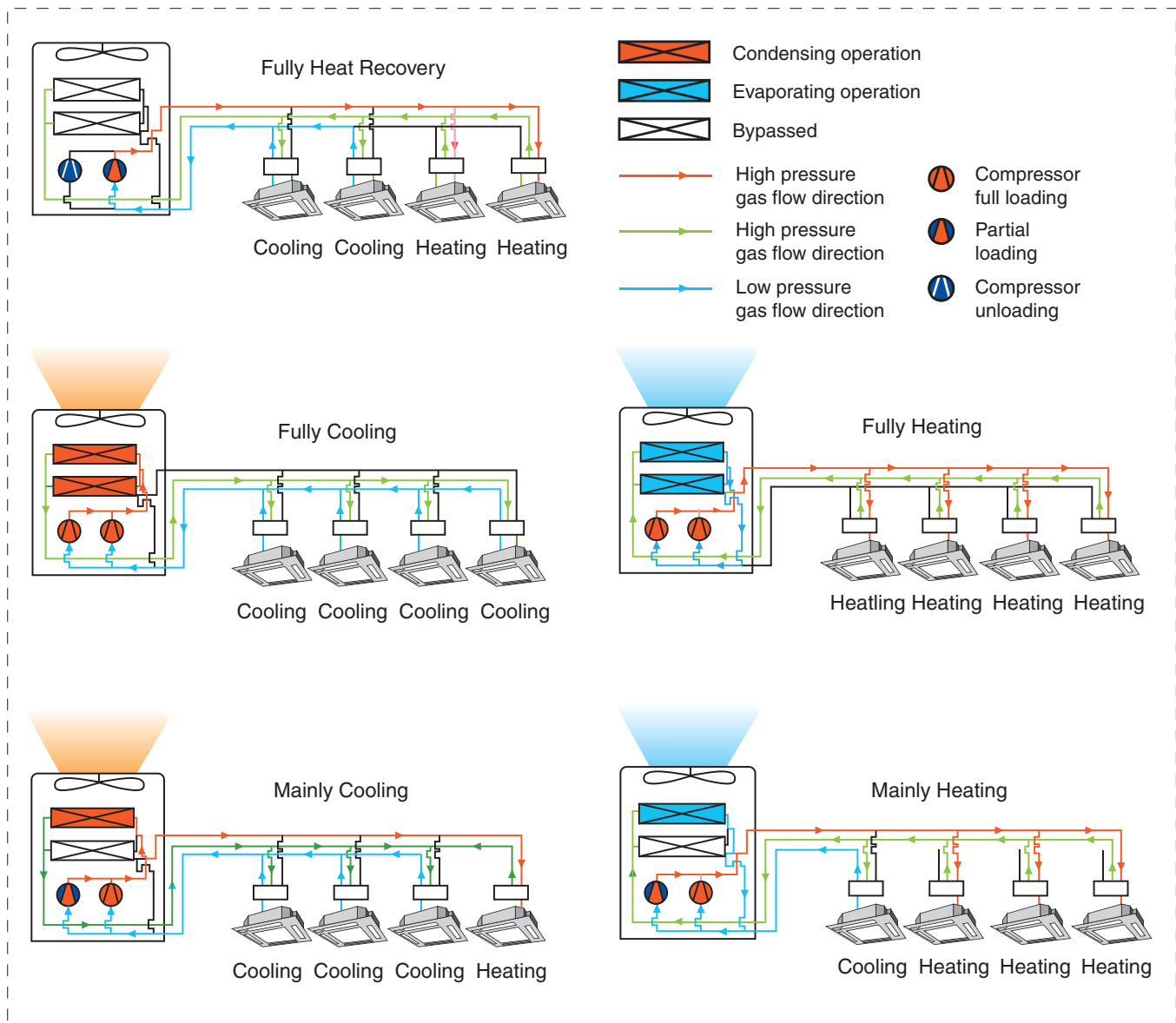

# V5 Heat Recovery System

## Individual Control for More Energy Savings

The set temperature of each room may vary by the individual thermostat control of each indoor unit.

The cooling and heating operation can be performed simultaneously.

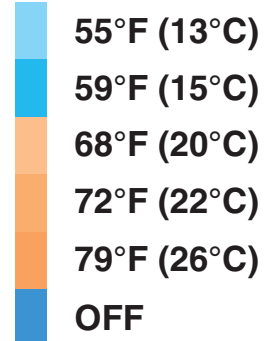

## Intelligent Quiet Function at Night

The Night Quiet function adjusts the overall capacity of the outdoor unit, reducing the overall noise by 8dB(A), reducing noise production to as low as 50dB(A) at night. For example, when most occupants are returning home from work in the evening, they adjust their thermostats, sometimes by many degrees. This will cause other VRF systems to ramp up to 100% immediately, producing a large amount of noise. This function prevents a sudden increase, therefore reducing noise.

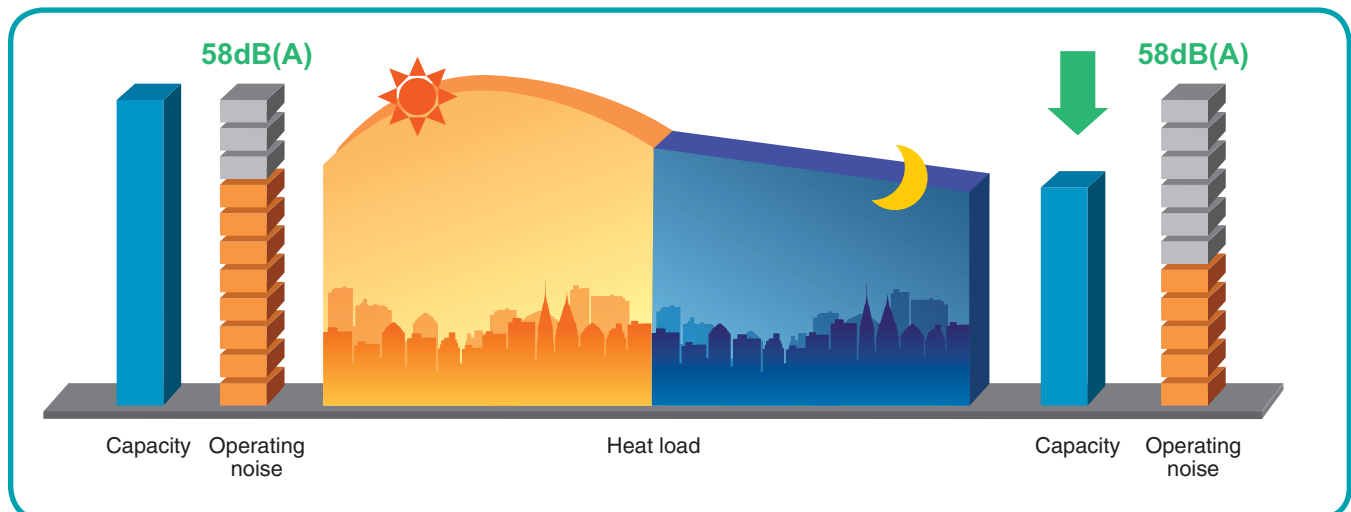

# V5 Heat Recovery System

## Low Noise Design

High-side shell compressor has lower exhaust pressure fluctuation so sound is significantly reduced.

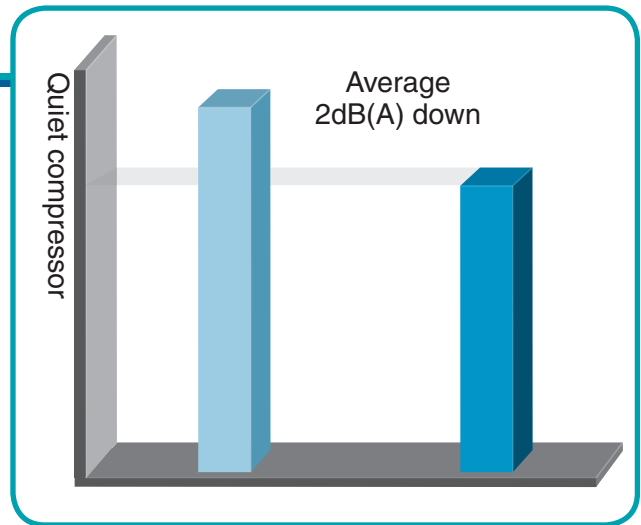

The optimized design of the condensing fan blade reduces the airflow turbulence through the blades. Lower turbulence means quieter operation.

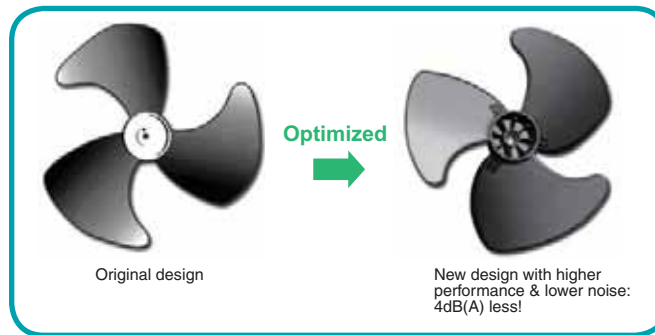

## Wide Operating Range

The unit can operate in a wide range of ambient temperatures.

Note: If the total capacity of indoor units is 50% lower than outdoor unit, cooling range drops to 5°F (-15°C). If the total capacity of indoor units is 50% higher than outdoor unit, cooling range raises to 23°F (-5°C).

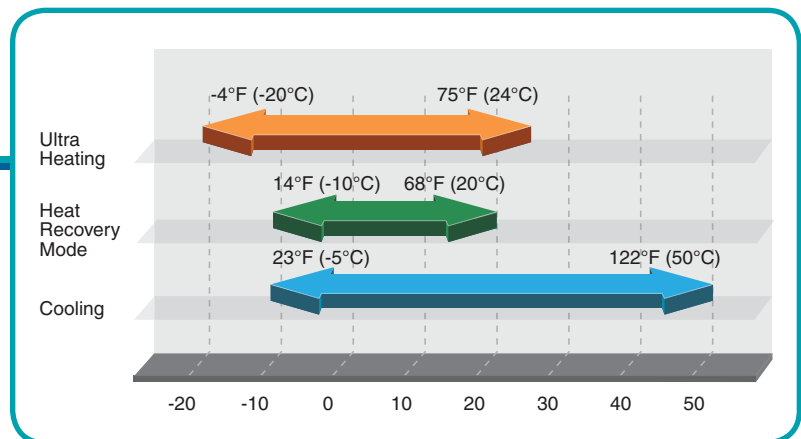

# V5 Heat Recovery System

## No External Oil-Balanced Design

The heat recovery units don't require an external oil-balance pipe, reducing system pipe connections for easier installation. The system will allocate lubricating oil to each module according to its demand, for a more intelligent, more efficient and more equal distribution.

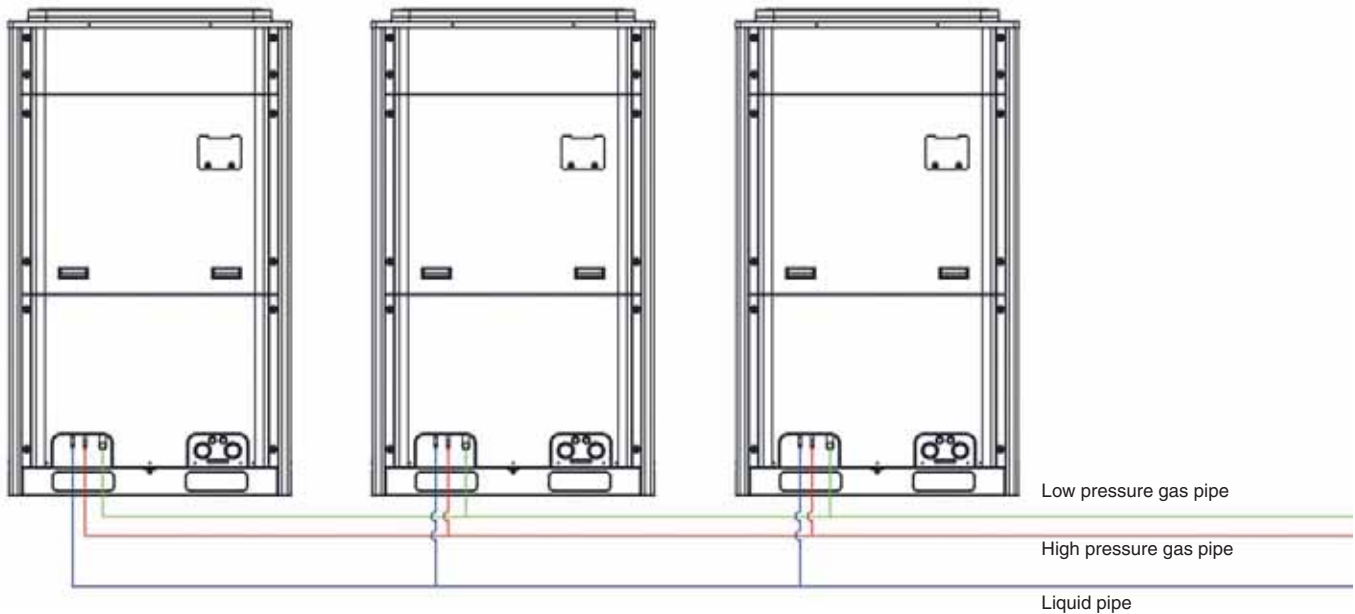

## 5-Way Piping Connection

Piping and wiring connections can be made to the front, back, left, or right side of the unit or to the bottom.

The 5-way piping connection makes installation easier resulting in lower installation cost.



# V5 Branching Units

## VRF Mode Exchange Units



Model		V5BV-R1K	V5BV-R2K	V5BV-R4K
Maximum Indoor Units	Unit	1	2	4
Number of Connectable Indoor Unit of each Port	Unit	8	8	8
Total Connectable Indoor Unit	Unit	8	16	32
Maximum Capacity of each Port	MBTUH	47		
Maximum Capacity of Connectable Indoor Unit	MBTUH	47	95	153
Power Supply	Ph/V/Hz	1-208/230-60		
MOP	A	15		
Outdoor Unit Piping Connection	Liquid	inch	3/8	
	Gas (Low Pressure)	inch	7/8	
	Gas (High Pressure)	inch	5/8	3/4
Indoor Unit Piping Connection	Liquid	inch	3/8	
	Gas	inch	5/8	

## Mode Exchange Unit (MEU)

Connects before each indoor unit, performs the function of real-time operation mode exchanging (cooling to heating, heating to cooling).

All MEU's contain the same Control boards, reducing the need for stocking multiple replacement boards.

Multi-port boxes have inlet and outlet connections, no Y-branches are needed to connect these MEU's.

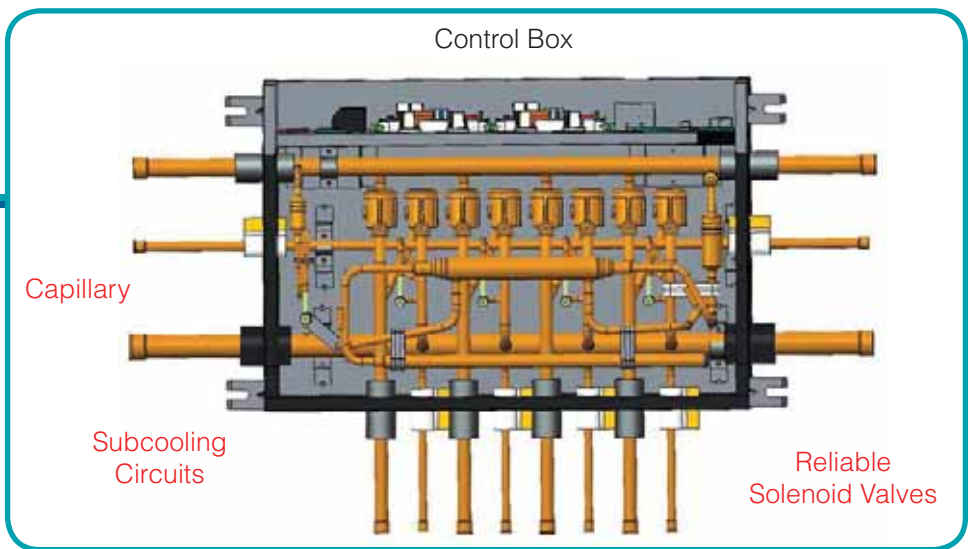

Internal Structure 1 to 4 MEU

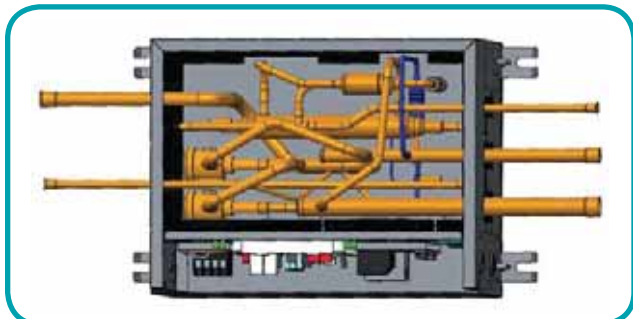

Internal Structure 1 to 1 MEU

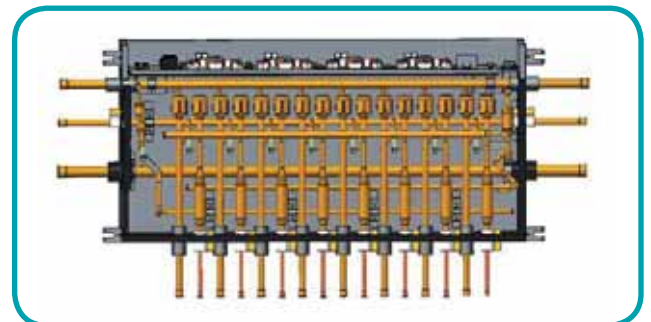

Internal Structure 1 to 8 MEU



## V5 Indoor Units



### Ducted Type, Cassettes, Wall Hung, Floor Ceiling and Console Type Units

Mammoth indoor units provide high efficiency and tremendous energy savings. These commercial grade inverter fan coils incorporate the most advanced heating and cooling technology available in the industry today. Inverter technology provides soft starting with super quiet operation and superior comfort over traditional air conditioning systems. These indoor units can be mixed and matched in thousands of combination to meet all load, air distribution, comfort, and décor demands.

### V5 Indoor Units - 7K to 96K BTU

Capacity Range (Approximately Btuh)	7,000	9,000	12,000	14,000
Ducted Low ESP	BDDL-2.2(07)SAK	BDDL-2.8(09)SAK	BDDL-3.6(12)SAK	–
Wall Mounted	B-HW-2.2(07)-A3AK	B-HW-2.8(09)-A3AK	B-HW-3.6(12)-A3AK	BDDL-4.1(14)SAK
Floor Ceiling	–	BDFC-2.8(09)-AK	BDFC-3.6(12)-AK	–
4-Way Cassette	BD4W-2.2(07)SAK	BD4W-2.8(09)SAK	BD4W-3.6(12)SAK	–
Compact 4-Way Cassette	–	BD4W-2.8(09)SBV	BD4W-3.6(12)SBV	–
2-Way Cassette	–	BD2W-2.8(09)SAK	BD2W-3.6(12)SAK	–
Console	BDCO-2.2(07)-AK	BDCO-2.8(09)-AK	BDCO-3.6(12)-AK	–

Capacity Range (Approximately Btuh)	15,000	18,000	21,000	24,000
Ducted High ESP	–	BDDH-5.6(18)SAK	–	BDDH-7.1(24)SAK
Ducted Low ESP	–	BDDL-5.6(18)SAK	BDDL-6.3(22)SAK	BDDL-7.1(24)SAK
Wall Mounted	–	B-HW-5.6(18)-A3AK	–	B-HW-7.1(24)-A3AK
Floor Ceiling	–	BDFC-5.0(18)-AK	–	BDFC-7.1(24)-AK
4-Way Cassette	BD4W-4.5(15)SAK	BD4W-5.6(18)SAK	BD4W-6.3(21)SAK	BD4W-7.1(24)SAK
Compact 4-Way Cassette	BD4W-4.5(15)SBV	BD4W-5.0(17)SBV	–	–
2-Way Cassette	BD2W-4.5(15)SAK	BD2W-5.0(18)SAK	–	BD2W-7.1(24)SAK
Console	–	BDCO-5.0(18)-AK	–	–

## V5 Indoor Units

### V5 Indoor Units - 7K to 96K BTU (continued)

Capacity Range (Approximately Btuh)	27,000	30,000	34,000	36,000
Ducted High ESP	–	BDDH-9.0(30)SAK	–	BDDH-11.2(36)SAK
Ducted Low ESP	BDDL-8.0(27)SAK	BDDL-9.0(30)SAK	BDDL-10.0(34)SAK	BDDL-11.2(38)SAK
Wall Mounted	–	–	–	–
Floor Ceiling	–	BDFC-9.0(30)-AK	–	BDFC-11.2(36)-AK
4-Way Cassette	–	BD4W-9.0(30)SAK	–	BD4W-11.2(36)SAK

Capacity Range (Approximately Btuh)	42,000	48,000	54,000	72,000	96,000
Ducted High ESP	BDDH-12.5(42)SAK	BDDH-14.0(48)SAK	BDDH-16.0(54)SAK	–	–
Ducted Low ESP	BDDL-12.5(42)SAK	BDDL-14.0(48)SAK	–	–	–
Large Ducted	–	–	–	BDDH-22.4(72)-AK	BDDH-28.0(96)-AK
Floor Ceiling	BDFC-12.5(42)-AK	BDFC-14.0(48)-AK	–	–	–
4-Way Cassette	BD4W-12.5(42)SAK	BD4W-14.0(48)SAK	–	–	–

# V5 Indoor Units

## V5 Indoor Unit Nomenclature

**B - DL 4.5(15) S A K**

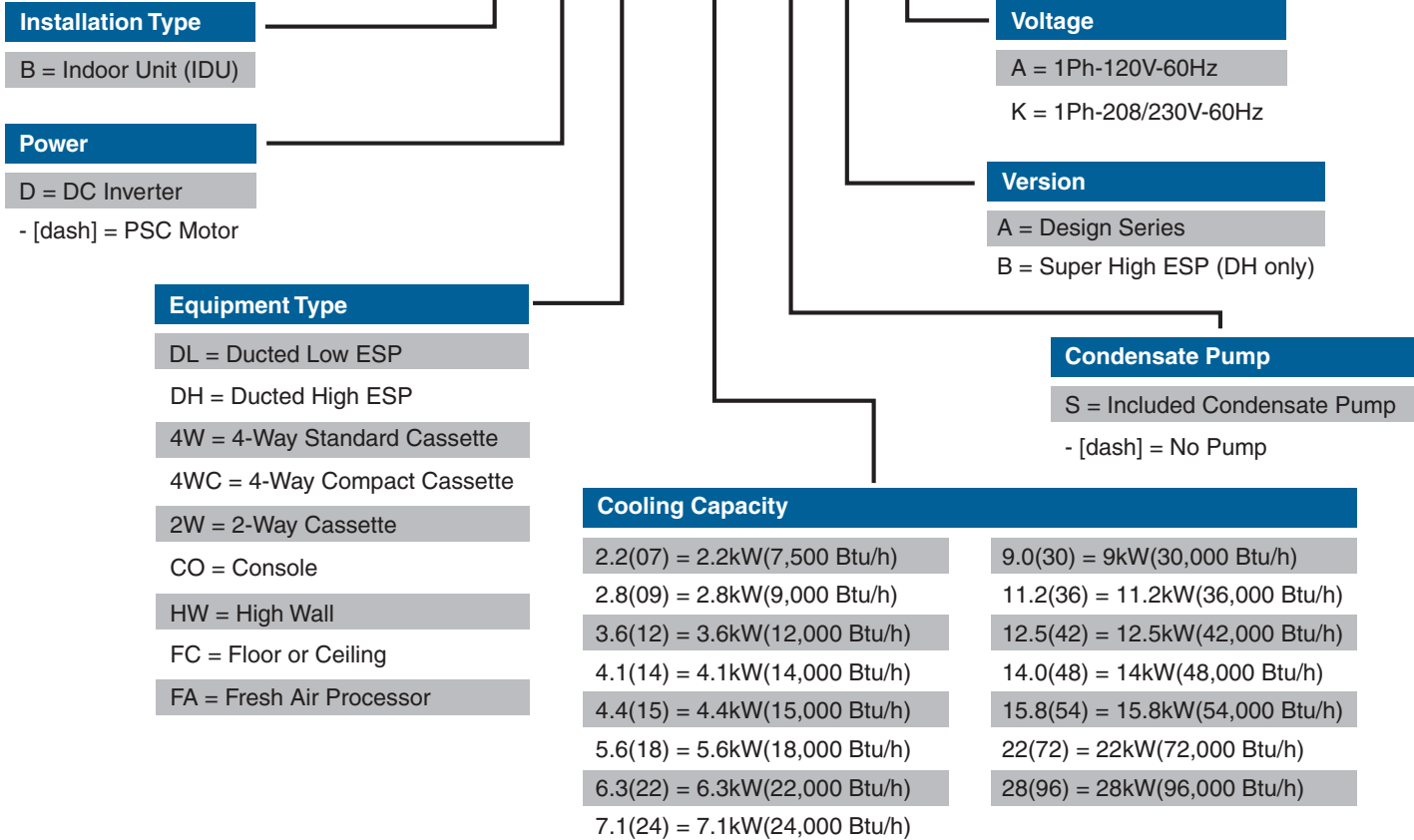

Ducted High ESP



Ducted Low ESP



2-Way Cassette



4-Way Compact Cassette

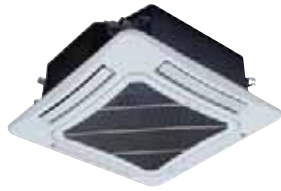

4-Way Cassette



Fresh Air Processor



Console



High Wall



Floor Ceiling





## High Static Pressure Ducted Type Indoor Units



### High Static Pressure Ducted Type Indoor Unit with Condensate Pump

#### High Static Pressure Design

Static pressure can be up to 150Pa, making it ideally suitable for buildings where long distance airflow is required.

#### Ease of Maintenance

The system has maintenance port for easy access maintenance, service and repair. Basic washable filters.

#### Intelligent Condensate Drain

Intelligent condensate drain pump can effectively drain up to 39 inches in height, saving space. Pump included in up to 54k Btu units.

#### Flexible Installation

This indoor unit can be installed with circular or rectangular air duct. Different styles of return air duct can also be selected based on building requirements.

#### Protection Function

The system monitors itself for:

- Freeze protection
- Fan motor overload
- Temperature sensor malfunction
- "Premium" Wired controller (WRC1) included

# High Static Pressure Ducted Type Indoor Units

18K to 96K BTU - 60 Hz

Model			BDDH-5.6(18)SAK	BDDH-7.1(24)SAK
Capacity	Cooling	MBtu/h	18.0	24.0
		kW	5.3	7.0
	Heating	MBtu/h	20.0	27.0
		kW	6.3	8.0
Power Supply		Ph-V-Hz	1-208~230-60	
Power Consumption		W	120	130
Airflow Volume (H/M/L)		M <sup>3</sup> /Hr	1000/800/600	1100/900/700
		CFM	590/471/355	650/530/410
Rated Current <sup>2</sup>	Cooling	A	0.6	
	Heating	A	0.6	
ESP		Pa (in. wc)	70/0~100 (0.28/0.40)	
Sound Level* (H/M/L)		dB(A)	44/40/36	45/41/37
Connecting Pipe Diameter	Liquid Line	in. (mm)	3/8 (9.52)	
	Suction Line	in. (mm)	5/8 (15.9)	
Drain Pipe	External Diameter	in. (mm)	1 (25.4)	
	Thickness	inch	3/32	
Outline Dimension	WxDxH	inch	50 x 22 x 10-1/2	
		mm	1271 x 558 x 268	
Package Dimension	WxDxH	inch	53-1/8 x 23-1/2 x 11-1/8	
		mm	1348 x 597 x 283	
Net Weight/Gross Weight		lb	77/88	
		kg	35/40	

Model			BDDH-9.0(30)SAK	BDDH-11.2(36)SAK	BDDH-12.5(42)SAK
Capacity	Cooling	MBtu/h	30.0	36.0	42.0
		kW	8.8	10.6	12.5
	Heating	MBtu/h	34.0	40.0	47.0
		kW	10.0	11.7	13.8
Power Supply		Ph-V-Hz	1-208~230-60		
Power Consumption		W	200	220	
Airflow Volume (H/M/L)		M <sup>3</sup> /Hr	1700/1450/1100	2000/1550/1200	
		CFM	1000/853/650	1175/912/706	
Rated Current <sup>2</sup>	Cooling	A	1.0		
	Heating	A	1.0		
ESP		Pa (in. wc)	70/0~100 (0.28/0.40)		
Sound Level* (H/M/L)		dB(A)	46/44/42	48/45/42	
Connecting Pipe Diameter	Liquid Line	in. (mm)	3/8 (9.52)		
	Suction Line	in. (mm)	5/8 (15.9)		
Drain Pipe	External Diameter	in. (mm)	1 (25.4)		
	Thickness	inch	3/32		
Outline Dimension	WxDxH	inch	48-3/8 x 30-1/2 x 11-3/8		
		mm	1229 x 775 x 290		
Package Dimension	WxDxH	inch	52-5/8 x 34-1/2 x 12		
		mm	1338 x 877 x 305		
Net Weight/Gross Weight		lb	104/119		
		kg	47/54		

\* The noise level is measured 1/16 inch from the bottom center of the unit, in the semi-anechoic room. It will be slightly higher due to change of the environment during actual operation. The noise level is measured under the standard test condition. The noise level is measured under the condition of rear air return.

# High Static Pressure Ducted Type Indoor Units

## 18K to 96K BTU - 60 Hz (continued)

Model			BDDH-14.0(48)SAK	BDDH-22.0(72)-AK (1)	BDDH-28.0(96)-AK (1)
Capacity	Cooling	MBtu/h	48.0	69.0	92.0
		kW	14.0	20.0	27.0
	Heating	MBtu/h	54.0	77.0	103.0
		kW	15.8	22.6	30.2
Power Supply		Ph-V-Hz	1-208~230-60		
Power Consumption		W	220	800	900
Airflow Volume (H/M/L)		M <sup>3</sup> /Hr	2000/1700/1400	4000	4400
		CFM	1175/1000/824	2355/2100/1990	2590/2405/2300
Rated Current <sup>2</sup>	Cooling	A	1.0	4.1	4.6
	Heating	A	1.0	4.1	4.6
ESP		Pa (in. wc)	70/0~100 (0.28/0.40)	150/50~200 (0.60/0.20~0.80)	
Sound Level* (H/M/L)		dB(A)	48/46/44	54/51/49	55/52/50
Connecting Pipe Diameter	Liquid Line	in. (mm)	3/8 (9.52)		
	Suction Line	in. (mm)	5/8 (15.9)	7/8 (22.2)	
Drain Pipe	External Diameter	in. (mm)	1 (25.4)	1-3/16 (30)	
	Thickness	inch	3/32	1/16	
Outline Dimension	WxDxH	inch	48-3/8 x 30-1/2 x 11-1/2	58-3/8 x 31-1/8 x 15-1/8	66-3/8 x 34-1/4 x 17-3/4
		mm	1271 x 558 x 268	1483 x 791 x 385	1686 x 870 x 450
Package Dimension	WxDxH	inch	52-1/2 x 34-1/2 x 11-1/2	69-1/4 x 34-3/4 x 18-1/2	70-3/8 x 38-7/8 x 22-7/8
		mm	1348 x 597 x 283	1758x883x470	1788 x 988 x 580
Net Weight/Gross Weight		lb	104/119	181/229	231/309
		kg	47/54	82/104	105/140

\* The noise level is measured 1/16 inch from the bottom center of the unit, in the semi-anechoic room. It will be slightly higher due to change of the environment during actual operation.  
The noise level is measured under the standard test condition. The noise level is measured under the condition of rear air return.

(1) No condensate pump

# Low Static Pressure Ducted Type Indoor Units



## Low Static Pressure Ducted Type Indoor Unit

### Quiet

Provides a comfortable and quiet environment. It's especially suitable for smaller rooms or where installation space is limited.

### Intelligent Condensate Drain

Intelligent condensate drain pump can effectively drain up to 39 inches in height, saving space. WRC1 controller included. Basic washable filters included.

### Easy Installation and Maintenance

Several features have been included in this model for easy installation and maintenance including

- Tabbed plastic filter
- Detachable fan motor
- Independent water pump assembly
- Electrical box assembly

### Protection Function

The system monitors itself for:

- Freeze protection
- Fan motor overload
- Temperature sensor malfunction

# Low Static Pressure Ducted Type Indoor Units

7K to 22K BTU - 60 Hz

Model			BDDL-2.2(07)SAK	BDDL-2.8(09)SAK	BDDL-3.6(12)SAK
Capacity	Cooling	MBtu/h	7.5	9.5	12.0
		kW	2.2	2.8	3.6
	Heating	MBtu/h	8.5	10.5	13.5
		kW	2.5	3.1	4.0
Power Supply		Ph-V-Hz	1-208~230-60		
Power Consumption		W	35		43
Airflow Volume (H/M/L)		M <sup>3</sup> /Hr	450/350/250		550/450/350
		CFM	265/206/147		325/265/206
Rated Current <sup>2</sup>	Cooling	A	0.2		
	Heating	A	0.2		
ESP		Pa (in. wc)	15/0~30 (0.06/0~0.12)		
Sound Level* (H/M/L)		dB(A)	31/28/25		32/30/27
Connecting Pipe Diameter	Liquid Line	in. (mm)	1/4 (6.35)		
	Suction Line	in. (mm)	1/2 (9.52)		1/2 (12.7)
Drain Pipe	External Diameter	in. (mm)	1 (25)		
	Thickness	inch	3/32		
Outline Dimension	WxDxH	inch	27-1/2 x 24-1/4 x 7-7/8		
		mm	700 x 615 x 200		
Package Dimension	WxDxH	inch	35-1/8 x 29-1/4 x 11.5		
		mm	893 x 743 x 305		
Net Weight/Gross Weight		lb	51/64		
		kg	22/27		22/28

Model			BDDL-4.1(14)SAK	BDDL-5.6(18)SAK	BDDL-6.3(22)SAK
Capacity	Cooling	MBtu/h	14.0	18.0	22.0
		kW	4.0	5.6	6.3
	Heating	MBtu/h	15.0	20.0	24.0
		kW	4.5	5.9	7.1
Power Supply		Ph-V-Hz	1-208~230-60		1-208~230-60
Power Consumption		W	52	99	99
Airflow Volume (H/M/L)		M <sup>3</sup> /Hr	700/600/450	1000/800/600	1000/800/600
		CFM	410/355/265	590/471/355	590/471/355
Rated Current <sup>2</sup>	Cooling	A	0.3	0.5	0.5
	Heating	A	0.3	0.5	0.5
ESP		Pa (in. wc)	15/0~30 (0.06/0~0.12)		15/0~30 (0.06/0~0.12)
Sound Level* (H/M/L)		dB(A)	33/31/28	35/33/30	35/33/30
Connecting Pipe Diameter	Liquid Line	in. (mm)	1/4 (6.35)	3/8 (9.52)	3/8 (9.52)
	Suction Line	in. (mm)	1/2 (12.7)	5/8 (15.9)	5/8 (15.9)
Drain Pipe	External Diameter	in. (mm)	1 (25)		1 (25)
	Thickness	inch	3/32		3/32
Outline Dimension	WxDxH	inch	35-3/8 x 24-1/4 x 7-7/8	43-1/4 x 24-1/4 x 7-7/8	43-1/4 x 24-1/4 x 7-7/8
		mm	900 x 615 x 200	1100 x 615 x 200	1100 x 615 x 200
Package Dimension	WxDxH	inch	44-1/4 x 29-1/4 x 12	52-1/8 x 29-1/4 x 12	52-1/8 x 29-1/4 x 12
		mm	1123 x 743 x 305	1323 x 743 x 305	1323 x 743 x 305
Net Weight/Gross Weight		lb	60/73	68/84	68/84
		kg	27/33	31/38	31/38

\* The noise level is measured 1/16 inch from the bottom center of the unit, in the semi-anechoic room. It will be slightly higher due to change of the environment during actual operation. The noise level is measured under the standard test condition. The noise level is measured under the condition of rear air return.

## 4-Way Cassette Indoor Units

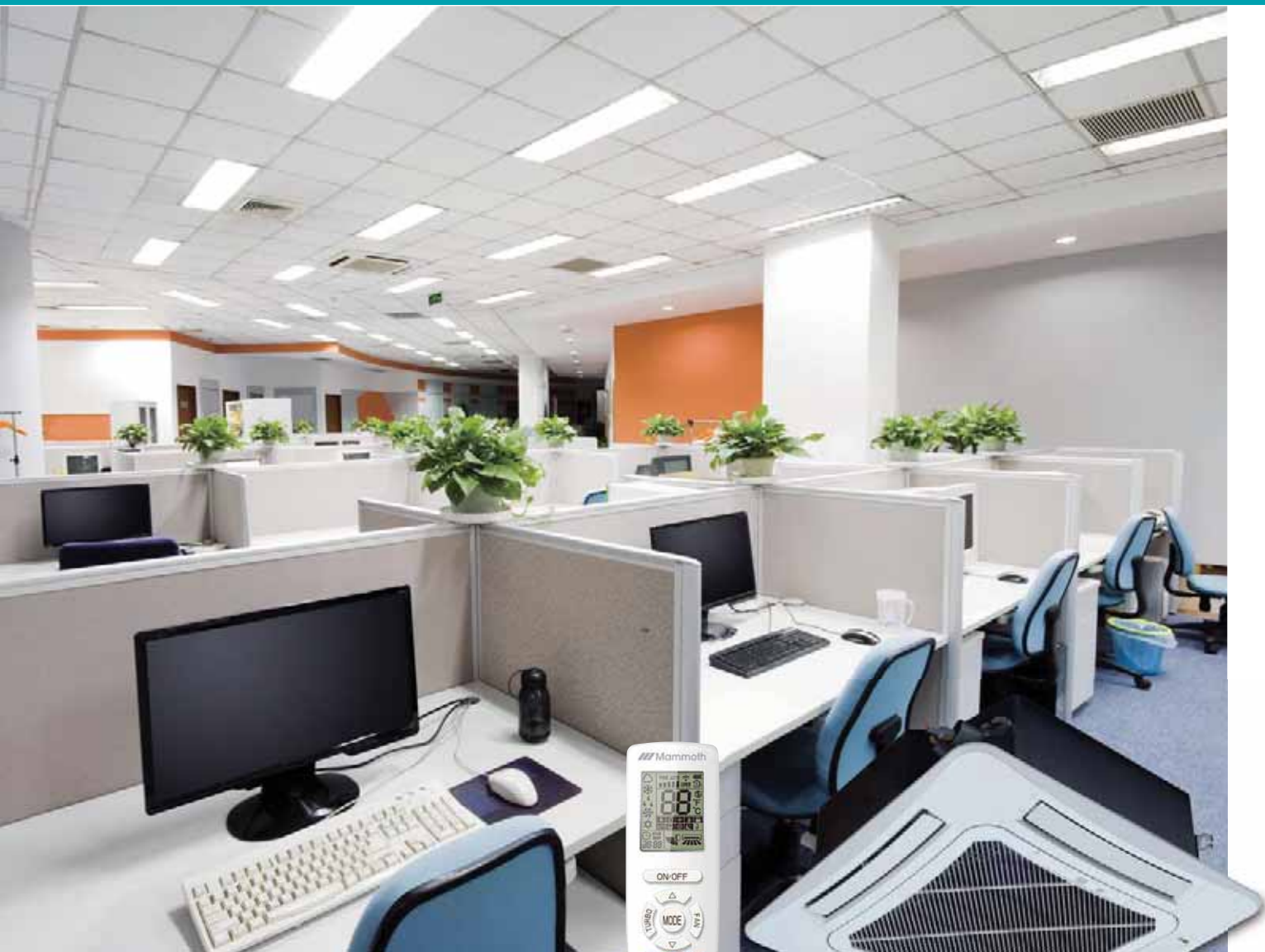

### 4-Way Cassette Indoor Unit

#### **Strong and Balanced Airflow**

The 4-way airflow unit features auto operation, seven fan speeds and strong airflow.

#### **Ultra Quiet Operation**

DC inverter motor offers stepless speed regulation for quieter operation. The wired controller can be set to normal operation or auto quiet mode.

#### **Intelligent Condensate Pump**

Condensate water can be pumped up to 39 inches vertically from indoor unit.

#### **DC Inverter Motor**

The DC inverter motor improves efficiency 30% vs conventional motor. Increased efficiency reduces operating costs.

#### **Protection Functions**

The system monitors itself for:

- Freeze protection
- Fan motor overload
- Temperature sensor malfunction

# 4-Way Cassette Indoor Units

7K to 48K BTU - 60 Hz

Model		BD4W-2.2(07)SAK		BD4W-2.8(09)SAK		BD4W-3.6(12)SAK	
Capacity	Cooling	MBtu/h	7.5	9.5	12.0		
		kW	2.2	2.8	3.5		
	Heating	MBtu/h	8.5	10.5	13.5		
		kW	2.5	3.1	4.0		
Power Supply		Ph-V-Hz	1-208~230-60				
Power Consumption		W	48	59			
Airflow Volume (H/M/L)		M <sup>3</sup> /Hr	750/650/550		1000/900/750		
		CFM	440/385/325		590/530/440		
Rated Current <sup>2</sup>	Cooling	A	0.3		0.5		
	Heating	A	0.3		0.5		
Sound Level* (H/M/L)		dB(A)	36/34/31		37/35/32		
Connecting Pipe Diameter	Liquid Line	in. (mm)	1/4 (6.35)				
	Suction Line	in. (mm)	3/8 (9.52)		1/2 (12.7)		
Drain Pipe	External Diameter	in. (mm)	1 (25)				
	Thickness	inch	3/32				
<b>Main Body</b>							
Outline Dimension	WxDxH	inch	33 x 33 x 7-1/2		33 x 33 x 9-1/2		
		mm	838 x 838 x 191		838 x 838 x 241		
Package Dimension	WxDxH	inch	37-15/16 x 37-15/16 x 10-11/16		37-15/16 x 37-15/16 x 12-13/16		
		mm	964 x 964 x 271		964 x 964 x 325		
Net Weight/Gross Weight		lb	50/64		58/75		
		kg	23/29		26/34		
<b>Panel</b>							
Outline Dimension	WxDxH	inch	37-3/8 x 37-3/8 x 2-1/2				
		mm	949 x 949 x 64				
Package Dimension	WxDxH	inch	40-11/16 x 40-7/8 x 5-1/4		40-5/8 x 40-7/8 x 5-1/4		
		mm	1033 x 1038 x 133		1032 x 1038 x 133		
Net Weight/Gross Weight		lb	15/24				
		kg	7/11				

Model		BD4W-5.0(18)SAK		BD4W-7.1(24)SAK		BD4W-9.0(30)SAK	
Capacity	Cooling	MBtu/h	18.0	24.0	30.0		
		kW	5.0	7.1	9.0		
	Heating	MBtu/h	20.0	27.0	34.0		
		kW	5.9	8.0	10.0		
Power Supply		Ph-V-Hz	1-208~230-60				
Power Consumption		W	59		98		
Airflow Volume (H/M/L)		M <sup>3</sup> /Hr	1000/900/750		1180/950/850		1500/1350/1100
		CFM	590/530/440		695/560/550		885/795/650
Rated Current <sup>2</sup>	Cooling	A	0.5		0.8		
	Heating	A	0.5		0.8		
Sound Level* (H/M/L)		dB(A)	37/35/32		38/36/33		40/38/35
Connecting Pipe Diameter	Liquid Line	in. (mm)	3/8 (9.52)				
	Suction Line	in. (mm)	5/8 (15.9)				
Drain Pipe	External Diameter	in. (mm)	1 (25)				
	Thickness	mm	3/32				
<b>Main Body</b>							
Outline Dimension	WxDxH	inch	33 x 33 x 9-1/2				
		mm	838 x 838 x 241				
Package Dimension	WxDxH	inch	37-15/16 x 37-15/16 x 12-13/16		37-15/16 x 37-15/16 x 16-1/8		
		mm	964 x 964 x 325		964 x 964 x 410		
Net Weight/Gross Weight		lb	58/75		72/88		
		kg	26/34		32.5/40.0		
<b>Panel</b>							
Outline Dimension	WxDxH	inch	37-3/8 x 37-3/8 x 2-1/2				
		mm	949 x 949 x 64				
Package Dimension	WxDxH	inch	40-11/16 x 40-7/8 x 5-1/4				
		mm	1033 x 1038 x 133				
Net Weight/Gross Weight		lb	15/24				
		kg	7/11				

\* The noise level is measured 1/16 inch from the bottom center of the unit, in the semi-anechoic room. It will be slightly higher due to change of the environment during actual operation. The noise level is measured under the standard test condition. The noise level is measured under the condition of rear air return.

# 4-Way Cassette Indoor Units

7K to 48K BTU - 60 Hz (continued)

Model			BD4W-11.2(36)SAK	BD4W-12.5(42)SAK	BD4W-14.0(48)SAK
Capacity	Cooling	MBtu/h	36.0	42.0	48.0
		kW	10.6	12.5	14.0
	Heating	MBtu/h	40.0	47.0	54.0
		kW	11.7	13.8	15.8
Power Supply		Ph-V-Hz	1-208~230-60		
Power Consumption		W	110		
Airflow Volume (H/M/L)		M <sup>3</sup> /Hr	1700/1400/1100	1860/1500/1150	
		CFM	1000/825/650	1095/880/675	
Rated Current <sup>2</sup>	Cooling	A	0.9		
	Heating	A	0.9		
Sound Level* (H/M/L)		dB(A)	41/38/36	43/41/38	
Connecting Pipe Diameter	Liquid Line	in. (mm)	3/8 (9.52)		
	Suction Line	in. (mm)	5/8 (15.9)		
Drain Pipe	External Diameter	in. (mm)	1 (25)		
	Thickness	inch	3/32		
<b>Main Body</b>					
Outline Dimension	WxDxH	inch	33 x 33 x 12-5/8		
		mm	838 x 838 x 321		
Package Dimension	WxDxH	inch	37-15/16 x 37-15/16 x 16-1/8		
		mm	964 x 964 x 410		
Net Weight/Gross Weight		lb	72/88		
		kg	32.5/40.0		
<b>Panel</b>					
Outline Dimension	WxDxH	inch	37-3/8 x 37-3/8 x 2-1/2		
		mm	950 x 950 x 65		
Package Dimension	WxDxH	inch	40-11/16 x 40-7/8 x 5-1/4		
		mm	1033 x 1038 x 133		
Net Weight/Gross Weight		lb	15/24		
		kg	7/11		

\* The noise level is measured 1/16 inch from the bottom center of the unit, in the semi-anechoic room. It will be slightly higher due to change of the environment during actual operation. The noise level is measured under the standard test condition. The noise level is measured under the condition of rear air return.



## 4-Way Compact Cassette Indoor Units



### 4-Way Compact Cassette Indoor Unit

Fits in a standard 2-by-2 ceiling grid.

#### **Strong and Balanced Airflow**

The 4-way airflow unit features auto operation, seven fan speeds and strong airflow.

#### **Ultra Quiet Operation**

DC inverter motor offers stepless speed regulation for quieter operation. The wired controller can be set to normal operation or auto quite mode.

#### **Intelligent Condensate Pump**

Condensate water can be pumped up to 39 inches vertically from indoor unit.

#### **DC Inverter Motor**

The DC inverter motor improves efficiency 30% vs conventional motor. Increased efficiency reduces operating costs.

#### **Protection Functions**

The system monitors itself for:

- Freeze protection
- Fan motor overload
- Temperature sensor malfunction

# 4-Way Compact Cassette Indoor Units

9K to 18K BTU - 60 Hz

Model			BD4WC-(2.8)09SAK	BD4WC-(3.6)12SAK	BD4WC-(4.4)15SAK	BD4WC-(5.6)18SAK
Capacity	Cooling	MBtu/h	9.5	12.0	15.0	18.0
		kW	2.8	3.5	4.4	5.3
	Heating	MBtu/h	10.5	13.5	17.0	20.0
		kW	3.1	4.0	5.0	5.9
Power Supply		Ph-V-Hz	1-208~230-60			
Power Consumption		W	0.035		0.045	
Airflow Volume (H/M/L)		M <sup>3</sup> /Hr	600/500/400		700/600/480	
		CFM	355/295/235		410/355/283	
Rated Current	MCA	A	1			
	MOCP	A	15			
Sound Level* (H/M/L)		dB(A)	41/39/35		45/43/38	
Refrigerant Piping Connection	Liquid Line	in. (mm)	1/4 (6.35)			3/8 (9.52)
	Suction Line	in. (mm)	3/8 (9.52)	1/2 (12.7)		5/8 (15.9)
Drain Pipe		in. (mm)	3/4 (19)			
<b>Main Body</b>						
Outline Dimension	WxDxH	inch	23-1/2 x 23-1/2 x 9-7/16			
		mm	596 x 596 x 240			
Package Dimension	WxDxH	inch	30-1/2 x 28-15/16 x 11-1/4			
		mm	775 x 735 x 285			
Net Weight/Gross Weight		lb	48.5/59.5			
		kg	22/27			
<b>Panel</b>						
Outline Dimension	WxDxH	inch	26-3/8 x 26-3/8 x 1			
		mm	970 x 670 x 50			
Package Dimension	WxDxH	inch	29-15/16 x 29-15/16 x 3-1/2			
		mm	760 x 760 x 90			
Net Weight/Gross Weight		lb	8.8/11			
		kg	4/5			

\* The noise level is measured 1/16 inch from the bottom center of the unit, in the semi-anechoic room. It will be slightly higher due to change of the environment during actual operation. The noise level is measured under the standard test condition. The noise level is measured under the condition of rear air return.

## 2-Way Cassette Indoor Units

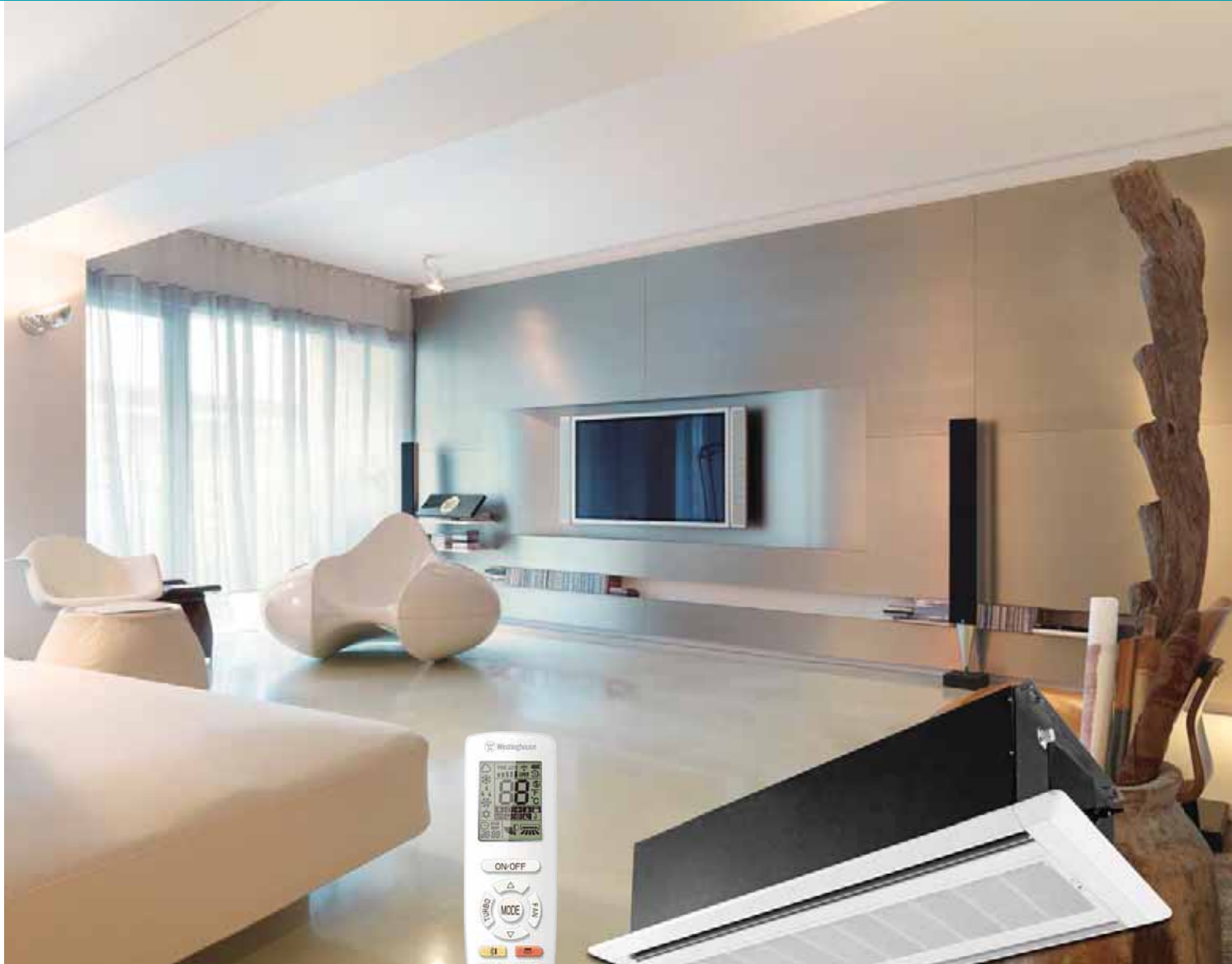

### 2-Way Cassette Indoor Unit

These units are used in larger rectangular spaces, such as hallways and offices. Units have adjustable louvers to ensure customizable air distribution. This can help prevent cold drafts for office occupants.

#### **Attractive Appearance**

The elegant, attractive front panel coordinates nicely with the indoor decor.

#### **Intelligent Condensate Pump**

Condensate water can be pumped up to 39 inches vertically from indoor unit.

#### **2-Way Airflow Design**

The 2-way air outlet improves airflow providing comfort and even air distribution in more elongated rooms.

#### **Protection Functions**

The system monitors itself for:

- Freeze protection
- Fan motor overload
- Temperature sensor malfunction
- Humidity
- Free panel included

# 2-Way Cassette Indoor Units

## 9K to 24K BTU - 60 Hz (continued)

Model			BD2W-2.8(09)SAK	BD2W-3.6(12)SAK	BD2W-4.5(15)SAK
Capacity	Cooling	MBtu/h	9.5	12.0	15.0
		kW	2.8	3.6	4.5
	Heating	MBtu/h	11.0	13.5	18.0
		kW	3.2	4.0	5.0
Power Supply		Ph-V-Hz	1-220-240-50 & 1-208-230-60		
Power Consumption		W	55		
Airflow Volume (H/M/L)		M <sup>3</sup> /Hr	830/600/530		
		CFM	490/355/312		
Rated Current <sup>2</sup>	Cooling	A	0.3		
	Heating	A	0.3		
Sound Pressure* (H/M/L)		dB(A)	35/33/31		
Connecting Pipe Diameter	Liquid Line	in. (mm)	1/4 (6.35)		
	Suction Line	in. (mm)	3/8 (9.52)	1/2 (12.7)	
Drain Pipe	External Diameter	in. (mm)	1 (25)		
	Thickness	in. (mm)	3/32 (2.5)		
<b>Main Body</b>					
Outline Dimension		WxDxH	inch 47 x 20 x 13		
Package Dimension		WxDxH	inch 60 x 26 x 17		
Net Weight/Gross Weight		lb	89/116		
<b>Panel</b>					
Outline Dimension		WxDxH	inch 56 x 25 x 1		
Package Dimension		WxDxH	inch 62 x 30 x 5		
Net Weight/Gross Weight		lb	95/119		

Model			BD2W-5.0(18)SAK	BD2W-7.1(24)SAK
Capacity	Cooling	MBtu/h	18.0	24.0
		kW	5.3	7.0
	Heating	MBtu/h	20.0	27.0
		kW	5.6	7.9
Power Supply		Ph-V-Hz	1-220-240-50 & 1-208-230-60	
Power Consumption		W	55	103.0
Airflow Volume (H/M/L)		M <sup>3</sup> /Hr	830/600/530	1100/820/760
		CFM	490/355/312	445/485/650
Rated Current <sup>2</sup>	Cooling	A	0.3	0.7
	Heating	A	0.3	0.7
Sound Pressure* (H/M/L)		dB(A)	35/33/31	39/37/35
Connecting Pipe Diameter	Liquid Line	in. (mm)	3/8 (9.52)	
	Suction Line	in. (mm)	5/8 (15.9)	
Drain Pipe	External Diameter	in. (mm)	1 (25)	
	Thickness	in. (mm)	3/32 (2.5)	
<b>Main Body</b>				
Outline Dimension		WxDxH	47-1/4 x 20-1/2 x 13-3/8	47-1/4 x 20-1/2 x 13-3/8
Package Dimension		WxDxH	59-7/8 x 25-3/4 x 16-3/8	59-7/8 x 25-3/4 x 16-3/8
Net Weight/Gross Weight		lb	95/121	95/121
<b>Panel</b>				
Outline Dimension		WxDxH	56-3/4 x 24-3/4 x 1-1/4	56-3/4 x 24-3/4 x 1-1/4
Package Dimension		WxDxH	62 x 30-1/8 x 4-1/8	62 x 30-1/8 x 4-1/8
Net Weight/Gross Weight		lb	15/24	15/24

\* The noise level is measured 1.4 meters from the bottom center of the unit, in the semi-anechoic room. It will be slightly higher due to change of the environment during actual operation. The noise level is measured under the standard test condition. The noise level is measured under the condition of rear air return.

## Wall-Mounted Indoor Units



### Wall-Mounted Indoor Unit

#### Up & Down Air Outlet

During summer, cool air is supplied horizontally through the upper air outlet. Cool air entering the room will drop to the floor.

During winter, warm air is supplied downward through the lower air outlet. Warm air is directed toward the floor where it is needed. Warm air will then rise for even heating.

#### Triple Defender Filter

The electrostatic, anti-biotic fibre filter removes dust, odors, bacteria and mildew. Free controllers and filters.

#### Warm Air Design

During winter, the cold air prevention function is enabled so that the heater will warm before the fan is engaged providing warm air from the start.

#### Protection Functions

The system monitors itself for:

- Freeze protection
- Fan motor overload
- Temperature sensor malfunction
- Error code indicator

# Wall-Mounted Indoor Units - 60Hz

## 7K to 24K BTU - 60 Hz

Model			B-HW-2.2(07)A3AK	B-HW-2.8(09)A3AK	B-HW-3.6(12)A3AK
Capacity	Cooling	MBtu/h	7.5	9.5	12.0
		kW	2.2	2.8	3.6
	Heating	MBtu/h	8.5	11.0	13.5
		kW	2.5	3.2	4.0
Power Supply		Ph-V-Hz	1-208/230-60		
Power Consumption		W	50		60
Airflow Volume (H/M/L)		M <sup>3</sup> /Hr	500/420/350		630/550/480
		CFM	294/247/206		371/324/282
Rated Current <sup>2</sup>	Cooling	A	0.2		0.31
	Heating	A	0.2		0.31
Sound Level* (H/M/L)		dB(A)	38/34/30		44/41/38
Connecting Pipe Diameter	Liquid Line	in. (mm)	1/4 (6.35)		
	Suction Line	in. (mm)	3/8 (9.52)		1/2 (12.7)
Drain Pipe	External Diameter	in. (mm)	25/32 (20)		
	Thickness	inch	1-1/2	1/16	
Outline Dimension	WxDxH	inch	33-1/4 x 7-1/8 x 10-7/8		37 x 7-7/8 x 11
		mm	843 x 180 x 275		940 x 200 x 298
Package Dimension	WxDxH	inch	38-1/4 x 10-1/8 x 14-5/8		42 x 11-3/8 x 15-1/2
		mm	973 x 258 x 370		1068 x 288 x 395
Net Weight/Gross Weight		lb	22/28		28/34
		kg	10/12.5		12.5/15.5

Model			B-HW-5.0(18)A3AK	B-HW-7.1(24)A3AK
Capacity	Cooling	MBtu/h	18.0	24.0
		kW	5.0	7.1
	Heating	MBtu/h	20.0	26.0
		kW	5.8	7.5
Power Supply		Ph-V-Hz	1-208/230-60	
Power Consumption		W	60	70
Airflow Volume (H/M/L)		M <sup>3</sup> /Hr	630/550/480	750/600/500
		CFM	371/324/282	441/353/294
Rated Current <sup>2</sup>	Cooling	A	0.31	
	Heating	A	0.31	
Sound Level* (H/M/L)		dB(A)	44/41/38	
Connecting Pipe Diameter	Liquid Line	in. (mm)	1/4 (6.35)	3/8 (9.52)
	Suction Line	in. (mm)	1/2 (12.7)	5/8 (15.9)
Drain Pipe	External Diameter	in. (mm)	1-1/8 (25)	1-3/16 (30)
	Thickness	inch	1/16	
Outline Dimension	WxDxH	inch	37 x 7-7/8 x 12	39-5/8 x 8-3/4 x 12-1/2
		mm	940 x 200 x 298	1008 x 221 x 319
Package Dimension	WxDxH	inch	42 x 11-3/8 x 15-1/2	44-1/2 x 15-5/8 x 12-7/8
		mm	1068 x 288 x 395	1131 x 398 x 328
Net Weight/Gross Weight		lb	28/34	33/41
		kg	12.5/15.5	15/18.5

\* The noise level is measured 1/16 inch from the bottom center of the unit, in the semi-anechoic room. It will be slightly higher due to change of the environment during actual operation. The noise level is measured under the standard test condition. The noise level is measured under the condition of rear air return.

# Floor/Ceiling Type Indoor Units



## Floor/Ceiling Type Indoor Unit

Great for spaces requiring great air-throw with limited installation locations.

### Flexible Installation

Floor ceiling unit can be mounted overhead in a hoisted position or may be mounted in seated position on the wall, close to the floor.

### Attractive Appearance

The elegant, attractive front panel coordinates nicely with any décor.

### Condensate Pump

Convenient space provided for condensate pump installation.

### Protection Functions

The system monitors itself for:

- Freeze protection
- Fan motor overload
- Temperature sensor malfunction
- Horizontal and Vertical Air Swing
- Provides a wider air swing range for a comfortable working and living environment.

# Floor/Ceiling Type Indoor Units

## 9K to 48K BTU - 60 Hz

Model			BDFC-2.8(09)-AK	BDFC-3.6(12)-AK	BDFC-5.0(18)-AK	BDFC-7.1(24)-AK
Capacity	Cooling	MBtu/h	9.5	12.0	18.0	24.0
		kW	2.8	3.6	5.3	7.0
	Heating	MBtu/h	10.5	13.5	20.0	27.0
		kW	3.1	4.0	5.9	7.9
Power Supply		Ph-V-Hz	1-208~230-60			
Power Consumption		W	40		50	75
Airflow Volume (H/M/L)		M <sup>3</sup> /Hr	650/580/500		950/850/700	1400/1150/1000
		CFM	380/341/294		560/500/410	825/677/590
Rated Current <sup>2</sup>	Cooling	A	0.2		0.25	0.38
	Heating	A	0.2		0.25	0.38
Sound Level* (H/M/L)		dB(A)	36/34/32		42/38/33	44/42/39
Connecting Pipe Diameter	Liquid Line	in. (mm)	1/4 (6.35)			3/8 (9.52)
	Suction Line	in. (mm)	3/8 (9.52)	1/2 (12.7)	5/8 (15.9)	
Drain Pipe	External Diameter	in. (mm)	21/32 (17)			
	Thickness	inch	1/16			
Outline Dimension	WxDxH	inch	48 x 27-1/2 x 8-7/8			55-7/8 x 27-1/2 x 9-5/8
		mm	1220 x 700 x 225			1420 x 700 x 245
Package Dimension	WxDxH	inch	52-7/8 x 32-3/8 x 12-3/8			61 x 32-5/8 x 13-5/8
		mm	1343 x 823 x 315			1548 x 828 x 345
Net Weight/Gross Weight		lb	88/108		110/128	
		kg	40/49		50/58	

Model			BDFC-9.0(30)-AK	BDFC-11.2(36)-AK	BDFC-12.5(42)-AK	BDFC-14.0(48)-AK
Capacity	Cooling	MBtu/h	30.0	36.0	42.0	48.0
		kW	8.8	10.6	12.3	14.1
	Heating	MBtu/h	33.0	40.0	47.0	54.0
		kW	10.0	11.7	13.8	15.8
Power Supply		Ph-V-Hz	1-208~230-60			
Power Consumption		W	140	160		
Airflow Volume (H/M/L)		M <sup>3</sup> /Hr	1600/1400/1200	2000/1800/1450		
		CFM	940/824/706	1175/1059/853		
Rated Current <sup>2</sup>	Cooling	A	0.7	0.95		
	Heating	A	0.7	0.95		
Sound Level* (H/M/L)		dB(A)	50/47/43	51/47/42	52/49/45	
Connecting Pipe Diameter	Liquid Line	in. (mm)	3/8 (9.52)			
	Suction Line	in. (mm)	5/8 (15.9)			
Drain Pipe	External Diameter	in. (mm)	21/32 (17)			
	Thickness	inch	1/16			
Outline Dimension	WxDxH	inch	55-7/8 x 27-1/2 x 9-5/8	66-7/8 x 27-1/2 x 9-5/8		
		mm	1420 x 700 x 245	1700 x 700 x 245		
Package Dimension	WxDxH	inch	61 x 32-5/8 x 13-5/8	72 x 32-5/8 x 14		
		mm	1548 x 828 x 345	1828 x 828 x 345		
Net Weight/Gross Weight		lb	110/128	132/150		
		kg	50/58	60/68		

\* The noise level is measured 1/16 inch from the bottom center of the unit, in the semi-anechoic room. It will be slightly higher due to change of the environment during actual operation. The noise level is measured under the standard test condition. The noise level is measured under the condition of rear air return.



## Console Type Indoor Units



### Console Type Indoor Unit

Great for radiator-type and knee-wall installations, like finished attic spaces with low walls.

#### Multiple Fan Speed

Adjustable fan operates in multiple speeds and satisfy different airflow volume requirements.

#### Detachable Grille and Long Life Filter

The front grille is easily detachable for easy filter cleaning. A durable, long-life, washable filter is included.

#### Protection Functions

The system monitors itself for:

- Freeze protection
- Fan motor overload
- Temperature sensor malfunction

# Console Type Indoor Units

7K to 18K BTU - 60 Hz

Model			BDC0-2.2(07)-AK	BDC0-2.8(09)-AK	BDC0-3.6(12)-AK	BDC0-5.0(18)-AK
Capacity	Cooling	MBtu/h	2.2	9.5	12.0	18.0
		kW	7.5	2.8	3.5	5.3
	Heating	MBtu/h	2.5	11.0	13.5	20.0
		kW	8.5	3.2	4.0	5.8
Power Supply		Ph-V-Hz	1-208-230-60			
Power Consumption		W	15		20	40
Airflow Volume (H/M/L)		M <sup>3</sup> /Hr	400/320/270		480/400/310	680/600/500
		CFM	235/188/159		282/235/182	400/353/294
Rated Current <sup>2</sup>	Cooling	A	0.15			
	Heating	A	0.15			
ESP		Pa (in. wc)	0			
Sound Level* (H/M/L)		dB(A)	38/33/27		40/37/32	46/43/39
Connecting Pipe Diameter	Liquid Line	in. (mm)	1/4 (6.35)			
	Suction Line	in. (mm)	3/8 (9.52)			1/2 (12.7)
Drain Pipe	External Diameter	in. (mm)	11/16 (17.2)			
	Thickness	inch	3/64			
Outline Dimension	WxDxH	inch	27-1/2 x 8-1/2 x 23-5/8			
		mm	700 x 215 x 600			
Package Dimension	WxDxH	inch	30-3/4 x 11-1/4 x 26-7/8			
		mm	780 x 285 x 682			
Net Weight/Gross Weight		lb	35/42			
		kg	16/19			

\* The noise level is measured 1/16 inch from the bottom center of the unit, in the semi-anechoic room. It will be slightly higher due to change of the environment during actual operation. The noise level is measured under the standard test condition. The noise level is measured under the condition of rear air return.

## VRF Accessories



### VRF Accessories Simplify Installation

Mammoth offers a complete line of accessories to meet the requirements of any job small to large.

- Selection Software
- Fresh Air Processing
- Commissioning Software

# VRF Accessories - Selection Software

## VRF Selection Software

The Mammoth VRF Selection Software is an advanced computer program that accurately selects models based on your customers' needs. It integrates VRF Selection Logic, Piping Rules, and unit limitations in an easy-to-use user-friendly interface, eliminating the headaches of manual equipment selection. The software produces an error-free and organized spreadsheet to pass along to your customer.



# VRF Accessories - Selection Software

## VRF Selection Software (continued)

### Flexible Setting of Project Design Conditions

When setting up a new project simply enter the customer, designer, and unit series information. This will be output by the selection software in an easy-to-read format when the equipment selection is complete. Entering your design conditions will help the software accurately determine the size of equipment that is needed.

**VRF Selector**

**Project information**

Project: Smith Apartments      Location: Anytown, USA  
 Design time: 2017-07-10      Contract No: 123456

**Customer information**

Name: John Smith      Job: Project Manager  
 Company: Smith Holdings      Address: 123 Any Street, Ar  
 Phone: 808-555-1234      Fax: 808-555-4321  
 Save customer

**Designer information**

Name: Jane Doe      Job: PE  
 Company: PE LLC      Address: 123 Avenue E, An  
 Phone: 404-555-1234      Fax: 404-555-4321  
 Save designer

Project Setting

**VRF Selector**

**Confirm information**

**Designer Information**  
 Name: Jane Doe  
 Job: PE  
 Company: PE LLC  
 Address: 123 Avenue E, Anyville, USA  
 Phone: 404-555-1234  
 Fax: 404-555-4321

**Project**  
 Name: Smith Apartments  
 Frequency: 60Hz  
 Type: Office building  
 Allocation Rate: 1  
 Check Aotu  
 Room Num: 13

**Design Load Cool**  
 Indoor Cool  
 Dry bulb: 80.6°F  
 Wet bulb: 66.2°F  
 Relative humidity: 45.77%  
 Outdoor Cool  
 Dry bulb: 95°F

**Last step   Next   Complete**

Confirmation

**VRF Selector**

ODU Function: HeatRecovery  
 Power: 208-230V 3Ph 60Hz  
 Building type: Office building      IDU and ODU capacity rate: 100

**Design load**  
 Cooling load     Heating load     Both cool load and heat load

**Project design condition**

**Cooling**

Indoor  
 Dry bulb: 80.60 °F  
 Wet bulb: 66.20 °F  
 Humidity: 45.77 %

Outdoor  
 Dry bulb: 95.00 °F

**Heating**

Indoor  
 Dry bulb: 68.00 °F

Outdoor  
 Dry bulb: 44.60 °F  
 Wet bulb: 42.80 °F  
 Humidity: 85.36 %

Check method:  Auto     Manual

**Other information**  
 Room: 13

**Last step   Next**

Project Design Conditions

# VRF Accessories - Selection Software

## Indoor Unit Selection

Adding an indoor unit is simple: simply drag-and-drop the desired model from the left side onto the selection field. Then you double-click the unit to enter the required load and click "recommend" and the software will accurately select the size of the unit that is needed. Repeat these steps for all desired additional indoor units.

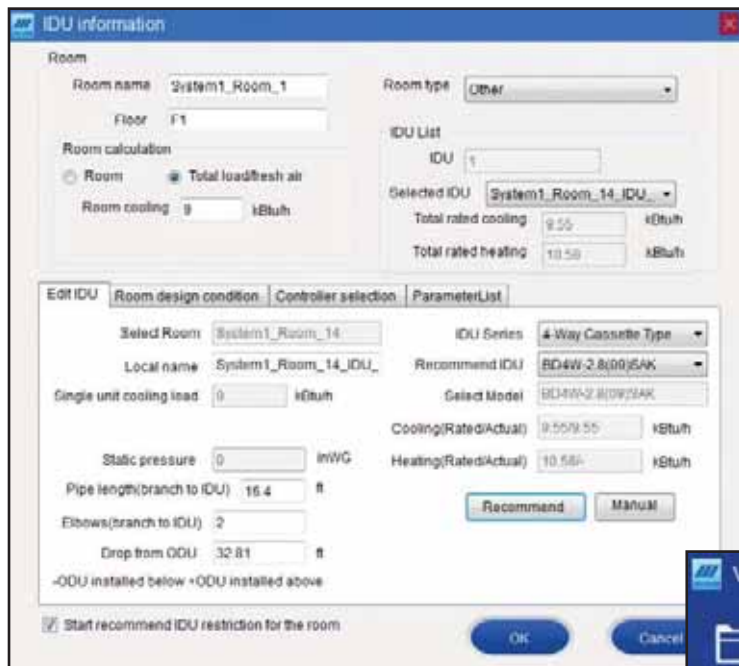

Add New Indoor Unit 2



Add New Indoor Unit 1

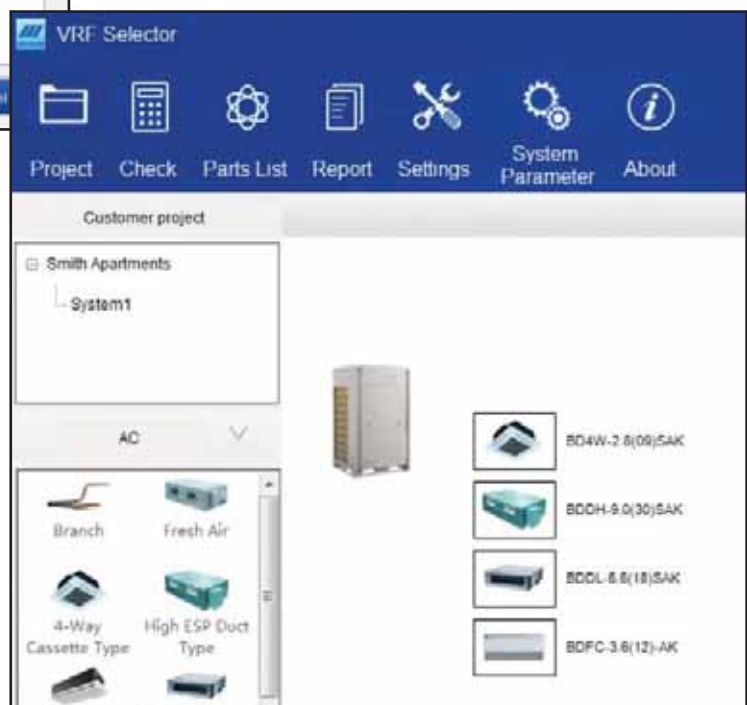

Add New Indoor Unit 3

# VRF Accessories - Selection Software

## Add Y-Branches or Mode Exchange Units

In a Heat Pump System, you'll add Y-branches to distribute refrigerant to the indoor units. To add, simply drag-and drop a Y-Branch from the left side onto the selection field. In a Heat Recovery System, you'll add Mode Exchange Units. These enable simultaneous heating and cooling operation. Simply drag-and-drop a Mode Exchange Unit from the left side onto the selection field.

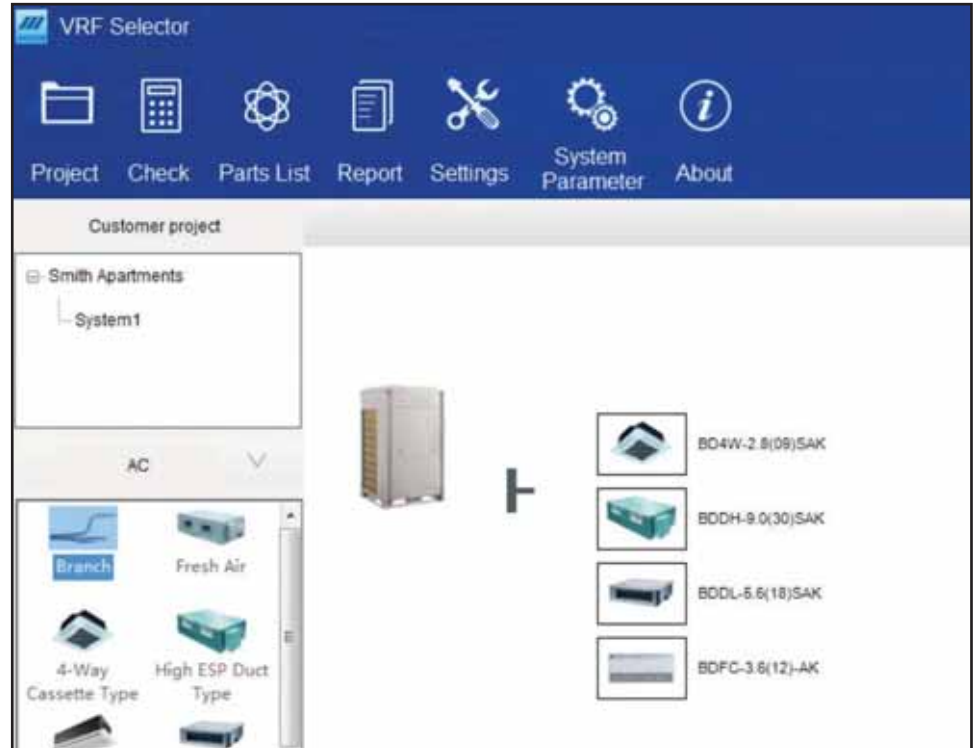

Add Y-Branches

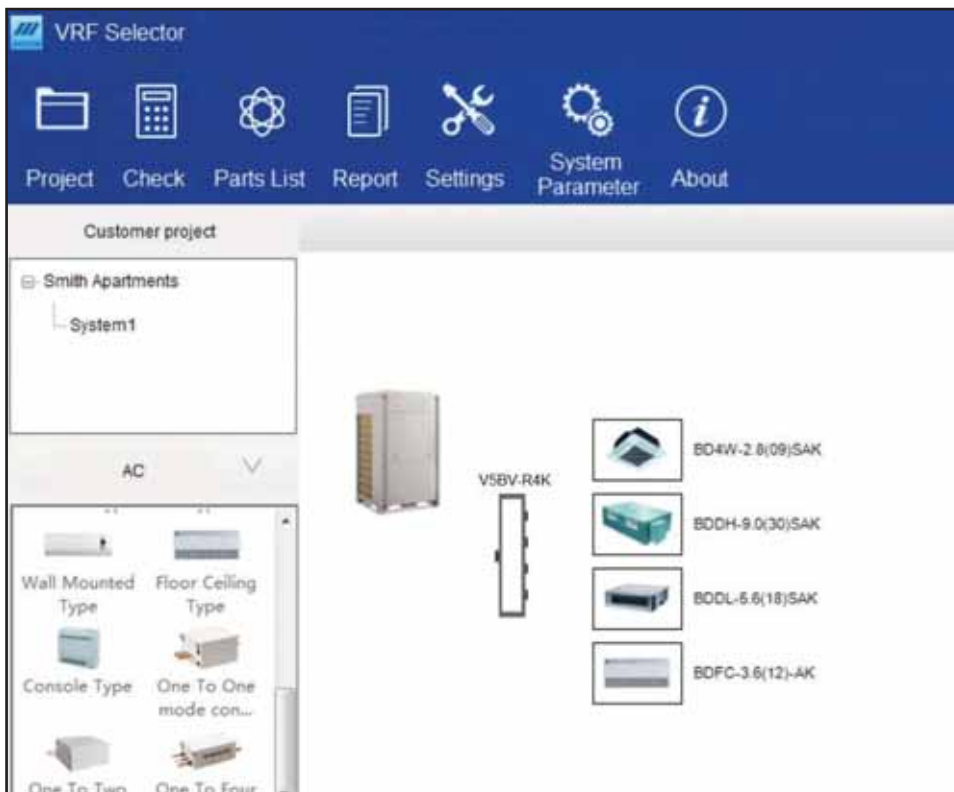

Add Mode Exchange Unit

# VRF Accessories - Selection Software

## Flexible Piping Connection

To connect your piping in the software, simply click on a unit and then click on a Y-Branch, Mode Exchange Unit, or Outdoor Unit. This simulates the piping connections in your systems. Accurate piping lengths are important in design, so you'll double click on a piping run and enter the length. This information will let you know how much additional refrigerant charge will be needed at commissioning and lets the software know if maximum piping lengths have been exceeded.

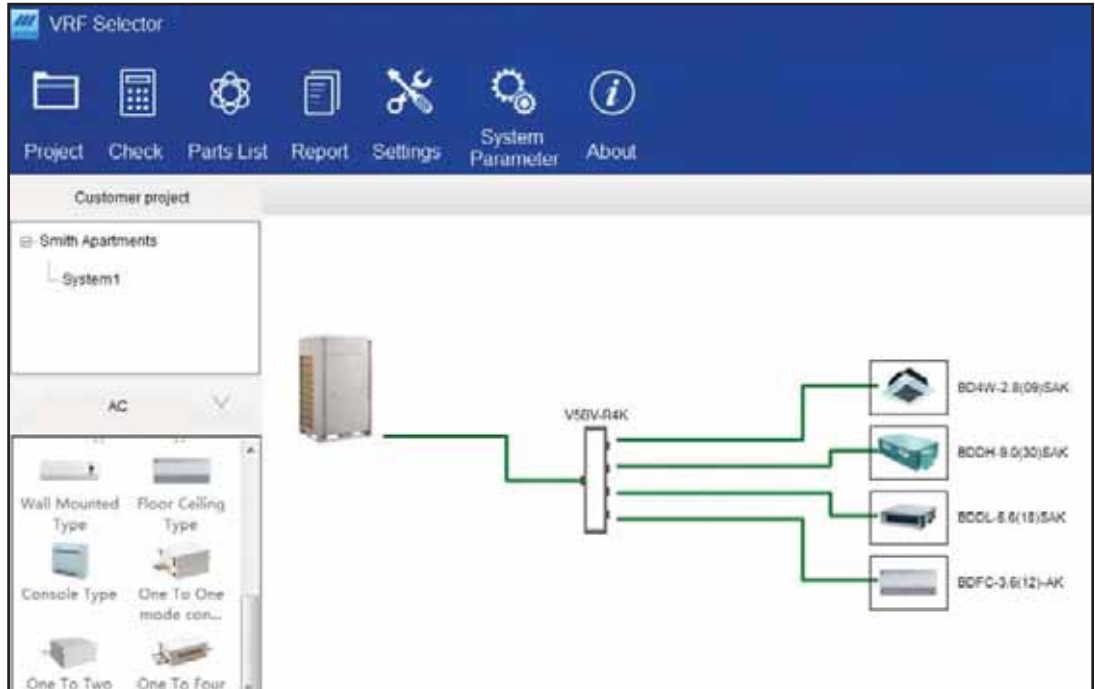

Add Piping

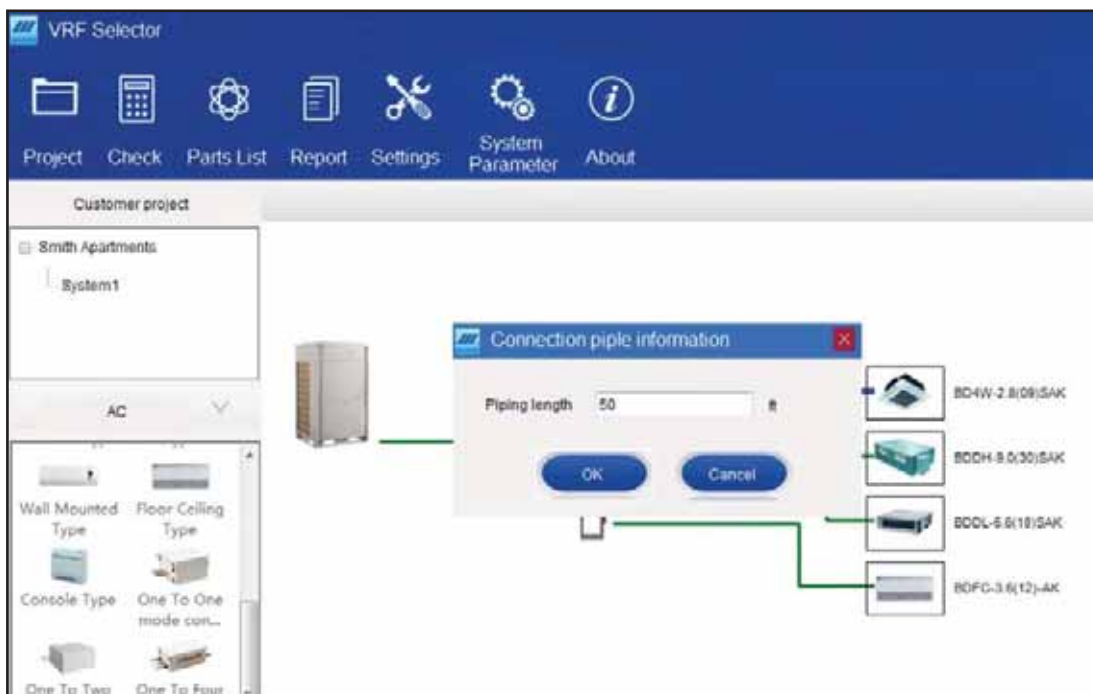

Add Piping Length



# VRF Accessories - Selection Software

## Outdoor Unit Selection

Once you have selected all of your Indoor Units, Y-Branches, Mode Exchange Units, and you have entered your piping lengths, double-click on the outdoor unit. Click "Recommend" and the Selection Software will automatically select the unit best suited for your application. You can also change the desired connection ratio and static pressure for your Outdoor Unit.

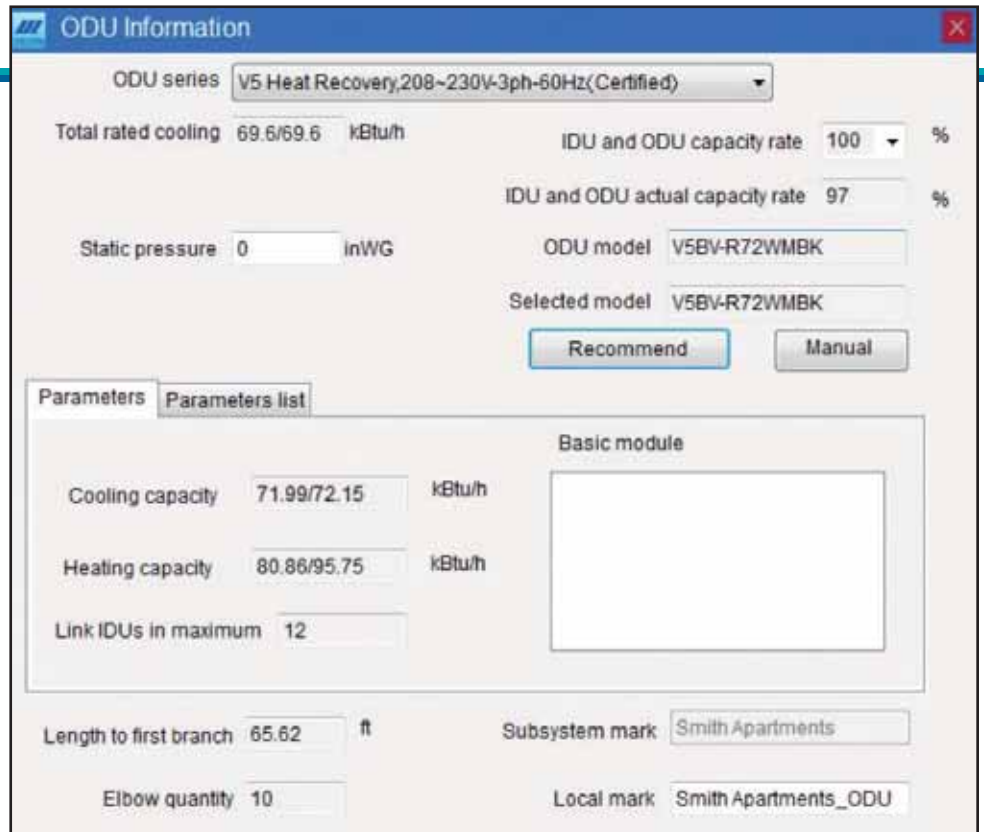

Outdoor Unit Selection 1

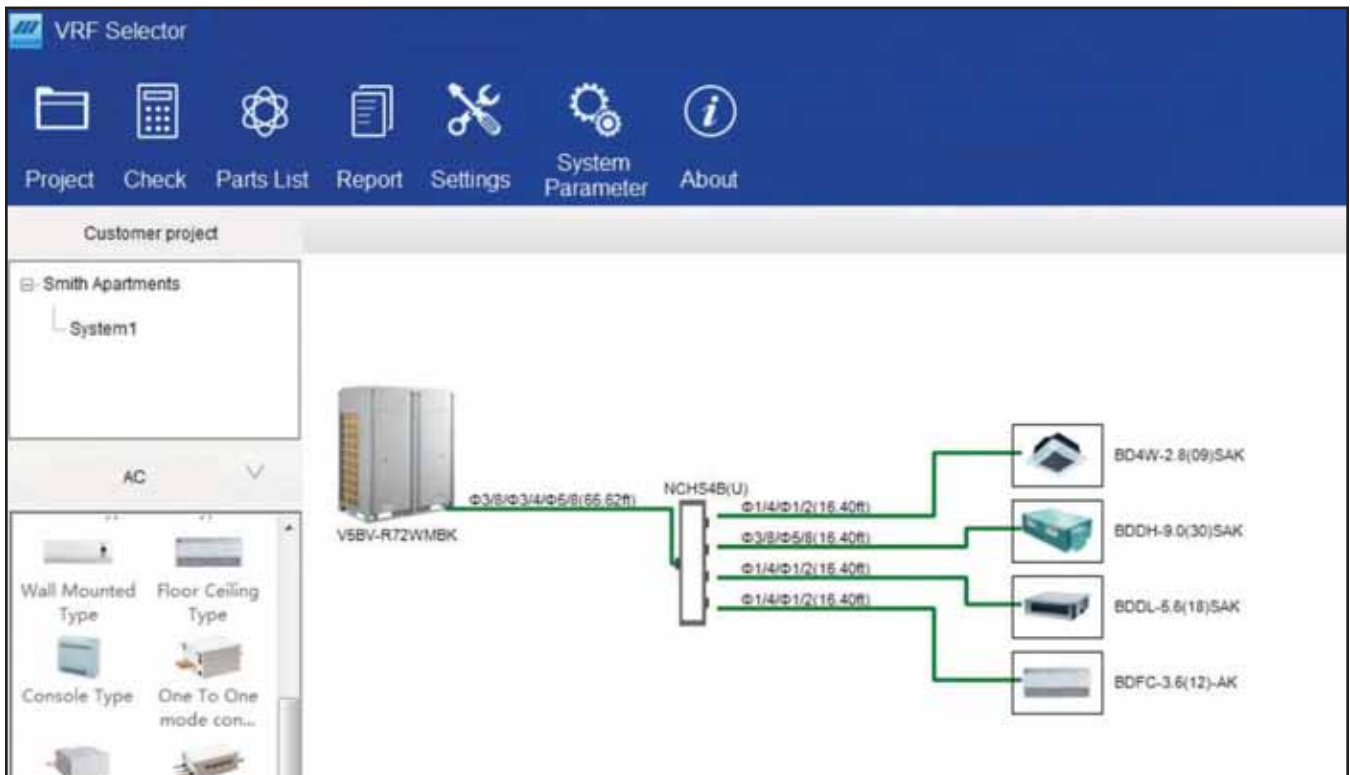

Outdoor Unit Selection 2

# VRF Accessories - Selection Software

## Automatic System Checking and Output

To automatically check for errors, click “Check,” select your system, click “OK,” select “Adjust ODU Only,” click “OK,” and you’ll be prompted with a “Checking Completed” message. If you do have an error or if a change was automatically made, you will be notified and you will not be able to send your customer a report with errors.

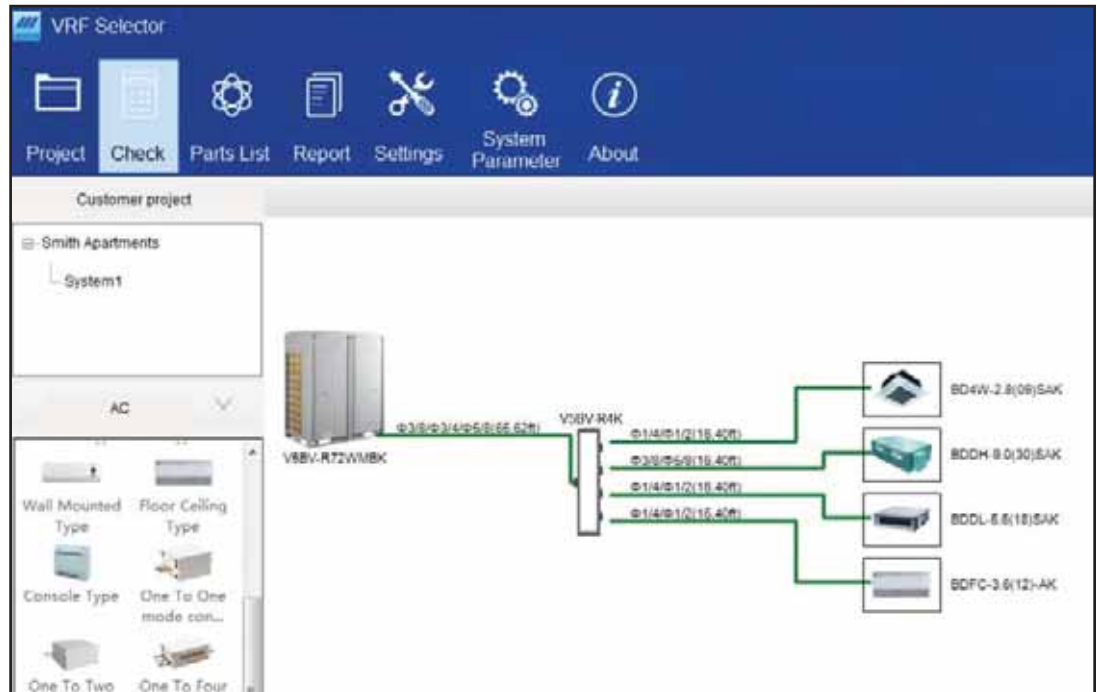

Automatic System Check 1

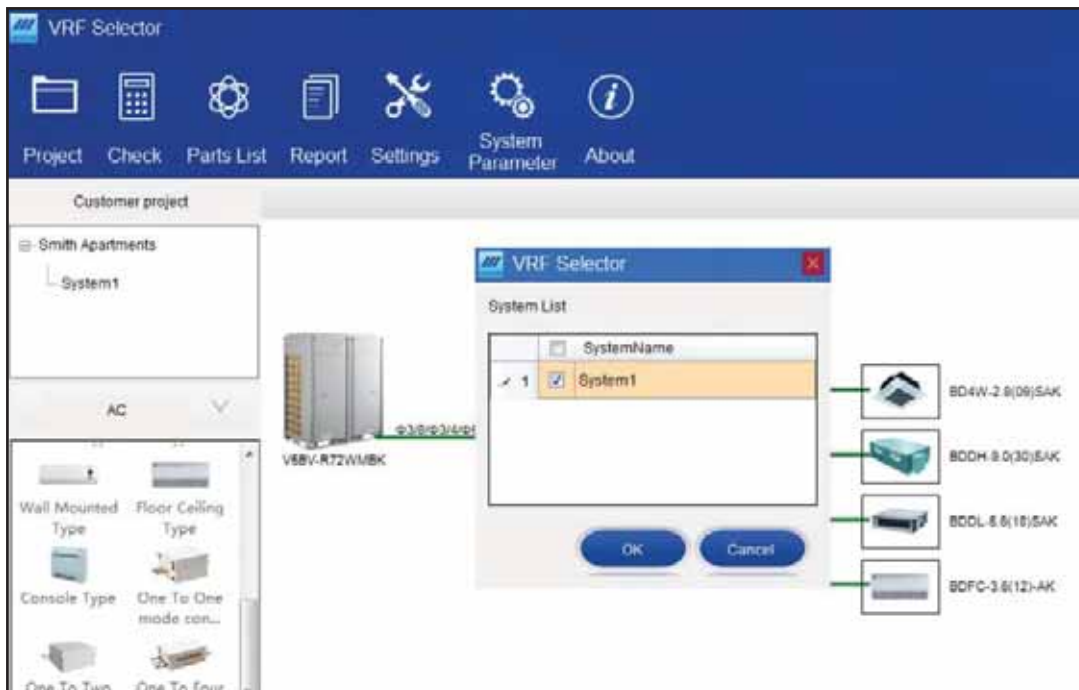

Automatic System Check 2

# VRF Accessories - Selection Software

## Automatic System Checking and Output continued

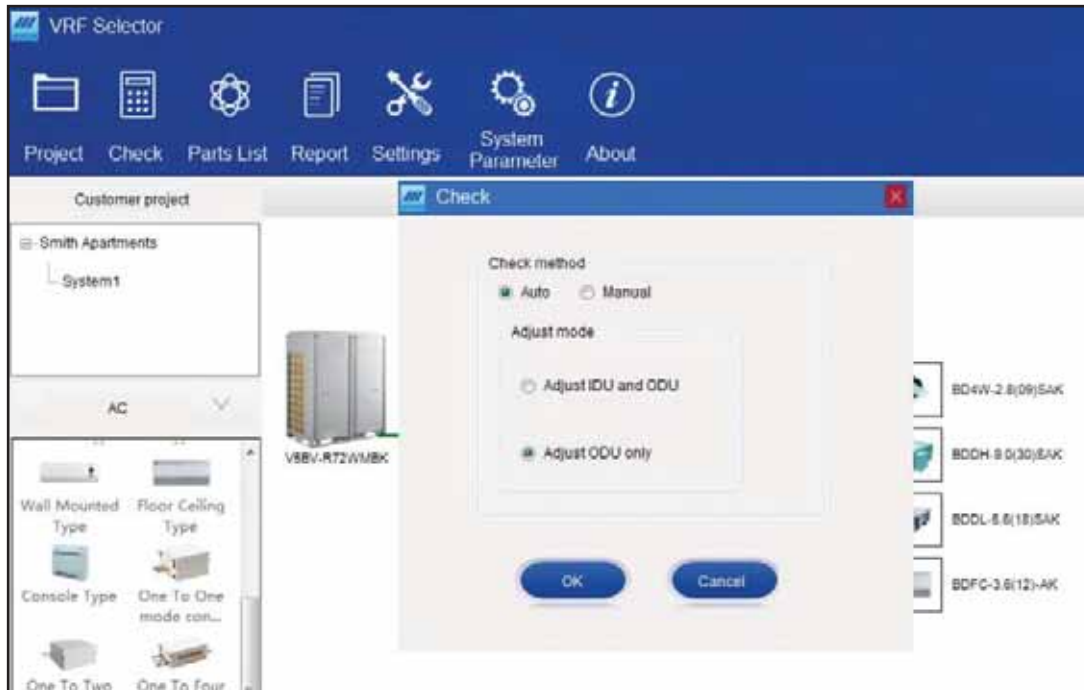

Automatic System Check 3

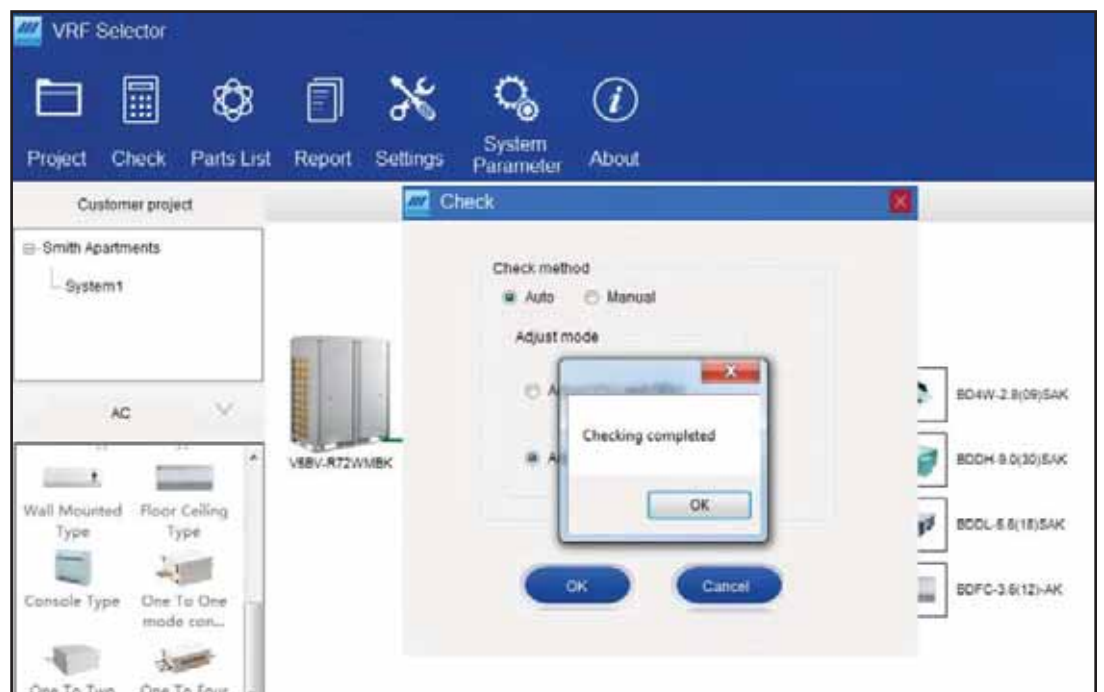

Automatic System Check 4

# VRF Accessories - Selection Software

## Project Output

To output an easy-to-read report for your customer, you'll click report, select your system, and press output. The report is automatically generated, organized into tabs containing all of your project information. This is great for record-keeping and sales quotes. It includes the size and mount of copper tubing you'll need, the amount of refrigerant you'll need, and even includes the piping diagram for the entire system!

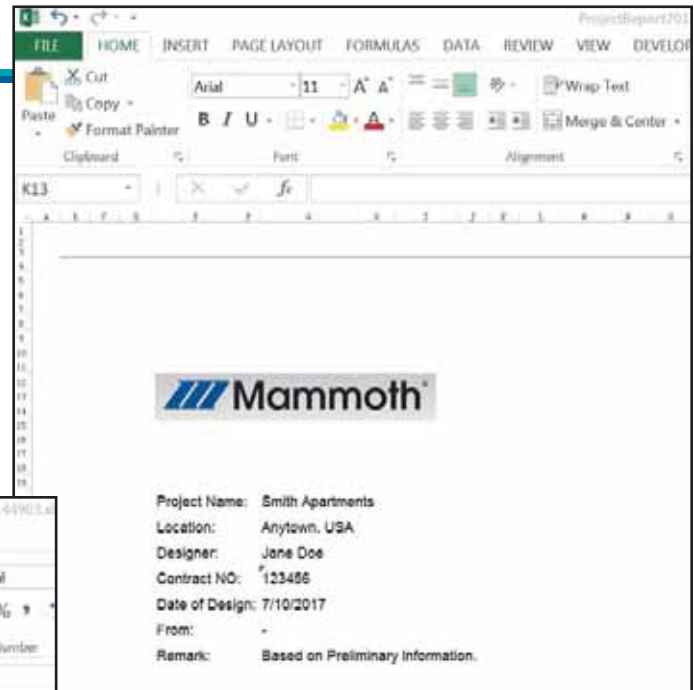

Project Output 1

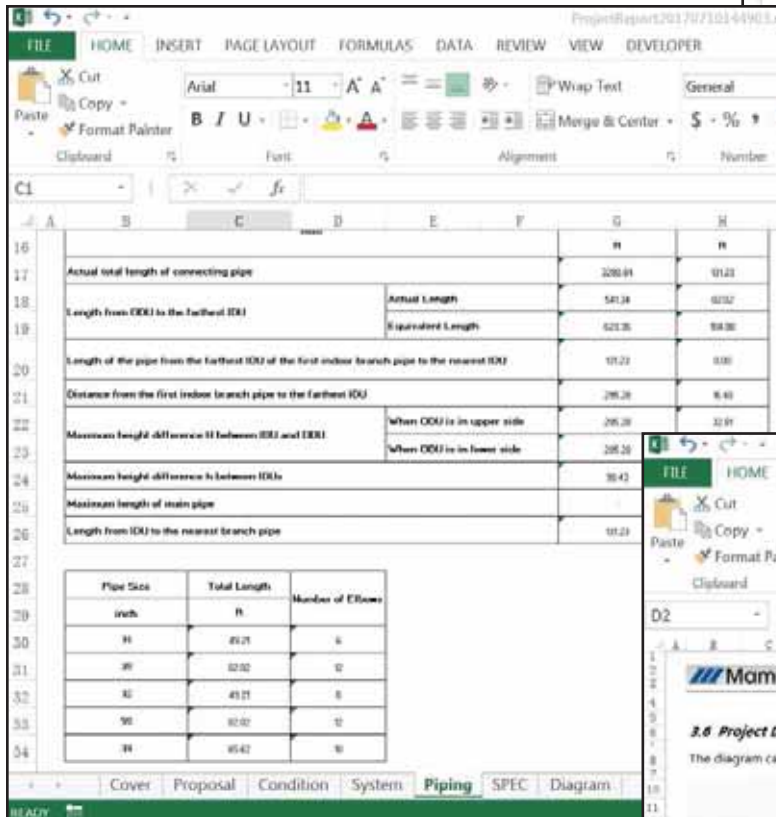

Project Output 2

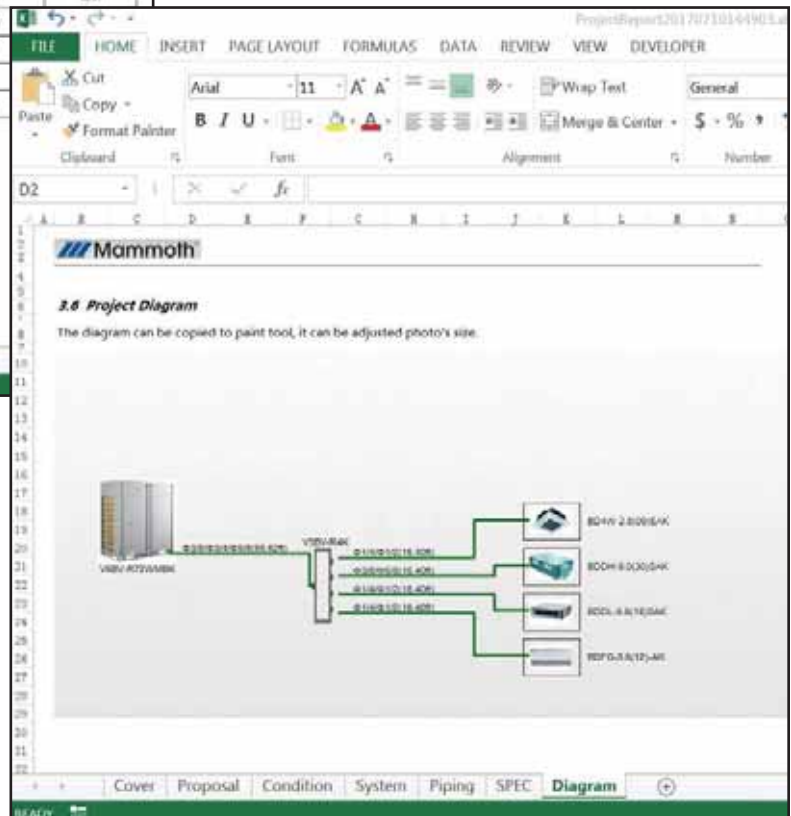

Project Output 3

# VRF Accessories - Fresh Air Processing

## Fresh Air Processing Indoor Unit

Airflow volume: 1150 - 1800cfm

### One System, Two Functions

Adopted with DC inverter technology, Fresh Air DC Inverter Multi VRF System features air conditioning function and fresh air function.



### Applications include:

- Residential houses
- Villas
- Office buildings
- Hotels
- Apartments

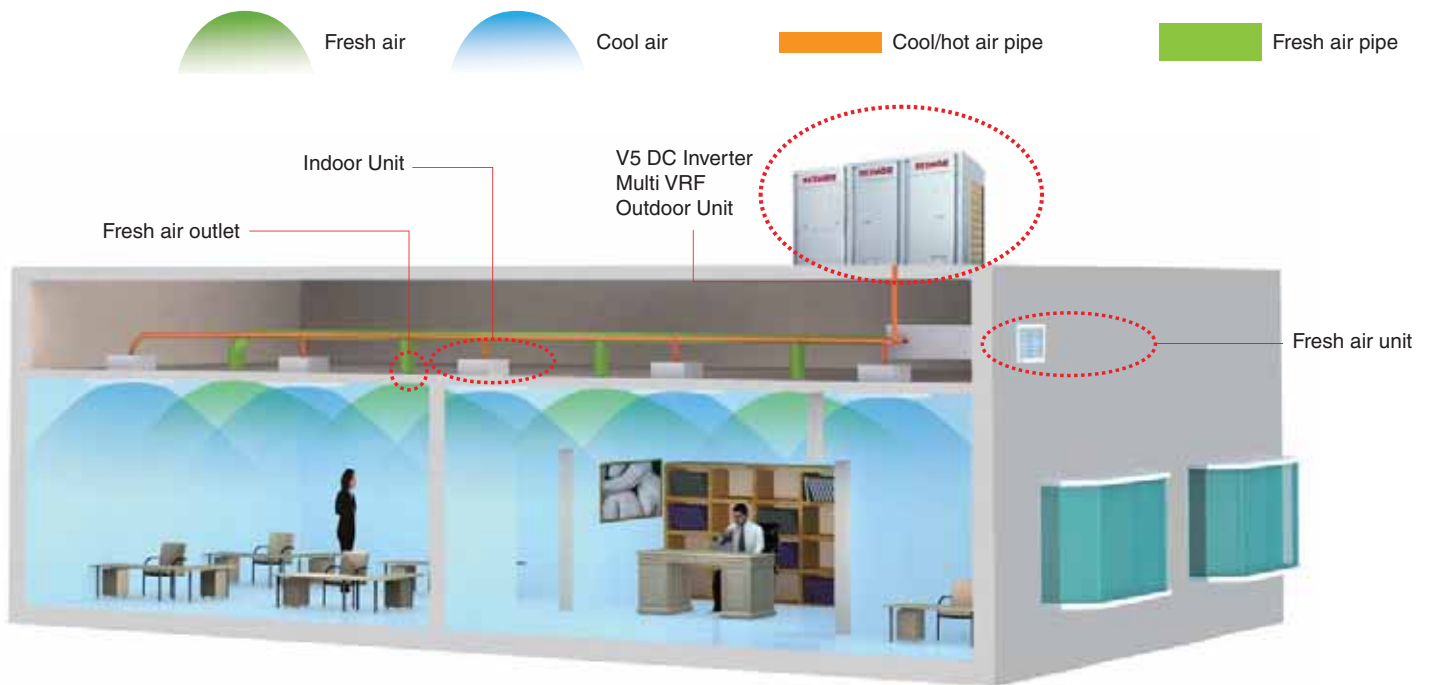

## Enjoy Fresh Air

Airflow volume: 1150 - 1800cfm, cooling capacity: 6 - 8 Tons

Applicable for all types of structures.

Direct evaporative cooling + air conditioning + fresh air can be generated accurately and precisely.

DC inverter technology, constant humidity control with less power consumption.

Integrated system control with Multi VRF System.



# VRF Accessories - Fresh Air Processing

## Air Conditioning and Fresh Air, Two-in-One

### Lower Installation Cost

Fresh Air DC Inverter Multi VRF System can be combined with Mammoth V5. Fresh air unit is roughly equivalent to the cost of V5 + Air exchange fan.

### Lower Operating Cost

Unit can control refrigerant output according to actual needs to ensure constant airflow temperature. By adjusting power output, full load operation can be avoided when only partial load is needed. Thus, operation cost can be greatly reduced.

### Less Installation Space

With the combined connection design less space is required for outdoor units. Ideal for applications where roof area is a premium.



## 6 to 8 Ton - 60 Hz

Model			B DFA-22(72)AK-1150	B DFA-28(96)AK-1800
Capacity	Cooling	MBtu/h	72.0	96.0
		kW	21.1	28.1
	Heating	MBtu/h	55.0	68.0
		kW	16.1	19.9
Power Supply		Ph-V-Hz	1-208/230-60	
Power Consumption		W	740	760
Airflow Volume (H/M/L)		M <sup>3</sup> /Hr	2000	2500
		CFM	1175	1470
MOP		A	10	
ESP		Pa (in. wc)	200 (0.80)	
Sound Pressure		dB(A)	50	51
Connecting Pipe Diameter		Liquid Line	in. (mm) 3/8 (9.52)	
		Suction Line	in. (mm) 3/4 (19.05)	3/4 (22.2)
Drain Pipe		External Diameter	in. (mm) 1 (25)	
		Thickness	inch 3/32	
Outline Dimension		WxDxH	inch 59 x 39-3/8 x 19-5/8	
			mm 1500 x 1000 x 500	
Package Dimension		WxDxH	inch 72-1/2 x 47-1/4 x 26-1/2	
			mm 1840 x 1200 x 673	
Net Weight/Gross Weight		lb	180/229	
		kg	130/182	134/188

# VRF Controls

Mammoth VRF controls come in many different styles to suit any application. Standard controllers include wireless remote and wired controllers. Also available are optional centralized controllers with 32 and 255 unit connection capability, long distance monitoring, BACnet, and Modbus Gateways.



Wired Controllers



Modbus Gateway



BACnet



Wireless Remote

# VRF Controls

## Commissioning Software - Auto Direction of Connection Path

The wiring diagram will direct connection path automatically, so that the user can determine the connection path quickly.

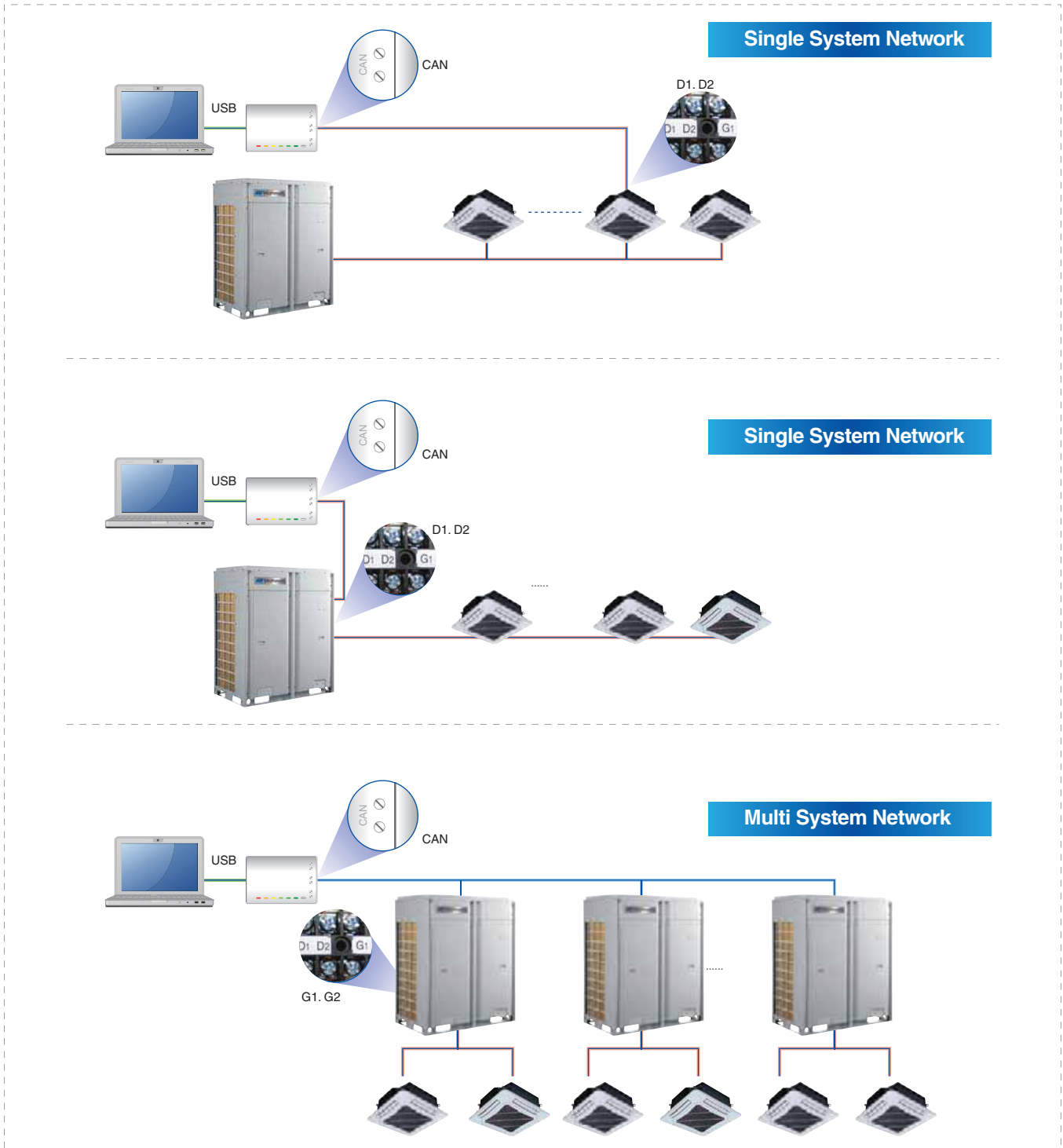



# VRF Controls

## Multiple Intelligent Remote Control Management

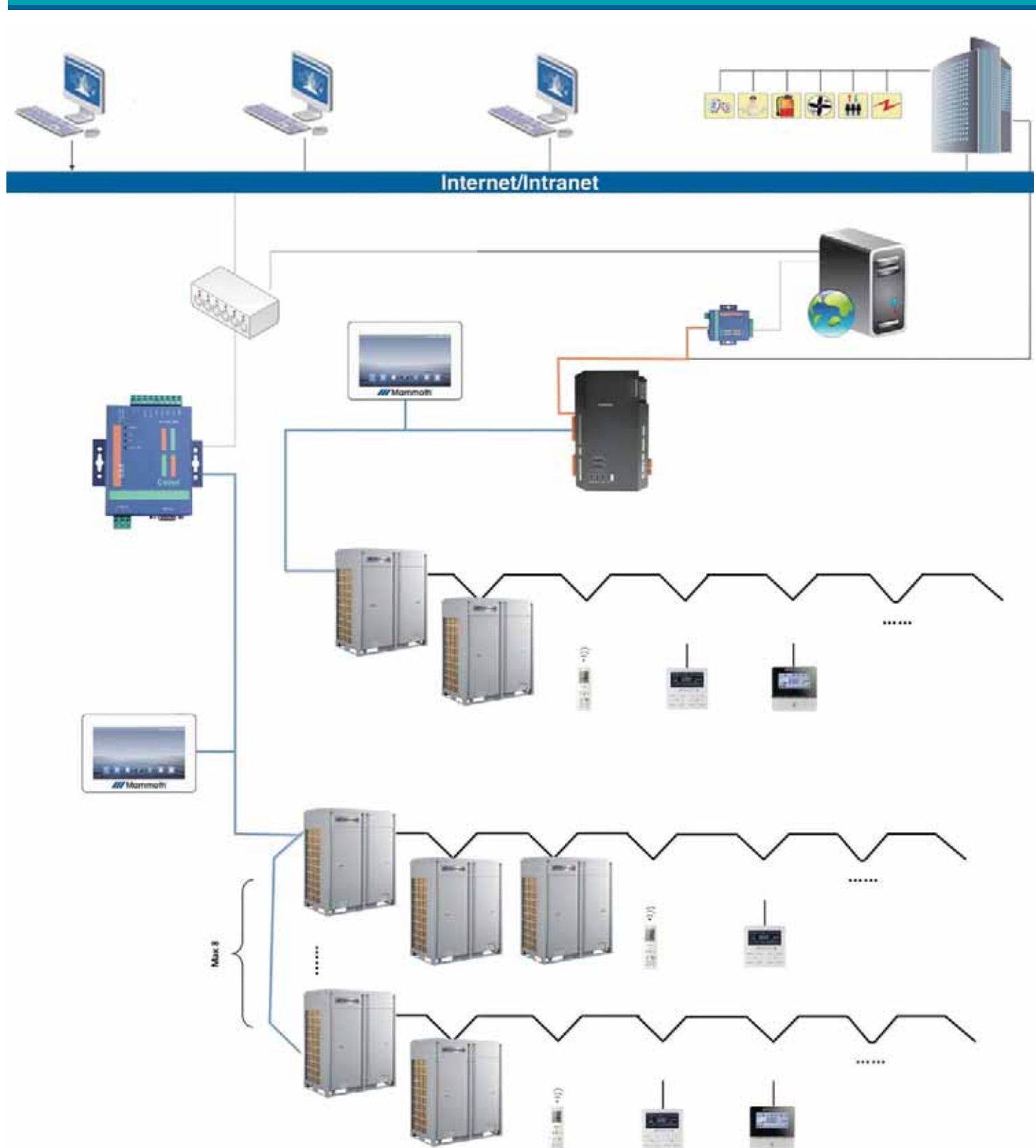

# VRF Controls

## Visualized Management

System provides a map that can display air conditioners' locations in rooms and buildings.



# VRF Controls

System is able to measure the status and number of air conditioners in different levels.

## Everyday Management

### Setting for Daily Operation

- a. Management in days/weeks/months/years
- b. Management in each unit
- c. Simple display for management

### Everyday Management at Different Locations

- a. Management for overtime hours
- b. Management for meal breaks
- c. Management for normal working hours

### Other Functions

- a. Power on/off, modes, humidity, fan speed
- b. Auto shut-off can help prevent waste of energy that may be caused by forgetting to turn off the air conditioner

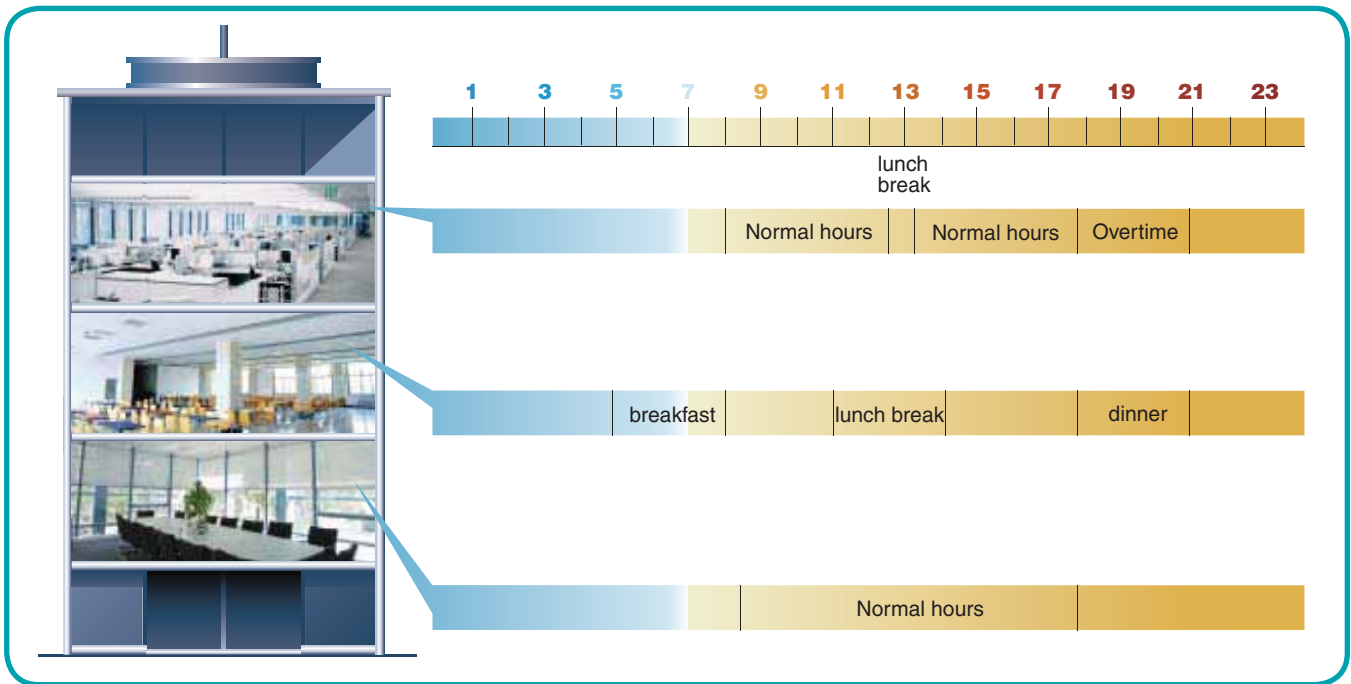

## Group Management

### Central Management in Groups

- a. Free choices of dividing groups
- b. Central control over power on/off
- c. Central control over temperature
- d. Central control over modes
- e. Central control over user authority



# VRF Controls

## Authority Management

### Only for Indoor Units

- a. Limited control over power on/off
- b. Limited control over temperature
- c. Limited control over modes



**Allows managers to limit employee access**

## Statistical Analysis

### Recording Statistics

System can self generate graphs of statistics for easy management and analysis.

### Recording Errors

System can show the information of errors in charts and send alarms of errors through emails.

### Recording Operation

System can record users' daily operation.

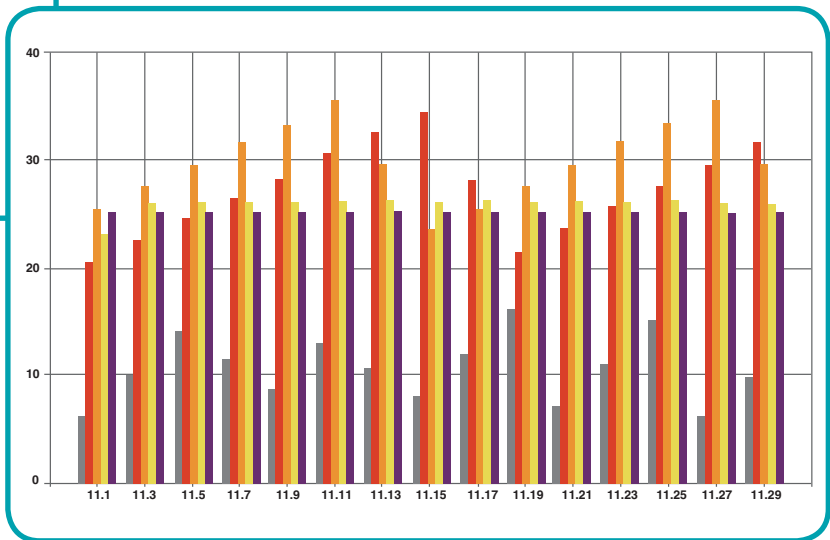
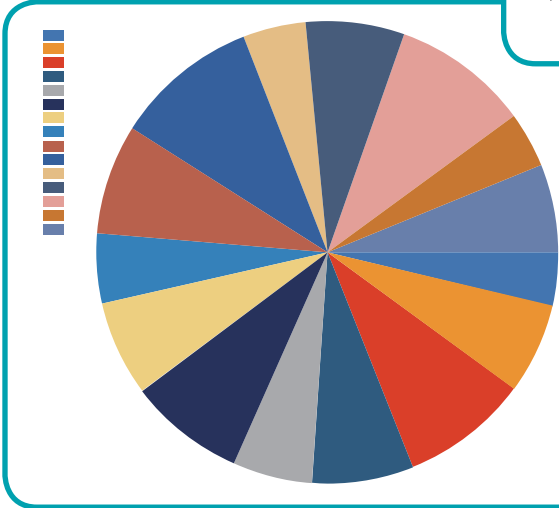
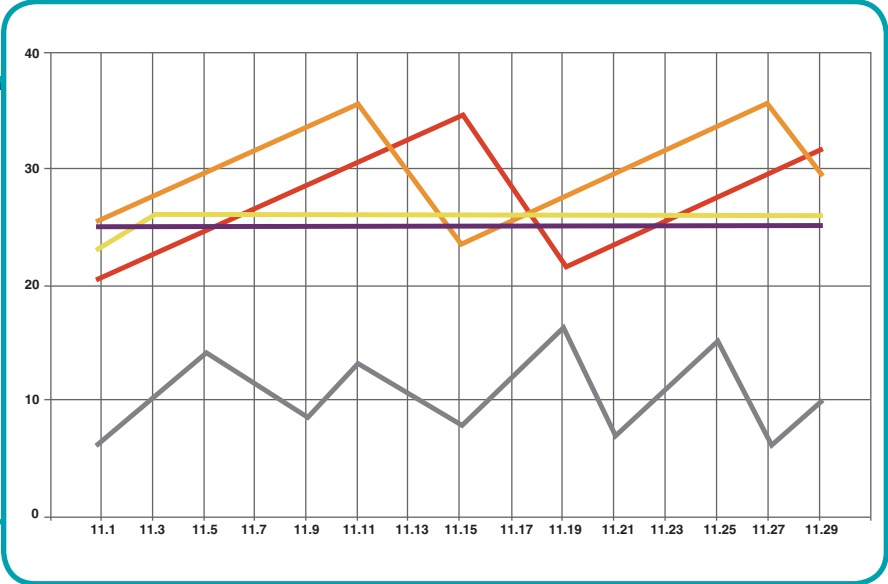

# VRF Controls - Debugging Software

## Intelligent Debugging Software

V5 offers intelligent debugging software to the end-user to assist in commissioning the system at a fraction of the cost of our competitors' service tool.

### Monitoring Functions

- Fully control the operational status of each device of the system
- Hover the mouse over the parameter to display its remarks
- The online devices will be displayed in a tree structure
- Display the information of air conditioner in divided regions
- Each display region can be moved or concealed
- Display updated status of units in real time

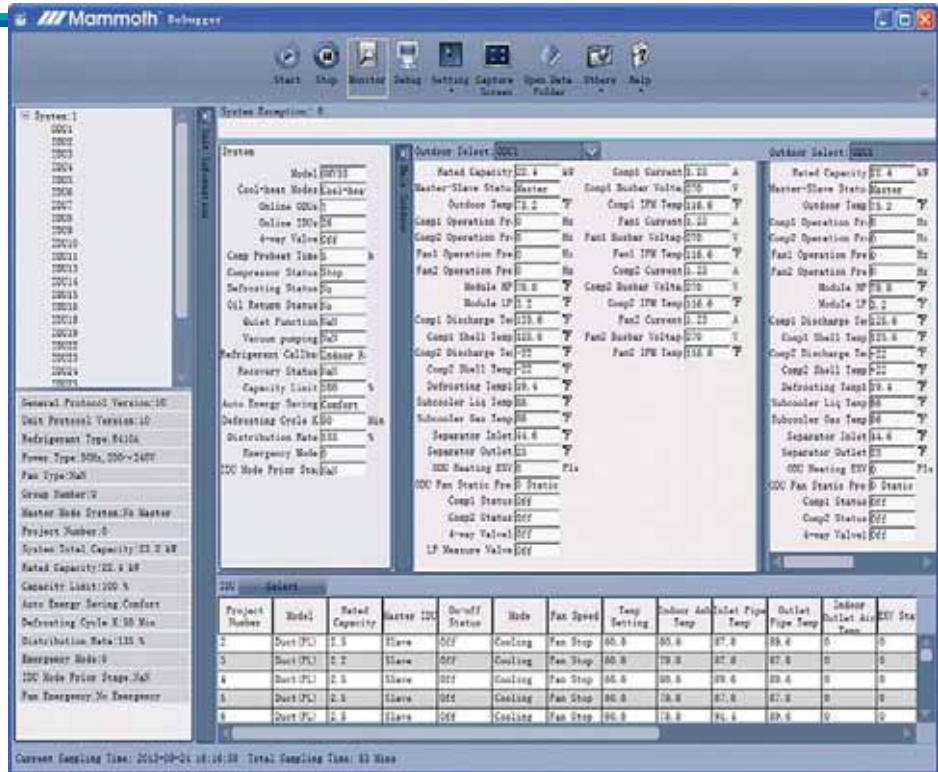

### Control Functions

- Control the operation of unit to suit your needs
- Comprehensive control of outdoor unit, indoor unit, etc.
- Real-time display of current status or status after being controlled
- Both single control and group control are available

### Project Debugging Functions

- One-click and automatic project debugging
- Project debugging is arranged step by step from left to right

Manual intervention and bypassing of some debugging phases are available.

Green icons will be displayed for the items finishing debugging; red icons will be displayed for the items having debug exceptions; light yellow icons display debugging information.

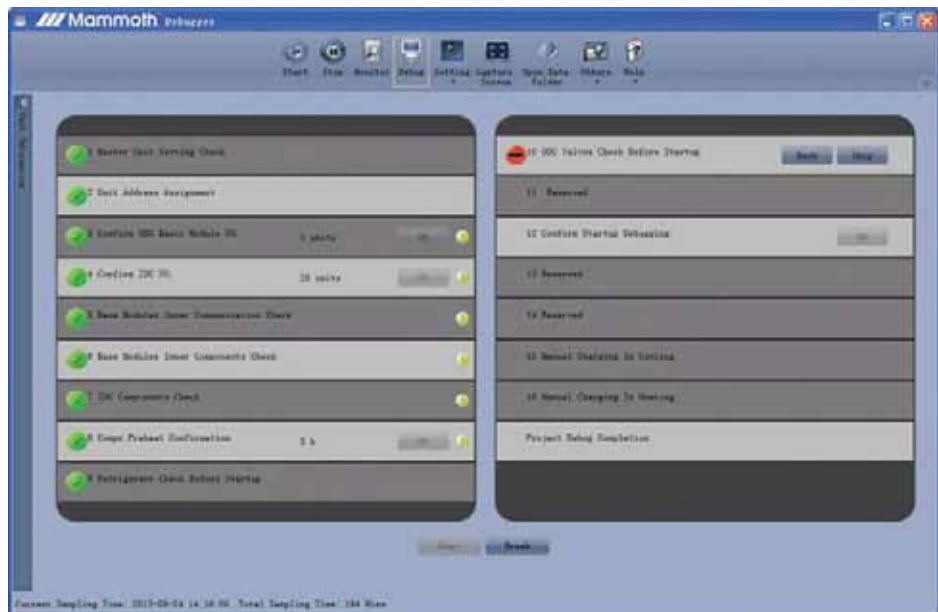

# VRF Controls - Debugging Software

## Intelligent Debugging Software (continued)

### Auto Data-Saving Function

Data will be saved automatically. Database saving path can be changed or data document can be generated repeatedly.



Step 1: Change Database Saving Path

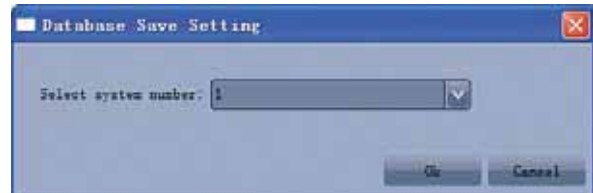

Step 2: Database Save Setting

### USB Data Converter

Users can use a USB data converter to freely convert CAN/HBS/RS485 data into USB data, achieving data interchange between computer and the air conditioner.

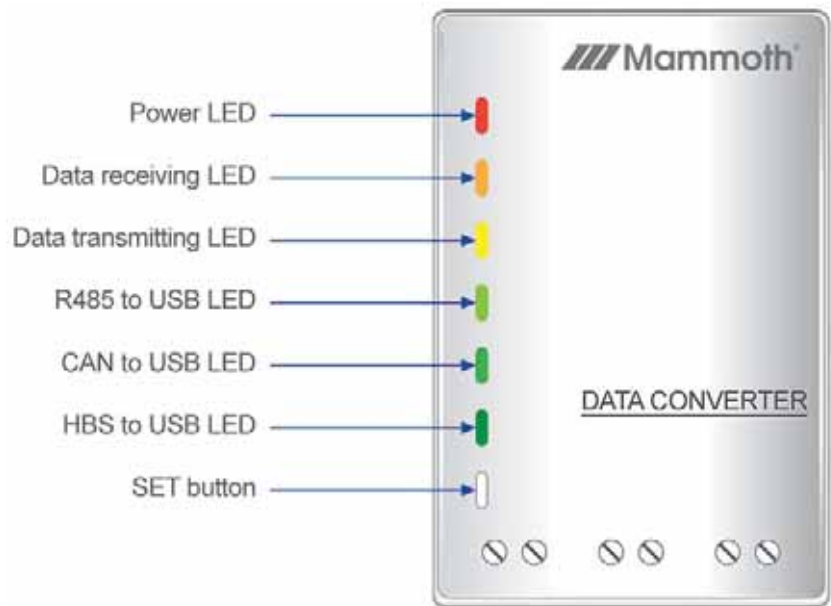

# VRF Controls

## Calculating Cost of Electricity

### Auto Calculation according to Users

- a. According to the operating time, modes, flow of refrigerant, humidity and other factors, system can calculate the cost of electricity for users in different locations.
- b. Detailed information of bills and operation data can be provided.

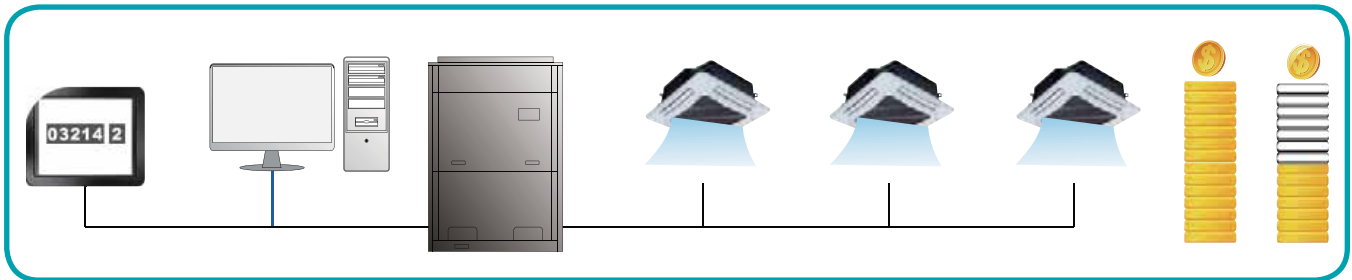

## Energy Management

### Analysis of Energy Cost

- a. Air conditioners that use excess energy
- b. Air conditioners that are set too low
- c. Air conditioners with poor cooling performance

### Ways to Save Energy based on the following Aspects:

- a. Operating time
- b. Unit turned on too early
- c. Unit turned off too late
- d. Comfort
- e. Cost of electricity/cost of electricity per square meter

## Energy saving

### Limits on Electricity

- a. Analysis on the cost of electricity
- b. Set the maximum cost of electricity and unit will operate within set limits
- c. System can show users the cost of electricity during operation and give suggestions on energy saving.

### Economic Operation

System is able to operate in selectable energy-saving conditions.



## VIP Management

System can provide independent and unique service to VIP users.



# VRF Controls

There are two kinds of controllers: wired controller and remote controller. The system provides various controls for users, such as cooling, heating, dehumidifying and fan etc., giving users maximum flexibility according to their own using needs.

## Wired Remote Controller WRC1

(standard version for ducted indoor unit type, optional version for cassette & high wall indoor unit type)

- LCD with black background and white words; touch buttons
- Clock can be displayed; 24 hour timer setting for on/off
- 7 levels of fan speed, up & down swing and left & right swing
- Can be switched in auto, cooling, dehumidifying, fan, heating, floor heating, 3D heating and space heating operation modes
- Master and slave wired controllers can be set; simultaneous control over several indoor units is available. Up to 16 indoor units can be controlled. If error occurs in these units, the controller can have the affected indoor unit produce an audible tone for easy identification.
- Available functions: sleep, ventilation, quiet/auto quiet, light, energy saving, auxiliary heating, drying, memory, low-temperature dehumidifying, absence in heating, controllable auxiliary heating in dehumidifying, filter cleaning reminder, etc.
- Detect ambient temperature; receive infrared remote controller signal
- With project parameters viewing and setting functions



## Wired Controller (special order for hotel)

- With simplified functions, mechanical buttons, backlit LCD and convenient operation
- Can be switched in auto, cooling, dehumidifying, fan and heating operation modes
- Master and slave wired controllers can be set; simultaneous control over several indoor units is available
- Detect ambient temperature; receive infrared remote controller signal
- With system parameters viewing and setting functions
- 7 levels of fan speed, up & down swing
- Door control system can be connected



## Wireless Remote Controller RC

(standard version for cassette indoor unit & high wall indoor unit, optional version for ducted indoor unit)

- Can be switched in auto, cooling, dehumidifying, fan and heating operation modes
- 6 levels of fan speed including Turbo Fan
- Available functions: child lock, drying, health, ventilation, turbo, sleep, light, absence, IFeel, and timer
- Clock display and indoor/outdoor ambient temperature viewing functions
- Up & down swing and left & right swing





# VRF Controls

## Remote Controller (special order)

- Can be switched in auto, cooling, dehumidifying, fan, heating, floor heating, 3D heating and space heating operation modes
- 7 levels of fan speed, up & down swing and left & right swing
- Available functions: child lock, energy saving, drying, health, ventilation, quiet/auto quiet, sleep, light, absence, low-temperature dehumidifying, IFeel, and timer
- With clock display, system parameters viewing and setting functions



## Wired Controller

- Elegant appearance
- High-resolution color LCD
- Capacitive touch control; receive infrared remote controller signal
- Various timing functions: three weekly timers and one countdown timer can be set simultaneously; mode, temperature and fan speed can be preset in weekly timer
- Complete system functions; each function will be implemented in an individual page with interactive and humanized interface
- Various personalized functions, e.g. setting brightness and backlight time
- Sufficient viewing functions, e.g. viewing on/off status and after-sales service hot line



# VRF Controls

## Single Control of One Unit

Each indoor unit has an independent controller.

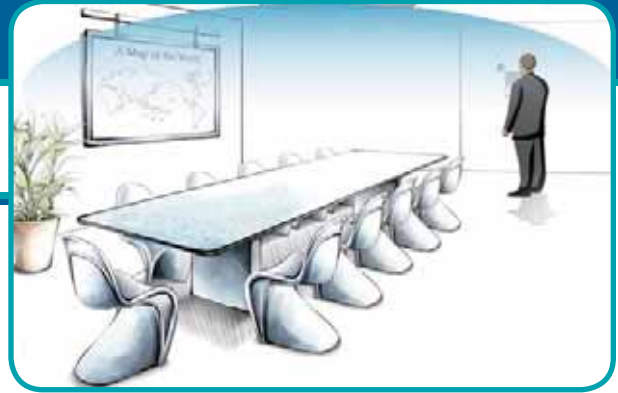

## Multiple Control of One Unit

One indoor unit can be controlled by two wired controllers at different places.

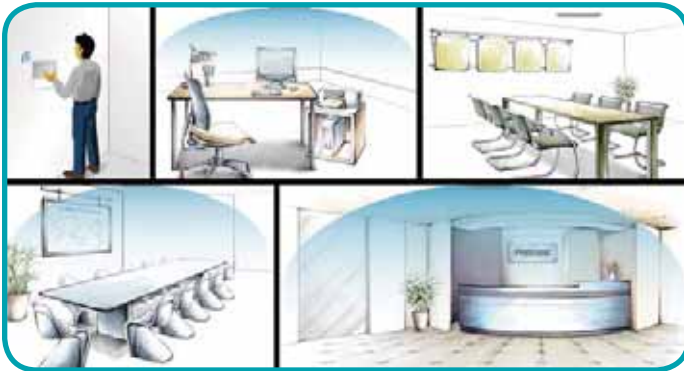
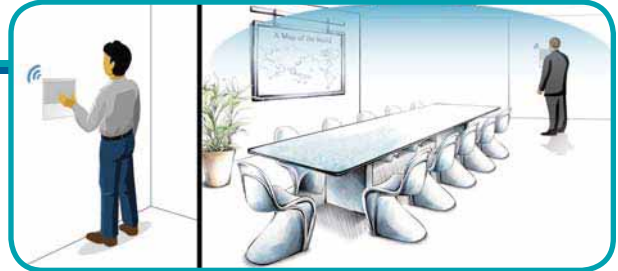

## Central Control of Several Indoor Units

One wired controller can control as many as 16 indoor units.

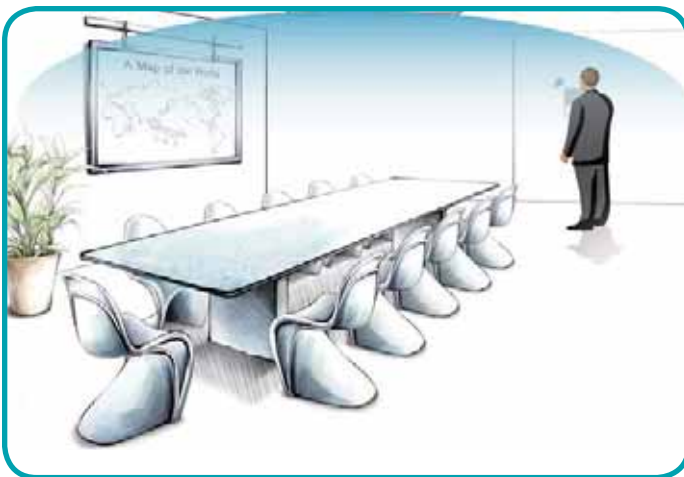

## Joint Control of Remote Controller and Wired Controller

Users can control one unit with two types of controllers: a remote controller which is convenient and flexible; or a wired controller which includes every function of an air conditioner.

Two wired controllers can control a group of 16 indoor units. Used in very large spaces.

The temperature sensor used for temperature detection can be designated.

# VRF Controls

## Central Controller Smart Zone Controller CC-32

- 1280\*800 high-resolution color LCD
- 7" capacitive touch screen for easy operation
- Shielding function of single unit, group and all indoor units (shielding on/off, mode, temp setting, etc.) "Shielding" prevents a user from changing certain functions as designated by the Central Controller.
- With various functions: centralized control (control all indoor units), group management (support DIY grouping), schedule management (setting of several schedules) and single unit control (on/off, mode, temp setting, fan speed, quiet, swing control, etc.)
- Provide naming of indoor units, selection of icons and personalized settings (setting background, backlight, etc.)
- Up to 32 indoor units can be centrally controlled
- Elegant and fashionable appearance
- Embedded installation in wall with projecting thickness only of 7/16 inch
- Connectable with network of indoor units or outdoor units
- Independent power supply in 110~240V wide voltage range
- With project setting, parameter viewing, malfunction record and access management functions



## Central Controller CC-255

- 1280\*800 high-resolution color LCD
- 7" capacitive touch screen for easy operation
- With project setting, parameter viewing, malfunction record and access management functions
- With various functions: centralized control (control all indoor units), group management (support DIY grouping), schedule management (setting of several schedules) and single unit control (on/off, mode, temp setting, fan speed, quiet, swing control, etc.)
- Shielding function of single unit, group and all indoor Units (shielding on/off, mode, temp setting, etc.)
- Provide naming of indoor units, selection of icons and personalized settings (setting background, backlight, etc.)
- Up to 255 indoor units can be centrally controlled
- Elegant and fashionable appearance
- Embedded installation in wall with projecting thickness only of 7/16 inch
- Connectable with network of indoor units or outdoor units
- Independent power supply in 110~240V wide voltage range



# VRF Controls

## BACnet Gateway BAC-G

BACnet gateway kits MG30-24/D2(B) are intended to realize the data exchange between the air conditioning unit and BAS, and providing the standard BACnet/IP building interface and 8 I/O interfaces, one of which is the fire alarm signal interface. The status of the other 7 I/O interfaces is mapped to the specific objects of the BACnet/IP bus and can be defined by the user.

**Applicable models:** V5 All DC Inverter Multi VRF System.



- International standard BACnet/IP interface, which has passed BTL certification;
- Real-time monitoring of unit operation status, e.g. on/off, mode, temperature;
- Real-time response to the control of unit (on/off, mode setting and speed setting, etc.) by monitoring software;
- Monitor unit errors;
- Lock unit operation statuses, directing at all control functions of unit itself or a certain setting function;
- Achieve cooling and heating temperature limitation functions;
- 8 DI/DO interfaces for receiving fire alarm signal and user's definition logic;
- Large storage capacity of unit operation data for up to 6 months.

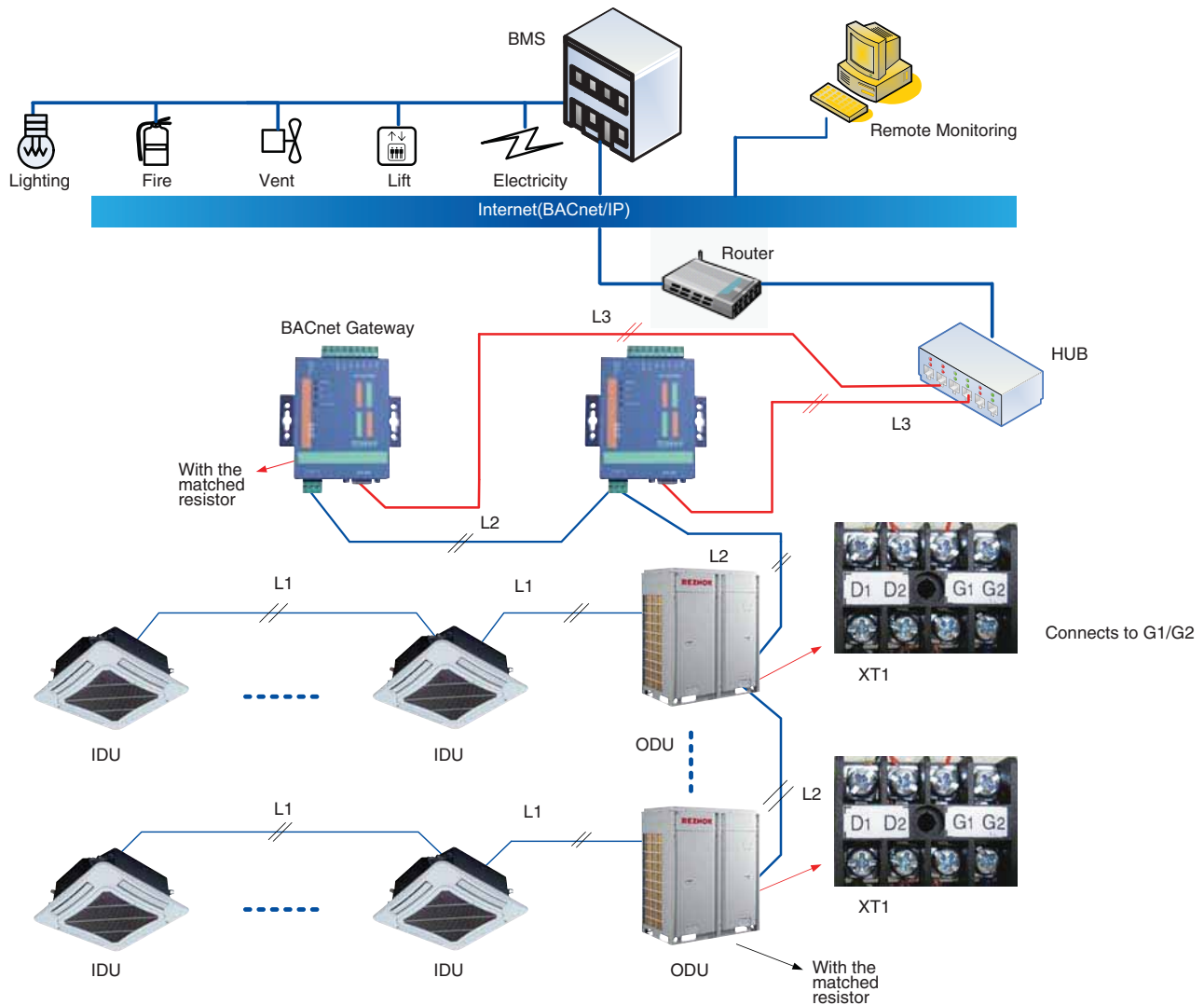

# VRF Controls

## Modbus Gateway (Long Distance Monitoring Software requires the ModBus Gateway)

Modbus Gateway provides V5 system with the Modbus protocol interface when connecting to the Building Management System(BMS) in order to achieve central control and remote control over V5 system by BMS.

**Applicable models:** V5 All DC Inverter Multi VRF System.

- Real-time monitoring of unit operation status, e.g. on/off, mode, temperature
- Real-time response to the control of unit (on/off, mode setting and speed setting, etc.) by monitoring software
- Control all the units switches of on and off
- Monitor unit errors
- One Modbus bus can support up to 255 gateways. One Modbus gateway can support at most 16 outdoor units (up to 64 modular outdoor units) and 128 indoor units
- Lock unit operation statuses, directing at all control functions of unit itself or a certain setting function
- Linkage control, supporting 5 DI and 5 DO for receiving fire alarm signal and user's definition logic
- CAN, RS485 communication ports are non-polar, convenient for construction wiring
- Achieve cooling and heating temperature limitation functions
- 100-240 VAC,50/60Hz wide voltage range, adapted to the power supply of each country and region

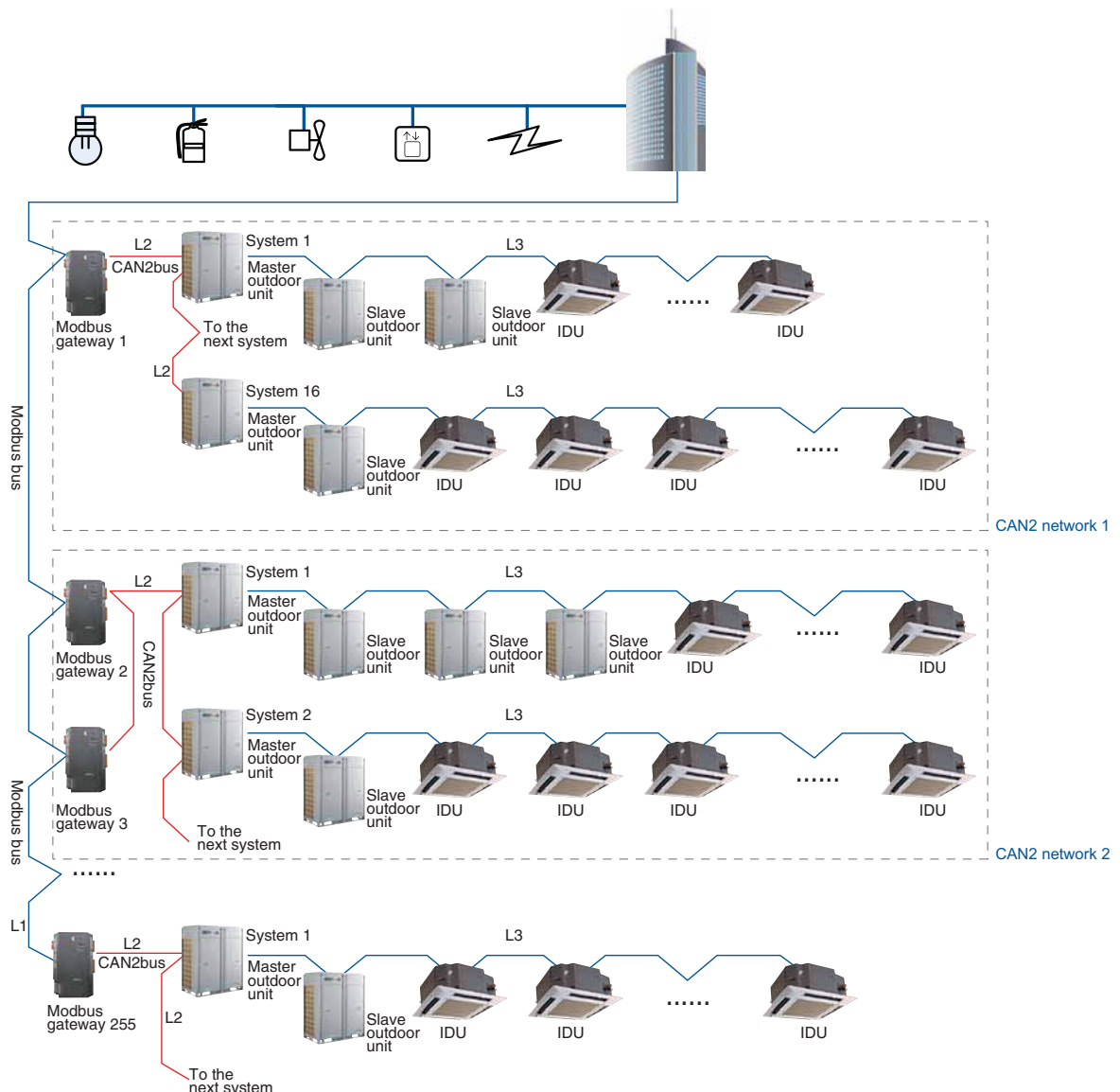

# VRF Controls

## Control System Lineup

Controlling System		Product Series	Cassette Type	High ESP, Low ESP, Slim Ducted Duct Type	Fresh Air Processing	Wall Mounted Type	Floor Ceiling Type	Console Type
Wireless Remote Controller		RC		●	●	●	●	●
Wired Remote Controller	Wired Controller	WRC1		●	●	●	●	●
	Wired Receiver	WRC-RD		●	●			
Centralized Controller	Central Controller	CC-255		●	●	●	●	●
	Smart Zone Controller	CC-32		●	●	●	●	●
Kit for Commissioning Software		COM-S		●	●	●	●	●
Long-Distance Monitoring Software		LDM-S		●	●	●	●	●
Gateway of Modbus		MOD-G		●	●	●	●	●
Modbus BACnet Gateway		BAC-G		●	●	●	●	●

Note: ● standard ● optional

# Notes

---



# Standing behind your Investment

Mammoth variable refrigerant flow (VRF) multi-zone systems offer a 5-Year limited parts warranty. Compressors carry a 7-Year warranty. To learn more about our product warranties, ask your Mammoth contractor.



ISO 9001 Quality System Certificate



ISO 14001 Environmental Management System Certificate



ISO 18001 Occupation Healthy Safety System Certificate



Canadian & American CSA Certificate



CQC Certificate



3C Certificate



American UL Certificate



American and Canadian ETL Certificate



EQM Certificate



SASO Certificate



ENERGY STAR Partner Certificate



AHRI 210-240 Air Conditioner Certificate



AHRI 210-240 Heat Pump Certificate



AHRI 1230 Air Conditioner and Heat Pump Certificate



Specifications and illustrations subject to change without notice and without incurring obligation. All trademarks are the property of their respective organizations.

Trademark Mammoth® used under license. © Nortek Global HVAC, LLC 2017. All Rights Reserved.