

SUBMITTAL DATA SHEET

DHX24NWB21S **24,000 BTU/H Wall Mounted Heat Pump System**

Job Name:		Location:	
Purchaser:		Order No.:	
Engineer:			
Submitted To:	For:	Ref:	Approval:
Submitted By:		Date:	
Unit Designation:		Schedule No.:	Model No.:

FEATURES

- Compact and Quiet Design
- 4 Indoor Fan Speeds
- Vertical Swing Louver
- Wireless Remote with LCD Display



DHX24NWB21S

ACCESSORIES

- Wired Controller DWUNI
- Wired Controller DWCPX2
- Wi-Fi Module CS532AH



Indoor Model number		DHX24NWB21S
System Type		Heat Pump
Nominal Capacity - Cooling	Btu/h	22,000
Nominal Capacity - Heating	Btu/h	23,000
Rated Voltage	V-Ph-Hz	208/230-1-60
Airflow High to Low	CFM	706/647/588/530
Sound Pressure Level High to Low	dB(A)	48/44/40/36
Piping Connection - Liquid (O.D.)	in.	1/4
Piping Connection - Gas (O.D.)	in.	5/8

Indoor Unit Dimensions

Units: inch

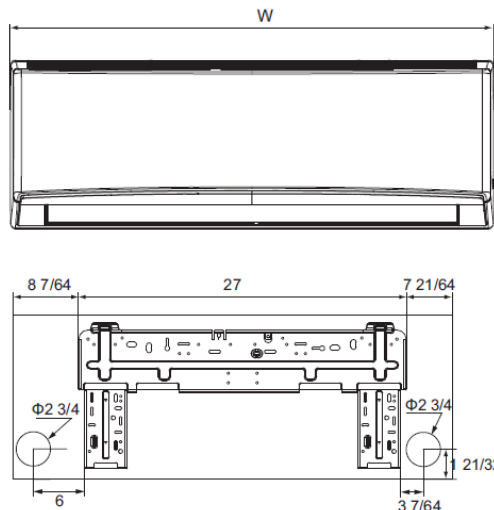

Dimensions	
W	42 $\frac{7}{16}$
H	12 $\frac{51}{64}$
D	9 $\frac{11}{16}$

Drain Connector	5/8-in OD
-----------------	-----------