



SL18XC1
DAVE LENNOX SIGNATURE® COLLECTION
R-410A - SilentComfort™ Technology

RESIDENTIAL
PRODUCT SPECIFICATIONS

Bulletin No. 210836
 October 2020
 Supersedes May 2020



So simple. So smart. So comfortable.



SEER up to 18.50
2 to 5 Tons

Cooling Capacity - 22,400 to 58,000 Btuh

MODEL NUMBER IDENTIFICATION

SL 18 X C 1 - 036 - 230 A 01

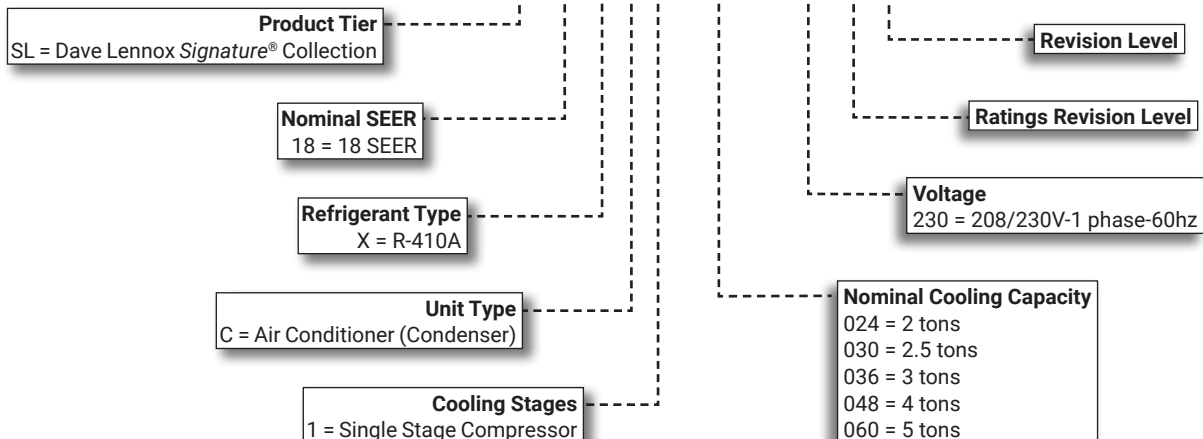

FEATURE HIGHLIGHTS

1. Condenser Fan with SilentComfort™ Technology
2. Quantum™ Coil
3. High Pressure Switch
4. Low Pressure Switch
5. Hi-Capacity Liquid Line Drier
6. Scroll Compressor
7. Compressor Sound Dampening System
8. iComfort® Communicating Control
9. Heavy Gauge Steel Cabinet
10. SmartHinge™ Louvered Coil Protection
11. Refrigerant Line Connections, Electrical Inlets and Service Valves

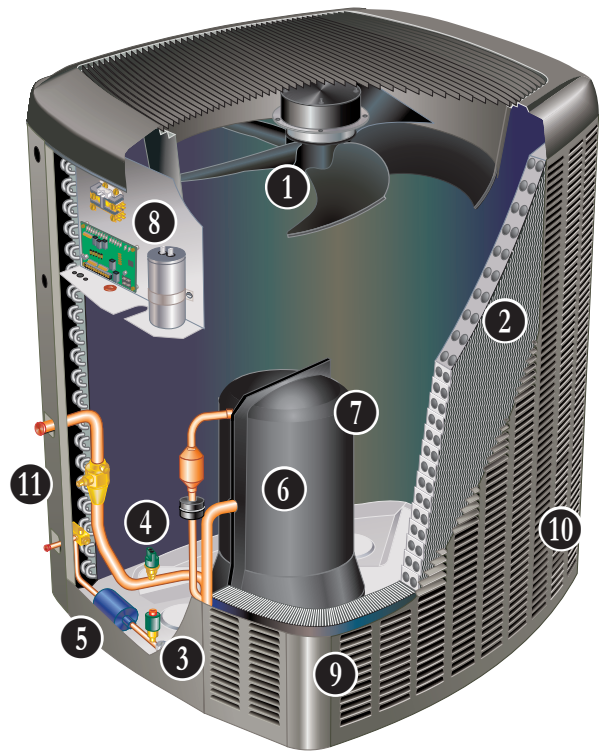

CONTENTS

Approvals And Warranty	3
Dimensions - Unit	9
Electrical Data	7
Features	3
Field Wiring	8
Installation Clearances	8
Optional Accessories - Order Separately	7
Sound Data	8
Specifications	7
TXV Substitution	10
TXV Usage.	10

APPROVALS AND WARRANTY

APPROVALS

- AHRI Standard 210/240 certified
- AHRI Certified system match-ups and expanded ratings, visit www.LennoxPros.com
- ENERGY STAR® Certified (certain units)
- Sound rated to AHRI Standard 270-2008 test conditions
- Tested in Lennox' Research Laboratory environmental test room
- Rated According to U.S. Department of Energy (DOE) test procedures
- Region specific models meet the minimum efficiency requirements for U.S. DOE Federal Regional Standards in that area
- Unit and components ETL, NEC and CEC bonded for grounding to meet safety standards for servicing
- ETL certified (U.S. and Canada)
- ISO 9001 Registered Manufacturing Quality System

WARRANTY

- Compressor:
 - Limited ten years in residential installations
 - Limited five years in non-residential installations
- **All other covered components:**
 - Limited ten years in residential installations
 - Limited one year in non-residential installations

NOTE - Refer to Lennox Equipment Limited Warranty certificate included with unit for specific details.

FEATURES

APPLICATIONS

- 2 through 5 ton
- Sound levels as low as 65 dBA
- Single phase power supply
- Applicable to indoor air handlers or gas furnaces with indoor add-on coils
- Shipped completely factory assembled, piped, and wired

REFRIGERATION SYSTEM

R-410A Refrigerant

- Non-chlorine
- Ozone-friendly
- Unit is factory pre-charged

1 Condenser Fan with SilentComfort™ Technology

- Specially-designed, SilentComfort fan guard
- Passive Vortex Suppression reduces air noise
- Corrosion-resistant PVC (polyvinyl chloride) coated steel wire
- Specially designed fan blades reduce operating sound levels
- Direct drive fan
- Vertical air discharge
- Inherently protected
- Motor totally fan motor

2 Quantum™ Coil

- Lennox designed and fabricated coil
- Enhanced aluminum alloy tube/enhanced fin coil
- Superior corrosion resistance
- Ripple-edged aluminum fins
- Aluminum tube construction
- Lanced fins for maximum fin surface exposure
- Fin collars grip tubing for maximum contact area
- Flared shoulder tubing connections
- Factory tested under high pressure
- Entire coil is accessible for cleaning

3 High Pressure Switch

- Protects the system from high pressure conditions
- Manual reset.

4 Low Pressure Switch

- Shuts off unit if suction pressure falls below setting
- Provides loss of charge and freeze-up protection
- Auto-reset

5 Hi-Capacity Liquid Line Drier

- Factory installed in the liquid line, the drier traps moisture or dirt that could contaminate the refrigerant system
- 100% molecular-sieve bead type drier

FEATURES

REFRIGERATION SYSTEM (continued)

Optional Accessories

Expansion Valve Kits

- Field installed on certain indoor units
- See TXV/Orifice Usage table
- Chatleff-style fitting

Freezestat

- Senses suction line temperature
- Cycles compressor off when suction line temperature falls below it's setpoint
- Opens at 29°F and closes at 58°F
- Installs on or near the discharge line of the evaporator or on the suction line

Refrigerant Line Kits

- Refrigerant lines are shipped refrigeration clean
- Lines are cleaned, dried, pressurized and sealed at factory
- Suction line fully insulated
- Lines are stubbed at both ends

NOTE - Not available for -060 models. Must be field fabricated.

COMPRESSOR

6 Scroll Compressor

- High efficiency with uniform suction flow
- Constant discharge flow, high volumetric efficiency and quiet operation
- Low gas pulses during compression reduces operational sound levels
- Compressor motor is internally protected from excessive current and temperature
- Muffler in discharge line reduces operating sound levels
- Compressor is installed in the unit on resilient rubber mounts for vibration free operation

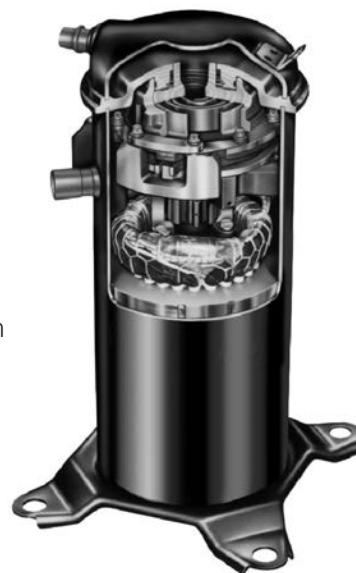

Scroll Compressor Operation

- Two involute spiral scrolls matched together generate a series of crescent-shaped gas pockets between them
- During compression, one scroll remains stationary while the other scroll orbits around it
- Gas is drawn into the outer pocket, the pocket is sealed as the scroll rotates
- As the spiral movement continues, gas pockets are pushed to the center of the scrolls. Volume between the pockets is simultaneously reduced
- When the pocket reaches the center, gas is now at high pressure and is forced out of a port located in the center of the fixed scrolls
- During compression, several pockets are compressed simultaneously resulting in a smooth continuous compression cycle
- Continuous flank contact, maintained by centrifugal force, minimizes gas leakage and maximizes efficiency
- Compressor is tolerant to the effects of slugging and contaminants. If this occurs, scrolls separate, allowing liquid or contaminants to be worked toward the center and discharged

Crankcase Heater

- Prevents migration of liquid refrigerant into compressor and ensures proper compressor lubrication

7 Compressor Sound Dampening System

- Polyethylene compressor cover contains a 2-inch thick batt of fiberglass insulation for improved sound dampening
- All open edges are sealed with a one-inch wide hook and loop fastening tape

FEATURES

CONTROLS

8 iComfort® Communicating Control

- Advanced control communicates information about various operating parameters in the air conditioner to the optional iComfort® Communicating Thermostat to constantly maintain the highest level of comfort, performance and efficiency available
- Connections for connecting a conventional heating/cooling thermostat are also provided on the control
- **Auto Configuration** - On start-up the control automatically sends a description of the unit to the optional iComfort® Communicating Thermostat to automatically configure the number of stages and features available



Seven-Segment Display

- Seven-segment display shows information about outdoor unit type and capacity and also displays alerts for common fault conditions (electrical and mechanical)
- Control also features:
 - Compressor anti-short cycle delay (5 minutes).
 - High and low pressure switch monitoring with provisions for lockout.
 - Five-Strike lockout protection protects compressor.
 - Discharge line and sensor monitoring.
 - Fan cycling operates outdoor fan for 5 minutes when outdoor ambient air temperature is between 15°F and 35°F and the compressor has been off for 25 to 30 minutes
 - Reduces the potential for ice buildup on the fan orifice ring. User selectable 5 minutes on or off (default setting)
 - Lennox Humiditrol® Whole Home Dehumidification System (EDA) compatible
 - EEPROM storage of all local configurations

Outdoor Air Temperature Sensor

- Used with iComfort® Communicating Thermostats
- Sensor allows thermostat to display outdoor temperature
- Sensor is auto-detected when connected to thermostat
- Also used for Humiditrol® applications

Optional Accessories

Compressor Hard Start Kit

- Single-phase units are equipped with a PSC compressor motor.
- A PSC compressor motor does not normally need a potential relay and start capacitor
- In cases of low voltage, kit may be required to increase the compressor starting torque

Indoor Blower Off Delay Relay

- Delays the indoor blower-off time during the cooling cycle

NOTE - Required if outdoor unit is used with a conventional heating-cooling thermostat and air handler (non-iComfort® control system). See furnace or air handler specifications to determine if relay is needed.

Low Ambient Kit

- Air conditioners can operate down to 45°F outdoor air temperature without additional controls
- Allows unit to operate properly down to 30°F

NOTE - Crankcase heater and frezestat should be installed on compressors equipped with a low ambient kit.

NOTE - A Compressor Low Ambient Cut-Off Switch should be added to terminate compressor operation below recommended operation conditions.

FEATURES

CONTROLS (continued)

Optional Accessories

iComfort® S30 Ultra-Smart Wi-Fi Thermostat (part of the iComfort® Residential Communicating Control System)

- Recognizes and connects to all iComfort® Communicating products to automatically configure and control the heating/cooling system (based on user-specified settings) for the highest level of comfort, performance and efficiency
- Recognizes model and serial number information for iComfort® Communicating products to simplify system setup
- Wi-Fi remote temperature monitoring and adjustment through a home wireless network for desktop PCs, laptops and apps for smartphones or tablets
- Smart home automation compatible with Apple HomeKit™, Amazon Alexa®, Google Assistant and IFTTT
- Service alerts and reminders sent via text message or e-mail
- Service Dashboard features online real-time monitoring of installed iComfort® thermostats
- Simple easy-to-use touchscreen allows complete system configuration
- Scheduled maintenance alerts, system warnings and troubleshooting are also displayed on thermostat screen
- Easy to read 7 inch high definition color display (measured diagonally)
- Conventional outdoor units (not iComfort® Communicating) can easily be added and controlled by the iComfort® S30 Thermostat
- Installer setup screens allow quick and simple system configuration without a manual, Installer can also run tests on complete system or individual components for easy maintenance and troubleshooting
- Serial communications bus (RSBus), with less wiring than a conventional heating/cooling system, allows system communication
- Uses 4-wire, standard thermostat wiring
- High Definition Color Display with Subbase, Smart Hub Controller, wallplate (for retrofit installations) furnished for easy installation



NOTE - See the iComfort® S30 Thermostat Product Specifications bulletin in the Controls section for more information

Thermostat

- Thermostat is not furnished with unit
- See Lennox Price Book for selection

CABINET

- 9 • Heavy-gauge steel construction
- Pre-painted cabinet finish
- Louvered heavy gauge steel panels surround unit on all four sides
- Control box is conveniently located with all controls factory wired
- Large removable panel provides service access
- Drainage holes are provided in base section for moisture removal
- High density polyethylene unit support feet raise the unit off of the mounting surface, away from damaging moisture

PermaGuard™ Unit Base

- Durable zinc-coated base section resists rust and corrosion

10 SmartHinge™ Louvered Coil Protection

- Steel louvered panels provides complete coil protection
- Panels are hinged to allow easy cleaning and servicing of coils
- Panels may be completely removed
- Interlocking tabs and slots assure tight fit on cabinet



11 Refrigerant Line Connections, Electrical Inlets and Service Valves

- Suction and liquid lines are located on corner of unit cabinet and are made with sweat connections
- Fully serviceable brass service valves prevent corrosion and provide access to refrigerant system. Suction valve can be fully shut off, while liquid valve may be front seated to manage refrigerant charge while servicing system
- Suction and liquid line service valves and gauge ports are located inside the cabinet
- Refrigerant line connections and field wiring inlets are located in one central area of the cabinet
- See dimension drawing

SPECIFICATIONS

General Data		Model No.	SL18XC1-024	SL18XC1-030	SL18XC1-036	SL18XC1-042	SL18XC1-048	SL18XC1-060
		Nominal Tonnage	2	2.5	3	3.5	4	5
Connections (sweat)	Liquid line (o.d.) - in.		3/8	3/8	3/8	3/8	3/8	3/8
	Suction line (o.d.) - in.		3/4	3/4	7/8	7/8	7/8	1-1/8
Refrigerant	¹ R-410A charge furnished		7 lbs. 0 oz.	8 lbs. 8 oz.	8 lbs. 8 oz.	10 lbs. 3 oz.	10 lbs. 13 oz.	12 lbs. 0 oz.
Outdoor Coil	Net face area - sq. ft.	Outer coil	27.21	23.32	23.32	23.32	27.21	27.21
		Inner coil	- - -	22.59	22.59	22.59	26.36	26.36
	Tube diameter - in.		5/16	5/16	5/16	5/16	5/16	5/16
	No. of rows		1	2	2	2	2	2
	Fins per inch		26	22	22	22	22	22
Outdoor Fan	Diameter - in.		26	26	26	26	26	26
	No. of blades		5	5	5	5	5	5
	Motor hp		1/3	1/3	1/3	1/3	1/3	1/3
	Cfm		3000	3050	3630	3630	4230	4230
	Rpm		450	500	600	600	675	675
	Watts		65	80	135	135	185	185
Shipping Data - lbs. 1 pkg.			241	258	260	280	296	298

ELECTRICAL DATA

Line voltage data - 60hz - 1 ph			208/230V	208/230V	208/230V	208/230V	208/230V	208/230V
² Maximum overcurrent protection (amps)			25	30	30	40	45	50
³ Minimum circuit ampacity			20	20	20	24.4	26.0	31.6
Compressor	Rated load amps		11.2	12.8	14.1	17.9	19.2	23.7
	Locked rotor amps		60.8	67.8	72.2	112.0	117	152.5
	Power factor		.97	.97	.99	.97	.97	.96
Outdoor Fan Motor	Full load amps		2.0	2.0	2.0	2.0	2.0	2.0

CONTROLS

iComfort® S30 Ultra-Smart Wi-Fi Thermostat	19V30	•	•	•	•	•	•
⁴ Discharge Air Temp. Sensor	88K38	•	•	•	•	•	•

OPTIONAL ACCESSORIES - ORDER SEPARATELY

Compressor Hard Start Kit	88M91	•	•	•	•	•	•
Freezestat	3/8 in. tubing	93G35	•	•	•	•	•
	5/8 in. tubing	50A93	•	•	•	•	•
Indoor Blower Off Delay Relay	58M81	•	•	•	•	•	•
⁵ Low Ambient Kit	68M04	•	•	•	•	•	•
Refrigerant Line Sets	L15-41-20, L15-41-40	•	•				
	L15-41-30, L15-41-50			•	•	•	
	L15-65-30, L15-65-40, L15-65-50						•
Field Fabricate							•

NOTE - Extremes of operating range are plus 10% and minus 5% of line voltage.

¹ Refrigerant charge sufficient for 15 ft. length of refrigerant lines.

² HACR type breaker or fuse.

³ Refer to National or Canadian Electrical Code manual to determine wire, fuse and disconnect size requirements.

⁴ Used with the iComfort® Communicating Thermostats for optional service diagnostics.

⁵ Freezestat is recommended with Low Ambient Kit.

INSTALLATION CLEARANCES

NOTES

One of the three sides must be 36 in. (914 mm).
 One of the two remaining sides may be 12 in. (305 mm).
 The remaining side may be 6 in. (152 mm).

Service Clearance – 30 in. (762 mm).

48 in. (1219 mm) clearance required on top of unit.

24 in. (610 mm) required between two units.

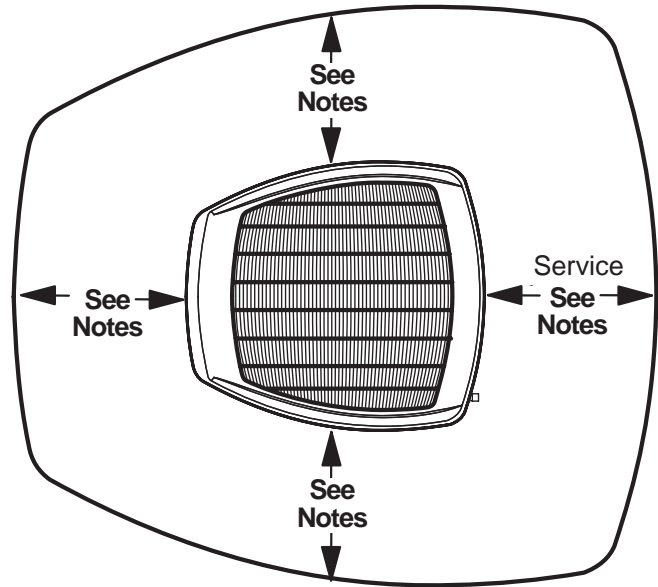

FIELD WIRING

- A - Two Wire Power (not furnished)
- B - Two Power (not furnished) See Electrical Data
- C - Four Wire Low Voltage (not furnished) 18 ga. minimum
- D - Four Wire Low Voltage RSBUS (not furnished) 18 ga. minimum
 - iComfort® Thermostat
 - Six Wire Low Voltage (not furnished) 18 ga. minimum
 - Conventional Thermostat

All wiring must conform to NEC or CEC and local electrical codes.

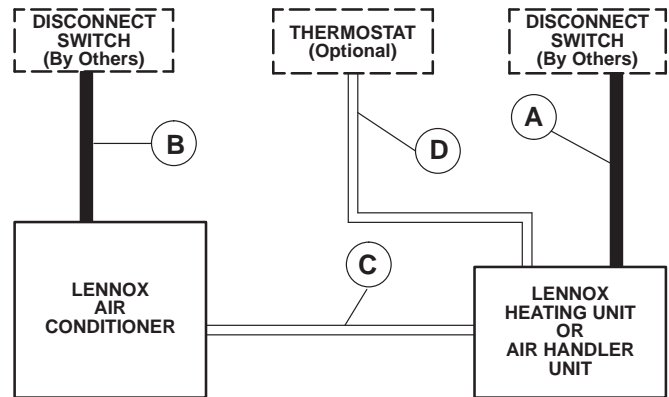

SOUND DATA

1 Unit Model	Octave Band Sound Power Levels dBA, re 10 ⁻¹² Watts Center Frequency - HZ							1 Sound Rating Number (dBA)	2 Estimated Sound Pressure Level at Distance From Unit (dBA at distance in ft.)				
	125	250	500	1000	2000	4000	8000		3	5	10	15	50
SL18XC1-024	68	67	66	60	52	47	45	65	58	53	47	44	33
SL18XC1-030	68	69	67	63	56	51	49	68	61	56	50	47	36
SL18XC1-036	72	72	71	65	59	53	48	71	64	59	53	50	39
SL18XC1-042	71	73	72	65	58	53	49	71	64	59	53	50	39
SL18XC1-048	72	74	75	68	62	56	51	74	67	62	56	53	42
SL18XC1-060	74	73	74	69	62	58	55	74	67	62	56	53	42

NOTE - The octave sound power data does not include tonal correction.

¹ Tested according to AHRI Standard 270-2008 test conditions.

² Estimated sound pressure level at distance based on AHRI Standard 275-2010 method for equipment located on the ground, roof, or on side of building wall with no adjacent reflective surface within 9.8 feet. Sound pressure levels will increase based on changes to assumptions. For other applications, refer to AHRI Standard 275.

DIMENSIONS - UNIT

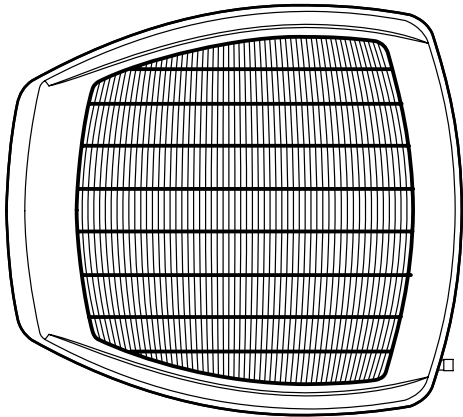

TOP VIEW

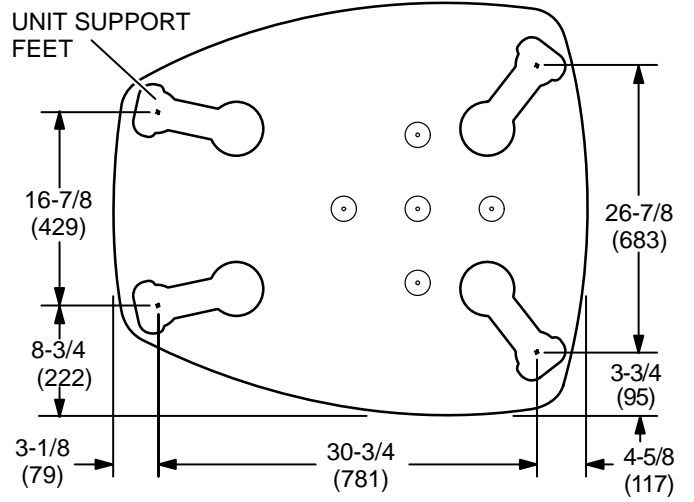

**TOP VIEW BASE SECTION
(Large Base)**

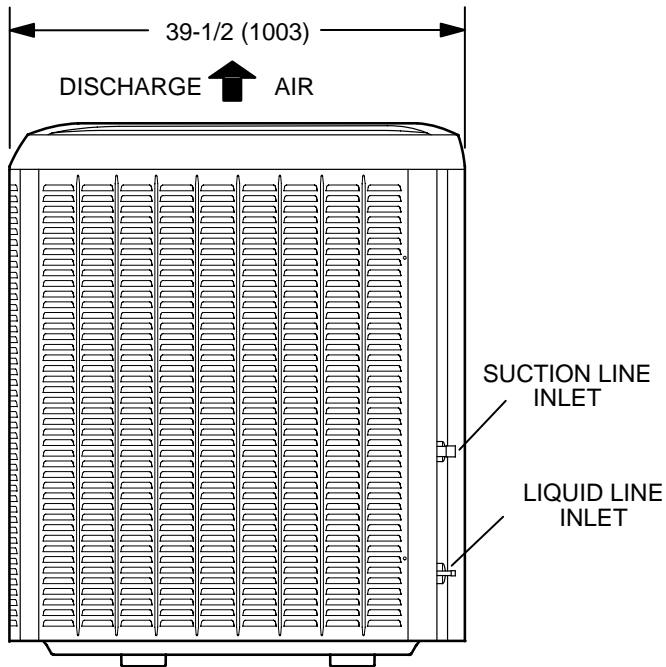

SIDE VIEW

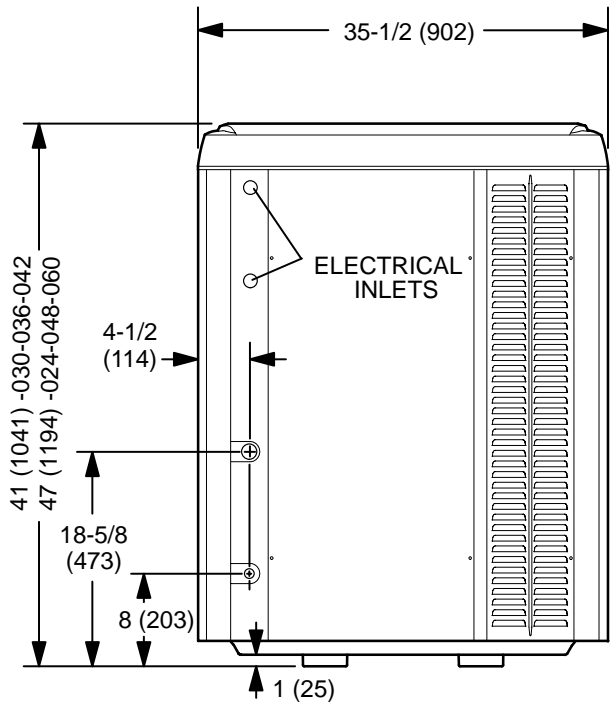

ACCESS VIEW

TXV USAGE

Use this table for C35, CH23, CH35 and CR33 Field Installed TXV Match-Ups

Outdoor Unit Model No.	Order No.
SL18XC1-024	12J18
SL18XC1-030	12J18
SL18XC1-036	12J19
SL18XC1-042	12J20
SL18XC1-048	12J20
SL18XC1-060	12J20

CX35 and CHX35 coils and all Lennox air handlers are shipped with a factory installed TXV. In most cases, no change out of the valve is needed.

If a change out is required it will be listed in the "TXV SUBSTITUTIONS" table by size. The correct TXV must be ordered separately and field installed.

C35 and CH35 coils - Replace the factory installed RFC orifice with the expansion valve listed.

CR33 and CH23 coils - Use the expansion valve listed.

AHRI STANDARD 210/240

Cooling or heating capacities are net values, including the effects of blower motor heat, and do not include supplementary heat. Power input is the total power input to the compressor(s) and fan(s), plus any controls and other items required as part of the system for normal operation.

Units which do not have an indoor air-circulating blower furnished as part of the model, i.e., split system with indoor coil only, is established by subtracting from the total cooling capacity 1250 Btu/h per 1,000 cfm, and by adding the same amount to the heating capacity. Total power input for both heating and cooling is increased by 365 W per 1,000 cfm of indoor air circulated.

TXV SUBSTITUTION

A general guide for replacing the factory installed TXV if the indoor unit (coil/air handler) is larger or smaller than the outdoor unit.

Outdoor Unit		Indoor Unit		TXV	TXV
Size	Tons	Size	Tons	Furnished	Replacement
024	2	42	3.5	12J20	12J18
024	2	48	4	12J20	12J18
024	2	49	4	12J20	12J18
024	2	50/60	5	12J20	12J18
024	2	51/61	5	12J20	12J18
024	2	60	5	12J20	12J18
030	2.5	42	3.5	12J20	12J18
030	2.5	43	3.5	12J20	12J18
030	2.5	48	4	12J20	12J18
030	2.5	49	4	12J20	12J18
036	3	24	2	12J18	12J19
036	3	30	2.5	12J18	12J19
042	3.5	24	2	12J18	12J20
042	3.5	30	2.5	12J18	12J20
042	3.5	30/36	3	12J19	12J20
042	3.5	36	3	12J19	12J20
048	4	30/36	2.5/3	12J19	12J20
048	4	36	3	12J19	12J20

TXV Ranges:

12J18 - 1.5 to 2.5 ton systems - Use on 2.5 ton (030) and lower systems.

12J19 - 3 ton systems - Use down to 2 ton (024) systems.

12J20 - 3.5 to 5 ton systems - Use down to 3 ton (036) systems.

REVISIONS

Sections	Description of Change
Optional Accessories	Updated.
TXV Substitutions	Updated.



Visit us at www.Lennox.com

For the latest technical information, www.LennoxPros.com

Contact us at 1-800-4-LENNOX

NOTE - Due to Lennox' ongoing commitment to quality, Specifications, Ratings and Dimensions subject to change without notice and without incurring liability. Improper installation, adjustment, alteration, service or maintenance can cause property damage or personal injury. Installation and service must be performed by a qualified installer and servicing agency.

©2020 Lennox Industries, Inc.