

4HP16L

PRODUCT SPECIFICATIONS

HIGH EFFICIENCY
SPLIT SYSTEM HEAT PUMP
UP TO 16 SEER & 9.5 HSPF

FORM NO. 4HP16L-100 (04/2020)



COMPRESSOR

- High-efficiency scroll compressor
- R410A refrigerant
- Grommet mounted compressor for quiet operation
- Heavy-duty compressor sound blanket for quiet operation
- Internally protected against high temperature motor overload conditions

CABINET

- Full metal louvered panel with 2 screws to remove for ease of coil cleaning and service
- Corner-mounted controls for easy service
- Baked polyester paint finished over galvanized steel for maximum durability
- External gauge ports for easy service
- Removable service panel for internal access

DESIGN

- Designed to perform in temperatures up to 125°F
- Designed to perform in temperatures down to 0°F

COILS

- Omniguard™ total corrosion protection technology designed coil
- Enhanced tube-and-fin coil design featuring MHT™ Technology
- Lanced fins for maximum heat transfer
- Factory tested for leakproof construction
- Raised coil prevents debris from impeding airflow

COMPONENTS

- Factory installed high and low pressure switches
- Thread-on pressure switches for simple, quick service
- Factory installed filter dryer
- Fan orifice for smoother airflow and sound level reduction
- Charged for 15 feet of line set
- Discharge muffler for quiet operation
- Quiet Shift™ capable to reduce noise during defrost

WARRANTY

- 10 year limited warranty on compressor
- 5 year limited warranty on all parts, extended warranty available*

**Warranty provides for a total of 10 years of limited warranty coverage (Standard 5-year limited parts warranty plus an additional 5-year limited extended parts warranty). Warranty must be registered online within 60 days of installation to qualify for 10-year coverage. Unregistered equipment defaults to 5-year coverage. See full warranty at www.alliedair.com for terms, conditions and exclusions.*

NOTE:

For the latest AHRI system matches, please visit www.alliedratings.com or www.AHRIdirectory.org



MODEL NUMBER GUIDE

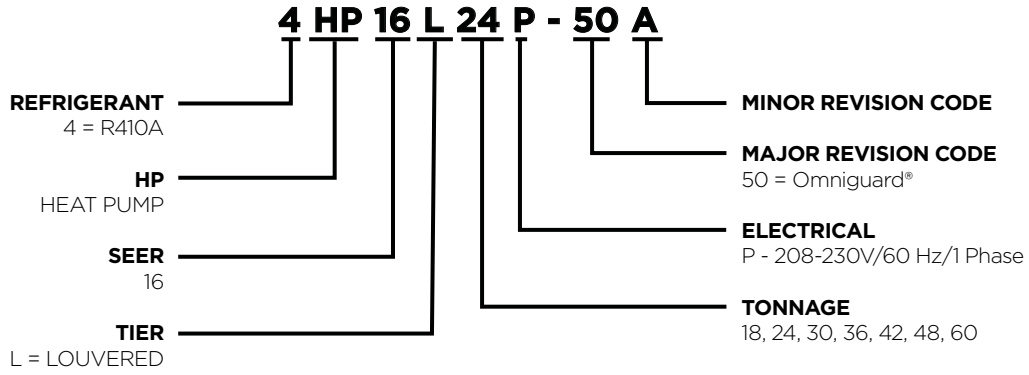

PHYSICAL AND ELECTRICAL DATA

Model	Voltage/Hz/ Phase	Voltage Range	Min. Circuit Amp.	Max. Over Current Device (amps)	Compressor		Outdoor Fan Motor		
					Rated Load (amps)	Locked Rotor (amps)	Full Load (amps)	Rated HP	Nom. RPM
4HP16L18P-50	208-230/60/1	197-253	10.6	20	7.7	48	1.0	1/6	825
4HP16L24P-50	208-230/60/1	197-253	13.6	20	10.1	52	1.0	1/6	825
4HP16L30P-50	208-230/60/1	197-253	16.4	25	12.3	63	1.0	1/6	825
4HP16L36P-50	208-230/60/1	197-253	20.9	35	14.7	75	2.6	1/3	820
4HP16L42P-50	208-230/60/1	197-253	25	40	17.9	112.3	2.6	1/3	820
4HP16L48P-50	208-230/60/1	197-253	25.8	40	18.5	124	2.6	1/3	820
4HP16L60P-50	208-230/60/1	197-253	30.4	50	22.2	127.9	2.6	1/3	820

UNIT DIMENSIONS (IN.)

Model	Dimensions (inch)			Shipping Weight (lbs.)
	A - Width	B - Depth	C - Height	
4HP16L18P-50	28.25	28.25	43	180
4HP16L24P-50	28.25	28.25	33	188
4HP16L30P-50	28.25	28.25	33	188
4HP16L36P-50	32.25	32.25	33	214
4HP16L42P-50	32.25	32.25	43	263
4HP16L48P-50	32.25	32.25	43	263
4HP16L60P-50	32.25	32.25	43	268

Note:
Dimensions listed are unit sizes w/o packaging
Weights listed are unit weights with packaging

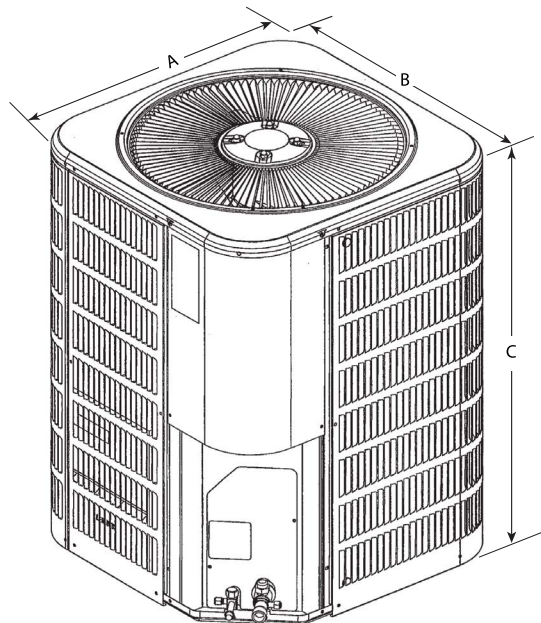

UNIT SOUND RATINGS

Model	Sound Power ¹	Estimated Sound Pressure (dBA) ²		
		Approximate Distance ³		
		3.3 Feet (1 Meter)	6.6 Feet (2 Meters)	9.8 Feet (3 Meters)
4HP16L18P-50	76	68	62	58
4HP16L24P-50	76	68	62	58
4HP16L30P-50	76	68	62	58
4HP16L36P-50	76	68	62	58
4HP16L42P-50	79	71	65	61
4HP16L48P-50	80	72	66	62
4HP16L60P-50	80	72	66	62

1 Rated in accordance with AHRI standard 270 (2015)
 2 Rated in accordance with AHRI standard 275 (2010)
 3 Based only on distance factor; other factors may change this value such as:
 - Unit location (reflective surfaces adjacent to the unit)
 - Barrier shielding sources
 - Sound path/elevation
 - Outside noise sources

REFRIGERATION DATA

Model	Refrig. Charge (Oz.)*	TXV	Refrigerant Line Size		Outdoor Unit Connection		Indoor Unit Connection	
			Suction	Liquid	Suction	Liquid	Suction	Liquid
4HP16L18P-50	114	H4TXV01	3/4	3/8	3/4	3/8	3/4	3/8
4HP16L24P-50	126	H4TXV01	3/4	3/8	3/4	3/8	3/4	3/8
4HP16L30P-50	132	H4TXV01	3/4	3/8	3/4	3/8	3/4	3/8
4HP16L36P-50	135	H4TXV02	7/8	3/8	7/8	3/8	7/8	3/8
4HP16L42P-50	180	H4TXV02	7/8	3/8	7/8	3/8	7/8	3/8
4HP16L48P-50	188	H4TXV02	7/8	3/8	7/8	3/8	7/8	3/8
4HP16L60P-50	182	H4TXV03	1-1/8	3/8	1-1/8	3/8	1-1/8	3/8

Note:
 * Factory charged for 15 feet of line set; adjust per installation instructions.
 ** Reducer fitting supplied with OD unit

COOLING PERFORMANCE WITH AIR HANDLERS AND FURNACES

Outdoor Model	Indoor Model	Cooling				Heating				
		SEER	EER	AHRI Rated Capacity ¹	Sensible Capacity	HSPF	47°		17°	
							Btuh	COP	Btuh	COP
4HP16L18P-50	BCE7E18M	16	13	18,000	15,300	9.5	17,200	3.9	10,800	2.59
4HP16L24P-50	BCE7E24M	16	13	24,000	18,400	9.5	22,000	3.79	14,000	2.58
4HP16L30P-50	BCE7E30M	16	13	29,800	23,000	9.5	27,400	3.81	17,600	2.64
4HP16L36P-50	BCE7E36M	16	13	35,400	27,200	9.5	34,000	3.79	22,400	2.75
4HP16L42P-50	BCE7E42M	16	13	41,000	30,500	9.5	38,000	3.75	24,500	2.66
4HP16L48P-50	BCE7E48M	16	13	46,000	34,500	9.5	43,000	3.68	28,500	2.73
4HP16L60P-50	BCE7E60M	15	12.5	56,000	39,000	9.5	53,000	3.6	35,000	2.66

Note:
 1 Certified in accordance with Unitary Air Conditioner Certification Program, which is based on AHRI Standard 210/240
 2 Required to achieve AHRI rating. If NA (not applicable) is in the piston column then TXV is required.
 3 Blower time delay relay is standard on all Allied Air Enterprises furnace and AH products.

NOTE:

For the latest AHRI system matches, please visit www.alliedratings.com or www.AHRIdirectory.org

ACCESSORIES

System Accessory	Where Used	Kit Number	Purpose
Liquid Line solenoid	All models	60M52	Prevents liquid migration to the compressor especially for high liquid riser applications
Low ambient HP units (cooling operation)	All models	54M89	Enables cooling demand down to 30 °F. Will require freeze stat, CC heater and TXV
Mild ambient (heating operation)	All models	11B97	Enables heating demand above 60 °F ambient
Cold weather	All models	1.921145	To allow unit to operate at very low ambient conditions (older models). Board integrated feature on new models
Fossil Fuel Kit (Heat Pump Only)	All models	1.841185 (AFOSL500)	Required for furnace with heat pump installations
Hard Start	24 & 36	10J42	Scroll compressors usually do not require hard start; maybe needed for utility brown-out or low voltage areas
	48 & 60	81J69	
Crankcase Heater	18, 24, 30	93M04	Prevents liquid migration to compressor in cold weather
	36, 42, 48, 60	Factory Installed	
Sound Cover	Factory Installed		Lowers compressor sound level
Loss of Charge Kit	Factory Installed		Protects the compressor if refrigerant charge is too low
Additional System Accessories (indoor section)			
TXV Kit	18, 24, 30	H4TXV01	TXVs provide superior refrigerant flow control, comfort and efficiency compared to pistons
	36, 42, 48	H4TXV02	
	60	H4TXV03	
Outdoor Thermostat - electric heat	All models	10Z23 (56A87)	Prevents electric heat operation above specific ambient conditions
Outdoor Thermostat - Mounting box	All models	31461	Mounting box for outdoor thermostat
Freeze stat	All models	93G35	Protects the compressor at low suction pressure conditions
Over flow switch	All models	11U75	Turn the system off, if condensate water overflows due to clogged drain pipes
Single point power supply	All models	21H39	Provide single power source in one junction box
Auxiliary blower relay	All models	85W66	Maybe required to select multiple indoor blower speeds

COOLING PERFORMANCE EXTENDED RATINGS

Note: Shaded area is AHRI Rating Conditions

Indoor Wet Bulb Temperature		Outdoor Air Temperature Entering Outdoor Coil																			
		85° F (29.4° C)				95° F (35° C)				105° F (40.6° C)				115° F (46.1° C)				125° F (51.7° C)			
		Total Air Volume	Total Cooling Capacity	Sensible To Total Ratio (S/T)		Comp. Motor Watts Input	Total Cooling Capacity	Sensible To Total Ratio (S/T)		Comp. Motor Watts Input	Total Cooling Capacity	Sensible To Total Ratio (S/T)		Comp. Motor Watts Input	Total Cooling Capacity	Sensible To Total Ratio (S/T)		Comp. Motor Watts Input	Total Cooling Capacity	Sensible To Total Ratio (S/T)	
				kBtu/h	kBtu/h			75°F / 23.9°C	80°F / 26.7°C			85°F / 29.4°C	75°F / 23.9°C			80°F / 26.7°C	85°F / 29.4°C			75°F / 23.9°C	80°F / 26.7°C
cfm	kBtu/h	75°F / 23.9°C	80°F / 26.7°C	85°F / 29.4°C	kBtu/h	75°F / 23.9°C	80°F / 26.7°C	85°F / 29.4°C	kBtu/h	75°F / 23.9°C	80°F / 26.7°C	85°F / 29.4°C	kBtu/h	75°F / 23.9°C	80°F / 26.7°C	85°F / 29.4°C	kBtu/h	75°F / 23.9°C	80°F / 26.7°C	85°F / 29.4°C	
4HP16L18P-50 - BCE7E18																					
570	18.5	1060	.94	1.00	1.00	1200	.99	1.00	1.00	15.9	.99	1.00	1.00	1540	1.00	1.00	1.00	1740	1.00	1.00	1.00
59°F (15°C)	675	19.5	1050	.99	1.00	1200	1.00	1.00	1.00	16.8	1.00	1.00	1.00	1540	1.00	1.00	1.00	1740	1.00	1.00	1.00
	735	20.0	1050	1.00	1.00	1200	1.00	1.00	1.00	17.2	1.00	1.00	1.00	1540	1.00	1.00	1.00	1740	1.00	1.00	1.00
	570	19.0	1050	.76	.90	1200	.80	.96	1.00	16.0	.80	.96	1.00	1540	.82	.99	1.00	1740	.86	1.00	1.00
63°F (17.2°C)	675	19.8	1050	.80	.96	1200	.84	1.00	1.00	16.8	.84	1.00	1.00	1540	.87	1.00	1.00	1740	.91	1.00	1.00
	735	20.2	1050	.82	.99	1200	.87	1.00	1.00	17.2	.87	1.00	1.00	1540	.90	1.00	1.00	1740	.94	1.00	1.00
	570	20.2	1050	.60	.74	1200	.61	.75	.89	18.2	.62	.77	.92	1540	.63	.80	.95	1740	.65	.82	.99
67°F (19.4°C)	675	21.0	1040	.62	.78	1200	.63	.79	.95	18.8	.64	.81	.98	1540	.67	.85	1.00	1740	.69	.89	1.00
	735	21.2	1040	.63	.80	1200	.64	.82	.98	19.1	.66	.85	1.00	1540	.68	.88	1.00	1740	.70	.92	1.00
	570	21.4	1040	.45	.58	1200	.45	.59	.73	19.3	.46	.60	.74	1540	.46	.62	.77	1740	.47	.64	.80
71°F (21.7°C)	675	22.0	1040	.46	.61	1200	.47	.62	.77	19.9	.47	.63	.79	1540	.48	.65	.82	1740	.49	.68	.85
	735	22.4	1040	.47	.62	1190	.48	.65	.79	20.2	.48	.65	.82	1550	.48	.67	.85	1740	.50	.69	.89
4HP16L24P-50 - BCE7E24																					
660	22.2	1290	.92	1.00	1.00	1460	.95	1.00	1.00	20.2	.98	1.00	1.00	1870	1.00	1.00	1.00	2140	1.00	1.00	1.00
59°F (15°C)	790	23.6	1280	.98	1.00	1450	1.00	1.00	1.00	21.6	1.00	1.00	1.00	1860	1.00	1.00	1.00	2150	1.00	1.00	1.00
	895	24.6	1270	1.00	1.00	1440	1.00	1.00	1.00	22.2	1.00	1.00	1.00	1850	1.00	1.00	1.00	2120	1.00	1.00	1.00
	660	23.2	1290	.75	.89	1450	.76	.91	1.00	20.6	.79	.94	1.00	1860	.81	.98	1.00	2140	.85	1.00	1.00
63°F (17.2°C)	790	24.0	1280	.79	.95	1450	.81	.97	1.00	21.6	.83	1.00	1.00	1850	.87	1.00	1.00	2130	.91	1.00	1.00
	895	24.8	1270	.82	.98	1440	.84	1.00	1.00	22.4	.87	1.00	1.00	1840	.91	1.00	1.00	2120	.96	1.00	1.00
	660	24.6	1270	.59	.72	1440	.60	.74	.87	22.2	.61	.76	.90	1840	.63	.79	.94	2120	.65	.82	.98
67°F (19.4°C)	790	25.6	1260	.61	.76	1430	.62	.78	.94	23.0	.64	.81	.97	1830	.66	.84	1.00	2120	.68	.88	1.00
	895	26.4	1250	.63	.80	1420	.65	.82	.98	23.6	.66	.85	1.00	1830	.68	.88	1.00	2110	.71	.93	1.00
	660	26.2	1250	.45	.57	1420	.45	.58	.71	23.4	.45	.60	.73	1830	.46	.61	.76	2110	.47	.63	.79
71°F (21.7°C)	790	27.2	1240	.46	.60	1410	.46	.61	.76	24.4	.47	.62	.78	1810	.47	.64	.81	2090	.48	.67	.85
	895	27.8	1230	.46	.62	1400	.47	.63	.79	25.0	.48	.65	.82	1810	.49	.67	.85	2090	.50	.70	.90

COOLING PERFORMANCE EXTENDED RATINGS

Note: Shaded area is AHRI Rating Conditions

Indoor Wet Bulb Temperature	Outdoor Air Temperature Entering Outdoor Coil																									
	85° F (29.4° C)				95° F (35° C)				105° F (40.6° C)				115° F (46.1° C)				125° F (51.7° C)									
	Total Cooling Capacity		Sensible To Total Ratio (S/T)		Comp. Motor Watts		Sensible To Total Ratio (S/T)		Comp. Motor Watts		Total Cooling Capacity		Sensible To Total Ratio (S/T)		Comp. Motor Watts		Total Cooling Capacity		Sensible To Total Ratio (S/T)		Comp. Motor Watts					
	kBtuh	cfm	75°F 23.9°C	80°F 26.7°C	85°F 29.4°C	Input	75°F 23.9°C	80°F 26.7°C	85°F 29.4°C	Input	kBtuh	75°F 23.9°C	80°F 26.7°C	85°F 29.4°C	Input	kBtuh	75°F 23.9°C	80°F 26.7°C	85°F 29.4°C	Input	kBtuh	75°F 23.9°C	80°F 26.7°C	85°F 29.4°C	Input	
4HP16L30P-50-BCE7E30																										
59°F (15°C)	845	28.0	1600	.93	1.00	.96	1.00	1.00	1.00	25.2	2070	.99	1.00	1.00	23.6	2340	1.00	1.00	1.00	1.00	22.0	2670	1.00	1.00	1.00	1.00
	1035	29.8	1610	.99	1.00	1.00	1.00	1.00	1.00	26.8	2070	1.00	1.00	1.00	25.2	2350	1.00	1.00	1.00	1.00	23.4	2670	1.00	1.00	1.00	1.00
	1165	30.8	1610	1.00	1.00	1.00	1.00	1.00	1.00	27.8	2080	1.00	1.00	1.00	26.0	2350	1.00	1.00	1.00	1.00	24.0	2670	1.00	1.00	1.00	1.00
63°F (17.2°C)	845	29.0	1610	.75	.89	.77	.92	1.00	1.00	25.8	2070	.79	.95	1.00	23.8	2340	.82	.99	1.00	1.00	22.0	2660	.86	1.00	1.00	1.00
	1035	30.2	1610	.80	.96	.82	.98	1.00	1.00	26.8	2070	.85	1.00	1.00	25.2	2350	.88	1.00	1.00	1.00	23.4	2670	.93	1.00	1.00	1.00
	1165	31.0	1610	.83	.99	.85	1.00	1.00	1.00	27.8	2080	.89	1.00	1.00	26.0	2350	.93	1.00	1.00	1.00	24.0	2670	.97	1.00	1.00	1.00
67°F (19.4°C)	845	30.8	1610	.59	.73	.60	.74	.88	.88	27.4	2070	.61	.76	.91	25.4	2350	.63	.79	.95	.95	23.2	2670	.65	.83	.99	1.00
	1035	32.2	1610	.62	.77	.63	.80	.95	.95	28.4	2080	.65	.82	.98	26.4	2350	.67	.86	1.00	1.00	24.0	2670	.70	.90	1.00	1.00
	1165	32.8	1620	.64	.81	.65	.83	.99	.99	29.0	2080	.67	.86	1.00	26.8	2360	.69	.90	1.00	1.00	24.4	2680	.73	.95	1.00	1.00
71°F (21.7°C)	845	32.6	1620	.45	.57	.45	.59	.72	.72	29.0	2080	.45	.60	.74	27.0	2360	.46	.62	.77	.77	24.8	2680	.47	.64	.80	.88
	1035	34.0	1620	.46	.61	.46	.62	.77	.77	30.2	2080	.47	.64	.80	28.0	2360	.48	.66	.83	.83	25.6	2680	.49	.68	.83	.91
	1165	34.8	1620	.47	.63	.47	.64	.81	.81	30.8	2090	.48	.66	.84	28.6	2360	.49	.68	.87	.87	26.2	2680	.50	.72	.87	.92
4HP16L36P-50-BCE7E36																										
59°F (15°C)	1035	33.4	1900	.92	1.00	.95	1.00	1.00	1.00	30.4	2450	.97	1.00	1.00	28.8	2780	.99	1.00	1.00	1.00	27.0	3180	1.00	1.00	1.00	1.00
	1200	35.0	1910	.97	1.00	.99	1.00	1.00	1.00	31.8	2450	1.00	1.00	1.00	30.2	2790	1.00	1.00	1.00	1.00	28.2	3190	1.00	1.00	1.00	1.00
	1365	36.4	1910	1.00	1.00	1.00	1.00	1.00	1.00	33.2	2460	1.00	1.00	1.00	31.4	2800	1.00	1.00	1.00	1.00	29.2	3190	1.00	1.00	1.00	1.00
63°F (17.2°C)	1035	34.8	1900	.75	.89	.76	.91	1.00	1.00	31.2	2450	.78	.94	1.00	29.2	2780	.80	.97	1.00	1.00	27.2	3190	.83	1.00	1.00	1.00
	1200	35.8	1910	.78	.93	.80	.96	1.00	1.00	32.2	2460	.82	.98	1.00	30.2	2790	.85	1.00	1.00	1.00	28.4	3190	.88	1.00	1.00	1.00
	1365	36.8	1920	.81	.97	.83	.99	1.00	1.00	33.2	2460	.86	1.00	1.00	31.2	2790	.89	1.00	1.00	1.00	29.2	3190	.93	1.00	1.00	1.00
67°F (19.4°C)	1035	37.0	1920	.59	.72	.60	.74	.87	.87	33.2	2460	.61	.75	.90	31.2	2800	.62	.78	.93	.93	28.8	3190	.64	.81	.97	.97
	1200	38.0	1930	.61	.75	.62	.77	.92	.92	34.2	2470	.63	.79	.95	32.0	2800	.65	.82	.98	.98	29.6	3200	.67	.85	1.00	1.00
	1365	39.0	1930	.63	.78	.64	.81	.97	.97	35.0	2480	.65	.83	.99	32.8	2810	.67	.86	1.00	1.00	30.2	3200	.70	.90	1.00	1.00
71°F (21.7°C)	1035	39.0	1930	.45	.57	.45	.58	.71	.71	35.2	2480	.45	.59	.73	33.2	2810	.46	.61	.75	.75	30.6	3200	.47	.63	.78	.78
	1200	40.5	1950	.46	.59	.46	.60	.74	.74	36.4	2490	.47	.62	.77	34.0	2820	.47	.63	.79	.79	31.6	3210	.48	.66	.83	.83
	1365	41.5	1950	.46	.61	.47	.63	.78	.78	37.2	2500	.47	.64	.81	34.8	2830	.48	.66	.83	.83	32.2	3220	.49	.68	.87	.87

COOLING PERFORMANCE EXTENDED RATINGS

Note: Shaded area is AHRI Rating Conditions

Indoor Wet Bulb Temperature	Outdoor Air Temperature Entering Outdoor Coil																									
	85° F (29.4° C)				95° F (35° C)				105° F (40.6° C)				115° F (46.1° C)				125° F (51.7° C)									
	Total Cooling Capacity		Sensible To Total Ratio (S/T)		Comp. Motor Watts Input		Sensible To Total Ratio (S/T)		Comp. Motor Watts Input		Total Cooling Capacity		Sensible To Total Ratio (S/T)		Comp. Motor Watts Input		Total Cooling Capacity		Sensible To Total Ratio (S/T)		Comp. Motor Watts Input					
	kBTuh	cfm	75°F 23.9°C	80°F 26.7°C	85°F 29.4°C	kBTuh	Watts	75°F 23.9°C	80°F 26.7°C	85°F 29.4°C	kBTuh	Watts	75°F 23.9°C	80°F 26.7°C	85°F 29.4°C	kBTuh	Watts	75°F 23.9°C	80°F 26.7°C	85°F 29.4°C	kBTuh	Watts				
4HP16L42P-50-BCE7E42																										
59°F (15°C)	1225	39.5	2200	.94	1.00	1.00	.96	1.00	.98	1.00	1.00	36.0	2810	.98	1.00	1.00	34.4	3170	1.00	1.00	1.00	32.4	3590	1.00	1.00	1.00
	1400	41.0	2200	.98	1.00	1.00	1.00	1.00	1.00	1.00	37.4	2810	1.00	1.00	1.00	1.00	35.6	3180	1.00	1.00	1.00	33.4	3600	1.00	1.00	1.00
	1570	42.0	2200	1.00	1.00	1.00	1.00	1.00	1.00	1.00	38.5	2810	1.00	1.00	1.00	1.00	36.6	3180	1.00	1.00	1.00	34.4	3600	1.00	1.00	1.00
63°F (17.2°C)	1225	40.5	2200	.76	.90	1.00	.77	.93	1.00	.95	1.00	36.6	2810	.79	.95	1.00	34.6	3180	.82	.98	1.00	32.4	3590	.84	1.00	1.00
	1400	41.5	2200	.79	.95	1.00	.81	.97	1.00	.83	1.00	37.8	2810	.83	.99	1.00	35.6	3180	.85	1.00	1.00	33.4	3590	.88	1.00	1.00
	1570	42.5	2200	.82	.98	1.00	.84	1.00	1.00	.86	1.00	38.5	2810	.86	1.00	1.00	36.6	3180	.89	1.00	1.00	34.4	3600	.93	1.00	1.00
67°F (19.4°C)	1225	43.0	2200	.60	.73	.87	.61	.75	.89	.62	.77	39.0	2810	.62	.77	.92	36.6	3180	.63	.79	.95	34.0	3600	.65	.82	.98
	1400	44.0	2200	.62	.77	.91	.63	.78	.94	.64	.81	42.0	2490	.64	.81	.97	37.2	3180	.65	.83	.99	34.8	3600	.67	.86	1.00
	1570	45.0	2200	.64	.80	.96	.65	.82	.97	.66	.84	40.5	2820	.66	.84	1.00	38.0	3180	.68	.87	1.00	35.2	3600	.70	.91	1.00
71°F (21.7°C)	1225	45.0	2200	.45	.58	.71	.45	.59	.73	.46	.60	41.0	2820	.46	.60	.75	38.5	3180	.47	.62	.77	36.0	3600	.47	.64	.80
	1400	46.5	2200	.46	.60	.74	.46	.62	.76	.47	.63	42.0	2820	.47	.63	.78	39.5	3190	.48	.64	.81	36.8	3600	.48	.66	.84
	1570	47.0	2200	.47	.62	.78	.47	.64	.79	.48	.65	42.5	2820	.48	.65	.82	40.0	3190	.49	.67	.85	37.4	3600	.49	.69	.88
4HP16L48P-50-BCE7E48																										
59°F (15°C)	1370	44.5	2560	.92	1.00	1.00	.94	1.00	1.00	.97	1.00	41.0	3280	.97	1.00	1.00	38.5	3720	.99	1.00	1.00	36.4	4220	1.00	1.00	1.00
	1470	45.5	2560	.94	1.00	1.00	.96	1.00	1.00	.99	1.00	41.5	3280	.99	1.00	1.00	39.5	3730	1.00	1.00	1.00	37.0	4230	1.00	1.00	1.00
	1715	47.5	2570	.99	1.00	1.00	1.00	1.00	1.00	1.00	1.00	43.5	3290	1.00	1.00	1.00	41.0	3730	1.00	1.00	1.00	38.5	4230	1.00	1.00	1.00
63°F (17.2°C)	1370	46.0	2560	.75	.89	1.00	.76	.91	1.00	.78	.93	42.0	3280	.78	.93	1.00	39.5	3730	.81	.96	1.00	36.4	4220	.83	.99	1.00
	1470	47.0	2570	.76	.91	1.00	.78	.93	1.00	.80	.96	42.5	3280	.80	.96	1.00	40.0	3730	.82	.98	1.00	37.0	4230	.85	1.00	1.00
	1715	48.0	2570	.80	.96	1.00	.82	.98	1.00	.84	1.00	43.5	3290	.84	1.00	1.00	41.0	3730	.87	1.00	1.00	38.5	4240	.90	1.00	1.00
67°F (19.4°C)	1370	48.5	2570	.59	.73	.85	.60	.74	.87	.61	.76	44.0	3290	.61	.76	.90	41.5	3730	.62	.78	.93	38.5	4240	.64	.81	.97
	1470	49.5	2570	.60	.74	.88	.61	.76	.90	.62	.78	44.5	3290	.62	.78	.92	42.0	3740	.64	.80	.96	39.0	4240	.65	.83	.99
	1715	50.5	2570	.63	.78	.93	.64	.80	.95	.65	.82	46.0	3300	.65	.82	.98	43.0	3740	.66	.85	1.00	40.0	4240	.69	.88	1.00
71°F (21.7°C)	1370	51.0	2570	.45	.58	.70	.45	.59	.72	.46	.60	46.5	3300	.46	.60	.73	43.5	3740	.46	.61	.76	40.5	4250	.47	.63	.79
	1470	52.0	2570	.45	.59	.72	.46	.60	.73	.46	.61	47.0	3300	.46	.61	.75	44.0	3740	.47	.62	.78	41.0	4250	.48	.64	.81
	1715	53.5	2580	.47	.61	.76	.47	.62	.77	.47	.64	48.5	3310	.47	.64	.80	45.5	3750	.48	.65	.82	42.0	4250	.49	.68	.86

COOLING PERFORMANCE EXTENDED RATINGS

Note: Shaded area is AHRI Rating Conditions

Indoor Wet Bulb Temperature		Outdoor Air Temperature Entering Outdoor Coil																																			
		85° F (29.4° C)						95° F (35° C)						105° F (40.6° C)						115° F (46.1° C)						125° F (51.7° C)											
		Sensible To Total Ratio (S/T)			Comp. Motor Watts Input			Total Cooling Capacity			Sensible To Total Ratio (S/T)			Comp. Motor Watts Input			Total Cooling Capacity			Sensible To Total Ratio (S/T)			Comp. Motor Watts Input			Total Cooling Capacity			Sensible To Total Ratio (S/T)			Comp. Motor Watts Input			Total Cooling Capacity		
		Indoor Dry Bulb		Indoor Dry Bulb	Indoor Dry Bulb		Indoor Dry Bulb	Indoor Dry Bulb		Indoor Dry Bulb	Indoor Dry Bulb		Indoor Dry Bulb	Indoor Dry Bulb		Indoor Dry Bulb	Indoor Dry Bulb		Indoor Dry Bulb	Indoor Dry Bulb		Indoor Dry Bulb	Indoor Dry Bulb		Indoor Dry Bulb	Indoor Dry Bulb		Indoor Dry Bulb	Indoor Dry Bulb		Indoor Dry Bulb	Indoor Dry Bulb		Indoor Dry Bulb			
Total Air Volume	cfm	75°F	80°F		85°F	75°F		80°F	85°F		75°F	80°F		85°F	75°F		80°F	85°F		75°F	80°F		85°F	75°F		80°F	85°F		75°F	80°F		85°F	75°F		80°F	85°F	75°F
		23.9°C	26.7°C	29.4°C	23.9°C	26.7°C	29.4°C	23.9°C	26.7°C	29.4°C	23.9°C	26.7°C	29.4°C	23.9°C	26.7°C	29.4°C	23.9°C	26.7°C	29.4°C	23.9°C	26.7°C	29.4°C	23.9°C	26.7°C	29.4°C	23.9°C	26.7°C	29.4°C	23.9°C	26.7°C	29.4°C	23.9°C	26.7°C	29.4°C	23.9°C	26.7°C	29.4°C
		4HP16L60P-50-BCE7E60																																			
1440	52.5	3420	.86	.98	1.00	3840	.88	1.00	1.00	48.5	4310	.90	1.00	1.00	46.5	4860	.92	1.00	1.00	44.0	5520	.96	1.00	1.00	5520	.96	1.00	1.00	44.0	5520	.96	1.00	1.00				
59°F (15°C)	1600	54.5	3420	.89	1.00	3840	.90	1.00	1.00	50.5	4320	.93	1.00	1.00	48.0	4870	.95	1.00	1.00	45.0	5530	.99	1.00	1.00	5530	.99	1.00	1.00	45.0	5530	.99	1.00	1.00				
	1750	56.0	3420	.91	1.00	3840	.93	1.00	1.00	52.0	4320	.95	1.00	1.00	49.0	4870	.98	1.00	1.00	46.0	5530	1.00	1.00	1.00	5530	1.00	1.00	1.00	46.0	5530	1.00	1.00	1.00				
	1440	55.5	3420	.71	.83	3840	.72	.85	.97	51.0	4320	.74	.87	.99	48.0	4870	.75	.89	1.00	45.0	5530	.77	.93	1.00	5530	.77	.93	1.00	45.0	5530	.77	.93	1.00				
63°F (17.2°C)	1600	57.0	3420	.73	.85	3840	.74	.87	.99	52.0	4320	.76	.89	1.00	49.0	4870	.78	.92	1.00	46.0	5530	.80	.96	1.00	5530	.80	.96	1.00	46.0	5530	.80	.96	1.00				
	1750	58.0	3420	.74	.88	3850	.76	.90	1.00	53.0	4320	.77	.92	1.00	50.0	4880	.80	.95	1.00	46.5	5530	.82	.98	1.00	5530	.82	.98	1.00	46.5	5530	.82	.98	1.00				
67°F (19.4°C)	1440	58.5	3420	.57	.69	3840	.58	.70	.81	53.5	4320	.59	.71	.83	50.5	4880	.60	.73	.86	47.5	5540	.61	.75	.89	5540	.61	.75	.89	47.5	5540	.61	.75	.89				
	1600	60.0	3420	.59	.71	3850	.59	.72	.84	54.5	4320	.60	.73	.86	51.5	4880	.61	.75	.89	48.0	5540	.63	.78	.93	5540	.63	.78	.93	48.0	5540	.63	.78	.93				
	1750	61.0	3430	.59	.72	3850	.60	.74	.87	55.5	4330	.61	.75	.89	52.5	4880	.62	.77	.92	49.0	5540	.64	.80	.96	5540	.64	.80	.96	49.0	5540	.64	.80	.96				
71°F (21.7°C)	1440	61.5	3430	.44	.55	3850	.45	.56	.68	56.0	4320	.45	.57	.69	53.0	4890	.45	.58	.71	49.5	5540	.46	.60	.73	5540	.46	.60	.73	49.5	5540	.46	.60	.73				
	1600	62.5	3430	.45	.57	3850	.45	.58	.69	57.0	4330	.45	.59	.71	54.0	4890	.46	.60	.73	50.5	5540	.46	.61	.75	5540	.46	.61	.75	50.5	5540	.46	.61	.75				
	1750	64.0	3420	.45	.58	3850	.45	.59	.71	58.5	4330	.46	.60	.73	55.0	4890	.46	.61	.75	51.5	5550	.47	.63	.78	5550	.47	.63	.78	51.5	5550	.47	.63	.78				

HEATING PERFORMANCE EXTENDED RATINGS

4HP16L18P-50 - BCE7E18

Indoor Coil Air Volume 70°F db (28°C db)		Air Temperature Entering Outdoor Coil																		
		65°F (18°C)				45°F (7°C)				25°F (-4°C)				5°F (-15°C)			-15°F (-28°C)			
		Total Heating Capacity		Comp. Motor Watts Input		Total Heating Capacity		Comp. Motor Watts Input		Total Heating Capacity		Comp. Motor Watts Input		Total Heating Capacity		Comp. Motor Watts Input	Total Heating Capacity		Comp. Motor Watts Input	
CFM	L/s	kBtuh	kW	kBtuh	kW	kBtuh	kW	kBtuh	kW	kBtuh	kW	kBtuh	kW	kBtuh	kW	kBtuh	kW	kBtuh	kW	
535	250	20.8	6.1	1170	16.3	4.8	1125	11.7	3.4	1080	7.9	2.3	990	3.8	1.1	735				
700	330	21.3	6.2	1100	16.8	4.9	1055	12.2	3.6	1005	8.4	2.5	915	4.3	1.3	660				
825	390	21.8	6.4	1060	17.3	5.1	1015	12.7	3.7	970	8.9	2.6	875	4.8	1.4	625				

Outdoor Temp.	°F	65	60	55	50	47	45	40	35	30	25	20	17	15	10	5	0	-5	-10	-15	-20
	°C	18	16	13	10	8	7	4	2	-1	-4	-7	-8	-9	-12	-15	-18	-21	-23	-26	-29
Compressor Motor kW Input		1.1	1.09	1.08	1.07	1.06	1.06	1.04	1.03	1.02	1.01	1	1	0.99	0.98	0.92	0.85	0.79	0.73	0.66	0.6
Total Output	kBtuh	21.3	20.2	19.1	18	17.4	16.8	15.3	13.8	13	12.2	11.4	10.9	10.5	9.4	8.4	7.4	6.3	5.3	4.3	3.3
	kW	6.2	5.9	5.6	5.3	5.1	4.9	4.5	4.0	3.8	3.6	3.3	3.2	3.1	2.8	2.5	2.2	1.8	1.6	1.3	1.0

	Inputs											
	Cap	6.2		5.9		5.6		5.3		5.1		
	Low		Med				High					
CFM	535		700				825					
47°F	16889.04		1132.503		17381.875		1058.653		17884.67		1021.314	
35°F	---		---		13787.179		1023.683		---		---	
17°F	---		---		10923.586		993.605		---		---	

4HP16L24P-50 - BCE7E24

Indoor Coil Air Volume 70°F db (28°C db)		Air Temperature Entering Outdoor Coil																		
		65°F (18°C)				45°F (7°C)				25°F (-4°C)				5°F (-15°C)			-15°F (-28°C)			
		Total Heating Capacity		Comp. Motor Watts Input		Total Heating Capacity		Comp. Motor Watts Input		Total Heating Capacity		Comp. Motor Watts Input		Total Heating Capacity		Comp. Motor Watts Input	Total Heating Capacity		Comp. Motor Watts Input	
CFM	L/s	kBtuh	kW	kBtuh	kW	kBtuh	kW	kBtuh	kW	kBtuh	kW	kBtuh	kW	kBtuh	kW	kBtuh	kW	kBtuh	kW	
660	310	26.4	7.7	1545	20.7	6.1	1460	14.8	4.3	1370	10.4	3.0	1255	5.1	1.5	930				
790	375	26.9	7.9	1470	21.2	6.2	1390	15.3	4.5	1300	10.9	3.2	1185	5.6	1.6	860				
895	420	27.2	8.0	1430	21.5	6.3	1345	15.6	4.6	1255	11.2	3.3	1145	5.9	1.7	815				

Outdoor Temp.	°F	65	60	55	50	47	45	40	35	30	25	20	17	15	10	5	0	-5	-10	-15	-20
	°C	18	16	13	10	8	7	4	2	-1	-4	-7	-8	-9	-12	-15	-18	-21	-23	-26	-29
Compressor Motor kW Input		1.47	1.46	1.44	1.42	1.41	1.39	1.35	1.31	1.31	1.3	1.3	1.3	1.29	1.27	1.19	1.11	1.02	0.94	0.86	0.78
Total Output	kBtuh	26.9	25.6	24.3	22.9	22.1	21.2	19	16.8	16	15.3	14.6	14.1	13.6	12.3	10.9	9.6	8.3	6.9	5.6	4.2
	kW	7.9	7.5	7.1	6.7	6.5	6.2	5.6	4.9	4.7	4.5	4.3	4.1	4.0	3.6	3.2	2.8	2.4	2.0	1.6	1.2

	Inputs											
	Cap	Watts		Cap	Watts		Cap	Watts				
	Low		Med				High					
CFM	660		790				895					
47°F	21620.677		1476.954		22128.434		1405.425		22433.405		1362.889	
35°F	---		---		16763.115		1307.426		---		---	
17°F	---		---		14135.974		1293.85		---		---	

HEATING PERFORMANCE EXTENDED RATINGS

4HP16L30P-50 - BCE7E30

Indoor Coil Air Volume 70°F db (28°C db)		Air Temperature Entering Outdoor Coil																		
		65°F (18°C)				45°F (7°C)				25°F (-4°C)				5°F (-15°C)			-15°F (-28°C)			
		Total Heating Capacity		Comp. Motor Watts Input		Total Heating Capacity		Comp. Motor Watts Input		Total Heating Capacity		Comp. Motor Watts Input		Total Heating Capacity		Comp. Motor Watts Input	Total Heating Capacity		Comp. Motor Watts Input	
CFM	L/s	kBtuh	kW	kBtuh	kW	kBtuh	kW	kBtuh	kW	kBtuh	kW	kBtuh	kW	kBtuh	kW	kBtuh	kW	kBtuh	kW	
845	400	32.8	9.6	1965	25.8	7.6	1850	18.6	5.5	1735	13.1	3.8	1570	6.4	1.9	1170	6.4	1.9	1170	
1035	490	33.4	9.8	1855	26.4	7.7	1745	19.2	5.6	1625	13.7	4.0	1460	7.0	2.1	1060	7.0	2.1	1060	
1165	550	33.6	9.8	1805	26.6	7.8	1690	19.4	5.7	1575	13.9	4.1	1410	7.2	2.1	1010	7.2	2.1	1010	

Outdoor Temp.	°F	65	60	55	50	47	45	40	35	30	25	20	17	15	10	5	0	-5	-10	-15	-20
	°C	18	16	13	10	8	7	4	2	-1	-4	-7	-8	-9	-12	-15	-18	-21	-23	-26	-29
Compressor Motor kW Input		1.86	1.83	1.81	1.78	1.76	1.75	1.7	1.66	1.64	1.63	1.61	1.6	1.59	1.56	1.46	1.36	1.26	1.16	1.06	0.96
Total Output	kBtuh	33.4	31.8	30.1	28.5	27.5	26.4	23.8	21.1	20.1	19.2	18.2	17.7	17	15.4	13.7	12	10.3	8.7	7	5.3
	kW	9.8	9.3	8.8	8.4	8.1	7.7	7.0	6.2	5.9	5.6	5.3	5.2	5.0	4.5	4.0	3.5	3.0	2.5	2.1	1.6

	Inputs					
	Cap	6.2	5.9	5.6	5.3	5.1
	Low	Med	High			
CFM	845	1035	1165			
47°F	26910.42	1868.432	27508.309	1760.221	27716.395	1709.049
35°F	---	---	21084.648	1658.685	---	---
17°F	---	---	17678.117	1599.322	---	---

4HP16L36P-50 - BCE7E36

Indoor Coil Air Volume 70°F db (28°C db)		Air Temperature Entering Outdoor Coil																		
		65°F (18°C)				45°F (7°C)				25°F (-4°C)				5°F (-15°C)			-15°F (-28°C)			
		Total Heating Capacity		Comp. Motor Watts Input		Total Heating Capacity		Comp. Motor Watts Input		Total Heating Capacity		Comp. Motor Watts Input		Total Heating Capacity		Comp. Motor Watts Input	Total Heating Capacity		Comp. Motor Watts Input	
CFM	L/s	kBtuh	kW	kBtuh	kW	kBtuh	kW	kBtuh	kW	kBtuh	kW	kBtuh	kW	kBtuh	kW	kBtuh	kW	kBtuh	kW	
1035	490	40.9	12.0	2465	32.6	9.6	2280	24.0	7.0	2095	17.2	5.0	1855	8.6	2.5	1380	8.6	2.5	1380	
1200	565	41.2	12.1	2370	32.9	9.6	2185	24.2	7.1	2000	17.5	5.1	1760	8.9	2.6	1285	8.9	2.6	1285	
1365	645	42.0	12.3	2300	33.7	9.9	2120	25.0	7.3	1935	18.3	5.4	1690	9.7	2.8	1215	9.7	2.8	1215	

Outdoor Temp.	°F	65	60	55	50	47	45	40	35	30	25	20	17	15	10	5	0	-5	-10	-15	-20
	°C	18	16	13	10	8	7	4	2	-1	-4	-7	-8	-9	-12	-15	-18	-21	-23	-26	-29
Compressor Motor kW Input		2.37	2.33	2.28	2.24	2.21	2.19	2.13	2.08	2.04	2	1.97	1.94	1.93	1.88	1.76	1.64	1.53	1.41	1.29	1.17
Total Output	kBtuh	41.2	39.3	37.3	35.3	34.2	32.9	29.7	26.5	25.4	24.2	23.1	22.4	21.6	19.7	17.5	15.4	13.2	11	8.9	6.7
	kW	12.1	11.5	10.9	10.3	10.0	9.6	8.7	7.8	7.4	7.1	6.8	6.6	6.3	5.8	5.1	4.5	3.9	3.2	2.6	2.0

	Inputs					
	Cap	Watts	Cap	Watts	Cap	Watts
	Low	Med	High			
CFM	1035	1200	1365			
47°F	33877.627	2303.35	34163.927	2209.063	34954.687	2139.676
35°F	---	---	26527.009	2077.292	---	---
17°F	---	---	22412.463	1942.081	---	---

HEATING PERFORMANCE EXTENDED RATINGS

4HP16L42P-50 - BCE7E42

Indoor Coil Air Volume 70°F db (28°C db)		Air Temperature Entering Outdoor Coil																		
		65°F (18°C)				45°F (7°C)				25°F (-4°C)				5°F (-15°C)			-15°F (-28°C)			
		Total Heating Capacity		Comp. Motor Watts Input		Total Heating Capacity		Comp. Motor Watts Input		Total Heating Capacity		Comp. Motor Watts Input		Total Heating Capacity		Comp. Motor Watts Input	Total Heating Capacity		Comp. Motor Watts Input	
CFM	L/s	kBtuh	kW	kBtuh	kW	kBtuh	kW	kBtuh	kW	kBtuh	kW	kBtuh	kW	kBtuh	kW	kBtuh	kW	kBtuh	kW	
1225	580	47.8	14.0	2990	37.5	11.0	2730	26.8	7.9	2460	18.2	5.3	2160	9.3	2.7	1605				
1400	660	48.0	14.1	2890	37.6	11.0	2630	27.0	7.9	2365	18.3	5.4	2060	9.4	2.8	1510				
1570	740	48.8	14.3	2805	38.4	11.3	2545	27.8	8.1	2280	19.1	5.6	1975	10.2	3.0	1425				

Outdoor Temp.	°F	65	60	55	50	47	45	40	35	30	25	20	17	15	10	5	0	-5	-10	-15	-20
	°C	18	16	13	10	8	7	4	2	-1	-4	-7	-8	-9	-12	-15	-18	-21	-23	-26	-29
Compressor Motor kW Input		2.89	2.83	2.77	2.7	2.67	2.63	2.55	2.46	2.42	2.37	2.32	2.29	2.26	2.2	2.06	1.92	1.79	1.65	1.51	1.37
Total Output	kBtuh	48	45.5	43	40.5	39	37.6	34.1	30.7	28.8	27	25.1	24	23	20.6	18.3	16.1	13.9	11.7	9.4	7.2
	kW	14.1	13.3	12.6	11.9	11.4	11.0	10.0	9.0	8.4	7.9	7.4	7.0	6.7	6.0	5.4	4.7	4.1	3.4	2.8	2.1

	Inputs											
	Cap	6.2		5.9		5.6		5.3		5.1		
	Low		Med				High					
CFM	1225		1400				1570					
47°F	38863.063		2761.168		39020.672		2663.106		39801.111		2579.208	
35°F	---		---		30658.706		2462.384		---		---	
17°F	---		---		24047.273		2285.758		---		---	

4HP16L48P-50 - BCE7E48

Indoor Coil Air Volume 70°F db (28°C db)		Air Temperature Entering Outdoor Coil																		
		65°F (18°C)				45°F (7°C)				25°F (-4°C)				5°F (-15°C)			-15°F (-28°C)			
		Total Heating Capacity		Comp. Motor Watts Input		Total Heating Capacity		Comp. Motor Watts Input		Total Heating Capacity		Comp. Motor Watts Input		Total Heating Capacity		Comp. Motor Watts Input	Total Heating Capacity		Comp. Motor Watts Input	
CFM	L/s	kBtuh	kW	kBtuh	kW	kBtuh	kW	kBtuh	kW	kBtuh	kW	kBtuh	kW	kBtuh	kW	kBtuh	kW	kBtuh	kW	
1370	645	51.7	15.2	3115	41.5	12.2	2895	31.0	9.1	2675	22.3	6.5	2360	11.2	3.3	1735				
1470	695	51.8	15.2	3060	41.7	12.2	2840	31.2	9.1	2620	22.4	6.6	2305	11.3	3.3	1680				
1715	810	52.4	15.4	2935	42.2	12.4	2715	31.8	9.3	2495	23.0	6.7	2180	11.9	3.5	1555				

Outdoor Temp.	°F	65	60	55	50	47	45	40	35	30	25	20	17	15	10	5	0	-5	-10	-15	-20
	°C	18	16	13	10	8	7	4	2	-1	-4	-7	-8	-9	-12	-15	-18	-21	-23	-26	-29
Compressor Motor kW Input		3.06	3.01	2.95	2.9	2.86	2.84	2.78	2.72	2.67	2.62	2.57	2.54	2.52	2.46	2.31	2.15	1.99	1.84	1.68	1.52
Total Output	kBtuh	51.8	49.4	47	44.6	43.1	41.7	38	34.4	32.8	31.2	29.6	28.6	27.6	25.2	22.4	19.7	16.9	14.1	11.3	8.6
	kW	15.2	14.5	13.8	13.1	12.6	12.2	11.1	10.1	9.6	9.1	8.7	8.4	8.1	7.4	6.6	5.8	5.0	4.1	3.3	2.5

	Inputs											
	Cap	Watts		Cap	Watts		Cap	Watts				
	Low		Med				High					
CFM	1370		1470				1715					
47°F	42955.533		2918.706		43100.509		2862.377		43688.681		2740.461	
35°F	---		---		34413.286		2720.21		---		---	
17°F	---		---		28593.374		2536.826		---		---	

HEATING PERFORMANCE EXTENDED RATINGS

4HP16L60P-50 - BCE7E60

Indoor Coil Air Volume 70°F db (28°C db)		Air Temperature Entering Outdoor Coil																			
		65°F (18°C)				45°F (7°C)				25°F (-4°C)				5°F (-15°C)				-15°F (-28°C)			
		Total Heating Capacity		Comp. Motor Watts Input		Total Heating Capacity		Comp. Motor Watts Input		Total Heating Capacity		Comp. Motor Watts Input		Total Heating Capacity		Comp. Motor Watts Input		Total Heating Capacity		Comp. Motor Watts Input	
CFM	L/s	kBtuh	kW	kBtuh	kW	kBtuh	kW	kBtuh	kW	kBtuh	kW	kBtuh	kW	kBtuh	kW	kBtuh	kW	kBtuh	kW		
1440	680	63.6	18.6	4080	50.7	14.9	3765	37.2	10.9	3445	27.6	8.1	3035	14.0	4.1	2250					
1600	755	63.6	18.6	3965	50.7	14.9	3650	37.2	10.9	3330	27.6	8.1	2925	13.9	4.1	2135					
1750	825	64.6	18.9	3860	51.7	15.2	3545	38.1	11.2	3225	28.6	8.4	2815	14.9	4.4	2030					

Outdoor Temp.	°F	65	60	55	50	47	45	40	35	30	25	20	17	15	10	5	0	-5	-10	-15	-20
	°C	18	16	13	10	8	7	4	2	-1	-4	-7	-8	-9	-12	-15	-18	-21	-23	-26	-29
Compressor Motor kW Input		3.97	3.89	3.82	3.74	3.69	3.65	3.56	3.46	3.4	3.33	3.27	3.23	3.2	3.12	2.93	2.73	2.53	2.33	2.14	1.94
Total Output	kBtuh	63.6	60.6	57.7	54.7	52.9	50.7	45.2	39.7	38.4	37.2	35.9	35.1	33.9	31	27.6	24.2	20.8	17.4	13.9	10.5
	kW	18.6	17.8	16.9	16.0	15.5	14.9	13.2	11.6	11.3	10.9	10.5	10.3	9.9	9.1	8.1	7.1	6.1	5.1	4.1	3.1

	Inputs					
	Cap	6.2	5.9	5.6	5.3	5.1
	Low		Med		High	
CFM	1440		1600		1750	
47°F	52949.719	3804.103	52910.3	3690.369	53890.233	3583.779
35°F	---	---	39711.9	3457.882	---	---
17°F	---	---	35128.484	3228.598	---	---



1-800-448-5872

All specifications and illustrations subject to change without notice and without incurring obligations.