



TECHNICAL GUIDE

LX SERIES SPLIT SYSTEM AIR CONDITIONERS 14 SEER – R-410A – 1 PHASE 1.5 THRU 5 NOMINAL TONS MODELS: TW4B18 THRU 60

FOR INSTALLATION IN ALL US REGIONS AND CANADA



Due to continuous product improvement, specifications are subject to change without notice.

Visit us on the web at

www.simplygettingthejobdone.com and
www.colemanac.com

Additional rating information can be found at
www.ahridirectory.org

WARRANTY SUMMARY*

Standard 5-year limited parts warranty.

Standard 10-year limited compressor warranty.

Extended 10-Years limited parts warranty when product is registered online within 90 days of purchase for replacement or closing for new home construction.

*Does not apply to R-22 models, 3-Phase models, or internet sales.

See Limited Warranty certificate in User's Information Manual for details.

DESCRIPTION

The TW4B models are optimized for 14 SEER Regional Minimum Efficiency and the high EER required in the Southwest US, these outdoor units are specifically designed to be matched with Coleman indoor coils, furnaces, and air handlers to provide a complete system solution.

FEATURES

- **Small Footprint** - Minimum footprint for easier handling, transportation, and installation.
- **Easier Installation** - Independent panels provide quick access for unit setup. Installation time is reduced by easy power and control wiring access. Select indoor matches with factory-mounted TXVs are available for quicker system installation. The factory installed filter-drier and factory charge for a 15-Ft lineset means less time spent brazing and charging the system. The small base dimension and reduced unit clearances make for easier retrofits.
- **Accessible Information** - QR code on unit provides quick access to technical documents and warranty information.
- **Durable Finish** - The coated steel wire fan guard, coated external fasteners, and pre-treated G90-equivalent galvanized steel chassis components resist corrosion and rust creep. Titanium colored powdercoat paint further protects external panels.
- **Quality Coils** - The high efficiency microchannel aluminum coil is manufactured using an improved material system providing reliable performance and small unit size.
- **Rugged Coil Protection** - Coils are protected from mechanical damage by a proven stamped steel coil guard design.
- **Protected Compressor** - Compressors are protected internally by a high pressure relief valve and a temperature sensor, and externally by the system high pressure switch. The liquid line filter-drier is factory installed to protect the compressor against moisture and debris.
- **Reliable Operation** - Ball bearing fan motors provide superior performance in extreme temperatures.
- **Environmentally Friendly** - CFC-free R-410A refrigerant delivers environmentally friendly performance with zero ozone depletion.
- **Top Discharge** - Warm air is blown up, away from the structure and any landscaping and allows compact location on multi-unit applications.
- **Low Operating Sound Levels** - Developed using CFD and FEA tools, the sturdy cabinet and top design provides sound performance of 76 dBA or lower. Compatible accessories for further sound reduction are also available.
- **Better Service Access** - Diagonal base valves with open access for low-loss fittings, single panel access to the electrical controls, swing out control box for full corner access, and removable fan guard allow easy access for unit maintenance.
- **Agency Listed** - Safety certified by CSA to UL 1995 / CSA 22.2. Performance certified to ANSI/AHRI Standard 210/240 in accordance with the Unitary Small Equipment certification program.

LIST OF SECTIONS

DESCRIPTION	1
FEATURES	1
NOMENCLATURE	2
PHYSICAL AND ELECTRICAL DATA	3
DIMENSIONS	3
SYSTEM CHARGE FOR VARIOUS MATCHED SYSTEMS	4
COOLING CAPACITY - With Air Handler Coils	5
COOLING CAPACITY - Upflow, Downflow & Horizontal Furnaces and Coils (Coil Only Ratings)	9
COOLING CAPACITY - With High Efficiency Motor Furnaces ..	10
APPLICATIONS AND ACCESSORIES	59
SOUND POWER RATINGS	59
MECHANICAL SPECIFICATIONS	60
TYPICAL INSTALLATION	61
TYPICAL FIELD WIRING	62
ALTERNATIVE INSTALLATION CLEARANCES	62
PERFORMANCE DATA - 1.5 TON	63
PERFORMANCE DATA - 2 TON	67
PERFORMANCE DATA - 2.5 TON	72
PERFORMANCE DATA - 3 TON	77
PERFORMANCE DATA - 3.5 TON	83
PERFORMANCE DATA - 4 TON	89
PERFORMANCE DATA - 5 TON	94

NOMENCLATURE

BRAND	T	T = Factory Branded
PRODUCT TYPE	W	C = Air Conditioner (US Northern or Southeast Region)
NOMINAL SERIES EFFICIENCY AND STAGING	4	4 = 14 SEER / 1-Stage (US Southeast or Southwest Region)
REFRIGERANT	B	B = R-410A
NOMINAL UNIT CAPACITY (MBH)	36	18 = 1.5 Ton 42 = 3.5 Ton 24 = 2 Ton 48 = 4 Ton 30 = 2.5 Ton 60 = 5 Ton 36 = 3 Ton
VOLTAGE (Voltage-Phase-Hertz)	2	2 = 208/230-1-60
GENERATION (MAJOR REVISION)	1	1 = 1st Gen 2 = 2nd Gen etc
FACTORY OPTION	S	S = Standard (No Options)
STYLE LETTER (Minor Revision) Not Used for Ordering	A	A = Style A B = Style B

PHYSICAL AND ELECTRICAL DATA

MODEL		TW4B1821S	TW4B2421S	TW4B3021S	TW4B3621S	TW4B4221S	TW4B4821S	TW4B6021S
Unit Supply Voltage		208-230V, 1 ϕ , 60Hz						
Normal Voltage Range ¹		187 to 252						
Minimum Circuit Ampacity		11.8	13.6	17.6	20.5	22.1	25.7	31.7
Max. Overcurrent Device Amps ²		20	20	30	35	35	45	50
Min. Overcurrent Device Amps ³		15	15	20	25	25	30	35
Compressor Type		Scroll	Scroll	Scroll	Scroll	Scroll	Scroll	Scroll
Compressor	Rated Load	9.0	10.2	13.4	15.4	16.6	19.5	24.3
	Locked Rotor	56.3	61.6	72.5	83.9	109.0	130.0	144.2
Crankcase Heater		No	No	No	No	No	No	No
Factory External Discharge Muffler		No	No	No	No	No	No	No
HS Kit Required with TXV ⁴		No	No	No	No	No	No	No
Fan Diameter Inches		18	22	22	22	24	24	26
Fan Motor	Rated HP	1/12	1/8	1/8	1/4	1/4	1/4	1/4
	Rated Load Amps	0.64	0.80	0.80	1.3	1.3	1.3	1.3
	Nominal RPM	1000	1075	1075	850	850	850	850
	Nominal CFM	1900	2875	2950	3275	3500	3500	4300
Coil	Face Area Sq. Ft.	12.37	13.83	13.83	17.37	18.74	18.74	23.40
	Rows Deep	1	1	1	1	1	1	1
	Fins / Inch	23	23	23	23	23	23	23
Liquid Line Set OD (Field Installed)		3/8	3/8	3/8	3/8	3/8	3/8	3/8
Vapor Line Set OD (Field Installed) ⁵		3/4	3/4	3/4	3/4	7/8	7/8	1-1/8 [‡]
Unit Charge (Lbs. - Oz.) ⁶		3-6	3-12	3-15	4-10	4-15	4 - 15	5 - 12
Charge Per Foot, Oz.		0.62	0.62	0.62	0.62	0.67	0.67	0.75
Operating Weight Lbs.		130	135	140	155	200	200	205

1. Rated in accordance with AHRI Standard 110-2012, utilization range "A".
2. Dual element fuses or HACR circuit breaker. Maximum allowable overcurrent protection.
3. Dual element fuses or HACR circuit breaker. Minimum recommended overcurrent protection.
4. See Hard Start Kit Accessory Installation Manual for Hard Start Kit part number for each model.
5. For applications with non-standard vapor line sizes, see the "Applications & Accessories" section of this Technical Guide.
6. The Unit Charge is correct for the outdoor unit, smallest matched indoor unit, and 15 feet of refrigerant tubing. For tubing lengths other than 15 feet, add or subtract the amount of refrigerant, using the difference in actual lineset length (not equivalent length) multiplied by the per foot value.

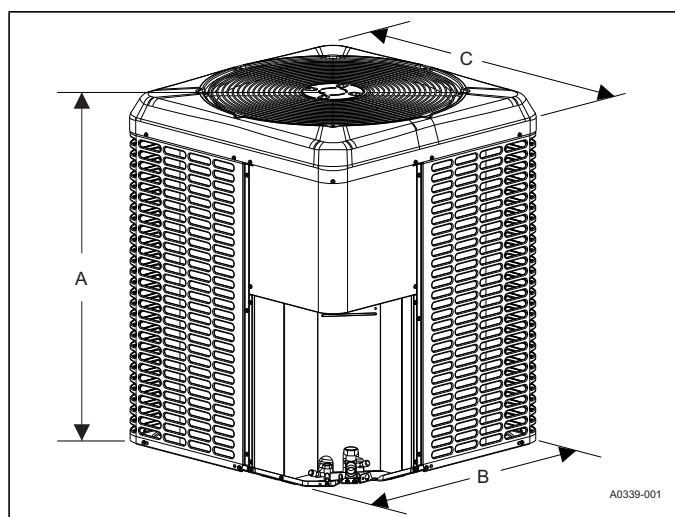

DIMENSIONS

Unit Model	Dimensions (Inches)			Refrigerant Connection Service Valve Size	
	A	B	C	Liquid	Vapor
TW4B1821S	33-1/4	24	24	3/8	3/4
TW4B2421S	30	29-1/4	29-1/4		
TW4B3021S	30	29-1/4	29-1/4		
TW4B3621S	36-1/4	29-1/4	29-1/4		
TW4B4221S	33-1/4	35-1/4	31-3/4	7/8	7/8 [‡]
TW4B4821S	33-1/4	35-1/4	31-3/4		
TW4B6021S	36-1/4	38	34-1/4		

‡ Adapter fitting must be field installed for the required 1-1/8" line set.
 All dimensions are in inches and are subject to change without notice.
 Overall height is from bottom of base pan to top of fan guard.
 Overall length and width include screw heads.

SYSTEM CHARGE FOR VARIOUS MATCHED SYSTEMS

Outdoor Unit	TW4B1821S	TW4B2421S	TW4B3021S	TW4B3621S	TW4B4221S	TW4B4821S	TW4B6021S
Required TXV ^{1,2}	BA1 or BH1	BA1	BB1	BC1	BC1	BC1	BD1
Indoor Unit ^{3,4,5}	Additional Charge, oz						
AP18B	0	–	–	–	–	–	–
AP24B	3	0	–	–	–	–	–
AP30B	10	7	2	–	–	–	–
AP36B	10	7	2	0	–	–	–
AP36C	–	11	2	2	–	–	–
AP42C	–	11	2	2	0	–	–
AP48(C,D)	–	–	–	5	2	0	–
AP60(C,D)	–	–	–	–	9	2	0
AE18B	0	–	–	–	–	–	–
AE24B	3	0	–	–	–	–	–
AE30B	8	5	0	–	–	–	–
AE36(B,C)	10	7	2	0	–	–	–
AE42C	–	–	–	5	2	–	–
AE48(C,D)	–	–	–	5	2	0	–
AE60C	–	–	–	–	9	2	0
AE60D	–	–	–	–	29	22	20
AVC18B	0	–	–	–	–	–	–
AVC24B	3	0	–	–	–	–	–
AVC30B	8	5	0	–	–	–	–
AVC36(B,C)	10	7	2	0	–	–	–
AVC42C	–	–	–	5	2	–	–
AVC48(C,D)	–	–	–	5	2	0	–
AVC60C	–	–	–	–	9	2	0
AVC60D	–	–	–	–	29	22	20
CF/CM/CU18(A,B)	0	–	–	–	–	–	–
CF/CM/CU24(A,B)	3	0	–	–	–	–	–
CF/CM/CU30(A,B,C)	8	5	0	–	–	–	–
CF/CM/CU36(A,B,C,D)	10	7	2	0	–	–	–
CF/CM/CU42(B,C,D)	–	11	2	2	0	–	–
CF/CM/CU48(C,D)	–	–	–	5	2	0	–
CF/CM/CU60(C,D)	–	–	–	–	9	2	0
CF/CM64D	–	–	–	–	29	22	20

Some of the combinations shown in the above System Charge table require Advanced Main Air Circulating Fan indoor product. For approved coil only matches, please see the "COOLING CAPACITY - Upflow, Downflow & Horizontal Furnaces and Coils" table.

FOOTNOTES:

1. For applications requiring a TXV, use S1-1TVM*** series kit.
2. A TXV kit must be used with these indoor units to obtain system performance.
3. Systems matched with furnaces or air handlers not equipped with blower-off delays may require 60 second time delay.
4. CF coils cannot be used in horizontal applications.
5. Charge adders shown above do not indicate that coils are rated for every application. Refer to Performance Data Tables for actual performance for specified system matches. Obtain certified system ratings from www.ahridirectory.org.

CHARGING PROCEDURES:

1. Check the Factory Unit Charge listed on the unit nameplate to verify the refrigerant charge for the outdoor unit, the smallest matched indoor unit, and the 15 feet of interconnecting lineset.
2. Verify the indoor metering device and additional charge required for the specific matched indoor unit in the system using the above table.
3. Add additional charge for the amount of interconnecting lineset greater than 15 feet at the rate specified in the Physical and Electrical Table.
4. For installations requiring additional charge, weigh in refrigerant for the specific matching indoor unit and actual lineset length.
5. Once the charge adders for matched indoor unit and for lineset have been weighed in, verify the system operation against the temperatures and pressures in the Charging Chart for the outdoor unit. Locate Charging Charts on the outdoor unit and also in the Service Data Application Guide on www.simplygettingthejobdone.com. Follow the Subcool or the Superheat charging procedure in the Installation Manual according to the type of indoor metering device in the system, and allow ten minutes after each charge adjustment for the system operation to stabilize. Record the charge adjustment made to match the Charging Chart.
6. Permanently stamp the unit data plate with the TOTAL SYSTEM CHARGE defined as follows: TOTAL SYSTEM CHARGE = Base Charge (as shipped) + charge adder for matched indoor unit + charge adder for actual lineset length + charge adjustments to match the Charging Chart.

COOLING CAPACITY - With Air Handler Coils

UNIT MODEL	AIR HANDLER		COIL MODEL ¹	COOLING				
	MODEL	WIDTH		RATED CFM	NET MBH		SEER	EER
					TOTAL	SENS.		
TW4B1821S	AE18BX21	17.5	–	600	18.0	12.1	16.25	13.25
TW4B1821S	AE24BX21	17.5	–	600	18.0	12.0	16.25	13.25
TW4B1821S	AE30BX21	17.5	–	600	18.0	12.2	16.25	13.25
TW4B1821S	AE36BX21	17.5	–	600	18.0	12.0	15.75	12.75
TW4B1821S	AE36CX21	21.0	–	600	18.0	12.1	16.00	13.00
TW4B1821S	AP18BX21	17.5	–	600	18.0	12.1	14.75	12.50
TW4B1821S	AP24BX21	17.5	–	600	18.0	12.0	14.50	12.25
TW4B1821S	AP30BX21	17.5	–	600	18.0	12.3	14.75	12.25
TW4B1821S	AVC18BX21	17.5	–	600	18.0	12.1	16.25	13.25
TW4B1821S	AVC24BX21	17.5	–	600	18.0	12.1	16.25	13.25
TW4B1821S	AVC30BX21	17.5	–	600	18.0	12.0	16.25	13.25
TW4B1821S	ME08BN21	17.5	CF/CM18B	600	18.0	12.1	16.25	13.25
TW4B1821S	ME08BN21	17.5	CF/CM24B	600	18.0	12.2	16.25	13.25
TW4B1821S	ME08BN21	17.5	CF/CM30B	600	18.0	12.0	16.25	13.25
TW4B1821S	ME08BN21	17.5	CF/CM36B	600	18.0	12.3	16.25	13.25
TW4B1821S	ME12BN21	17.5	CF/CM18B	600	18.0	12.1	15.00	12.50
TW4B1821S	ME12BN21	17.5	CF/CM24B	625	18.0	12.3	15.25	12.50
TW4B1821S	ME12BN21	17.5	CF/CM30B	625	18.0	12.2	15.75	12.75
TW4B1821S	ME12BN21	17.5	CF/CM36B	650	18.0	12.5	16.00	13.00
TW4B1821S	MVC08BN21	17.5	CF/CM18B	550	18.0	11.7	16.25	13.25
TW4B1821S	MVC08BN21	17.5	CF/CM24B	575	18.0	12.0	16.25	13.25
TW4B1821S	MVC08BN21	17.5	CF/CM30B	600	18.0	12.0	16.25	13.25
TW4B1821S	MVC12BN21	17.5	CF/CM36B	675	18.0	12.5	16.25	13.25
TW4B2421S	AE24BX21	17.5	–	800	24.0	16.8	16.25	13.25
TW4B2421S	AE30BX21	17.5	–	800	24.0	16.8	16.25	13.25
TW4B2421S	AE36BX21	17.5	–	800	24.0	16.8	16.25	13.25
TW4B2421S	AE36CX21	21.0	–	800	24.0	16.8	16.25	13.25
TW4B2421S	AP24BX21	17.5	–	800	24.0	16.8	14.25	12.25
TW4B2421S	AP30BX21	17.5	–	800	24.0	16.6	15.25	12.50
TW4B2421S	AP36BX21	17.5	–	900	24.0	17.4	14.50	12.25
TW4B2421S	AP36CX21	21.0	–	850	24.0	17.0	14.75	12.50
TW4B2421S	AVC24BX21	17.5	–	750	24.0	16.4	15.75	13.00
TW4B2421S	AVC30BX21	17.5	–	775	24.0	16.6	16.25	13.25
TW4B2421S	AVC36BX21	17.5	–	800	24.0	16.6	16.25	13.25
TW4B2421S	AVC36CX21	21.0	–	800	24.0	16.8	16.25	13.25
TW4B2421S	ME08BN21	17.5	CF/CM24B	800	24.0	16.8	16.25	13.25
TW4B2421S	ME08BN21	17.5	CF/CM30B	800	24.0	17.0	16.25	13.25
TW4B2421S	ME08BN21	17.5	CF/CM36B	800	24.0	16.6	16.25	13.25
TW4B2421S	ME08BN21	17.5	CF42B	800	24.0	16.8	16.25	13.25
TW4B2421S	ME12BN21	17.5	CF/CM24B	800	24.0	16.8	16.00	13.00
TW4B2421S	ME12BN21	17.5	CF/CM30B	800	24.0	16.8	16.25	13.25
TW4B2421S	ME12BN21	17.5	CF/CM36B	800	24.0	16.6	16.25	13.25
TW4B2421S	ME12BN21	17.5	CF42B	800	24.0	16.8	16.25	13.25
TW4B2421S	ME14DN21	24.5	CF/CM30D	800	24.0	16.8	16.00	13.00
TW4B2421S	ME14DN21	24.5	CF/CM36D	800	24.0	16.6	16.00	13.00
TW4B2421S	ME14DN21	24.5	CF/CM42D	800	24.0	16.8	16.00	13.00
TW4B2421S	ME16CN21	21.0	CF/CM24C	875	24.0	17.4	14.75	12.50
TW4B2421S	MVC08BN21	17.5	CF/CM24B	800	24.0	16.8	16.25	13.25
TW4B2421S	MVC08BN21	17.5	CF/CM30B	700	24.0	16.2	16.25	13.25

COOLING CAPACITY - With Air Handler Coils (Continued)

UNIT MODEL	AIR HANDLER		COIL MODEL ¹	COOLING				
	MODEL	WIDTH		RATED CFM	NET MBH		SEER	EER
					TOTAL	SENS.		
TW4B2421S	MVC08BN21	17.5	CF/CM36B	775	24.0	16.6	16.25	13.25
TW4B2421S	MVC08BN21	17.5	CF42B	800	24.0	16.8	16.25	13.25
TW4B2421S	MVC12BN21	17.5	CF/CM24B	800	24.0	16.8	16.00	13.00
TW4B2421S	MVC12BN21	17.5	CF/CM30B	850	24.0	17.2	16.25	13.25
TW4B2421S	MVC12BN21	17.5	CF/CM36B	775	24.0	16.6	16.25	13.25
TW4B2421S	MVC12BN21	17.5	CF42B	800	24.0	16.8	16.25	13.25
TW4B2421S	MVC14DN21	24.5	CF/CM30D	800	24.0	16.8	16.25	13.25
TW4B2421S	MVC14DN21	24.5	CF/CM36D	850	24.0	17.2	16.25	13.25
TW4B2421S	MVC14DN21	24.5	CF/CM42D	825	24.0	16.8	16.25	13.25
TW4B2421S	MVC16CN21	21.0	CF/CM42C	900	24.0	17.4	16.25	13.25
TW4B3021S	AE30BX21	17.5	–	1000	29.4	21.0	15.00	12.50
TW4B3021S	AE36BX21	17.5	–	975	29.8	21.2	15.25	12.75
TW4B3021S	AE36CX21	21.0	–	1000	30.0	21.2	15.75	13.00
TW4B3021S	AP30BX21	17.5	–	1000	29.4	20.6	14.00	12.25
TW4B3021S	AP36BX21	17.5	–	1000	29.2	20.6	14.00	12.25
TW4B3021S	AP36CX21	21.0	–	1000	29.2	20.6	14.00	12.25
TW4B3021S	AP42CX21	21.0	–	1100	29.6	21.6	14.00	12.25
TW4B3021S	AVC30BX21	17.5	–	975	29.4	20.8	15.00	12.50
TW4B3021S	AVC36BX21	17.5	–	975	30.0	21.4	15.75	13.00
TW4B3021S	AVC36CX21	21.0	–	975	30.0	21.6	16.00	13.00
TW4B3021S	ME08BN21	17.5	CF/CM30B	900	29.2	20.4	15.50	12.75
TW4B3021S	ME08BN21	17.5	CF/CM36B	900	29.4	20.0	15.75	13.00
TW4B3021S	ME08BN21	17.5	CF42B	875	29.4	19.8	15.50	12.75
TW4B3021S	ME12BN21	17.5	CF/CM30B	825	28.6	19.0	15.50	12.75
TW4B3021S	ME12BN21	17.5	CF/CM36B	1025	29.8	21.4	15.50	12.75
TW4B3021S	ME12BN21	17.5	CF42B	975	29.8	21.0	15.25	12.75
TW4B3021S	ME14DN21	24.5	CF/CM30D	1050	30.0	21.8	16.00	13.00
TW4B3021S	ME14DN21	24.5	CF/CM36D	1025	30.0	21.6	16.00	13.00
TW4B3021S	ME14DN21	24.5	CF/CM42D	1000	30.0	21.0	16.00	13.00
TW4B3021S	ME16CN21	21.0	CF/CM30C	1075	29.6	21.8	15.00	12.50
TW4B3021S	ME16CN21	21.0	CF/CM36C	1100	30.0	22.0	15.25	12.50
TW4B3021S	ME16CN21	21.0	CF/CM42C	1000	29.6	20.8	14.75	12.50
TW4B3021S	MVC08BN21	17.5	CF42B	825	29.0	19.2	15.50	12.75
TW4B3021S	MVC12BN21	17.5	CF/CM30B	850	28.6	19.0	15.25	12.50
TW4B3021S	MVC12BN21	17.5	CF/CM36B	1000	29.6	21.0	15.00	12.50
TW4B3021S	MVC12BN21	17.5	CF42B	975	29.6	21.0	15.25	12.50
TW4B3021S	MVC14DN21	24.5	CF/CM30D	925	29.4	20.4	16.00	13.00
TW4B3021S	MVC14DN21	24.5	CF/CM36D	975	29.8	21.0	16.00	13.00
TW4B3021S	MVC14DN21	24.5	CF/CM42D	1000	30.0	21.0	16.00	13.00
TW4B3021S	MVC16CN21	21.0	CF/CM30C	925	29.2	20.4	15.75	13.00
TW4B3021S	MVC16CN21	21.0	CF/CM36C	1025	30.0	21.6	16.00	13.00
TW4B3021S	MVC16CN21	21.0	CF/CM42C	900	29.6	20.2	16.00	13.00
TW4B3021S	MVC20DN21	24.5	CF/CM36D	1120	30.0	22.2	16.00	13.00
TW4B3021S	MVC20DN21	24.5	CF/CM42D	1100	30.0	22.0	15.50	12.75
TW4B3621S	AE36BX21	17.5	–	1000	36.0	24.0	15.25	12.50
TW4B3621S	AE36CX21	21.0	–	1225	36.0	26.0	15.75	13.00
TW4B3621S	AE42CX21	21.0	–	1200	36.0	25.6	15.50	12.75
TW4B3621S	AE48CX21	21.0	–	1250	36.0	26.0	15.75	13.00
TW4B3621S	AE48DX21	24.5	–	1225	36.0	25.8	16.00	13.00

COOLING CAPACITY - With Air Handler Coils (Continued)

UNIT MODEL	AIR HANDLER		COIL MODEL ¹	COOLING				
	MODEL	WIDTH		RATED CFM	NET MBH		SEER	EER
					TOTAL	SENS.		
TW4B3621S	AP36BX21	17.5	–	1000	35.4	23.6	14.00	12.25
TW4B3621S	AP36CX21	21.0	–	1225	36.0	25.8	14.25	12.25
TW4B3621S	AP42CX21	21.0	–	1225	36.0	26.0	14.00	12.25
TW4B3621S	AP48CX21	21.0	–	1200	36.0	25.4	14.25	12.25
TW4B3621S	AP48DX21	24.5	–	1325	36.0	26.6	14.25	12.25
TW4B3621S	AVC36BX21	17.5	–	1025	36.0	24.0	15.25	12.50
TW4B3621S	AVC36CX21	21.0	–	1125	36.0	25.4	15.75	13.00
TW4B3621S	AVC42CX21	21.0	–	1100	36.0	25.2	16.00	13.00
TW4B3621S	AVC48CX21	21.0	–	1075	36.0	24.6	15.75	13.00
TW4B3621S	AVC48DX21	24.5	–	1350	36.0	26.8	16.00	13.00
TW4B3621S	ME12BN21	17.5	CF/CM36B	1025	36.0	24.0	15.25	12.50
TW4B3621S	ME12BN21	17.5	CF42B	975	36.0	24.0	15.25	12.50
TW4B3621S	ME14DN21	24.5	CF/CM36D	1250	36.0	26.2	16.00	13.00
TW4B3621S	ME14DN21	24.5	CF/CM42D	1225	36.0	26.0	16.00	13.00
TW4B3621S	ME14DN21	24.5	CF/CM48D	1200	36.0	25.6	16.00	13.00
TW4B3621S	ME16CN21	21.0	CF/CM36C	1225	36.0	26.0	15.75	13.00
TW4B3621S	ME16CN21	21.0	CF/CM42C	1225	36.0	25.8	15.75	13.00
TW4B3621S	ME16CN21	21.0	CF/CM48C	1225	36.0	25.8	16.00	13.00
TW4B3621S	ME20DN21	24.5	CF/CM36D	1325	36.0	26.8	15.00	12.50
TW4B3621S	ME20DN21	24.5	CF/CM42D	1325	36.0	26.8	15.00	12.50
TW4B3621S	ME20DN21	24.5	CF/CM48D	1325	36.0	26.6	15.00	12.50
TW4B3621S	MVC08BN21	17.5	CF42B	975	36.0	24.0	15.00	12.50
TW4B3621S	MVC12BN21	17.5	CF/CM36B	1025	36.0	24.0	14.75	12.50
TW4B3621S	MVC12BN21	17.5	CF42B	975	36.0	24.0	15.25	12.50
TW4B3621S	MVC14DN21	24.5	CF/CM36D	975	36.0	23.6	15.50	12.75
TW4B3621S	MVC14DN21	24.5	CF/CM42D	1275	36.0	26.2	15.75	13.00
TW4B3621S	MVC14DN21	24.5	CF/CM48D	1150	36.0	25.2	16.00	13.00
TW4B3621S	MVC16CN21	21.0	CF/CM36C	1100	36.0	24.8	15.75	13.00
TW4B3621S	MVC16CN21	21.0	CF/CM42C	1250	36.0	26.4	15.50	12.75
TW4B3621S	MVC16CN21	21.0	CF/CM48C	1200	36.0	25.4	15.75	13.00
TW4B3621S	MVC20DN21	24.5	CF/CM36D	1120	36.0	25.0	15.75	13.00
TW4B3621S	MVC20DN21	24.5	CF/CM42D	1200	36.0	25.6	15.50	12.75
TW4B3621S	MVC20DN21	24.5	CF/CM48D	1200	36.0	25.4	15.75	13.00
TW4B4221S	AE42CX21	21.0	–	1375	41.5	33.0	14.75	12.50
TW4B4221S	AE48CX21	21.0	–	1225	41.0	30.5	15.25	12.75
TW4B4221S	AE48DX21	24.5	–	1225	41.0	31.0	15.50	12.75
TW4B4221S	AE60CX21	21.0	–	1425	42.0	33.5	15.25	12.50
TW4B4221S	AE60DX21	24.5	–	1400	42.0	33.5	15.50	12.75
TW4B4221S	AP42CX21	21.0	–	1225	40.0	30.0	14.00	12.25
TW4B4221S	AP48CX21	21.0	–	1300	40.5	31.0	14.00	12.25
TW4B4221S	AP48DX21	24.5	–	1350	40.5	31.5	14.00	12.25
TW4B4221S	AVC42CX21	21.0	–	1275	41.0	31.0	15.00	12.50
TW4B4221S	AVC48CX21	21.0	–	1225	40.5	30.5	15.25	12.50
TW4B4221S	AVC48DX21	24.5	–	1300	41.5	32.0	15.50	12.75
TW4B4221S	AVC60CX21	21.0	–	1275	41.5	31.5	15.25	12.50
TW4B4221S	AVC60DX21	24.5	–	1200	41.5	30.5	15.50	12.75
TW4B4221S	ME14DN21	24.5	CF/CM42D	1400	41.5	33.0	15.25	12.75
TW4B4221S	ME14DN21	24.5	CF/CM48D	1400	41.5	33.0	15.25	12.50
TW4B4221S	ME14DN21	24.5	CF/CM60D	1225	41.5	31.0	15.75	13.00

COOLING CAPACITY - With Air Handler Coils (Continued)

UNIT MODEL	AIR HANDLER		COIL MODEL ¹	COOLING				
	MODEL	WIDTH		RATED CFM	NET MBH		SEER	EER
					TOTAL	SENS.		
TW4B4221S	ME14DN21	24.5	CF/CM64D	1375	42.0	33.0	14.75	12.50
TW4B4221S	ME16CN21	21.0	CF/CM42C	1400	41.0	33.0	15.00	12.50
TW4B4221S	ME16CN21	21.0	CF/CM48C	1225	41.0	30.5	15.50	12.75
TW4B4221S	ME16CN21	21.0	CF/CM60C	1225	41.5	31.0	15.75	13.00
TW4B4221S	ME20DN21	24.5	CF/CM42D	1450	41.5	33.5	15.25	12.50
TW4B4221S	ME20DN21	24.5	CF/CM48D	1475	42.0	34.0	15.25	12.75
TW4B4221S	ME20DN21	24.5	CF/CM60D	1425	42.0	33.0	15.25	12.75
TW4B4221S	ME20DN21	24.5	CF/CM64D	1400	42.0	33.0	15.25	12.75
TW4B4221S	MVC12BN21	17.5	CF42B	1175	40.0	29.0	14.25	12.25
TW4B4221S	MVC14DN21	24.5	CF/CM42D	1375	41.5	32.5	15.00	12.50
TW4B4221S	MVC14DN21	24.5	CF/CM48D	1325	41.5	32.0	15.25	12.75
TW4B4221S	MVC14DN21	24.5	CF/CM60D	1225	41.0	31.0	15.50	12.75
TW4B4221S	MVC16CN21	21.0	CF/CM42C	1250	41.0	31.0	15.25	12.75
TW4B4221S	MVC16CN21	21.0	CF/CM48C	1275	41.0	31.5	15.25	12.75
TW4B4221S	MVC20DN21	24.5	CF/CM42D	1225	40.5	30.5	15.00	12.50
TW4B4221S	MVC20DN21	24.5	CF/CM48D	1300	41.5	32.0	15.25	12.75
TW4B4221S	MVC20DN21	24.5	CF/CM60D	1250	41.5	31.5	15.75	13.00
TW4B4821S	AE48CX21	21.0	–	1425	48.0	34.5	15.75	12.75
TW4B4821S	AE48DX21	24.5	–	1425	48.0	34.5	16.00	13.00
TW4B4821S	AE60CX21	21.0	–	1425	48.0	35.0	15.75	12.75
TW4B4821S	AE60DX21	24.5	–	1400	48.0	34.5	16.25	13.25
TW4B4821S	AP48CX21	21.0	–	1300	48.0	33.5	14.50	12.00
TW4B4821S	AP48DX21	24.5	–	1600	47.5	34.0	14.00	11.75
TW4B4821S	AP60CX21	21.0	–	1600	48.0	36.5	14.50	12.00
TW4B4821S	AP60DX21	24.5	–	1600	48.0	36.0	14.50	12.00
TW4B4821S	AVC48CX21	21.0	–	1350	48.0	34.0	15.50	12.75
TW4B4821S	AVC48DX21	24.5	–	1350	48.0	34.5	16.00	13.00
TW4B4821S	AVC60CX21	21.0	–	1350	48.0	34.5	15.75	13.00
TW4B4821S	AVC60DX21	24.5	–	1475	48.0	35.0	15.75	13.00
TW4B4821S	ME14DN21	24.5	CF/CM60D	1425	48.0	34.5	16.00	13.00
TW4B4821S	ME14DN21	24.5	CF/CM64D	1375	48.0	34.0	16.00	13.00
TW4B4821S	ME16CN21	21.0	CF/CM48C	1475	48.0	35.5	15.75	13.00
TW4B4821S	ME16CN21	21.0	CF/CM60C	1450	48.0	35.0	16.00	13.00
TW4B4821S	ME20DN21	24.5	CF/CM48D	1475	48.0	35.5	16.00	13.00
TW4B4821S	ME20DN21	24.5	CF/CM60D	1400	48.0	34.5	15.75	12.75
TW4B4821S	ME20DN21	24.5	CF/CM64D	1425	48.0	35.0	16.00	13.00
TW4B4821S	MVC14DN21	24.5	CF/CM48D	1325	48.0	33.5	15.75	12.75
TW4B4821S	MVC14DN21	24.5	CF/CM60D	1350	48.0	33.5	15.75	12.75
TW4B4821S	MVC14DN21	24.5	CF/CM64D	1325	48.0	33.5	16.00	13.00
TW4B4821S	MVC16CN21	21.0	CF/CM48C	1425	48.0	34.5	15.75	12.75
TW4B4821S	MVC16CN21	21.0	CF/CM60C	1650	48.0	37.0	16.25	13.25
TW4B4821S	MVC20DN21	24.5	CF/CM48D	1450	48.0	35.0	15.75	12.75
TW4B4821S	MVC20DN21	24.5	CF/CM60D	1475	48.0	35.5	15.75	13.00
TW4B4821S	MVC20DN21	24.5	CF/CM64D	1375	48.0	34.0	16.00	13.00
TW4B6021S	AE60CX21	21.0	–	1625	56.0	40.0	14.25	12.00
TW4B6021S	AE60DX21	24.5	–	1775	57.5	42.0	14.25	12.25
TW4B6021S	AVC60CX21	21.0	–	1750	56.5	41.5	14.00	12.00
TW4B6021S	AVC60DX21	24.5	–	1650	57.5	41.0	14.75	12.25
TW4B6021S	ME16CN21	21.0	CF/CM60C	1625	56.0	40.0	14.50	12.25

COOLING CAPACITY - With Air Handler Coils (Continued)

UNIT MODEL	AIR HANDLER		COIL MODEL ¹	COOLING				
	MODEL	WIDTH		RATED CFM	NET MBH		SEER	EER
					TOTAL	SENS.		
TW4B6021S	ME20DN21	24.5	CF/CM60D	1650	56.5	40.0	14.50	12.25
TW4B6021S	ME20DN21	24.5	CF/CM64D	1625	57.5	40.5	14.75	12.25
TW4B6021S	MVC16CN21	21.0	CF/CM60C	1650	57.0	40.5	15.50	12.75
TW4B6021S	MVC20DN21	24.5	CF/CM60D	1700	56.0	40.0	14.50	12.25
TW4B6021S	MVC20DN21	24.5	CF/CM64D	1700	57.0	40.5	14.75	12.25

Rated in accordance with DOE test procedures (Federal Register 12-27-79 and 3-18-88) and ANSI/AHRI Standard 210/240.

Cooling MBH based on 80°F entering air temperature, 50% RH (Relative Humidity), and rated air flow.

EER (Energy Efficiency Ratio) is the total cooling output in BTUs at 95°F outdoor ambient divided by the total electric power in watt-hours at those conditions.

SEER (Seasonal Energy Efficiency Ratio) is the total cooling output in BTUs during a normal annual usage period for cooling divided by the total electric power input in watt-hours during the same period.

1. CM coils available with a factory installed horizontal drain pan. See price pages for specific model number.

— = Not applicable.

MP Modular Air Handlers use Coil Only Ratings.

COOLING CAPACITY - Upflow, Downflow & Horizontal Furnaces and Coils (Coil Only Ratings)

UNIT MODEL	COIL		CFM RANGE (MIN.-MAX.)	COOLING				
	MODEL	WIDTH		RATED CFM	NET MBH		SEER ¹	EER
					TOTAL	SENS.		
TW4B1821S	CF/CM/CU18A	14.5	450 - 750	600	18.0	12.0	14.00	12.20
TW4B1821S	CF/CM/CU18B	17.5	450 - 750	600	18.0	12.0	14.25	12.25
TW4B1821S	CF/CM/CU24A	14.5	450 - 750	600	18.0	12.0	14.50	12.25
TW4B1821S	CF/CM/CU24B	17.5	450 - 750	600	18.0	12.0	14.50	12.25
TW4B1821S	CF/CM/CU24C	21	450 - 750	600	18.0	12.0	14.50	12.25
TW4B1821S	CF/CM/CU30A	14.5	450 - 750	600	18.0	11.9	14.50	12.25
TW4B1821S	CF/CM/CU30B	17.5	450 - 750	600	18.0	11.9	14.50	12.25
TW4B1821S	CF/CM/CU30C	21	450 - 750	600	18.0	11.9	14.50	12.25
TW4B1821S	CF/CM/CU30D	24.5	450 - 750	600	18.0	11.9	14.50	12.25
TW4B1821S	CF/CM/CU36B	17.5	450 - 750	600	18.0	12.3	14.75	12.25
TW4B1821S	CF/CM/CU36C	21	450 - 750	600	18.0	12.3	14.75	12.25
TW4B1821S	CF/CM/CU36D	24.5	450 - 750	600	18.0	12.3	14.75	12.25
TW4B1821S	CF/CM36A	14.5	450 - 750	600	18.0	12.3	14.75	12.25
TW4B2421S	CF/CM/CU24A	14.5	600 - 1000	800	24.0	16.8	14.00	12.20
TW4B2421S	CF/CM/CU24B	17.5	600 - 1000	800	24.0	16.8	14.25	12.25
TW4B2421S	CF/CM/CU24C	21	600 - 1000	800	24.0	16.8	14.25	12.25
TW4B2421S	CF/CM/CU30A	14.5	600 - 1000	800	24.0	16.8	14.50	12.25
TW4B2421S	CF/CM/CU30B	17.5	600 - 1000	800	24.0	16.8	14.50	12.25
TW4B2421S	CF/CM/CU30C	21	600 - 1000	800	24.0	16.8	14.50	12.25
TW4B2421S	CF/CM/CU30D	24.5	600 - 1000	800	24.0	16.8	14.50	12.25
TW4B2421S	CF/CM/CU36B	17.5	600 - 1000	800	24.0	16.4	14.75	12.25
TW4B2421S	CF/CM/CU36C	21	600 - 1000	800	24.0	16.4	14.75	12.25
TW4B2421S	CF/CM/CU36D	24.5	600 - 1000	800	24.0	16.4	14.75	12.25
TW4B2421S	CF/CM/CU42C	21	600 - 1000	800	24.0	16.8	14.75	12.25
TW4B2421S	CF/CM/CU42D	24.5	600 - 1000	800	24.0	16.8	14.75	12.25
TW4B2421S	CF/CM36A	14.5	600 - 1000	800	24.0	16.4	14.75	12.25
TW4B2421S	CF42B	17.5	600 - 1000	800	24.0	16.8	14.75	12.25
TW4B3021S	CF/CM/CU30B	17.5	800 - 1200	1000	28.8	20.6	14.00	12.20
TW4B3021S	CF/CM/CU30C	21	800 - 1200	1000	28.8	20.6	14.00	12.20
TW4B3021S	CF/CM/CU30D	24.5	800 - 1200	1000	28.8	20.6	14.00	12.20
TW4B3021S	CF/CM/CU36B	17.5	800 - 1200	1000	29.2	20.6	14.00	12.25
TW4B3021S	CF/CM/CU36C	21	800 - 1200	1000	29.2	20.6	14.00	12.25
TW4B3021S	CF/CM/CU36D	24.5	800 - 1200	1000	29.2	20.6	14.00	12.25

COOLING CAPACITY - Upflow, Downflow & Horizontal Furnaces and Coils (Coil Only Ratings) (Continued)

UNIT MODEL	COIL		CFM RANGE (MIN.-MAX.)	COOLING				
	MODEL	WIDTH		RATED CFM	NET MBH		SEER ¹	EER
					TOTAL	SENS.		
TW4B3021S	CF/CM/CU42C	21	800 - 1200	1000	29.2	20.6	14.00	12.25
TW4B3021S	CF/CM/CU42D	24.5	800 - 1200	1000	29.2	20.6	14.00	12.25
TW4B3021S	CF/CM36A	14.5	800 - 1200	900	28.8	19.4	14.00	12.25
TW4B3021S	CF42B	17.5	800 - 1200	1000	29.2	20.6	14.00	12.20
TW4B3621S	CF/CM/CU36B	17.5	1000 - 1400	1200	35.0	25.0	14.00	12.20
TW4B3621S	CF/CM/CU36C	21	1000 - 1400	1200	35.0	25.0	14.00	12.20
TW4B3621S	CF/CM/CU36D	24.5	1000 - 1400	1200	35.0	25.0	14.00	12.20
TW4B3621S	CF/CM/CU42C	21	1000 - 1400	1200	36.0	25.6	14.00	12.25
TW4B3621S	CF/CM/CU42D	24.5	1000 - 1400	1200	36.0	25.6	14.00	12.25
TW4B3621S	CF/CM/CU48C	21	1000 - 1400	1200	36.0	25.6	14.00	12.25
TW4B3621S	CF/CM/CU48D	24.5	1000 - 1400	1200	36.0	25.6	14.00	12.25
TW4B3621S	CF42B	17.5	1000 - 1400	1200	36.0	25.6	14.00	12.25
TW4B4221S	CF/CM/CU42C	21	1200 - 1600	1400	40.0	30.0	14.00	12.20
TW4B4221S	CF/CM/CU42D	24.5	1200 - 1600	1400	40.0	30.0	14.00	12.20
TW4B4221S	CF/CM/CU48C	21	1200 - 1600	1400	40.5	32.0	14.00	12.25
TW4B4221S	CF/CM/CU48D	24.5	1200 - 1600	1400	40.5	32.0	14.00	12.25
TW4B4221S	CF/CM/CU60C	21	1200 - 1600	1400	41.0	32.5	14.00	12.25
TW4B4221S	CF/CM/CU60D	24.5	1200 - 1600	1400	41.0	32.5	14.00	12.25
TW4B4221S	CF/CM64D	24.5	1200 - 1600	1400	41.5	32.5	14.00	12.25
TW4B4221S	CF42B	17.5	1200 - 1600	1225	38.5	29.0	14.00	12.20
TW4B4821S	CF/CM/CU48C	21	1400 - 1800	1600	47.5	34.2	14.00	11.75
TW4B4821S	CF/CM/CU48D	24.5	1400 - 1800	1600	47.5	34.2	14.00	11.75
TW4B4821S	CF/CM/CU60C	21	1400 - 1800	1600	48.0	36.0	14.50	12.25
TW4B4821S	CF/CM/CU60D	24.5	1400 - 1800	1600	48.0	36.0	14.50	12.25
TW4B4821S	CF/CM64D	24.5	1400 - 1800	1600	48.0	36.0	14.75	12.25
TW4B6021S	CF/CM/CU60C	21	1535 - 1935	1735	56.0	41.0	14.00	11.75
TW4B6021S	CF/CM/CU60D	24.5	1535 - 1935	1725	56.0	41.0	14.00	11.75
TW4B6021S	CF/CM64D	24.5	1535 - 1935	1775	57.0	42.0	14.00	11.75

For rated condition information, see the footnotes below the System Capacity - Single Piece and Modular Air Handlers table.

1. Requires a S1-2FD06700224 Blower Time Delay unless a standard furnace is equipped with one.

— = Not Applicable.

MP Modular Air Handlers use Coil Only Ratings.

PSC furnaces, such as the TG8S, TGLS, and TG9S, use Coil Only Ratings.

COOLING CAPACITY - With High Efficiency Motor Furnaces¹

UNIT MODEL	FURNACE		COIL MODEL ²	COOLING				
	MODEL	WIDTH		RATED CFM	NET MBH		SEER	EER
					TOTAL	SENS.		
TW4B1821S	TL8E060A12UH11	14.5	CF/CM/CU18A	600	18.0	14.0	16.00	13.25
TW4B1821S	TL8E060A12UH11	14.5	CF/CM/CU18B	700	18.0	14.9	16.25	13.25
TW4B1821S	TL8E060A12UH11	14.5	CF/CM/CU24A	600	18.0	14.0	16.25	13.25
TW4B1821S	TL8E060A12UH11	14.5	CF/CM/CU24B	650	18.0	14.6	16.25	13.25
TW4B1821S	TL8E060A12UH11	14.5	CF/CM/CU30A	600	18.0	13.9	16.25	13.25
TW4B1821S	TL8E060A12UH11	14.5	CF/CM/CU30B	700	18.0	14.9	16.25	13.25
TW4B1821S	TL8E060A12UH11	14.5	CF/CM/CU36B	700	18.0	14.8	16.25	13.25
TW4B1821S	TL8E060A12UH11	14.5	CF/CM36A	625	18.0	14.3	16.25	13.25
TW4B1821S	TL9E060B12UH11	17.5	CF/CM/CU18B	650	18.0	14.5	16.00	13.25
TW4B1821S	TL9E060B12UH11	17.5	CF/CM/CU24B	650	18.0	14.6	16.25	13.25
TW4B1821S	TL9E060B12UH11	17.5	CF/CM/CU30B	625	18.0	14.0	16.25	13.25
TW4B1821S	TL9E060B12UH11	17.5	CF/CM/CU36B	650	18.0	14.5	16.25	13.25
TW4B1821S	TL9E060B12UH11	17.5	CF/CM/CU36C	700	18.0	14.8	16.25	13.25

COOLING CAPACITY - With High Efficiency Motor Furnaces¹ (Continued)

UNIT MODEL	FURNACE		COIL MODEL ²	COOLING				
	MODEL	WIDTH		RATED CFM	NET MBH		SEER	EER
					TOTAL	SENS.		
TW4B1821S	TL9E060B12UH11	17.5	CF/CM24C	650	18.0	14.6	16.25	13.25
TW4B1821S	TL9E060B12UH11	17.5	CF/CM30C	700	18.0	14.9	16.25	13.25
TW4B1821S	TM8E040A12MP11	14.5	CF/CM/CU18A	725	18.0	15.4	16.00	13.00
TW4B1821S	TM8E040A12MP11	14.5	CF/CM/CU18B	675	18.0	14.8	16.00	13.25
TW4B1821S	TM8E040A12MP11	14.5	CF/CM/CU24A	650	18.0	14.6	16.25	13.25
TW4B1821S	TM8E040A12MP11	14.5	CF/CM/CU24B	700	18.0	15.0	16.25	13.25
TW4B1821S	TM8E040A12MP11	14.5	CF/CM/CU30A	625	18.0	14.0	16.25	13.25
TW4B1821S	TM8E040A12MP11	14.5	CF/CM/CU30B	675	18.0	14.7	16.25	13.25
TW4B1821S	TM8E040A12MP11	14.5	CF/CM/CU36B	700	18.0	14.8	16.25	13.25
TW4B1821S	TM8E040A12MP11	14.5	CF/CM36A	725	18.0	15.0	16.25	13.25
TW4B1821S	TM8E060A12MP11	14.5	CF/CM/CU18A	725	18.0	15.4	16.00	13.00
TW4B1821S	TM8E060A12MP11	14.5	CF/CM/CU24A	725	18.0	15.2	16.00	13.25
TW4B1821S	TM8E060A12MP11	14.5	CF/CM/CU30A	725	18.0	15.2	16.25	13.25
TW4B1821S	TM8E060A12MP11	14.5	CF/CM36A	725	18.0	15.0	16.25	13.25
TW4B1821S	TM8E080B12MP11	17.5	CF/CM/CU18B	725	18.0	15.4	16.00	13.25
TW4B1821S	TM8E080B12MP11	17.5	CF/CM/CU24B	725	18.0	15.2	16.25	13.25
TW4B1821S	TM8E080B12MP11	17.5	CF/CM/CU30B	725	18.0	15.2	16.25	13.25
TW4B1821S	TM8E080B12MP11	17.5	CF/CM/CU36B	725	18.0	15.0	16.25	13.25
TW4B1821S	TM8E100B12MP11	17.5	CF/CM/CU18B	700	18.0	14.9	16.00	13.25
TW4B1821S	TM8E100B12MP11	17.5	CF/CM/CU24B	725	18.0	15.2	16.25	13.25
TW4B1821S	TM8E100B12MP11	17.5	CF/CM/CU30B	725	18.0	15.2	16.25	13.25
TW4B1821S	TM8E100B12MP11	17.5	CF/CM/CU36B	725	18.0	15.0	16.25	13.25
TW4B1821S	TM8E100B12MP11	17.5	CF/CM/CU36C	725	18.0	15.0	16.25	13.25
TW4B1821S	TM8E100B12MP11	17.5	CF/CM24C	725	18.0	15.2	16.25	13.25
TW4B1821S	TM8E100B12MP11	17.5	CF/CM30C	725	18.0	15.2	16.25	13.25
TW4B1821S	TM8V060A12MP11C	14.5	CF/CM/CU18A	575	18.0	13.9	16.00	13.00
TW4B1821S	TM8V060A12MP11C	14.5	CF/CM/CU24A	575	18.0	13.8	16.25	13.25
TW4B1821S	TM8V060A12MP11C	14.5	CF/CM/CU30A	625	18.0	14.0	16.25	13.25
TW4B1821S	TM8V060A12MP12C	14.5	CF/CM/CU18A	575	18.0	13.9	16.00	13.00
TW4B1821S	TM8V060A12MP12C	14.5	CF/CM/CU24A	575	18.0	13.8	16.25	13.25
TW4B1821S	TM8V060A12MP12C	14.5	CF/CM/CU30A	625	18.0	14.0	16.25	13.25
TW4B1821S	TM8V060A12MP12C	14.5	CF/CM36A	625	18.0	14.3	16.25	13.25
TW4B1821S	TM8V080B12MP11C	17.5	CF/CM/CU18B	625	18.0	14.3	15.75	13.00
TW4B1821S	TM8V080B12MP11C	17.5	CF/CM/CU24B	625	18.0	14.3	16.25	13.25
TW4B1821S	TM8V080B12MP11C	17.5	CF/CM/CU30B	625	18.0	14.0	16.25	13.25
TW4B1821S	TM8V080B12MP11C	17.5	CF/CM/CU36B	625	18.0	14.3	16.25	13.25
TW4B1821S	TM8V080B12MP12C	17.5	CF/CM/CU18B	625	18.0	14.3	15.75	13.00
TW4B1821S	TM8V080B12MP12C	17.5	CF/CM/CU24B	625	18.0	14.3	16.25	13.25
TW4B1821S	TM8V080B12MP12C	17.5	CF/CM/CU30B	625	18.0	14.0	16.25	13.25
TW4B1821S	TM8V080B12MP12C	17.5	CF/CM/CU36B	625	18.0	14.3	16.25	13.25
TW4B1821S	TM8X060A12MP11	14.5	CF/CM/CU18A	600	18.0	12.0	15.50	12.75
TW4B1821S	TM8X060A12MP11	14.5	CF/CM/CU24A	600	18.0	12.1	16.00	13.00
TW4B1821S	TM8X060A12MP11	14.5	CF/CM/CU30A	625	18.0	14.0	16.25	13.25
TW4B1821S	TM8X060A12MP11	14.5	CF/CM36A	625	18.0	14.3	16.25	13.25
TW4B1821S	TM8X080B12MP11	17.5	CF/CM/CU18B	600	18.0	12.1	15.75	13.00
TW4B1821S	TM8X080B12MP11	17.5	CF/CM/CU24B	600	18.0	12.1	16.00	13.00
TW4B1821S	TM8X080B12MP11	17.5	CF/CM/CU30B	600	18.0	11.9	16.25	13.25
TW4B1821S	TM8X080B12MP11	17.5	CF/CM/CU36B	600	18.0	12.3	16.25	13.25
TW4B1821S	TM8X080C16MP11	21.0	CF/CM/CU24C	700	18.0	15.0	16.25	13.25
TW4B1821S	TM8X080C16MP11	21.0	CF/CM/CU30C	700	18.0	14.9	16.25	13.25
TW4B1821S	TM8X080C16MP11	21.0	CF/CM/CU36C	700	18.0	14.8	16.25	13.25
TW4B1821S	TM8X080C16MP11	21.0	CF/CM24C	700	18.0	15.0	16.25	13.25
TW4B1821S	TM8X080C16MP11	21.0	CF/CM30C	700	18.0	14.9	16.25	13.25

COOLING CAPACITY - With High Efficiency Motor Furnaces¹ (Continued)

UNIT MODEL	FURNACE		COIL MODEL ²	COOLING				
	MODEL	WIDTH		RATED CFM	NET MBH		SEER	EER
					TOTAL	SENS.		
TW4B1821S	TM8X080C16MP11	21.0	CF/CM36D	625	18.0	12.2	16.25	13.25
TW4B1821S	TM8X100C16MP11	21.0	CF/CM/CU24C	700	18.0	15.0	16.25	13.25
TW4B1821S	TM8X100C16MP11	21.0	CF/CM/CU30C	700	18.0	14.9	16.25	13.25
TW4B1821S	TM8X100C16MP11	21.0	CF/CM/CU36C	700	18.0	14.8	16.25	13.25
TW4B1821S	TM8X100C16MP11	21.0	CF/CM24C	700	18.0	15.0	16.25	13.25
TW4B1821S	TM8X100C16MP11	21.0	CF/CM30C	700	18.0	14.9	16.25	13.25
TW4B1821S	TM8Y060A12MP11	14.5	CF/CM/CU18A	600	18.0	12.0	15.50	12.75
TW4B1821S	TM8Y060A12MP11	14.5	CF/CM/CU24A	600	18.0	12.1	16.00	13.00
TW4B1821S	TM8Y060A12MP11	14.5	CF/CM/CU30A	625	18.0	14.0	16.25	13.25
TW4B1821S	TM8Y060A12MP11	14.5	CF/CM36A	625	18.0	14.3	16.25	13.25
TW4B1821S	TM8Y080B12MP11	17.5	CF/CM/CU18B	600	18.0	12.1	15.75	13.00
TW4B1821S	TM8Y080B12MP11	17.5	CF/CM/CU24B	600	18.0	12.1	16.00	13.00
TW4B1821S	TM8Y080B12MP11	17.5	CF/CM/CU30B	600	18.0	11.9	16.25	13.25
TW4B1821S	TM8Y080B12MP11	17.5	CF/CM/CU36B	600	18.0	12.3	16.25	13.25
TW4B1821S	TM8Y080C16MP11	21.0	CF/CM/CU24C	700	18.0	15.0	16.25	13.25
TW4B1821S	TM8Y080C16MP11	21.0	CF/CM/CU30C	700	18.0	14.9	16.25	13.25
TW4B1821S	TM8Y080C16MP11	21.0	CF/CM/CU36C	700	18.0	14.8	16.25	13.25
TW4B1821S	TM8Y080C16MP11	21.0	CF/CM24C	700	18.0	15.0	16.25	13.25
TW4B1821S	TM8Y080C16MP11	21.0	CF/CM30C	700	18.0	14.9	16.25	13.25
TW4B1821S	TM8Y080C16MP11	21.0	CF/CM36D	625	18.0	12.2	16.25	13.25
TW4B1821S	TM8Y100C16MP11	21.0	CF/CM/CU24C	700	18.0	15.0	16.25	13.25
TW4B1821S	TM8Y100C16MP11	21.0	CF/CM/CU30C	700	18.0	14.9	16.25	13.25
TW4B1821S	TM8Y100C16MP11	21.0	CF/CM/CU36C	700	18.0	14.8	16.25	13.25
TW4B1821S	TM8Y100C16MP11	21.0	CF/CM24C	700	18.0	15.0	16.25	13.25
TW4B1821S	TM8Y100C16MP11	21.0	CF/CM30C	700	18.0	14.9	16.25	13.25
TW4B1821S	TM8Y100C16MP11	21.0	CF/CM36D	625	18.0	12.2	16.25	13.25
TW4B1821S	TM9E040A10MP11	14.5	CF/CM/CU18A	600	18.0	12.1	15.75	13.00
TW4B1821S	TM9E040A10MP11	14.5	CF/CM/CU24A	500	17.7	12.8	15.25	12.75
TW4B1821S	TM9E040A10MP11	14.5	CF/CM/CU30A	500	17.8	12.9	15.50	12.75
TW4B1821S	TM9E040A10MP11	14.5	CF/CM36A	500	18.0	13.0	15.75	13.00
TW4B1821S	TM9E040A10MP12	14.5	CF/CM/CU18A	600	18.0	14.0	15.50	12.75
TW4B1821S	TM9E040A10MP12	14.5	CF/CM/CU18B	625	18.0	14.3	15.50	12.75
TW4B1821S	TM9E040A10MP12	14.5	CF/CM/CU24A	600	18.0	14.0	15.75	13.00
TW4B1821S	TM9E040A10MP12	14.5	CF/CM/CU24B	625	18.0	14.3	15.75	13.00
TW4B1821S	TM9E040A10MP12	14.5	CF/CM/CU30A	600	18.0	13.9	16.00	13.00
TW4B1821S	TM9E040A10MP12	14.5	CF/CM/CU30B	625	18.0	14.1	16.00	13.25
TW4B1821S	TM9E040A10MP12	14.5	CF/CM/CU36B	625	18.0	14.3	16.00	13.25
TW4B1821S	TM9E040A10MP12	14.5	CF/CM36A	600	18.0	14.0	16.00	13.25
TW4B1821S	TM9E060A10MP12	14.5	CF/CM/CU18A	675	18.0	14.8	15.50	12.75
TW4B1821S	TM9E060A10MP12	14.5	CF/CM/CU18B	700	18.0	14.9	15.75	13.00
TW4B1821S	TM9E060A10MP12	14.5	CF/CM/CU24A	675	18.0	14.7	15.75	13.00
TW4B1821S	TM9E060A10MP12	14.5	CF/CM/CU24B	700	18.0	15.0	15.75	13.00
TW4B1821S	TM9E060A10MP12	14.5	CF/CM/CU30A	675	18.0	14.7	16.00	13.25
TW4B1821S	TM9E060A10MP12	14.5	CF/CM/CU30B	700	18.0	14.9	16.25	13.25
TW4B1821S	TM9E060A10MP12	14.5	CF/CM/CU36B	700	18.0	14.8	16.25	13.25
TW4B1821S	TM9E060A10MP12	14.5	CF/CM36A	675	18.0	14.6	16.25	13.25
TW4B1821S	TM9E060B12MP11	17.5	CF/CM/CU18B	675	18.0	14.8	15.50	12.75
TW4B1821S	TM9E060B12MP11	17.5	CF/CM/CU24B	675	18.0	14.7	15.75	12.75
TW4B1821S	TM9E060B12MP11	17.5	CF/CM/CU30B	675	18.0	14.7	16.00	13.00
TW4B1821S	TM9E060B12MP11	17.5	CF/CM/CU36B	600	18.0	12.3	16.25	13.25
TW4B1821S	TM9E060B12MP11	17.5	CF/CM/CU36C	700	18.0	14.8	16.25	13.25
TW4B1821S	TM9E060B12MP11	17.5	CF/CM24C	675	18.0	14.7	15.75	12.75
TW4B1821S	TM9E060B12MP11	17.5	CF/CM30C	675	18.0	14.7	16.00	13.00

COOLING CAPACITY - With High Efficiency Motor Furnaces¹ (Continued)

UNIT MODEL	FURNACE		COIL MODEL ²	COOLING				
	MODEL	WIDTH		RATED CFM	NET MBH		SEER	EER
					TOTAL	SENS.		
TW4B1821S	TM9E080B12MP11	17.5	CF/CM/CU18B	600	18.0	12.1	15.50	12.75
TW4B1821S	TM9E080B12MP11	17.5	CF/CM/CU24B	700	18.0	15.0	16.00	13.00
TW4B1821S	TM9E080B12MP11	17.5	CF/CM/CU30B	600	18.0	12.0	16.00	13.00
TW4B1821S	TM9E080B12MP11	17.5	CF/CM/CU36B	700	18.0	14.8	16.25	13.25
TW4B1821S	TM9E080C16MP11	21.0	CF/CM/CU36C	600	18.0	12.3	16.25	13.25
TW4B1821S	TM9E080C16MP11	21.0	CF/CM24C	600	18.0	14.0	16.25	13.25
TW4B1821S	TM9E080C16MP11	21.0	CF/CM30C	600	18.0	13.9	16.25	13.25
TW4B1821S	TM9E080C16MP11	21.0	CF/CM36D	600	18.0	14.0	16.25	13.25
TW4B1821S	TM9E100C16MP11	21.0	CF/CM/CU24C	625	18.0	14.3	16.25	13.25
TW4B1821S	TM9E100C16MP11	21.0	CF/CM/CU30C	625	18.0	14.0	16.25	13.25
TW4B1821S	TM9E100C16MP11	21.0	CF/CM/CU30D	650	18.0	14.2	16.25	13.25
TW4B1821S	TM9E100C16MP11	21.0	CF/CM/CU36C	650	18.0	14.5	16.25	13.25
TW4B1821S	TM9E100C16MP11	21.0	CF/CM/CU36D	650	18.0	14.5	16.25	13.25
TW4B1821S	TM9E100C16MP11	21.0	CF/CM24C	625	18.0	14.3	16.25	13.25
TW4B1821S	TM9E100C16MP11	21.0	CF/CM30C	625	18.0	14.0	16.25	13.25
TW4B1821S	TM9E100C16MP11	21.0	CF/CM36D	650	18.0	14.5	16.25	13.25
TW4B1821S	TM9E100C20MP11	21.0	CF/CM/CU36C	625	18.0	12.1	15.25	12.50
TW4B1821S	TM9V040A10MP11C	14.5	CF/CM/CU18A	525	18.0	13.3	15.00	12.50
TW4B1821S	TM9V040A10MP11C	14.5	CF/CM/CU18B	525	18.0	13.3	15.25	12.50
TW4B1821S	TM9V040A10MP11C	14.5	CF/CM/CU24A	525	18.0	13.2	15.25	12.50
TW4B1821S	TM9V040A10MP11C	14.5	CF/CM/CU24B	575	18.0	13.8	15.50	12.75
TW4B1821S	TM9V040A10MP11C	14.5	CF/CM/CU30A	525	18.0	13.4	15.50	12.75
TW4B1821S	TM9V040A10MP11C	14.5	CF/CM/CU30B	625	18.0	14.1	15.75	13.00
TW4B1821S	TM9V040A10MP11C	14.5	CF/CM/CU36B	525	18.0	13.3	15.75	13.00
TW4B1821S	TM9V040A10MP11C	14.5	CF/CM36A	525	18.0	13.3	15.75	13.00
TW4B1821S	TM9V040A10MP12C	14.5	CF/CM/CU18A	525	18.0	13.3	15.00	12.50
TW4B1821S	TM9V040A10MP12C	14.5	CF/CM/CU18B	525	18.0	13.3	15.25	12.50
TW4B1821S	TM9V040A10MP12C	14.5	CF/CM/CU24A	525	18.0	13.2	15.25	12.50
TW4B1821S	TM9V040A10MP12C	14.5	CF/CM/CU24B	575	18.0	13.8	15.50	12.75
TW4B1821S	TM9V040A10MP12C	14.5	CF/CM/CU30A	525	18.0	13.4	15.50	12.75
TW4B1821S	TM9V040A10MP12C	14.5	CF/CM/CU30B	625	18.0	14.1	15.75	13.00
TW4B1821S	TM9V040A10MP12C	14.5	CF/CM/CU36B	525	18.0	13.3	15.75	13.00
TW4B1821S	TM9V040A10MP12C	14.5	CF/CM36A	525	18.0	13.3	15.75	13.00
TW4B1821S	TM9V060B12MP11C	17.5	CF/CM/CU18B	600	18.0	14.0	15.75	12.75
TW4B1821S	TM9V060B12MP11C	17.5	CF/CM/CU24B	600	18.0	14.0	16.25	13.25
TW4B1821S	TM9V060B12MP11C	17.5	CF/CM/CU30B	600	18.0	13.9	16.25	13.25
TW4B1821S	TM9V060B12MP11C	17.5	CF/CM/CU36B	600	18.0	12.3	16.25	13.25
TW4B1821S	TM9V060B12MP11C	17.5	CF/CM/CU36C	700	18.0	14.8	16.25	13.25
TW4B1821S	TM9V060B12MP11C	17.5	CF/CM24C	600	18.0	14.0	16.25	13.25
TW4B1821S	TM9V060B12MP11C	17.5	CF/CM30C	600	18.0	13.9	16.25	13.25
TW4B1821S	TM9V060B12MP12C	17.5	CF/CM/CU18B	600	18.0	14.0	15.75	12.75
TW4B1821S	TM9V060B12MP12C	17.5	CF/CM/CU24B	600	18.0	14.0	16.25	13.25
TW4B1821S	TM9V060B12MP12C	17.5	CF/CM/CU30B	600	18.0	13.9	16.25	13.25
TW4B1821S	TM9V060B12MP12C	17.5	CF/CM/CU36B	700	18.0	14.8	16.25	13.25
TW4B1821S	TM9V060B12MP12C	17.5	CF/CM/CU36C	700	18.0	14.8	16.25	13.25
TW4B1821S	TM9V060B12MP12C	17.5	CF/CM24C	600	18.0	14.0	16.25	13.25
TW4B1821S	TM9V060B12MP12C	17.5	CF/CM30C	600	18.0	13.9	16.25	13.25
TW4B1821S	TM9V080B12MP11C	17.5	CF/CM/CU18B	575	18.0	13.9	16.25	13.00
TW4B1821S	TM9V080B12MP11C	17.5	CF/CM/CU24B	575	18.0	13.8	16.25	13.25
TW4B1821S	TM9V080B12MP11C	17.5	CF/CM/CU30B	625	18.0	14.0	16.25	13.25
TW4B1821S	TM9V080B12MP11C	17.5	CF/CM/CU36B	625	18.0	14.3	16.25	13.25
TW4B1821S	TM9V080B12MP12C	17.5	CF/CM/CU18B	575	18.0	13.9	16.25	13.00
TW4B1821S	TM9V080B12MP12C	17.5	CF/CM/CU24B	575	18.0	13.8	16.25	13.25

COOLING CAPACITY - With High Efficiency Motor Furnaces¹ (Continued)

UNIT MODEL	FURNACE		COIL MODEL ²	COOLING				
	MODEL	WIDTH		RATED CFM	NET MBH		SEER	EER
					TOTAL	SENS.		
TW4B1821S	TM9V080B12MP12C	17.5	CF/CM/CU30B	625	18.0	14.0	16.25	13.25
TW4B1821S	TM9V080B12MP12C	17.5	CF/CM/CU36B	625	18.0	14.3	16.25	13.25
TW4B1821S	TM9Y040A10MP11	14.5	CF/CM/CU18A	500	17.6	12.9	15.25	12.75
TW4B1821S	TM9Y040A10MP11	14.5	CF/CM/CU24A	500	17.7	12.8	15.25	12.75
TW4B1821S	TM9Y040A10MP11	14.5	CF/CM/CU30A	500	17.8	12.9	15.50	12.75
TW4B1821S	TM9Y040A10MP11	14.5	CF/CM36A	500	18.0	13.0	15.75	13.00
TW4B1821S	TM9Y060B12MP11	17.5	CF/CM/CU18B	675	18.0	14.8	15.50	12.75
TW4B1821S	TM9Y060B12MP11	17.5	CF/CM/CU24B	675	18.0	14.7	15.75	12.75
TW4B1821S	TM9Y060B12MP11	17.5	CF/CM/CU30B	675	18.0	14.7	16.00	13.00
TW4B1821S	TM9Y060B12MP11	17.5	CF/CM/CU36B	600	18.0	12.3	16.25	13.25
TW4B1821S	TM9Y060B12MP11	17.5	CF/CM/CU36C	700	18.0	14.8	16.25	13.25
TW4B1821S	TM9Y060B12MP11	17.5	CF/CM24C	675	18.0	14.7	15.75	12.75
TW4B1821S	TM9Y060B12MP11	17.5	CF/CM30C	675	18.0	14.7	16.00	13.00
TW4B1821S	TM9Y080B12MP11	17.5	CF/CM/CU18B	700	18.0	14.9	16.00	13.00
TW4B1821S	TM9Y080B12MP11	17.5	CF/CM/CU24B	700	18.0	15.0	16.00	13.00
TW4B1821S	TM9Y080B12MP11	17.5	CF/CM/CU30B	700	18.0	14.9	16.25	13.25
TW4B1821S	TM9Y080B12MP11	17.5	CF/CM/CU36B	700	18.0	14.8	16.25	13.25
TW4B1821S	TM9Y080C16MP11	21.0	CF/CM/CU36C	600	18.0	12.3	16.25	13.25
TW4B1821S	TM9Y080C16MP11	21.0	CF/CM24C	600	18.0	14.0	16.25	13.25
TW4B1821S	TM9Y080C16MP11	21.0	CF/CM30C	600	18.0	13.9	16.25	13.25
TW4B1821S	TM9Y080C16MP11	21.0	CF/CM36D	600	18.0	14.0	16.25	13.25
TW4B1821S	TM9Y100C16MP11	21.0	CF/CM/CU24C	625	18.0	14.3	16.25	13.25
TW4B1821S	TM9Y100C16MP11	21.0	CF/CM/CU30C	625	18.0	14.0	16.25	13.25
TW4B1821S	TM9Y100C16MP11	21.0	CF/CM/CU30D	650	18.0	14.2	16.25	13.25
TW4B1821S	TM9Y100C16MP11	21.0	CF/CM/CU36C	650	18.0	14.5	16.25	13.25
TW4B1821S	TM9Y100C16MP11	21.0	CF/CM/CU36D	650	18.0	14.5	16.25	13.25
TW4B1821S	TM9Y100C16MP11	21.0	CF/CM24C	625	18.0	14.3	16.25	13.25
TW4B1821S	TM9Y100C16MP11	21.0	CF/CM30C	625	18.0	14.0	16.25	13.25
TW4B1821S	TM9Y100C16MP11	21.0	CF/CM36D	650	18.0	14.5	16.25	13.25
TW4B1821S	TM9Y100C20MP11	21.0	CF/CM/CU36C	625	18.0	12.1	15.25	12.50
TW4B1821S	TM9Y100C20MP11	21.0	CF/CM24C	625	18.0	12.3	14.75	12.25
TW4B1821S	TM9Y100C20MP11	21.0	CF/CM30C	625	18.0	12.2	15.00	12.50
TW4B1821S	TM9Y100C20MP11	21.0	CF/CM36D	650	18.0	12.5	15.25	12.50
TW4B1821S	TM9Y120D20MP11	24.5	CF/CM36D	600	18.0	12.2	15.25	12.50
TW4B1821S	TMLV060A12MP12C	14.5	CF/CM/CU18A	575	18.0	13.9	16.00	13.00
TW4B1821S	TMLV060A12MP12C	14.5	CF/CM/CU24A	575	18.0	13.8	16.25	13.25
TW4B1821S	TMLV060A12MP12C	14.5	CF/CM/CU30A	625	18.0	14.0	16.25	13.25
TW4B1821S	TMLV060A12MP12C	14.5	CF/CM36A	625	18.0	14.3	16.25	13.25
TW4B1821S	TMLV080B12MP12C	17.5	CF/CM/CU18B	625	18.0	14.3	15.75	13.00
TW4B1821S	TMLV080B12MP12C	17.5	CF/CM/CU24B	625	18.0	14.3	16.25	13.25
TW4B1821S	TMLV080B12MP12C	17.5	CF/CM/CU30B	625	18.0	14.0	16.25	13.25
TW4B1821S	TMLV080B12MP12C	17.5	CF/CM/CU36B	625	18.0	14.3	16.25	13.25
TW4B1821S	TMLX060A12MP11	14.5	CF/CM/CU18A	600	18.0	12.0	15.50	12.75
TW4B1821S	TMLX060A12MP11	14.5	CF/CM/CU24A	600	18.0	12.1	16.00	13.00
TW4B1821S	TMLX060A12MP11	14.5	CF/CM/CU30A	625	18.0	14.0	16.25	13.25
TW4B1821S	TMLX060A12MP11	14.5	CF/CM36A	625	18.0	14.3	16.25	13.25
TW4B1821S	TMLX080B12MP11	17.5	CF/CM/CU18B	600	18.0	12.1	15.75	13.00
TW4B1821S	TMLX080B12MP11	17.5	CF/CM/CU24B	600	18.0	12.1	16.00	13.00
TW4B1821S	TMLX080B12MP11	17.5	CF/CM/CU30B	600	18.0	11.9	16.25	13.25
TW4B1821S	TMLX080B12MP11	17.5	CF/CM/CU36B	600	18.0	12.3	16.25	13.25
TW4B1821S	TMLX080C16MP11	21.0	CF/CM/CU24C	700	18.0	15.0	16.25	13.25
TW4B1821S	TMLX080C16MP11	21.0	CF/CM/CU30C	700	18.0	14.9	16.25	13.25
TW4B1821S	TMLX080C16MP11	21.0	CF/CM/CU36C	700	18.0	14.8	16.25	13.25

COOLING CAPACITY - With High Efficiency Motor Furnaces¹ (Continued)

UNIT MODEL	FURNACE		COIL MODEL ²	COOLING				
	MODEL	WIDTH		RATED CFM	NET MBH		SEER	EER
					TOTAL	SENS.		
TW4B1821S	TMLX080C16MP11	21.0	CF/CM24C	700	18.0	15.0	16.25	13.25
TW4B1821S	TMLX080C16MP11	21.0	CF/CM30C	700	18.0	14.9	16.25	13.25
TW4B1821S	TMLX080C16MP11	21.0	CF/CM36D	625	18.0	12.2	16.25	13.25
TW4B1821S	TMLX100C16MP11	21.0	CF/CM/CU24C	700	18.0	15.0	16.25	13.25
TW4B1821S	TMLX100C16MP11	21.0	CF/CM/CU30C	700	18.0	14.9	16.25	13.25
TW4B1821S	TMLX100C16MP11	21.0	CF/CM/CU36C	700	18.0	14.8	16.25	13.25
TW4B1821S	TMLX100C16MP11	21.0	CF/CM24C	700	18.0	15.0	16.25	13.25
TW4B1821S	TMLX100C16MP11	21.0	CF/CM30C	700	18.0	14.9	16.25	13.25
TW4B1821S	TMLX100C16MP11	21.0	CF/CM36D	625	18.0	12.2	16.25	13.25
TW4B1821S	TP9C060B12MP12C	17.5	CF/CM/CU18B	625	18.0	12.3	15.75	12.75
TW4B1821S	TP9C060B12MP12C	17.5	CF/CM/CU24B	550	18.0	11.6	16.25	13.25
TW4B1821S	TP9C060B12MP12C	17.5	CF/CM/CU30B	650	18.0	12.4	16.25	13.25
TW4B1821S	TP9C060B12MP12C	17.5	CF/CM/CU36B	600	18.0	12.3	16.25	13.25
TW4B1821S	TP9C060B12MP13C	17.5	CF/CM/CU18B	600	18.0	14.0	15.75	12.75
TW4B1821S	TP9C060B12MP13C	17.5	CF/CM/CU24B	600	18.0	14.0	16.25	13.25
TW4B1821S	TP9C060B12MP13C	17.5	CF/CM/CU30B	600	18.0	13.9	16.25	13.25
TW4B1821S	TP9C060B12MP13C	17.5	CF/CM/CU36B	700	18.0	14.8	16.25	13.25
TW4B1821S	TP9C060B12MP13C	17.5	CF/CM/CU36C	700	18.0	14.8	16.25	13.25
TW4B1821S	TP9C060B12MP13C	17.5	CF/CM24C	600	18.0	14.0	16.25	13.25
TW4B1821S	TP9C060B12MP13C	17.5	CF/CM30C	600	18.0	13.9	16.25	13.25
TW4B1821S	TP9C080B12MP12C	17.5	CF/CM/CU18B	575	18.0	13.9	16.25	13.00
TW4B1821S	TP9C080B12MP12C	17.5	CF/CM/CU24B	575	18.0	13.8	16.25	13.25
TW4B1821S	TP9C080B12MP12C	17.5	CF/CM/CU30B	625	18.0	14.0	16.25	13.25
TW4B1821S	TP9C080B12MP12C	17.5	CF/CM/CU36B	625	18.0	14.3	16.25	13.25
TW4B1821S	TP9C080B12MP13C	17.5	CF/CM/CU18B	575	18.0	13.9	16.25	13.00
TW4B1821S	TP9C080B12MP13C	17.5	CF/CM/CU24B	575	18.0	13.8	16.25	13.25
TW4B1821S	TP9C080B12MP13C	17.5	CF/CM/CU30B	625	18.0	14.0	16.25	13.25
TW4B1821S	TP9C080B12MP13C	17.5	CF/CM/CU36B	625	18.0	14.3	16.25	13.25
TW4B1821S	TPLC060A12MP13C	14.5	CF/CM/CU18A	575	18.0	13.9	16.00	13.00
TW4B1821S	TPLC060A12MP13C	14.5	CF/CM/CU24A	575	18.0	13.8	16.25	13.25
TW4B1821S	TPLC060A12MP13C	14.5	CF/CM/CU30A	625	18.0	14.0	16.25	13.25
TW4B1821S	TPLC060A12MP13C	14.5	CF/CM36A	625	18.0	14.3	16.25	13.25
TW4B1821S	TPLC080B12MP12C	17.5	CF/CM/CU18B	625	18.0	14.3	15.75	13.00
TW4B1821S	TPLC080B12MP12C	17.5	CF/CM/CU24B	625	18.0	14.3	16.25	13.25
TW4B1821S	TPLC080B12MP12C	17.5	CF/CM/CU30B	625	18.0	14.0	16.25	13.25
TW4B1821S	TPLC080B12MP12C	17.5	CF/CM/CU36B	625	18.0	14.3	16.25	13.25
TW4B1821S	TPLC080B12MP13C	17.5	CF/CM/CU18B	625	18.0	14.3	15.75	13.00
TW4B1821S	TPLC080B12MP13C	17.5	CF/CM/CU24B	625	18.0	14.3	16.25	13.25
TW4B1821S	TPLC080B12MP13C	17.5	CF/CM/CU30B	625	18.0	14.0	16.25	13.25
TW4B1821S	TPLC080B12MP13C	17.5	CF/CM/CU36B	625	18.0	14.3	16.25	13.25
TW4B1821S	CP9C060B12MP12C	17.5	CF/CM/CU18B	625	18.0	12.3	15.75	12.75
TW4B1821S	CP9C060B12MP12C	17.5	CF/CM/CU24B	550	18.0	11.6	16.25	13.25
TW4B1821S	CP9C060B12MP12C	17.5	CF/CM/CU30B	650	18.0	12.4	16.25	13.25
TW4B1821S	CP9C060B12MP12C	17.5	CF/CM/CU36B	600	18.0	12.3	16.25	13.25
TW4B1821S	CP9C060B12MP13C	17.5	CF/CM/CU18B	600	18.0	14.0	15.75	12.75
TW4B1821S	CP9C060B12MP13C	17.5	CF/CM/CU24B	600	18.0	14.0	16.25	13.25
TW4B1821S	CP9C060B12MP13C	17.5	CF/CM/CU30B	600	18.0	13.9	16.25	13.25
TW4B1821S	CP9C060B12MP13C	17.5	CF/CM/CU36B	700	18.0	14.8	16.25	13.25
TW4B1821S	CP9C060B12MP13C	17.5	CF/CM/CU36C	700	18.0	14.8	16.25	13.25
TW4B1821S	CP9C060B12MP13C	17.5	CF/CM24C	600	18.0	14.0	16.25	13.25
TW4B1821S	CP9C060B12MP13C	17.5	CF/CM30C	600	18.0	13.9	16.25	13.25
TW4B1821S	CP9C080B12MP12C	17.5	CF/CM/CU18B	575	18.0	13.9	16.25	13.00
TW4B1821S	CP9C080B12MP12C	17.5	CF/CM/CU24B	575	18.0	13.8	16.25	13.25

COOLING CAPACITY - With High Efficiency Motor Furnaces¹ (Continued)

UNIT MODEL	FURNACE		COIL MODEL ²	COOLING				
	MODEL	WIDTH		RATED CFM	NET MBH		SEER	EER
					TOTAL	SENS.		
TW4B1821S	CP9C080B12MP12C	17.5	CF/CM/CU30B	625	18.0	14.0	16.25	13.25
TW4B1821S	CP9C080B12MP12C	17.5	CF/CM/CU36B	625	18.0	14.3	16.25	13.25
TW4B1821S	CP9C080B12MP13C	17.5	CF/CM/CU18B	575	18.0	13.9	16.25	13.00
TW4B1821S	CP9C080B12MP13C	17.5	CF/CM/CU24B	575	18.0	13.8	16.25	13.25
TW4B1821S	CP9C080B12MP13C	17.5	CF/CM/CU30B	625	18.0	14.0	16.25	13.25
TW4B1821S	CP9C080B12MP13C	17.5	CF/CM/CU36B	625	18.0	14.3	16.25	13.25
TW4B1821S	CPLC060A12MP12C	14.5	CF/CM/CU18A	575	18.0	13.9	16.00	13.00
TW4B1821S	CPLC060A12MP12C	14.5	CF/CM/CU24A	575	18.0	13.8	16.25	13.25
TW4B1821S	CPLC060A12MP12C	14.5	CF/CM/CU30A	625	18.0	14.0	16.25	13.25
TW4B1821S	CPLC060A12MP13C	14.5	CF/CM/CU18A	575	18.0	13.9	16.00	13.00
TW4B1821S	CPLC060A12MP13C	14.5	CF/CM/CU24A	575	18.0	13.8	16.25	13.25
TW4B1821S	CPLC060A12MP13C	14.5	CF/CM/CU30A	625	18.0	14.0	16.25	13.25
TW4B1821S	CPLC060A12MP13C	14.5	CF/CM36A	625	18.0	14.3	16.25	13.25
TW4B1821S	CPLC080B12MP13C	17.5	CF/CM/CU18B	625	18.0	14.3	15.75	13.00
TW4B1821S	CPLC080B12MP13C	17.5	CF/CM/CU24B	625	18.0	14.3	16.25	13.25
TW4B1821S	CPLC080B12MP13C	17.5	CF/CM/CU30B	625	18.0	14.0	16.25	13.25
TW4B1821S	CPLC080B12MP13C	17.5	CF/CM/CU36B	625	18.0	14.3	16.25	13.25
TW4B2421S	TL8E060A12UH11	14.5	CF/CM/CU24A	650	24.0	17.1	15.50	12.75
TW4B2421S	TL8E060A12UH11	14.5	CF/CM/CU24B	700	24.0	17.6	15.75	13.00
TW4B2421S	TL8E060A12UH11	14.5	CF/CM/CU30A	650	24.0	17.6	16.00	13.25
TW4B2421S	TL8E060A12UH11	14.5	CF/CM/CU30B	700	24.0	18.0	16.00	13.25
TW4B2421S	TL8E060A12UH11	14.5	CF/CM/CU36B	700	24.0	17.4	16.25	13.25
TW4B2421S	TL8E060A12UH11	14.5	CF/CM36A	650	24.0	16.9	16.00	13.25
TW4B2421S	TL8E060A12UH11	14.5	CF42B	875	24.0	19.1	16.25	13.25
TW4B2421S	TL8E080C16UH11	21	CF/CM24C	950	24.0	19.1	15.50	12.75
TW4B2421S	TL9E060B12UH11	17.5	CF/CM/CU24B	650	24.0	17.1	15.75	13.00
TW4B2421S	TL9E060B12UH11	17.5	CF/CM/CU30B	675	24.0	17.8	16.00	13.25
TW4B2421S	TL9E060B12UH11	17.5	CF/CM/CU36B	650	24.0	16.9	16.00	13.25
TW4B2421S	TL9E060B12UH11	17.5	CF/CM/CU36C	700	24.0	17.5	16.25	13.25
TW4B2421S	TL9E060B12UH11	17.5	CF/CM/CU42C	700	24.0	17.6	16.25	13.25
TW4B2421S	TL9E060B12UH11	17.5	CF/CM24C	700	24.0	17.7	15.50	12.75
TW4B2421S	TL9E060B12UH11	17.5	CF/CM30C	700	24.0	18.0	16.00	13.25
TW4B2421S	TL9E060B12UH11	17.5	CF42B	675	24.0	17.4	16.00	13.25
TW4B2421S	TL9E080C16UH11	21	CF/CM/CU36C	925	24.0	19.7	16.25	13.25
TW4B2421S	TL9E080C16UH11	21	CF/CM/CU42C	925	24.0	19.8	16.25	13.25
TW4B2421S	TL9E080C16UH11	21	CF/CM24C	900	24.0	18.6	15.50	12.75
TW4B2421S	TL9E080C16UH11	21	CF/CM30C	925	24.0	19.8	16.25	13.25
TW4B2421S	TL9E080C16UH11	21	CF/CM36D	925	24.0	19.7	16.25	13.25
TW4B2421S	TL9E080C16UH11	21	CF/CM42D	925	24.0	19.8	16.25	13.25
TW4B2421S	TM8E040A12MP11	14.5	CF/CM/CU24A	650	24.0	17.1	15.75	13.00
TW4B2421S	TM8E040A12MP11	14.5	CF/CM/CU24B	775	24.0	18.3	15.75	13.00
TW4B2421S	TM8E040A12MP11	14.5	CF/CM/CU30A	825	24.0	18.6	15.75	13.00
TW4B2421S	TM8E040A12MP11	14.5	CF/CM/CU30B	775	24.0	18.3	16.00	13.25
TW4B2421S	TM8E040A12MP11	14.5	CF/CM/CU36B	775	24.0	18.2	16.25	13.25
TW4B2421S	TM8E040A12MP11	14.5	CF/CM36A	725	24.0	17.8	16.25	13.25
TW4B2421S	TM8E040A12MP11	14.5	CF42B	775	24.0	18.2	16.25	13.25
TW4B2421S	TM8E060A12MP11	14.5	CF/CM/CU24A	725	24.0	17.8	15.75	13.00
TW4B2421S	TM8E060A12MP11	14.5	CF/CM/CU24B	750	24.0	18.0	15.75	13.00
TW4B2421S	TM8E060A12MP11	14.5	CF/CM/CU30A	775	24.0	18.3	15.75	13.00
TW4B2421S	TM8E060A12MP11	14.5	CF/CM/CU30B	825	24.0	18.6	16.25	13.25
TW4B2421S	TM8E060A12MP11	14.5	CF/CM/CU36B	825	24.0	18.7	16.25	13.25
TW4B2421S	TM8E060A12MP11	14.5	CF/CM36A	725	24.0	17.8	16.25	13.25
TW4B2421S	TM8E060A12MP11	14.5	CF42B	825	24.0	19.0	16.25	13.25

COOLING CAPACITY - With High Efficiency Motor Furnaces¹ (Continued)

UNIT MODEL	FURNACE		COIL MODEL ²	COOLING				
	MODEL	WIDTH		RATED CFM	NET MBH		SEER	EER
					TOTAL	SENS.		
TW4B2421S	TM8E080B12MP11	17.5	CF/CM/CU24B	725	24.0	17.8	15.75	13.00
TW4B2421S	TM8E080B12MP11	17.5	CF/CM/CU30B	725	24.0	17.9	16.00	13.25
TW4B2421S	TM8E080B12MP11	17.5	CF/CM/CU36B	725	24.0	17.8	16.25	13.25
TW4B2421S	TM8E080B12MP11	17.5	CF/CM/CU36C	750	24.0	18.0	16.25	13.25
TW4B2421S	TM8E080B12MP11	17.5	CF/CM/CU42C	750	24.0	18.0	16.25	13.25
TW4B2421S	TM8E080B12MP11	17.5	CF/CM24C	750	24.0	18.0	15.75	13.00
TW4B2421S	TM8E080B12MP11	17.5	CF/CM30C	750	24.0	18.2	16.00	13.25
TW4B2421S	TM8E080B12MP11	17.5	CF42B	725	24.0	18.0	16.25	13.25
TW4B2421S	TM8E080C16MP11	21	CF/CM/CU36C	825	24.0	18.7	16.25	13.25
TW4B2421S	TM8E080C16MP11	21	CF/CM/CU42C	825	24.0	19.0	16.25	13.25
TW4B2421S	TM8E080C16MP11	21	CF/CM24C	825	24.0	18.9	16.00	13.25
TW4B2421S	TM8E080C16MP11	21	CF/CM30C	825	24.0	18.7	16.25	13.25
TW4B2421S	TM8E080C16MP11	21	CF/CM36D	825	24.0	18.7	16.25	13.25
TW4B2421S	TM8E080C16MP11	21	CF/CM42D	825	24.0	19.0	16.25	13.25
TW4B2421S	TM8E100B12MP11	17.5	CF/CM/CU24B	725	24.0	17.8	16.00	13.00
TW4B2421S	TM8E100B12MP11	17.5	CF/CM/CU30B	725	24.0	17.9	16.00	13.25
TW4B2421S	TM8E100B12MP11	17.5	CF/CM/CU36B	725	24.0	17.8	16.25	13.25
TW4B2421S	TM8E100B12MP11	17.5	CF/CM/CU36C	850	24.0	18.9	16.25	13.25
TW4B2421S	TM8E100B12MP11	17.5	CF/CM/CU42C	850	24.0	19.0	16.25	13.25
TW4B2421S	TM8E100B12MP11	17.5	CF/CM24C	725	24.0	17.8	15.75	13.00
TW4B2421S	TM8E100B12MP11	17.5	CF/CM30C	850	24.0	19.1	16.00	13.25
TW4B2421S	TM8E100B12MP11	17.5	CF42B	825	24.0	19.0	16.25	13.25
TW4B2421S	TM8E100C16MP11	21	CF/CM/CU36C	800	24.0	18.5	16.25	13.25
TW4B2421S	TM8E100C16MP11	21	CF/CM/CU42C	800	24.0	18.6	16.25	13.25
TW4B2421S	TM8E100C16MP11	21	CF/CM24C	800	24.0	18.6	16.00	13.25
TW4B2421S	TM8E100C16MP11	21	CF/CM30C	950	24.0	20.0	16.25	13.25
TW4B2421S	TM8E100C16MP11	21	CF/CM36D	800	24.0	18.5	16.25	13.25
TW4B2421S	TM8E100C16MP11	21	CF/CM42D	800	24.0	18.6	16.25	13.25
TW4B2421S	TM8E120C16MP11	21	CF/CM/CU36C	825	24.0	18.7	16.25	13.25
TW4B2421S	TM8E120C16MP11	21	CF/CM/CU42C	825	24.0	19.0	16.25	13.25
TW4B2421S	TM8E120C16MP11	21	CF/CM24C	800	24.0	18.6	16.00	13.25
TW4B2421S	TM8E120C16MP11	21	CF/CM30C	800	24.0	18.6	16.25	13.25
TW4B2421S	TM8E120C16MP11	21	CF/CM36D	825	24.0	18.7	16.25	13.25
TW4B2421S	TM8E120C16MP11	21	CF/CM42D	825	24.0	19.0	16.25	13.25
TW4B2421S	TM8V060A12MP12C	14.5	CF/CM/CU24A	800	24.0	18.5	15.25	12.50
TW4B2421S	TM8V060A12MP12C	14.5	CF/CM/CU30A	800	24.0	18.6	15.75	12.75
TW4B2421S	TM8V060A12MP12C	14.5	CF/CM36A	800	24.0	18.5	16.25	13.25
TW4B2421S	TM8V080B12MP12C	17.5	CF/CM/CU24B	825	24.0	18.8	15.50	12.75
TW4B2421S	TM8V080B12MP12C	17.5	CF/CM/CU30B	825	24.0	18.7	16.00	13.00
TW4B2421S	TM8V080B12MP12C	17.5	CF/CM/CU36B	825	24.0	18.6	16.00	13.00
TW4B2421S	TM8V080B12MP12C	17.5	CF42B	825	24.0	19.0	16.25	13.25
TW4B2421S	TM8V080C16MP12C	21	CF/CM/CU30C	875	24.0	19.3	16.25	13.25
TW4B2421S	TM8V080C16MP12C	21	CF/CM/CU30D	875	24.0	19.3	16.25	13.25
TW4B2421S	TM8V080C16MP12C	21	CF/CM/CU36C	875	24.0	19.2	16.25	13.25
TW4B2421S	TM8V080C16MP12C	21	CF/CM/CU36D	875	24.0	19.2	16.25	13.25
TW4B2421S	TM8V080C16MP12C	21	CF/CM/CU42C	875	24.0	19.2	16.25	13.25
TW4B2421S	TM8V080C16MP12C	21	CF/CM/CU42D	875	24.0	19.2	16.25	13.25
TW4B2421S	TM8V100C16MP12C	21	CF/CM/CU30C	875	24.0	19.3	16.25	13.25
TW4B2421S	TM8V100C16MP12C	21	CF/CM/CU30D	875	24.0	19.3	16.25	13.25
TW4B2421S	TM8V100C16MP12C	21	CF/CM/CU36C	875	24.0	19.2	16.25	13.25
TW4B2421S	TM8V100C16MP12C	21	CF/CM/CU36D	875	24.0	19.2	16.25	13.25
TW4B2421S	TM8V100C16MP12C	21	CF/CM/CU42C	875	24.0	19.2	16.25	13.25
TW4B2421S	TM8V100C16MP12C	21	CF/CM/CU42D	875	24.0	19.2	16.25	13.25

COOLING CAPACITY - With High Efficiency Motor Furnaces¹ (Continued)

UNIT MODEL	FURNACE		COIL MODEL ²	COOLING				
	MODEL	WIDTH		RATED CFM	NET MBH		SEER	EER
					TOTAL	SENS.		
TW4B2421S	TM8X060A12MP11	14.5	CF/CM/CU24A	750	24.0	18.1	15.50	13.00
TW4B2421S	TM8X060A12MP11	14.5	CF/CM/CU30A	750	24.0	18.2	15.75	13.25
TW4B2421S	TM8X060A12MP11	14.5	CF/CM36A	775	24.0	18.2	16.25	13.25
TW4B2421S	TM8X080B12MP11	17.5	CF/CM/CU24B	775	24.0	18.3	16.00	13.00
TW4B2421S	TM8X080B12MP11	17.5	CF/CM/CU30B	825	24.0	18.6	16.25	13.25
TW4B2421S	TM8X080B12MP11	17.5	CF/CM/CU36B	775	24.0	18.2	16.25	13.25
TW4B2421S	TM8X080B12MP11	17.5	CF42B	825	24.0	19.0	16.25	13.25
TW4B2421S	TM8X080C16MP11	21	CF/CM/CU24C	700	24.0	17.6	16.00	13.25
TW4B2421S	TM8X080C16MP11	21	CF/CM/CU30C	700	24.0	18.0	16.25	13.25
TW4B2421S	TM8X080C16MP11	21	CF/CM/CU30D	725	24.0	17.9	16.25	13.25
TW4B2421S	TM8X080C16MP11	21	CF/CM/CU36C	700	24.0	17.4	16.25	13.25
TW4B2421S	TM8X080C16MP11	21	CF/CM/CU36D	725	24.0	17.7	16.25	13.25
TW4B2421S	TM8X080C16MP11	21	CF/CM/CU42C	700	24.0	17.6	16.25	13.25
TW4B2421S	TM8X080C16MP11	21	CF/CM/CU42D	725	24.0	17.9	16.25	13.25
TW4B2421S	TM8X100C16MP11	21	CF/CM/CU24C	700	24.0	17.6	16.00	13.25
TW4B2421S	TM8X100C16MP11	21	CF/CM/CU30C	700	24.0	18.0	16.25	13.25
TW4B2421S	TM8X100C16MP11	21	CF/CM/CU30D	725	24.0	17.9	16.25	13.25
TW4B2421S	TM8X100C16MP11	21	CF/CM/CU36C	700	24.0	17.4	16.25	13.25
TW4B2421S	TM8X100C16MP11	21	CF/CM/CU36D	725	24.0	17.7	16.25	13.25
TW4B2421S	TM8X100C16MP11	21	CF/CM/CU42C	700	24.0	17.6	16.25	13.25
TW4B2421S	TM8X100C16MP11	21	CF/CM/CU42D	725	24.0	17.9	16.25	13.25
TW4B2421S	TM8Y060A12MP11	14.5	CF/CM/CU24A	750	24.0	18.1	15.50	13.00
TW4B2421S	TM8Y060A12MP11	14.5	CF/CM/CU30A	750	24.0	18.2	15.75	13.25
TW4B2421S	TM8Y060A12MP11	14.5	CF/CM36A	775	24.0	18.2	16.25	13.25
TW4B2421S	TM8Y080B12MP11	17.5	CF/CM/CU24B	775	24.0	18.3	16.00	13.00
TW4B2421S	TM8Y080B12MP11	17.5	CF/CM/CU30B	825	24.0	18.6	16.25	13.25
TW4B2421S	TM8Y080B12MP11	17.5	CF/CM/CU36B	775	24.0	18.2	16.25	13.25
TW4B2421S	TM8Y080B12MP11	17.5	CF42B	825	24.0	19.0	16.25	13.25
TW4B2421S	TM8Y080C16MP11	21	CF/CM/CU24C	700	24.0	17.6	16.00	13.25
TW4B2421S	TM8Y080C16MP11	21	CF/CM/CU30C	700	24.0	18.0	16.25	13.25
TW4B2421S	TM8Y080C16MP11	21	CF/CM/CU30D	725	24.0	17.9	16.25	13.25
TW4B2421S	TM8Y080C16MP11	21	CF/CM/CU36C	700	24.0	17.4	16.25	13.25
TW4B2421S	TM8Y080C16MP11	21	CF/CM/CU36D	725	24.0	17.7	16.25	13.25
TW4B2421S	TM8Y080C16MP11	21	CF/CM/CU42C	700	24.0	17.6	16.25	13.25
TW4B2421S	TM8Y080C16MP11	21	CF/CM/CU42D	725	24.0	17.9	16.25	13.25
TW4B2421S	TM8Y100C16MP11	21	CF/CM/CU24C	700	24.0	17.6	16.00	13.25
TW4B2421S	TM8Y100C16MP11	21	CF/CM/CU30C	700	24.0	18.0	16.25	13.25
TW4B2421S	TM8Y100C16MP11	21	CF/CM/CU30D	725	24.0	17.9	16.25	13.25
TW4B2421S	TM8Y100C16MP11	21	CF/CM/CU36C	700	24.0	17.4	16.25	13.25
TW4B2421S	TM8Y100C16MP11	21	CF/CM/CU36D	725	24.0	17.7	16.25	13.25
TW4B2421S	TM8Y100C16MP11	21	CF/CM/CU42C	700	24.0	17.6	16.25	13.25
TW4B2421S	TM8Y100C16MP11	21	CF/CM/CU42D	725	24.0	17.9	16.25	13.25
TW4B2421S	TM9E040A10MP11	14.5	CF/CM/CU24A	775	24.0	18.3	14.75	12.50
TW4B2421S	TM9E040A10MP11	14.5	CF/CM/CU30A	675	23.8	17.6	15.00	12.50
TW4B2421S	TM9E040A10MP11	14.5	CF/CM36A	775	24.0	18.2	15.25	12.75
TW4B2421S	TM9E040A10MP12	14.5	CF/CM/CU24A	650	24.0	17.2	15.00	12.50
TW4B2421S	TM9E040A10MP12	14.5	CF/CM/CU24B	675	24.0	17.3	15.00	12.50
TW4B2421S	TM9E040A10MP12	14.5	CF/CM/CU30A	650	24.0	17.6	15.50	12.75
TW4B2421S	TM9E040A10MP12	14.5	CF/CM/CU30B	675	24.0	17.8	15.50	12.75
TW4B2421S	TM9E040A10MP12	14.5	CF/CM/CU36B	675	24.0	17.3	15.75	13.00
TW4B2421S	TM9E040A10MP12	14.5	CF/CM36A	675	24.0	17.3	15.75	13.00
TW4B2421S	TM9E040A10MP12	14.5	CF42B	675	24.0	17.4	15.50	12.75
TW4B2421S	TM9E060A10MP12	14.5	CF/CM/CU24A	675	24.0	17.3	15.25	12.75

COOLING CAPACITY - With High Efficiency Motor Furnaces¹ (Continued)

UNIT MODEL	FURNACE		COIL MODEL ²	COOLING				
	MODEL	WIDTH		RATED CFM	NET MBH		SEER	EER
					TOTAL	SENS.		
TW4B2421S	TM9E060A10MP12	14.5	CF/CM/CU24B	700	24.0	17.6	15.50	12.75
TW4B2421S	TM9E060A10MP12	14.5	CF/CM/CU30A	675	24.0	17.8	15.75	13.00
TW4B2421S	TM9E060A10MP12	14.5	CF/CM/CU30B	700	24.0	18.0	15.75	13.00
TW4B2421S	TM9E060A10MP12	14.5	CF/CM/CU36B	700	24.0	17.5	16.00	13.25
TW4B2421S	TM9E060A10MP12	14.5	CF/CM36A	675	24.0	17.2	16.00	13.25
TW4B2421S	TM9E060A10MP12	14.5	CF42B	700	24.0	17.6	16.00	13.25
TW4B2421S	TM9E060B12MP11	17.5	CF/CM/CU24B	675	24.0	17.3	15.75	13.00
TW4B2421S	TM9E060B12MP11	17.5	CF/CM/CU30B	675	24.0	17.8	16.25	13.25
TW4B2421S	TM9E060B12MP11	17.5	CF/CM/CU36B	675	24.0	17.2	16.25	13.25
TW4B2421S	TM9E060B12MP11	17.5	CF/CM/CU36C	700	24.0	17.5	16.25	13.25
TW4B2421S	TM9E060B12MP11	17.5	CF/CM/CU42C	700	24.0	17.6	16.25	13.25
TW4B2421S	TM9E060B12MP11	17.5	CF/CM24C	675	24.0	17.3	15.75	13.00
TW4B2421S	TM9E060B12MP11	17.5	CF/CM30C	675	24.0	17.8	16.25	13.25
TW4B2421S	TM9E060B12MP11	17.5	CF42B	675	24.0	17.3	16.25	13.25
TW4B2421S	TM9E060B12MP12	17.5	CF/CM/CU24B	750	24.0	18.0	15.50	12.75
TW4B2421S	TM9E060B12MP12	17.5	CF/CM/CU30B	750	24.0	18.2	16.00	13.25
TW4B2421S	TM9E060B12MP12	17.5	CF/CM/CU36B	750	24.0	18.0	16.25	13.25
TW4B2421S	TM9E060B12MP12	17.5	CF/CM/CU36C	750	24.0	18.0	16.00	13.25
TW4B2421S	TM9E060B12MP12	17.5	CF/CM/CU42C	750	24.0	18.0	16.25	13.25
TW4B2421S	TM9E060B12MP12	17.5	CF/CM24C	750	24.0	18.0	15.50	12.75
TW4B2421S	TM9E060B12MP12	17.5	CF/CM30C	750	24.0	18.2	15.75	13.00
TW4B2421S	TM9E060B12MP12	17.5	CF42B	725	24.0	17.9	16.00	13.25
TW4B2421S	TM9E080B12MP11	17.5	CF/CM/CU24B	700	24.0	17.6	15.75	13.00
TW4B2421S	TM9E080B12MP11	17.5	CF/CM/CU30B	700	24.0	18.0	16.25	13.25
TW4B2421S	TM9E080B12MP11	17.5	CF/CM/CU36B	700	24.0	17.4	16.25	13.25
TW4B2421S	TM9E080B12MP11	17.5	CF42B	875	24.0	19.1	16.25	13.25
TW4B2421S	TM9E080B12MP12	17.5	CF/CM/CU24B	800	24.0	18.5	15.75	13.00
TW4B2421S	TM9E080B12MP12	17.5	CF/CM/CU30B	800	24.0	18.6	16.00	13.25
TW4B2421S	TM9E080B12MP12	17.5	CF/CM/CU36B	800	24.0	18.5	16.25	13.25
TW4B2421S	TM9E080B12MP12	17.5	CF/CM/CU36C	825	24.0	18.7	16.25	13.25
TW4B2421S	TM9E080B12MP12	17.5	CF/CM/CU42C	825	24.0	19.0	16.25	13.25
TW4B2421S	TM9E080B12MP12	17.5	CF/CM24C	800	24.0	18.5	15.75	13.00
TW4B2421S	TM9E080B12MP12	17.5	CF/CM30C	825	24.0	18.7	16.25	13.25
TW4B2421S	TM9E080B12MP12	17.5	CF42B	775	24.0	18.2	16.25	13.25
TW4B2421S	TM9E080C16MP11	21	CF/CM/CU36C	600	24.0	16.5	16.25	13.25
TW4B2421S	TM9E080C16MP11	21	CF/CM/CU42C	600	24.0	16.7	16.25	13.25
TW4B2421S	TM9E080C16MP11	21	CF/CM24C	600	24.0	16.6	16.00	13.25
TW4B2421S	TM9E080C16MP11	21	CF/CM30C	600	24.0	16.8	16.25	13.25
TW4B2421S	TM9E080C16MP11	21	CF/CM36D	600	24.0	16.5	16.25	13.25
TW4B2421S	TM9E080C16MP11	21	CF/CM42D	600	24.0	16.7	16.25	13.25
TW4B2421S	TM9E080C16MP12	21	CF/CM/CU36C	750	24.0	18.0	16.25	13.25
TW4B2421S	TM9E080C16MP12	21	CF/CM/CU42C	750	24.0	18.1	16.25	13.25
TW4B2421S	TM9E080C16MP12	21	CF/CM24C	750	24.0	18.0	16.00	13.25
TW4B2421S	TM9E080C16MP12	21	CF/CM30C	900	24.0	19.5	16.25	13.25
TW4B2421S	TM9E080C16MP12	21	CF/CM36D	750	24.0	18.0	16.25	13.25
TW4B2421S	TM9E080C16MP12	21	CF/CM42D	925	24.0	19.8	16.25	13.25
TW4B2421S	TM9E100C16MP11	21	CF/CM/CU30D	650	23.8	17.4	16.25	13.25
TW4B2421S	TM9E100C16MP11	21	CF/CM/CU36C	650	24.0	17.0	16.25	13.25
TW4B2421S	TM9E100C16MP11	21	CF/CM/CU36D	650	24.0	17.0	16.25	13.25
TW4B2421S	TM9E100C16MP11	21	CF/CM/CU42C	650	24.0	17.1	16.25	13.25
TW4B2421S	TM9E100C16MP11	21	CF/CM/CU42D	650	24.0	17.1	16.25	13.25
TW4B2421S	TM9E100C16MP12	21	CF/CM/CU36C	800	24.0	18.5	16.25	13.25
TW4B2421S	TM9E100C16MP12	21	CF/CM/CU42C	800	24.0	18.6	16.25	13.25

COOLING CAPACITY - With High Efficiency Motor Furnaces¹ (Continued)

UNIT MODEL	FURNACE		COIL MODEL ²	COOLING				
	MODEL	WIDTH		RATED CFM	NET MBH		SEER	EER
					TOTAL	SENS.		
TW4B2421S	TM9E100C16MP12	21	CF/CM24C	775	24.0	18.3	16.00	13.25
TW4B2421S	TM9E100C16MP12	21	CF/CM30C	800	24.0	18.6	16.25	13.25
TW4B2421S	TM9E100C16MP12	21	CF/CM36D	800	24.0	18.5	16.25	13.25
TW4B2421S	TM9E100C16MP12	21	CF/CM42D	800	24.0	18.6	16.25	13.25
TW4B2421S	TM9V040A10MP11C	14.5	CF/CM/CU24A	625	24.0	16.9	15.25	12.75
TW4B2421S	TM9V040A10MP11C	14.5	CF/CM/CU24B	625	24.0	16.8	15.50	12.75
TW4B2421S	TM9V040A10MP11C	14.5	CF/CM/CU30A	625	24.0	16.9	15.50	13.00
TW4B2421S	TM9V040A10MP11C	14.5	CF/CM/CU30B	625	24.0	16.9	15.75	13.00
TW4B2421S	TM9V040A10MP11C	14.5	CF/CM/CU36B	725	24.0	17.7	16.00	13.25
TW4B2421S	TM9V040A10MP11C	14.5	CF/CM36A	625	24.0	16.8	15.75	13.00
TW4B2421S	TM9V040A10MP11C	14.5	CF42B	725	24.0	17.9	15.75	13.25
TW4B2421S	TM9V040A10MP12C	14.5	CF/CM/CU24A	625	24.0	16.9	15.25	12.75
TW4B2421S	TM9V040A10MP12C	14.5	CF/CM/CU24B	625	24.0	16.8	15.50	12.75
TW4B2421S	TM9V040A10MP12C	14.5	CF/CM/CU30A	625	24.0	16.9	15.50	13.00
TW4B2421S	TM9V040A10MP12C	14.5	CF/CM/CU30B	625	24.0	16.9	15.75	13.00
TW4B2421S	TM9V040A10MP12C	14.5	CF/CM/CU36B	725	24.0	17.7	16.00	13.25
TW4B2421S	TM9V040A10MP12C	14.5	CF/CM36A	625	24.0	16.8	15.75	13.00
TW4B2421S	TM9V040A10MP12C	14.5	CF42B	725	24.0	17.9	15.75	13.25
TW4B2421S	TM9V060B12MP11C	17.5	CF/CM/CU24B	600	24.0	16.6	15.75	13.00
TW4B2421S	TM9V060B12MP11C	17.5	CF/CM/CU30B	700	24.0	18.0	16.00	13.25
TW4B2421S	TM9V060B12MP11C	17.5	CF/CM/CU36B	700	24.0	17.5	16.25	13.50
TW4B2421S	TM9V060B12MP11C	17.5	CF/CM/CU36C	700	24.0	17.5	16.25	13.50
TW4B2421S	TM9V060B12MP11C	17.5	CF/CM/CU42C	700	24.0	17.6	16.25	13.50
TW4B2421S	TM9V060B12MP11C	17.5	CF/CM24C	700	24.0	17.7	15.75	13.25
TW4B2421S	TM9V060B12MP11C	17.5	CF/CM30C	700	24.0	18.0	16.25	13.50
TW4B2421S	TM9V060B12MP11C	17.5	CF42B	700	24.0	17.6	16.25	13.50
TW4B2421S	TM9V060B12MP12C	17.5	CF/CM/CU24B	600	24.0	16.6	15.75	13.00
TW4B2421S	TM9V060B12MP12C	17.5	CF/CM/CU30B	700	24.0	18.0	16.00	13.25
TW4B2421S	TM9V060B12MP12C	17.5	CF/CM/CU36B	700	24.0	17.5	16.25	13.50
TW4B2421S	TM9V060B12MP12C	17.5	CF/CM/CU36C	700	24.0	17.5	16.25	13.50
TW4B2421S	TM9V060B12MP12C	17.5	CF/CM/CU42C	700	24.0	17.6	16.25	13.50
TW4B2421S	TM9V060B12MP12C	17.5	CF/CM24C	700	24.0	17.7	15.75	13.25
TW4B2421S	TM9V060B12MP12C	17.5	CF/CM30C	700	24.0	18.0	16.25	13.50
TW4B2421S	TM9V060B12MP12C	17.5	CF42B	700	24.0	17.6	16.25	13.50
TW4B2421S	TM9V080B12MP12C	17.5	CF/CM/CU24B	800	24.0	18.5	16.00	13.25
TW4B2421S	TM9V080B12MP12C	17.5	CF/CM/CU30B	800	24.0	18.6	16.00	13.25
TW4B2421S	TM9V080B12MP12C	17.5	CF/CM/CU36B	800	24.0	18.5	16.25	13.25
TW4B2421S	TM9V080B12MP12C	17.5	CF42B	800	24.0	18.6	16.25	13.25
TW4B2421S	TM9V080C16MP11C	21	CF/CM/CU36C	950	24.0	20.0	16.25	13.25
TW4B2421S	TM9V080C16MP11C	21	CF/CM/CU42C	950	24.0	19.7	16.25	13.25
TW4B2421S	TM9V080C16MP11C	21	CF/CM24C	950	24.0	19.1	15.25	12.50
TW4B2421S	TM9V080C16MP11C	21	CF/CM30C	950	24.0	19.9	16.25	13.25
TW4B2421S	TM9V080C16MP11C	21	CF/CM36D	950	24.0	20.0	16.25	13.25
TW4B2421S	TM9V080C16MP11C	21	CF/CM42D	950	24.0	19.7	16.25	13.25
TW4B2421S	TM9V080C16MP12C	21	CF/CM/CU36C	950	24.0	20.0	16.25	13.25
TW4B2421S	TM9V080C16MP12C	21	CF/CM/CU42C	950	24.0	19.7	16.25	13.25
TW4B2421S	TM9V080C16MP12C	21	CF/CM24C	950	24.0	19.1	15.25	12.50
TW4B2421S	TM9V080C16MP12C	21	CF/CM30C	950	24.0	19.9	16.25	13.25
TW4B2421S	TM9V080C16MP12C	21	CF/CM36D	950	24.0	20.0	16.25	13.25
TW4B2421S	TM9V080C16MP12C	21	CF/CM42D	950	24.0	19.7	16.25	13.25
TW4B2421S	TM9Y040A10MP11	14.5	CF/CM/CU24A	775	24.0	18.3	14.75	12.50
TW4B2421S	TM9Y040A10MP11	14.5	CF/CM/CU30A	675	23.8	17.6	15.00	12.50
TW4B2421S	TM9Y040A10MP11	14.5	CF/CM36A	775	24.0	18.2	15.25	12.75

COOLING CAPACITY - With High Efficiency Motor Furnaces¹ (Continued)

UNIT MODEL	FURNACE		COIL MODEL ²	COOLING				
	MODEL	WIDTH		RATED CFM	NET MBH		SEER	EER
					TOTAL	SENS.		
TW4B2421S	TM9Y060B12MP11	17.5	CF/CM/CU24B	675	24.0	17.3	15.75	13.00
TW4B2421S	TM9Y060B12MP11	17.5	CF/CM/CU30B	675	24.0	17.8	16.25	13.25
TW4B2421S	TM9Y060B12MP11	17.5	CF/CM/CU36B	675	24.0	17.2	16.25	13.25
TW4B2421S	TM9Y060B12MP11	17.5	CF/CM/CU36C	700	24.0	17.5	16.25	13.25
TW4B2421S	TM9Y060B12MP11	17.5	CF/CM/CU42C	700	24.0	17.6	16.25	13.25
TW4B2421S	TM9Y060B12MP11	17.5	CF/CM24C	675	24.0	17.3	15.75	13.00
TW4B2421S	TM9Y060B12MP11	17.5	CF/CM30C	675	24.0	17.8	16.25	13.25
TW4B2421S	TM9Y060B12MP11	17.5	CF42B	675	24.0	17.3	16.25	13.25
TW4B2421S	TM9Y080B12MP11	17.5	CF/CM/CU24B	700	24.0	17.6	15.75	13.00
TW4B2421S	TM9Y080B12MP11	17.5	CF/CM/CU30B	700	24.0	18.0	16.25	13.25
TW4B2421S	TM9Y080B12MP11	17.5	CF/CM/CU36B	700	24.0	17.4	16.25	13.25
TW4B2421S	TM9Y080B12MP11	17.5	CF42B	875	24.0	19.1	16.25	13.25
TW4B2421S	TM9Y080C16MP11	21	CF/CM/CU36C	600	24.0	16.5	16.25	13.25
TW4B2421S	TM9Y080C16MP11	21	CF/CM/CU42C	600	24.0	16.7	16.25	13.25
TW4B2421S	TM9Y080C16MP11	21	CF/CM24C	600	24.0	16.6	16.00	13.25
TW4B2421S	TM9Y080C16MP11	21	CF/CM30C	600	24.0	16.8	16.25	13.25
TW4B2421S	TM9Y080C16MP11	21	CF/CM36D	600	24.0	16.5	16.25	13.25
TW4B2421S	TM9Y080C16MP11	21	CF/CM42D	600	24.0	16.7	16.25	13.25
TW4B2421S	TM9Y100C16MP11	21	CF/CM/CU30D	650	23.8	17.4	16.25	13.25
TW4B2421S	TM9Y100C16MP11	21	CF/CM/CU36C	650	24.0	17.0	16.25	13.25
TW4B2421S	TM9Y100C16MP11	21	CF/CM/CU36D	650	24.0	17.0	16.25	13.25
TW4B2421S	TM9Y100C16MP11	21	CF/CM/CU42C	650	24.0	17.1	16.25	13.25
TW4B2421S	TM9Y100C16MP11	21	CF/CM/CU42D	650	24.0	17.1	16.25	13.25
TW4B2421S	TMLV060A12MP12C	14.5	CF/CM/CU24A	800	24.0	18.5	15.25	12.50
TW4B2421S	TMLV060A12MP12C	14.5	CF/CM/CU30A	800	24.0	18.6	15.75	12.75
TW4B2421S	TMLV060A12MP12C	14.5	CF/CM36A	800	24.0	18.5	16.25	13.25
TW4B2421S	TMLV080B12MP12C	17.5	CF/CM/CU24B	825	24.0	18.8	15.50	12.75
TW4B2421S	TMLV080B12MP12C	17.5	CF/CM/CU30B	825	24.0	18.7	16.00	13.00
TW4B2421S	TMLV080B12MP12C	17.5	CF/CM/CU36B	825	24.0	18.6	16.00	13.00
TW4B2421S	TMLV080B12MP12C	17.5	CF42B	825	24.0	19.0	16.25	13.25
TW4B2421S	TMLV080C16MP12C	21	CF/CM/CU30C	875	24.0	19.3	16.25	13.25
TW4B2421S	TMLV080C16MP12C	21	CF/CM/CU30D	875	24.0	19.3	16.25	13.25
TW4B2421S	TMLV080C16MP12C	21	CF/CM/CU36C	875	24.0	19.2	16.25	13.25
TW4B2421S	TMLV080C16MP12C	21	CF/CM/CU36D	875	24.0	19.2	16.25	13.25
TW4B2421S	TMLV080C16MP12C	21	CF/CM/CU42C	875	24.0	19.2	16.25	13.25
TW4B2421S	TMLV080C16MP12C	21	CF/CM/CU42D	875	24.0	19.2	16.25	13.25
TW4B2421S	TMLV100C16MP12C	21	CF/CM/CU30C	875	24.0	19.3	16.25	13.25
TW4B2421S	TMLV100C16MP12C	21	CF/CM/CU30D	875	24.0	19.3	16.25	13.25
TW4B2421S	TMLV100C16MP12C	21	CF/CM/CU36C	875	24.0	19.2	16.25	13.25
TW4B2421S	TMLV100C16MP12C	21	CF/CM/CU36D	875	24.0	19.2	16.25	13.25
TW4B2421S	TMLV100C16MP12C	21	CF/CM/CU42C	875	24.0	19.2	16.25	13.25
TW4B2421S	TMLV100C16MP12C	21	CF/CM/CU42D	875	24.0	19.2	16.25	13.25
TW4B2421S	TMLX060A12MP11	14.5	CF/CM/CU24A	750	24.0	18.1	15.50	13.00
TW4B2421S	TMLX060A12MP11	14.5	CF/CM/CU30A	750	24.0	18.2	15.75	13.25
TW4B2421S	TMLX060A12MP11	14.5	CF/CM36A	775	24.0	18.2	16.25	13.25
TW4B2421S	TMLX080B12MP11	17.5	CF/CM/CU24B	775	24.0	18.3	16.00	13.00
TW4B2421S	TMLX080B12MP11	17.5	CF/CM/CU30B	825	24.0	18.6	16.25	13.25
TW4B2421S	TMLX080B12MP11	17.5	CF/CM/CU36B	775	24.0	18.2	16.25	13.25
TW4B2421S	TMLX080B12MP11	17.5	CF42B	825	24.0	19.0	16.25	13.25
TW4B2421S	TMLX080C16MP11	21	CF/CM/CU24C	700	24.0	17.6	16.00	13.25
TW4B2421S	TMLX080C16MP11	21	CF/CM/CU30C	700	24.0	18.0	16.25	13.25
TW4B2421S	TMLX080C16MP11	21	CF/CM/CU30D	725	24.0	17.9	16.25	13.25
TW4B2421S	TMLX080C16MP11	21	CF/CM/CU36C	700	24.0	17.4	16.25	13.25

COOLING CAPACITY - With High Efficiency Motor Furnaces¹ (Continued)

UNIT MODEL	FURNACE		COIL MODEL ²	COOLING				
	MODEL	WIDTH		RATED CFM	NET MBH		SEER	EER
					TOTAL	SENS.		
TW4B2421S	TMLX080C16MP11	21	CF/CM/CU36D	725	24.0	17.7	16.25	13.25
TW4B2421S	TMLX080C16MP11	21	CF/CM/CU42C	700	24.0	17.6	16.25	13.25
TW4B2421S	TMLX080C16MP11	21	CF/CM/CU42D	725	24.0	17.9	16.25	13.25
TW4B2421S	TMLX100C16MP11	21	CF/CM/CU24C	700	24.0	17.6	16.00	13.25
TW4B2421S	TMLX100C16MP11	21	CF/CM/CU30C	700	24.0	18.0	16.25	13.25
TW4B2421S	TMLX100C16MP11	21	CF/CM/CU30D	725	24.0	17.9	16.25	13.25
TW4B2421S	TMLX100C16MP11	21	CF/CM/CU36C	700	24.0	17.4	16.25	13.25
TW4B2421S	TMLX100C16MP11	21	CF/CM/CU36D	725	24.0	17.7	16.25	13.25
TW4B2421S	TMLX100C16MP11	21	CF/CM/CU42C	700	24.0	17.6	16.25	13.25
TW4B2421S	TMLX100C16MP11	21	CF/CM/CU42D	725	24.0	17.9	16.25	13.25
TW4B2421S	TP9C060B12MP13C	17.5	CF/CM/CU24B	600	24.0	16.6	15.75	13.00
TW4B2421S	TP9C060B12MP13C	17.5	CF/CM/CU30B	700	24.0	18.0	16.00	13.25
TW4B2421S	TP9C060B12MP13C	17.5	CF/CM/CU36B	700	24.0	17.5	16.25	13.50
TW4B2421S	TP9C060B12MP13C	17.5	CF/CM/CU36C	700	24.0	17.5	16.25	13.50
TW4B2421S	TP9C060B12MP13C	17.5	CF/CM/CU42C	700	24.0	17.6	16.25	13.50
TW4B2421S	TP9C060B12MP13C	17.5	CF/CM24C	700	24.0	17.7	15.75	13.25
TW4B2421S	TP9C060B12MP13C	17.5	CF/CM30C	700	24.0	18.0	16.25	13.50
TW4B2421S	TP9C060B12MP13C	17.5	CF42B	700	24.0	17.6	16.25	13.50
TW4B2421S	TP9C080B12MP13C	17.5	CF/CM/CU24B	800	24.0	18.5	16.00	13.25
TW4B2421S	TP9C080B12MP13C	17.5	CF/CM/CU30B	800	24.0	18.6	16.00	13.25
TW4B2421S	TP9C080B12MP13C	17.5	CF/CM/CU36B	800	24.0	18.5	16.25	13.25
TW4B2421S	TP9C080B12MP13C	17.5	CF42B	800	24.0	18.6	16.25	13.25
TW4B2421S	TP9C080C16MP13C	21	CF/CM/CU36C	950	24.0	20.0	16.25	13.25
TW4B2421S	TP9C080C16MP13C	21	CF/CM/CU42C	950	24.0	19.7	16.25	13.25
TW4B2421S	TP9C080C16MP13C	21	CF/CM24C	950	24.0	19.1	15.25	12.50
TW4B2421S	TP9C080C16MP13C	21	CF/CM30C	950	24.0	19.9	16.25	13.25
TW4B2421S	TP9C080C16MP13C	21	CF/CM36D	950	24.0	20.0	16.25	13.25
TW4B2421S	TP9C080C16MP13C	21	CF/CM42D	950	24.0	19.7	16.25	13.25
TW4B2421S	TPLC060A12MP13C	14.5	CF/CM/CU24A	800	24.0	18.5	15.25	12.50
TW4B2421S	TPLC060A12MP13C	14.5	CF/CM/CU30A	800	24.0	18.6	15.75	12.75
TW4B2421S	TPLC060A12MP13C	14.5	CF/CM36A	800	24.0	18.5	16.25	13.25
TW4B2421S	TPLC080B12MP13C	17.5	CF/CM/CU24B	825	24.0	18.8	15.50	12.75
TW4B2421S	TPLC080B12MP13C	17.5	CF/CM/CU30B	825	24.0	18.7	16.00	13.00
TW4B2421S	TPLC080B12MP13C	17.5	CF/CM/CU36B	825	24.0	18.6	16.00	13.00
TW4B2421S	TPLC080B12MP13C	17.5	CF42B	825	24.0	19.0	16.25	13.25
TW4B2421S	TPLC080C16MP13C	21	CF/CM/CU30C	875	24.0	19.3	16.25	13.25
TW4B2421S	TPLC080C16MP13C	21	CF/CM/CU30D	875	24.0	19.3	16.25	13.25
TW4B2421S	TPLC080C16MP13C	21	CF/CM/CU36C	875	24.0	19.2	16.25	13.25
TW4B2421S	TPLC080C16MP13C	21	CF/CM/CU36D	875	24.0	19.2	16.25	13.25
TW4B2421S	TPLC080C16MP13C	21	CF/CM/CU42C	875	24.0	19.2	16.25	13.25
TW4B2421S	TPLC080C16MP13C	21	CF/CM/CU42D	875	24.0	19.2	16.25	13.25
TW4B2421S	TPLC100C16MP13C	21	CF/CM/CU30C	875	24.0	19.3	16.25	13.25
TW4B2421S	TPLC100C16MP13C	21	CF/CM/CU30D	875	24.0	19.3	16.25	13.25
TW4B2421S	TPLC100C16MP13C	21	CF/CM/CU36C	875	24.0	19.2	16.25	13.25
TW4B2421S	TPLC100C16MP13C	21	CF/CM/CU36D	875	24.0	19.2	16.25	13.25
TW4B2421S	TPLC100C16MP13C	21	CF/CM/CU42C	875	24.0	19.2	16.25	13.25
TW4B2421S	TPLC100C16MP13C	21	CF/CM/CU42D	875	24.0	19.2	16.25	13.25
TW4B2421S	CP9C060B12MP13C	17.5	CF/CM/CU24B	600	24.0	16.6	15.75	13.00
TW4B2421S	CP9C060B12MP13C	17.5	CF/CM/CU30B	700	24.0	18.0	16.00	13.25
TW4B2421S	CP9C060B12MP13C	17.5	CF/CM/CU36B	700	24.0	17.5	16.25	13.50
TW4B2421S	CP9C060B12MP13C	17.5	CF/CM/CU36C	700	24.0	17.5	16.25	13.50
TW4B2421S	CP9C060B12MP13C	17.5	CF/CM/CU42C	700	24.0	17.6	16.25	13.50
TW4B2421S	CP9C060B12MP13C	17.5	CF/CM24C	700	24.0	17.7	15.75	13.25

COOLING CAPACITY - With High Efficiency Motor Furnaces¹ (Continued)

UNIT MODEL	FURNACE		COIL MODEL ²	COOLING				
	MODEL	WIDTH		RATED CFM	NET MBH		SEER	EER
					TOTAL	SENS.		
TW4B2421S	CP9C060B12MP13C	17.5	CF/CM30C	700	24.0	18.0	16.25	13.50
TW4B2421S	CP9C060B12MP13C	17.5	CF42B	700	24.0	17.6	16.25	13.50
TW4B2421S	CP9C080B12MP13C	17.5	CF/CM/CU24B	800	24.0	18.5	16.00	13.25
TW4B2421S	CP9C080B12MP13C	17.5	CF/CM/CU30B	800	24.0	18.6	16.00	13.25
TW4B2421S	CP9C080B12MP13C	17.5	CF/CM/CU36B	800	24.0	18.5	16.25	13.25
TW4B2421S	CP9C080B12MP13C	17.5	CF42B	800	24.0	18.6	16.25	13.25
TW4B2421S	CP9C080C16MP13C	21	CF/CM/CU36C	950	24.0	20.0	16.25	13.25
TW4B2421S	CP9C080C16MP13C	21	CF/CM/CU42C	950	24.0	19.7	16.25	13.25
TW4B2421S	CP9C080C16MP13C	21	CF/CM24C	950	24.0	19.1	15.25	12.50
TW4B2421S	CP9C080C16MP13C	21	CF/CM30C	950	24.0	19.9	16.25	13.25
TW4B2421S	CP9C080C16MP13C	21	CF/CM36D	950	24.0	20.0	16.25	13.25
TW4B2421S	CP9C080C16MP13C	21	CF/CM42D	950	24.0	19.7	16.25	13.25
TW4B2421S	CPLC060A12MP13C	14.5	CF/CM/CU24A	800	24.0	18.5	15.25	12.50
TW4B2421S	CPLC060A12MP13C	14.5	CF/CM/CU30A	800	24.0	18.6	15.75	12.75
TW4B2421S	CPLC060A12MP13C	14.5	CF/CM36A	800	24.0	18.5	16.25	13.25
TW4B2421S	CPLC080B12MP13C	17.5	CF/CM/CU24B	825	24.0	18.8	15.50	12.75
TW4B2421S	CPLC080B12MP13C	17.5	CF/CM/CU30B	825	24.0	18.7	16.00	13.00
TW4B2421S	CPLC080B12MP13C	17.5	CF/CM/CU36B	825	24.0	18.6	16.00	13.00
TW4B2421S	CPLC080B12MP13C	17.5	CF42B	825	24.0	19.0	16.25	13.25
TW4B2421S	CPLC080C16MP13C	21	CF/CM/CU30C	875	24.0	19.3	16.25	13.25
TW4B2421S	CPLC080C16MP13C	21	CF/CM/CU30D	875	24.0	19.3	16.25	13.25
TW4B2421S	CPLC080C16MP13C	21	CF/CM/CU36C	875	24.0	19.2	16.25	13.25
TW4B2421S	CPLC080C16MP13C	21	CF/CM/CU36D	875	24.0	19.2	16.25	13.25
TW4B2421S	CPLC080C16MP13C	21	CF/CM/CU42C	875	24.0	19.2	16.25	13.25
TW4B2421S	CPLC080C16MP13C	21	CF/CM/CU42D	875	24.0	19.2	16.25	13.25
TW4B2421S	CPLC100C16MP13C	21	CF/CM/CU30C	875	24.0	19.3	16.25	13.25
TW4B2421S	CPLC100C16MP13C	21	CF/CM/CU30D	875	24.0	19.3	16.25	13.25
TW4B2421S	CPLC100C16MP13C	21	CF/CM/CU36C	875	24.0	19.2	16.25	13.25
TW4B2421S	CPLC100C16MP13C	21	CF/CM/CU36D	875	24.0	19.2	16.25	13.25
TW4B2421S	CPLC100C16MP13C	21	CF/CM/CU42C	875	24.0	19.2	16.25	13.25
TW4B2421S	CPLC100C16MP13C	21	CF/CM/CU42D	875	24.0	19.2	16.25	13.25
TW4B3021S	TL8E060A12UH11	14.5	CF/CM/CU30B	850	28.8	21.6	14.75	12.50
TW4B3021S	TL8E060A12UH11	14.5	CF/CM/CU36B	850	29.0	21.8	15.00	12.50
TW4B3021S	TL8E060A12UH11	14.5	CF42B	850	29.0	21.6	15.00	12.50
TW4B3021S	TL8E080C16UH11	21.0	CF/CM/CU36C	950	29.6	23.4	15.50	12.75
TW4B3021S	TL8E080C16UH11	21.0	CF/CM/CU42C	950	29.6	23.0	15.50	12.75
TW4B3021S	TL8E080C16UH11	21.0	CF/CM30C	925	29.0	22.6	15.25	12.50
TW4B3021S	TL8E080C16UH11	21.0	CF/CM36D	950	29.6	23.4	15.25	12.50
TW4B3021S	TL8E080C16UH11	21.0	CF/CM42D	950	29.6	23.0	15.50	12.75
TW4B3021S	TL8E100C20UH11	21.0	CF/CM/CU36C	1050	29.8	24.4	15.50	12.75
TW4B3021S	TL8E100C20UH11	21.0	CF/CM/CU42C	1050	30.0	24.2	15.50	12.75
TW4B3021S	TL8E100C20UH11	21.0	CF/CM30C	1050	29.6	24.2	15.50	12.75
TW4B3021S	TL8E100C20UH11	21.0	CF/CM36D	1050	29.8	24.4	15.50	12.75
TW4B3021S	TL8E100C20UH11	21.0	CF/CM42D	1050	30.0	24.2	15.50	12.75
TW4B3021S	TL9E060B12UH11	17.5	CF/CM/CU30B	850	28.8	21.6	14.75	12.50
TW4B3021S	TL9E060B12UH11	17.5	CF/CM/CU36B	850	29.0	21.8	14.75	12.50
TW4B3021S	TL9E060B12UH11	17.5	CF/CM/CU36C	875	29.0	22.0	14.75	12.50
TW4B3021S	TL9E060B12UH11	17.5	CF/CM/CU42C	875	29.2	22.0	14.75	12.50
TW4B3021S	TL9E060B12UH11	17.5	CF/CM30C	850	28.8	21.6	14.50	12.50
TW4B3021S	TL9E060B12UH11	17.5	CF42B	850	29.0	21.6	14.75	12.50
TW4B3021S	TL9E080C16UH11	21.0	CF/CM/CU36C	900	29.2	22.6	15.50	12.75
TW4B3021S	TL9E080C16UH11	21.0	CF/CM/CU42C	900	29.4	22.4	15.50	12.75
TW4B3021S	TL9E080C16UH11	21.0	CF/CM30C	900	29.2	22.4	15.25	12.50

COOLING CAPACITY - With High Efficiency Motor Furnaces¹ (Continued)

UNIT MODEL	FURNACE		COIL MODEL ²	COOLING				
	MODEL	WIDTH		RATED CFM	NET MBH		SEER	EER
					TOTAL	SENS.		
TW4B3021S	TL9E080C16UH11	21.0	CF/CM36D	900	29.2	22.6	15.25	12.50
TW4B3021S	TL9E080C16UH11	21.0	CF/CM42D	900	29.4	22.4	15.25	12.50
TW4B3021S	TL9E100C20UH11	21.0	CF/CM/CU36C	1125	29.6	24.6	15.25	12.50
TW4B3021S	TL9E100C20UH11	21.0	CF/CM/CU42C	1125	30.0	25.2	15.50	12.75
TW4B3021S	TL9E100C20UH11	21.0	CF/CM30C	1125	29.4	25.0	15.25	12.50
TW4B3021S	TL9E100C20UH11	21.0	CF/CM36D	1150	29.6	24.8	15.25	12.50
TW4B3021S	TL9E100C20UH11	21.0	CF/CM42D	1150	30.0	25.2	15.25	12.50
TW4B3021S	TM8E040A12MP11	14.5	CF/CM/CU30B	875	29.0	21.8	15.00	12.50
TW4B3021S	TM8E040A12MP11	14.5	CF/CM/CU36B	875	29.2	22.4	15.00	12.50
TW4B3021S	TM8E040A12MP11	14.5	CF42B	850	29.2	21.8	15.00	12.50
TW4B3021S	TM8E060A12MP11	14.5	CF/CM/CU30B	875	29.0	21.8	15.00	12.50
TW4B3021S	TM8E060A12MP11	14.5	CF/CM/CU36B	875	29.2	22.4	15.00	12.50
TW4B3021S	TM8E060A12MP11	14.5	CF42B	850	29.0	21.6	15.00	12.50
TW4B3021S	TM8E080B12MP11	17.5	CF/CM/CU30B	900	29.2	22.4	15.00	12.50
TW4B3021S	TM8E080B12MP11	17.5	CF/CM/CU36B	875	29.0	22.2	15.00	12.50
TW4B3021S	TM8E080B12MP11	17.5	CF/CM/CU36C	900	29.2	22.6	15.00	12.50
TW4B3021S	TM8E080B12MP11	17.5	CF/CM/CU42C	900	29.4	22.4	15.00	12.50
TW4B3021S	TM8E080B12MP11	17.5	CF/CM30C	900	29.2	22.4	15.00	12.50
TW4B3021S	TM8E080B12MP11	17.5	CF42B	875	29.2	22.0	15.00	12.50
TW4B3021S	TM8E080C16MP11	21.0	CF/CM/CU36C	950	29.6	23.4	15.50	12.75
TW4B3021S	TM8E080C16MP11	21.0	CF/CM/CU42C	950	29.6	23.0	15.50	12.75
TW4B3021S	TM8E080C16MP11	21.0	CF/CM30C	950	29.2	22.6	15.25	12.50
TW4B3021S	TM8E080C16MP11	21.0	CF/CM36D	950	29.6	23.4	15.25	12.50
TW4B3021S	TM8E080C16MP11	21.0	CF/CM42D	950	29.6	23.0	15.50	12.75
TW4B3021S	TM8E100B12MP11	17.5	CF/CM/CU30B	825	28.8	21.4	15.25	12.50
TW4B3021S	TM8E100B12MP11	17.5	CF/CM/CU36B	825	28.8	21.4	15.25	12.50
TW4B3021S	TM8E100B12MP11	17.5	CF/CM/CU36C	925	29.4	22.6	15.25	12.50
TW4B3021S	TM8E100B12MP11	17.5	CF/CM/CU42C	850	29.2	21.8	15.25	12.50
TW4B3021S	TM8E100B12MP11	17.5	CF/CM30C	825	28.8	21.4	15.00	12.50
TW4B3021S	TM8E100B12MP11	17.5	CF42B	875	29.2	22.0	15.00	12.50
TW4B3021S	TM8E100C16MP11	21.0	CF/CM/CU36C	925	29.4	22.6	15.50	12.75
TW4B3021S	TM8E100C16MP11	21.0	CF/CM/CU42C	925	29.6	22.8	15.50	12.75
TW4B3021S	TM8E100C16MP11	21.0	CF/CM30C	925	29.0	22.6	15.25	12.50
TW4B3021S	TM8E100C16MP11	21.0	CF/CM36D	950	29.6	23.4	15.50	12.75
TW4B3021S	TM8E100C16MP11	21.0	CF/CM42D	950	29.8	23.4	15.50	12.75
TW4B3021S	TM8E120C16MP11	21.0	CF/CM/CU36C	950	29.6	23.4	15.50	12.75
TW4B3021S	TM8E120C16MP11	21.0	CF/CM/CU42C	950	29.6	23.2	15.50	12.75
TW4B3021S	TM8E120C16MP11	21.0	CF/CM30C	950	29.2	22.6	15.25	12.50
TW4B3021S	TM8E120C16MP11	21.0	CF/CM36D	950	29.6	23.4	15.50	12.75
TW4B3021S	TM8E120C16MP11	21.0	CF/CM42D	950	29.8	23.4	15.50	12.75
TW4B3021S	TM8V060A12MP12C	14.5	CF/CM/CU30A	875	28.0	21.0	14.25	12.25
TW4B3021S	TM8V060A12MP12C	14.5	CF/CM36A	875	28.4	21.6	14.75	12.50
TW4B3021S	TM8V080B12MP12C	17.5	CF/CM/CU30B	900	28.4	21.8	14.25	12.25
TW4B3021S	TM8V080B12MP12C	17.5	CF/CM/CU36B	900	28.4	22.0	14.50	12.50
TW4B3021S	TM8V080B12MP12C	17.5	CF42B	900	28.6	21.8	14.75	12.50
TW4B3021S	TM8V080C16MP12C	21.0	CF/CM/CU30C	950	29.0	22.6	15.25	12.50
TW4B3021S	TM8V080C16MP12C	21.0	CF/CM/CU30D	950	29.0	22.6	15.25	13.00
TW4B3021S	TM8V080C16MP12C	21.0	CF/CM/CU36C	950	29.2	23.0	15.25	12.75
TW4B3021S	TM8V080C16MP12C	21.0	CF/CM/CU36D	950	29.2	23.0	15.25	13.00
TW4B3021S	TM8V080C16MP12C	21.0	CF/CM/CU42C	950	29.4	23.0	15.25	12.75
TW4B3021S	TM8V080C16MP12C	21.0	CF/CM/CU42D	950	29.4	23.0	15.50	13.25
TW4B3021S	TM8V100C16MP12C	21.0	CF/CM/CU30C	950	29.0	22.6	15.25	12.50
TW4B3021S	TM8V100C16MP12C	21.0	CF/CM/CU30D	950	29.0	22.6	15.25	13.00

COOLING CAPACITY - With High Efficiency Motor Furnaces¹ (Continued)

UNIT MODEL	FURNACE		COIL MODEL ²	COOLING				
	MODEL	WIDTH		RATED CFM	NET MBH		SEER	EER
					TOTAL	SENS.		
TW4B3021S	TM8V100C16MP12C	21.0	CF/CM/CU36C	950	29.2	23.0	15.25	12.75
TW4B3021S	TM8V100C16MP12C	21.0	CF/CM/CU36D	950	29.2	23.0	15.25	13.00
TW4B3021S	TM8V100C16MP12C	21.0	CF/CM/CU42C	950	29.4	23.0	15.25	12.75
TW4B3021S	TM8V100C16MP12C	21.0	CF/CM/CU42D	950	29.4	23.0	15.50	13.25
TW4B3021S	TM8X060A12MP11	14.5	CF/CM/CU30A	875	28.0	21.0	14.50	12.50
TW4B3021S	TM8X060A12MP11	14.5	CF/CM36A	875	28.2	21.4	14.75	12.50
TW4B3021S	TM8X080B12MP11	17.5	CF/CM/CU30B	975	29.4	23.4	15.00	12.50
TW4B3021S	TM8X080B12MP11	17.5	CF/CM/CU36B	975	29.6	22.8	15.25	12.50
TW4B3021S	TM8X080B12MP11	17.5	CF42B	950	29.2	22.8	15.00	12.50
TW4B3021S	TM8X080C16MP11	21.0	CF/CM/CU30C	950	29.0	22.6	15.50	12.75
TW4B3021S	TM8X080C16MP11	21.0	CF/CM/CU30D	975	29.4	23.4	15.50	12.75
TW4B3021S	TM8X080C16MP11	21.0	CF/CM/CU36C	950	29.2	23.0	15.50	12.75
TW4B3021S	TM8X080C16MP11	21.0	CF/CM/CU36D	975	29.8	22.8	15.75	13.00
TW4B3021S	TM8X080C16MP11	21.0	CF/CM/CU42C	950	29.4	23.0	15.50	12.75
TW4B3021S	TM8X080C16MP11	21.0	CF/CM/CU42D	975	29.8	23.4	15.75	13.00
TW4B3021S	TM8X100C16MP11	21.0	CF/CM/CU30C	950	29.0	22.6	15.50	12.75
TW4B3021S	TM8X100C16MP11	21.0	CF/CM/CU30D	975	29.4	23.4	15.50	12.75
TW4B3021S	TM8X100C16MP11	21.0	CF/CM/CU36C	950	29.2	23.0	15.50	12.75
TW4B3021S	TM8X100C16MP11	21.0	CF/CM/CU36D	975	29.8	22.8	15.75	13.00
TW4B3021S	TM8X100C16MP11	21.0	CF/CM/CU42C	950	29.4	23.0	15.50	12.75
TW4B3021S	TM8X100C16MP11	21.0	CF/CM/CU42D	975	29.8	23.4	15.75	13.00
TW4B3021S	TM8X100C20MP11	21.0	CF/CM/CU30C	1000	29.6	23.6	15.50	12.75
TW4B3021S	TM8X100C20MP11	21.0	CF/CM/CU30D	1000	29.6	23.6	15.50	12.75
TW4B3021S	TM8X100C20MP11	21.0	CF/CM/CU36C	1000	29.6	24.0	15.75	13.00
TW4B3021S	TM8X100C20MP11	21.0	CF/CM/CU36D	1000	29.8	24.2	15.75	13.00
TW4B3021S	TM8X100C20MP11	21.0	CF/CM/CU42C	1000	30.0	23.8	15.75	13.00
TW4B3021S	TM8X100C20MP11	21.0	CF/CM/CU42D	1000	30.0	23.8	15.75	13.00
TW4B3021S	TM8X120C20MP11	21.0	CF/CM/CU30C	1000	29.6	23.6	15.50	12.75
TW4B3021S	TM8X120C20MP11	21.0	CF/CM/CU30D	1000	29.6	23.6	15.50	12.75
TW4B3021S	TM8X120C20MP11	21.0	CF/CM/CU36C	1000	29.6	24.0	15.75	13.00
TW4B3021S	TM8X120C20MP11	21.0	CF/CM/CU36D	1000	29.8	24.2	15.75	13.00
TW4B3021S	TM8X120C20MP11	21.0	CF/CM/CU42C	1000	30.0	23.8	15.75	13.00
TW4B3021S	TM8X120C20MP11	21.0	CF/CM/CU42D	1000	30.0	23.8	15.75	13.00
TW4B3021S	TM8Y060A12MP11	14.5	CF/CM/CU30A	875	28.0	21.0	14.50	12.50
TW4B3021S	TM8Y060A12MP11	14.5	CF/CM36A	875	28.2	21.4	14.75	12.50
TW4B3021S	TM8Y080B12MP11	17.5	CF/CM/CU30B	975	29.4	23.4	15.00	12.50
TW4B3021S	TM8Y080B12MP11	17.5	CF/CM/CU36B	975	29.6	22.8	15.25	12.50
TW4B3021S	TM8Y080B12MP11	17.5	CF42B	950	29.2	22.8	15.00	12.50
TW4B3021S	TM8Y080C16MP11	21.0	CF/CM/CU30C	950	29.0	22.6	15.50	12.75
TW4B3021S	TM8Y080C16MP11	21.0	CF/CM/CU30D	975	29.4	23.4	15.50	12.75
TW4B3021S	TM8Y080C16MP11	21.0	CF/CM/CU36C	950	29.2	23.0	15.50	12.75
TW4B3021S	TM8Y080C16MP11	21.0	CF/CM/CU36D	975	29.8	22.8	15.75	13.00
TW4B3021S	TM8Y080C16MP11	21.0	CF/CM/CU42C	950	29.4	23.0	15.50	12.75
TW4B3021S	TM8Y080C16MP11	21.0	CF/CM/CU42D	975	29.8	23.4	15.75	13.00
TW4B3021S	TM8Y100C16MP11	21.0	CF/CM/CU30C	950	29.0	22.6	15.50	12.75
TW4B3021S	TM8Y100C16MP11	21.0	CF/CM/CU30D	975	29.4	23.4	15.50	12.75
TW4B3021S	TM8Y100C16MP11	21.0	CF/CM/CU36C	950	29.2	23.0	15.50	12.75
TW4B3021S	TM8Y100C16MP11	21.0	CF/CM/CU36D	975	29.8	22.8	15.75	13.00
TW4B3021S	TM8Y100C16MP11	21.0	CF/CM/CU42C	950	29.4	23.0	15.50	12.75
TW4B3021S	TM8Y100C16MP11	21.0	CF/CM/CU42D	975	29.8	23.4	15.75	13.00
TW4B3021S	TM8Y100C20MP11	21.0	CF/CM/CU30C	1000	29.6	23.6	15.50	12.75
TW4B3021S	TM8Y100C20MP11	21.0	CF/CM/CU30D	1000	29.6	23.6	15.50	12.75
TW4B3021S	TM8Y100C20MP11	21.0	CF/CM/CU36C	1000	29.6	24.0	15.75	13.00

COOLING CAPACITY - With High Efficiency Motor Furnaces¹ (Continued)

UNIT MODEL	FURNACE		COIL MODEL ²	COOLING				
	MODEL	WIDTH		RATED CFM	NET MBH		SEER	EER
					TOTAL	SENS.		
TW4B3021S	TM8Y100C20MP11	21.0	CF/CM/CU36D	1000	29.8	24.2	15.75	13.00
TW4B3021S	TM8Y100C20MP11	21.0	CF/CM/CU42C	1000	30.0	23.8	15.75	13.00
TW4B3021S	TM8Y100C20MP11	21.0	CF/CM/CU42D	1000	30.0	23.8	15.75	13.00
TW4B3021S	TM8Y120C20MP11	21.0	CF/CM/CU30C	1000	29.6	23.6	15.50	12.75
TW4B3021S	TM8Y120C20MP11	21.0	CF/CM/CU30D	1000	29.6	23.6	15.50	12.75
TW4B3021S	TM8Y120C20MP11	21.0	CF/CM/CU36C	1000	29.6	24.0	15.75	13.00
TW4B3021S	TM8Y120C20MP11	21.0	CF/CM/CU36D	1000	29.8	24.2	15.75	13.00
TW4B3021S	TM8Y120C20MP11	21.0	CF/CM/CU42C	1000	30.0	23.8	15.75	13.00
TW4B3021S	TM8Y120C20MP11	21.0	CF/CM/CU42D	1000	30.0	23.8	15.75	13.00
TW4B3021S	TM9E040A10MP12	14.5	CF/CM/CU30B	850	28.6	21.6	14.00	12.20
TW4B3021S	TM9E040A10MP12	14.5	CF/CM/CU36B	850	28.8	21.8	14.25	12.20
TW4B3021S	TM9E040A10MP12	14.5	CF42B	850	28.8	21.6	14.25	12.25
TW4B3021S	TM9E060A10MP12	14.5	CF/CM/CU30B	825	28.6	21.2	14.50	12.50
TW4B3021S	TM9E060A10MP12	14.5	CF/CM/CU36B	825	28.6	21.4	14.75	12.50
TW4B3021S	TM9E060A10MP12	14.5	CF42B	825	29.0	21.4	14.75	12.50
TW4B3021S	TM9E060B12MP11	17.5	CF/CM/CU30B	850	28.8	21.6	15.00	12.50
TW4B3021S	TM9E060B12MP11	17.5	CF/CM/CU36B	850	28.8	21.6	15.00	12.50
TW4B3021S	TM9E060B12MP11	17.5	CF/CM/CU36C	875	29.0	22.0	15.00	12.50
TW4B3021S	TM9E060B12MP11	17.5	CF/CM/CU42C	875	29.2	22.0	15.00	12.50
TW4B3021S	TM9E060B12MP11	17.5	CF/CM30C	875	28.8	21.6	15.00	12.50
TW4B3021S	TM9E060B12MP11	17.5	CF42B	850	29.0	21.6	15.00	12.50
TW4B3021S	TM9E060B12MP12	17.5	CF/CM/CU30B	925	28.8	22.4	14.50	12.50
TW4B3021S	TM9E060B12MP12	17.5	CF/CM/CU36B	925	29.2	22.6	14.75	12.50
TW4B3021S	TM9E060B12MP12	17.5	CF/CM/CU36C	950	29.2	23.0	14.50	12.50
TW4B3021S	TM9E060B12MP12	17.5	CF/CM/CU42C	950	29.4	23.0	14.75	12.50
TW4B3021S	TM9E060B12MP12	17.5	CF/CM30C	950	29.0	22.6	14.50	12.25
TW4B3021S	TM9E060B12MP12	17.5	CF42B	925	29.2	22.4	14.75	12.50
TW4B3021S	TM9E080B12MP11	17.5	CF/CM/CU30B	975	29.2	23.2	15.00	12.50
TW4B3021S	TM9E080B12MP11	17.5	CF/CM/CU36B	975	29.6	22.8	15.25	12.75
TW4B3021S	TM9E080B12MP11	17.5	CF42B	975	29.6	23.2	15.25	12.75
TW4B3021S	TM9E080B12MP12	17.5	CF/CM/CU30B	925	29.0	22.8	14.75	12.50
TW4B3021S	TM9E080B12MP12	17.5	CF/CM/CU36B	925	29.2	22.6	15.00	12.50
TW4B3021S	TM9E080B12MP12	17.5	CF/CM/CU36C	950	29.4	23.2	15.00	12.50
TW4B3021S	TM9E080B12MP12	17.5	CF/CM/CU42C	950	29.6	23.0	15.00	12.50
TW4B3021S	TM9E080B12MP12	17.5	CF/CM30C	950	29.2	22.8	14.75	12.50
TW4B3021S	TM9E080B12MP12	17.5	CF42B	925	29.4	22.6	15.00	12.50
TW4B3021S	TM9E080C16MP11	21.0	CF/CM/CU36C	975	29.8	23.0	15.25	12.75
TW4B3021S	TM9E080C16MP11	21.0	CF/CM/CU42C	975	29.8	23.4	15.25	12.75
TW4B3021S	TM9E080C16MP11	21.0	CF/CM30C	975	29.4	23.4	15.25	12.75
TW4B3021S	TM9E080C16MP11	21.0	CF/CM36D	975	29.8	23.0	15.25	12.75
TW4B3021S	TM9E080C16MP11	21.0	CF/CM42D	975	29.8	23.4	15.25	12.75
TW4B3021S	TM9E080C16MP12	21.0	CF/CM/CU36C	875	29.2	22.4	15.25	12.50
TW4B3021S	TM9E080C16MP12	21.0	CF/CM/CU42C	875	29.4	22.2	15.25	12.50
TW4B3021S	TM9E080C16MP12	21.0	CF/CM30C	875	29.0	21.8	15.25	12.50
TW4B3021S	TM9E080C16MP12	21.0	CF/CM36D	900	29.2	22.6	15.25	12.50
TW4B3021S	TM9E080C16MP12	21.0	CF/CM42D	900	29.4	22.4	15.25	12.50
TW4B3021S	TM9E100C16MP11	21.0	CF/CM/CU30C	975	29.4	23.4	15.25	12.75
TW4B3021S	TM9E100C16MP11	21.0	CF/CM/CU30D	1000	29.6	23.6	15.25	12.75
TW4B3021S	TM9E100C16MP11	21.0	CF/CM/CU36C	975	29.8	23.0	15.25	12.75
TW4B3021S	TM9E100C16MP11	21.0	CF/CM/CU36D	1000	29.6	24.0	15.50	13.25
TW4B3021S	TM9E100C16MP11	21.0	CF/CM/CU42C	975	29.8	23.4	15.25	12.75
TW4B3021S	TM9E100C16MP11	21.0	CF/CM/CU42D	1000	30.0	23.8	15.50	13.25
TW4B3021S	TM9E100C16MP12	21.0	CF/CM/CU36C	925	29.4	22.6	15.50	12.75

COOLING CAPACITY - With High Efficiency Motor Furnaces¹ (Continued)

UNIT MODEL	FURNACE		COIL MODEL ²	COOLING				
	MODEL	WIDTH		RATED CFM	NET MBH		SEER	EER
					TOTAL	SENS.		
TW4B3021S	TM9E100C16MP12	21.0	CF/CM/CU42C	925	29.6	22.8	15.50	12.75
TW4B3021S	TM9E100C16MP12	21.0	CF/CM30C	925	29.0	22.6	15.25	12.50
TW4B3021S	TM9E100C16MP12	21.0	CF/CM36D	950	29.4	23.2	15.25	12.50
TW4B3021S	TM9E100C16MP12	21.0	CF/CM42D	950	29.6	23.0	15.25	12.50
TW4B3021S	TM9E100C20MP12	21.0	CF/CM/CU36C	1200	30.0	25.6	15.00	12.50
TW4B3021S	TM9E120D20MP11	24.5	CF/CM/CU30D	950	29.0	22.6	15.75	13.00
TW4B3021S	TM9E120D20MP11	24.5	CF/CM/CU36D	950	29.2	23.0	15.75	13.00
TW4B3021S	TM9E120D20MP11	24.5	CF/CM/CU42D	950	29.4	23.0	16.00	13.00
TW4B3021S	TM9V040A10MP11C	14.5	CF/CM/CU30B	775	28.4	20.6	14.25	12.25
TW4B3021S	TM9V040A10MP11C	14.5	CF/CM/CU36B	775	28.4	20.6	14.50	12.50
TW4B3021S	TM9V040A10MP11C	14.5	CF42B	775	28.6	20.6	14.50	12.50
TW4B3021S	TM9V040A10MP12C	14.5	CF/CM/CU30B	775	28.4	20.6	14.25	12.25
TW4B3021S	TM9V040A10MP12C	14.5	CF/CM/CU36B	775	28.4	20.6	14.50	12.50
TW4B3021S	TM9V040A10MP12C	14.5	CF42B	775	28.6	20.6	14.50	12.50
TW4B3021S	TM9V060B12MP11C	17.5	CF/CM/CU30B	775	28.4	20.6	15.00	12.50
TW4B3021S	TM9V060B12MP11C	17.5	CF/CM/CU36B	775	28.6	20.8	15.00	12.50
TW4B3021S	TM9V060B12MP11C	17.5	CF/CM/CU36C	775	28.6	20.8	15.00	12.50
TW4B3021S	TM9V060B12MP11C	17.5	CF/CM/CU42C	775	28.8	20.8	15.00	12.50
TW4B3021S	TM9V060B12MP11C	17.5	CF/CM30C	775	28.4	20.6	15.00	12.50
TW4B3021S	TM9V060B12MP11C	17.5	CF42B	775	28.6	20.6	15.00	12.50
TW4B3021S	TM9V060B12MP12C	17.5	CF/CM/CU30B	775	28.4	20.6	15.00	12.50
TW4B3021S	TM9V060B12MP12C	17.5	CF/CM/CU36B	775	28.6	20.8	15.00	12.50
TW4B3021S	TM9V060B12MP12C	17.5	CF/CM/CU36C	775	28.6	20.8	15.00	12.50
TW4B3021S	TM9V060B12MP12C	17.5	CF/CM/CU42C	775	28.8	20.8	15.00	12.50
TW4B3021S	TM9V060B12MP12C	17.5	CF/CM30C	775	28.4	20.6	15.00	12.50
TW4B3021S	TM9V060B12MP12C	17.5	CF42B	775	28.6	20.6	15.00	12.50
TW4B3021S	TM9V080B12MP12C	17.5	CF/CM/CU30B	975	29.2	23.2	15.00	12.50
TW4B3021S	TM9V080B12MP12C	17.5	CF/CM/CU36B	975	29.6	22.8	15.00	12.50
TW4B3021S	TM9V080B12MP12C	17.5	CF42B	975	29.6	23.2	15.25	12.50
TW4B3021S	TM9V080C16MP11C	21.0	CF/CM/CU36C	950	29.4	23.2	15.50	12.75
TW4B3021S	TM9V080C16MP11C	21.0	CF/CM/CU42C	950	29.6	23.0	15.50	12.75
TW4B3021S	TM9V080C16MP11C	21.0	CF/CM30C	950	29.2	22.8	15.25	12.75
TW4B3021S	TM9V080C16MP11C	21.0	CF/CM36D	950	29.4	23.2	15.25	12.75
TW4B3021S	TM9V080C16MP11C	21.0	CF/CM42D	950	29.6	23.0	15.25	12.75
TW4B3021S	TM9V080C16MP12C	21.0	CF/CM/CU36C	950	29.4	23.2	15.50	12.75
TW4B3021S	TM9V080C16MP12C	21.0	CF/CM/CU42C	950	29.6	23.0	15.50	12.75
TW4B3021S	TM9V080C16MP12C	21.0	CF/CM30C	950	29.2	22.8	15.25	12.75
TW4B3021S	TM9V080C16MP12C	21.0	CF/CM36D	950	29.4	23.2	15.25	12.75
TW4B3021S	TM9V080C16MP12C	21.0	CF/CM42D	950	29.6	23.0	15.25	12.75
TW4B3021S	TM9V100C16MP12C	21.0	CF/CM/CU30C	1000	29.6	23.6	15.25	12.75
TW4B3021S	TM9V100C16MP12C	21.0	CF/CM/CU30D	975	29.4	23.4	15.50	13.25
TW4B3021S	TM9V100C16MP12C	21.0	CF/CM/CU36C	1000	29.6	24.0	15.50	12.75
TW4B3021S	TM9V100C16MP12C	21.0	CF/CM/CU36D	975	29.8	22.8	15.50	13.25
TW4B3021S	TM9V100C16MP12C	21.0	CF/CM/CU42C	1000	30.0	23.8	15.50	12.75
TW4B3021S	TM9V100C16MP12C	21.0	CF/CM/CU42D	975	29.8	23.4	15.50	13.25
TW4B3021S	TM9V100C20MP12C	21.0	CF/CM/CU30D	1100	29.6	24.8	15.00	12.75
TW4B3021S	TM9V100C20MP12C	21.0	CF/CM/CU36C	1100	29.8	24.8	15.00	12.50
TW4B3021S	TM9V100C20MP12C	21.0	CF/CM/CU36D	1100	29.8	24.8	15.00	13.00
TW4B3021S	TM9V100C20MP12C	21.0	CF/CM/CU42C	1100	29.8	25.0	15.00	12.75
TW4B3021S	TM9V100C20MP12C	21.0	CF/CM/CU42D	1100	29.8	25.0	15.00	13.00
TW4B3021S	TM9V120D20MP12C	24.5	CF/CM/CU36D	1050	29.8	24.2	15.75	13.00
TW4B3021S	TM9V120D20MP12C	24.5	CF/CM/CU42D	1050	30.0	24.2	15.50	12.75
TW4B3021S	TM9Y060B12MP11	17.5	CF/CM/CU30B	850	28.8	21.6	15.00	12.50

COOLING CAPACITY - With High Efficiency Motor Furnaces¹ (Continued)

UNIT MODEL	FURNACE		COIL MODEL ²	COOLING				
	MODEL	WIDTH		RATED CFM	NET MBH		SEER	EER
					TOTAL	SENS.		
TW4B3021S	TM9Y060B12MP11	17.5	CF/CM/CU36B	850	28.8	21.6	15.00	12.50
TW4B3021S	TM9Y060B12MP11	17.5	CF/CM/CU36C	875	29.0	22.0	15.00	12.50
TW4B3021S	TM9Y060B12MP11	17.5	CF/CM/CU42C	875	29.2	22.0	15.00	12.50
TW4B3021S	TM9Y060B12MP11	17.5	CF/CM30C	875	28.8	21.6	15.00	12.50
TW4B3021S	TM9Y060B12MP11	17.5	CF42B	850	29.0	21.6	15.00	12.50
TW4B3021S	TM9Y080B12MP11	17.5	CF/CM/CU30B	975	29.2	23.2	15.00	12.50
TW4B3021S	TM9Y080B12MP11	17.5	CF/CM/CU36B	975	29.6	22.8	15.25	12.75
TW4B3021S	TM9Y080B12MP11	17.5	CF42B	975	29.6	23.2	15.25	12.75
TW4B3021S	TM9Y080C16MP11	21.0	CF/CM/CU36C	975	29.8	23.0	15.25	12.75
TW4B3021S	TM9Y080C16MP11	21.0	CF/CM/CU42C	975	29.8	23.4	15.25	12.75
TW4B3021S	TM9Y080C16MP11	21.0	CF/CM30C	975	29.4	23.4	15.25	12.75
TW4B3021S	TM9Y080C16MP11	21.0	CF/CM36D	975	29.8	23.0	15.25	12.75
TW4B3021S	TM9Y080C16MP11	21.0	CF/CM42D	975	29.8	23.4	15.25	12.75
TW4B3021S	TM9Y100C16MP11	21.0	CF/CM/CU30C	975	29.4	23.4	15.25	12.75
TW4B3021S	TM9Y100C16MP11	21.0	CF/CM/CU30D	1000	29.6	23.6	15.25	12.75
TW4B3021S	TM9Y100C16MP11	21.0	CF/CM/CU36C	975	29.8	23.0	15.25	12.75
TW4B3021S	TM9Y100C16MP11	21.0	CF/CM/CU36D	1000	29.6	24.0	15.50	13.25
TW4B3021S	TM9Y100C16MP11	21.0	CF/CM/CU42C	975	29.8	23.4	15.25	12.75
TW4B3021S	TM9Y100C16MP11	21.0	CF/CM/CU42D	1000	30.0	23.8	15.50	13.25
TW4B3021S	TM9Y120D20MP11	24.5	CF/CM/CU30D	950	29.0	22.6	15.75	13.00
TW4B3021S	TM9Y120D20MP11	24.5	CF/CM/CU36D	950	29.2	23.0	15.75	13.00
TW4B3021S	TM9Y120D20MP11	24.5	CF/CM/CU42D	950	29.4	23.0	16.00	13.00
TW4B3021S	TMLV060A12MP12C	14.5	CF/CM/CU30A	875	28.0	21.0	14.25	12.25
TW4B3021S	TMLV060A12MP12C	14.5	CF/CM36A	875	28.4	21.6	14.75	12.50
TW4B3021S	TMLV080B12MP12C	17.5	CF/CM/CU30B	900	28.4	21.8	14.25	12.25
TW4B3021S	TMLV080B12MP12C	17.5	CF/CM/CU36B	900	28.4	22.0	14.50	12.50
TW4B3021S	TMLV080B12MP12C	17.5	CF42B	900	28.6	21.8	14.75	12.50
TW4B3021S	TMLV080C16MP12C	21.0	CF/CM/CU30C	950	29.0	22.6	15.25	12.50
TW4B3021S	TMLV080C16MP12C	21.0	CF/CM/CU30D	950	29.0	22.6	15.25	13.00
TW4B3021S	TMLV080C16MP12C	21.0	CF/CM/CU36C	950	29.2	23.0	15.25	12.75
TW4B3021S	TMLV080C16MP12C	21.0	CF/CM/CU36D	950	29.2	23.0	15.25	13.00
TW4B3021S	TMLV080C16MP12C	21.0	CF/CM/CU42C	950	29.4	23.0	15.25	12.75
TW4B3021S	TMLV080C16MP12C	21.0	CF/CM/CU42D	950	29.4	23.0	15.50	13.25
TW4B3021S	TMLV100C16MP12C	21.0	CF/CM/CU30C	950	29.0	22.6	15.25	12.50
TW4B3021S	TMLV100C16MP12C	21.0	CF/CM/CU30D	950	29.0	22.6	15.25	13.00
TW4B3021S	TMLV100C16MP12C	21.0	CF/CM/CU36C	950	29.2	23.0	15.25	12.75
TW4B3021S	TMLV100C16MP12C	21.0	CF/CM/CU36D	950	29.2	23.0	15.25	13.00
TW4B3021S	TMLV100C16MP12C	21.0	CF/CM/CU42C	950	29.4	23.0	15.25	12.75
TW4B3021S	TMLV100C16MP12C	21.0	CF/CM/CU42D	950	29.4	23.0	15.50	13.25
TW4B3021S	TMLX060A12MP11	14.5	CF/CM/CU30A	875	28.0	21.0	14.50	12.50
TW4B3021S	TMLX060A12MP11	14.5	CF/CM36A	875	28.2	21.4	14.75	12.50
TW4B3021S	TMLX080B12MP11	17.5	CF/CM/CU30B	975	29.4	23.4	15.00	12.50
TW4B3021S	TMLX080B12MP11	17.5	CF/CM/CU36B	975	29.6	22.8	15.25	12.50
TW4B3021S	TMLX080B12MP11	17.5	CF42B	950	29.2	22.8	15.00	12.50
TW4B3021S	TMLX080C16MP11	21.0	CF/CM/CU30C	950	29.0	22.6	15.50	12.75
TW4B3021S	TMLX080C16MP11	21.0	CF/CM/CU30D	975	29.4	23.4	15.50	12.75
TW4B3021S	TMLX080C16MP11	21.0	CF/CM/CU36C	950	29.2	23.0	15.50	12.75
TW4B3021S	TMLX080C16MP11	21.0	CF/CM/CU36D	975	29.8	22.8	15.75	13.00
TW4B3021S	TMLX080C16MP11	21.0	CF/CM/CU42C	950	29.4	23.0	15.50	12.75
TW4B3021S	TMLX080C16MP11	21.0	CF/CM/CU42D	975	29.8	23.4	15.75	13.00
TW4B3021S	TMLX100C16MP11	21.0	CF/CM/CU30C	950	29.0	22.6	15.50	12.75
TW4B3021S	TMLX100C16MP11	21.0	CF/CM/CU30D	975	29.4	23.4	15.50	12.75
TW4B3021S	TMLX100C16MP11	21.0	CF/CM/CU36C	950	29.2	23.0	15.50	12.75

COOLING CAPACITY - With High Efficiency Motor Furnaces¹ (Continued)

UNIT MODEL	FURNACE		COIL MODEL ²	COOLING				
	MODEL	WIDTH		RATED CFM	NET MBH		SEER	EER
					TOTAL	SENS.		
TW4B3021S	TMLX100C16MP11	21.0	CF/CM/CU36D	975	29.8	22.8	15.75	13.00
TW4B3021S	TMLX100C16MP11	21.0	CF/CM/CU42C	950	29.4	23.0	15.50	12.75
TW4B3021S	TMLX100C16MP11	21.0	CF/CM/CU42D	975	29.8	23.4	15.75	13.00
TW4B3021S	TMLX100C20MP11	21.0	CF/CM/CU30C	1000	29.6	23.6	15.50	12.75
TW4B3021S	TMLX100C20MP11	21.0	CF/CM/CU30D	1000	29.6	23.6	15.50	12.75
TW4B3021S	TMLX100C20MP11	21.0	CF/CM/CU36C	1000	29.6	24.0	15.75	13.00
TW4B3021S	TMLX100C20MP11	21.0	CF/CM/CU36D	1000	29.8	24.2	15.75	13.00
TW4B3021S	TMLX100C20MP11	21.0	CF/CM/CU42C	1000	30.0	23.8	15.75	13.00
TW4B3021S	TMLX100C20MP11	21.0	CF/CM/CU42D	1000	30.0	23.8	15.75	13.00
TW4B3021S	TMLX120C20MP11	21.0	CF/CM/CU30C	1000	29.6	23.6	15.50	12.75
TW4B3021S	TMLX120C20MP11	21.0	CF/CM/CU30D	1000	29.6	23.6	15.50	12.75
TW4B3021S	TMLX120C20MP11	21.0	CF/CM/CU36C	1000	29.6	24.0	15.75	13.00
TW4B3021S	TMLX120C20MP11	21.0	CF/CM/CU36D	1000	29.8	24.2	15.75	13.00
TW4B3021S	TMLX120C20MP11	21.0	CF/CM/CU42C	1000	30.0	23.8	15.75	13.00
TW4B3021S	TMLX120C20MP11	21.0	CF/CM/CU42D	1000	30.0	23.8	15.75	13.00
TW4B3021S	TP9C060B12MP13C	17.5	CF/CM/CU30B	775	28.4	20.6	15.00	12.50
TW4B3021S	TP9C060B12MP13C	17.5	CF/CM/CU36B	775	28.6	20.8	15.00	12.50
TW4B3021S	TP9C060B12MP13C	17.5	CF/CM/CU36C	775	28.6	20.8	15.00	12.50
TW4B3021S	TP9C060B12MP13C	17.5	CF/CM/CU42C	775	28.8	20.8	15.00	12.50
TW4B3021S	TP9C060B12MP13C	17.5	CF/CM30C	775	28.4	20.6	15.00	12.50
TW4B3021S	TP9C060B12MP13C	17.5	CF42B	775	28.6	20.6	15.00	12.50
TW4B3021S	TP9C080B12MP13C	17.5	CF/CM/CU30B	975	29.2	23.2	15.00	12.50
TW4B3021S	TP9C080B12MP13C	17.5	CF/CM/CU36B	975	29.6	22.8	15.00	12.50
TW4B3021S	TP9C080B12MP13C	17.5	CF42B	975	29.6	23.2	15.25	12.50
TW4B3021S	TP9C080C16MP13C	21.0	CF/CM/CU36C	950	29.4	23.2	15.50	12.75
TW4B3021S	TP9C080C16MP13C	21.0	CF/CM/CU42C	950	29.6	23.0	15.50	12.75
TW4B3021S	TP9C080C16MP13C	21.0	CF/CM30C	950	29.2	22.8	15.25	12.75
TW4B3021S	TP9C080C16MP13C	21.0	CF/CM36D	950	29.4	23.2	15.25	12.75
TW4B3021S	TP9C080C16MP13C	21.0	CF/CM42D	950	29.6	23.0	15.25	12.75
TW4B3021S	TP9C100C16MP13C	21.0	CF/CM/CU30C	1000	29.6	23.6	15.25	12.75
TW4B3021S	TP9C100C16MP13C	21.0	CF/CM/CU30D	975	29.4	23.4	15.50	13.25
TW4B3021S	TP9C100C16MP13C	21.0	CF/CM/CU36C	1000	29.6	24.0	15.50	12.75
TW4B3021S	TP9C100C16MP13C	21.0	CF/CM/CU36D	975	29.8	22.8	15.50	13.25
TW4B3021S	TP9C100C16MP13C	21.0	CF/CM/CU42C	1000	30.0	23.8	15.50	12.75
TW4B3021S	TP9C100C16MP13C	21.0	CF/CM/CU42D	975	29.8	23.4	15.50	13.25
TW4B3021S	TP9C100C20MP13C	21.0	CF/CM/CU30D	1100	29.6	24.8	15.00	12.75
TW4B3021S	TP9C100C20MP13C	21.0	CF/CM/CU36C	1100	29.8	24.8	15.00	12.50
TW4B3021S	TP9C100C20MP13C	21.0	CF/CM/CU36D	1100	29.8	24.8	15.00	13.00
TW4B3021S	TP9C100C20MP13C	21.0	CF/CM/CU42C	1100	29.8	25.0	15.00	12.75
TW4B3021S	TP9C100C20MP13C	21.0	CF/CM/CU42D	1100	29.8	25.0	15.00	13.00
TW4B3021S	TP9C120D20MP13C	24.5	CF/CM/CU36D	1050	29.8	24.2	15.75	13.00
TW4B3021S	TP9C120D20MP13C	24.5	CF/CM/CU42D	1050	30.0	24.2	15.50	12.75
TW4B3021S	TPLC060A12MP13C	14.5	CF/CM/CU30A	875	28.0	21.0	14.25	12.25
TW4B3021S	TPLC060A12MP13C	14.5	CF/CM36A	875	28.4	21.6	14.75	12.50
TW4B3021S	TPLC080B12MP13C	17.5	CF/CM/CU30B	900	28.4	21.8	14.25	12.25
TW4B3021S	TPLC080B12MP13C	17.5	CF/CM/CU36B	900	28.4	22.0	14.50	12.50
TW4B3021S	TPLC080B12MP13C	17.5	CF42B	900	28.6	21.8	14.75	12.50
TW4B3021S	TPLC080C16MP13C	21.0	CF/CM/CU30C	950	29.0	22.6	15.25	12.50
TW4B3021S	TPLC080C16MP13C	21.0	CF/CM/CU30D	950	29.0	22.6	15.25	13.00
TW4B3021S	TPLC080C16MP13C	21.0	CF/CM/CU36C	950	29.2	23.0	15.25	12.75
TW4B3021S	TPLC080C16MP13C	21.0	CF/CM/CU36D	950	29.2	23.0	15.25	13.00
TW4B3021S	TPLC080C16MP13C	21.0	CF/CM/CU42C	950	29.4	23.0	15.25	12.75
TW4B3021S	TPLC080C16MP13C	21.0	CF/CM/CU42D	950	29.4	23.0	15.50	13.25

COOLING CAPACITY - With High Efficiency Motor Furnaces¹ (Continued)

UNIT MODEL	FURNACE		COIL MODEL ²	COOLING				
	MODEL	WIDTH		RATED CFM	NET MBH		SEER	EER
					TOTAL	SENS.		
TW4B3021S	TPLC100C16MP13C	21.0	CF/CM/CU30C	950	29.0	22.6	15.25	12.50
TW4B3021S	TPLC100C16MP13C	21.0	CF/CM/CU30D	950	29.0	22.6	15.25	13.00
TW4B3021S	TPLC100C16MP13C	21.0	CF/CM/CU36C	950	29.2	23.0	15.25	12.75
TW4B3021S	TPLC100C16MP13C	21.0	CF/CM/CU36D	950	29.2	23.0	15.25	13.00
TW4B3021S	TPLC100C16MP13C	21.0	CF/CM/CU42C	950	29.4	23.0	15.25	12.75
TW4B3021S	TPLC100C16MP13C	21.0	CF/CM/CU42D	950	29.4	23.0	15.50	13.25
TW4B3021S	CP9C060B12MP13C	17.5	CF/CM/CU30B	775	28.4	20.6	15.00	12.50
TW4B3021S	CP9C060B12MP13C	17.5	CF/CM/CU36B	775	28.6	20.8	15.00	12.50
TW4B3021S	CP9C060B12MP13C	17.5	CF/CM/CU36C	775	28.6	20.8	15.00	12.50
TW4B3021S	CP9C060B12MP13C	17.5	CF/CM/CU42C	775	28.8	20.8	15.00	12.50
TW4B3021S	CP9C060B12MP13C	17.5	CF/CM30C	775	28.4	20.6	15.00	12.50
TW4B3021S	CP9C060B12MP13C	17.5	CF42B	775	28.6	20.6	15.00	12.50
TW4B3021S	CP9C080B12MP13C	17.5	CF/CM/CU30B	975	29.2	23.2	15.00	12.50
TW4B3021S	CP9C080B12MP13C	17.5	CF/CM/CU36B	975	29.6	22.8	15.00	12.50
TW4B3021S	CP9C080B12MP13C	17.5	CF42B	975	29.6	23.2	15.25	12.50
TW4B3021S	CP9C080C16MP13C	21.0	CF/CM/CU36C	950	29.4	23.2	15.50	12.75
TW4B3021S	CP9C080C16MP13C	21.0	CF/CM/CU42C	950	29.6	23.0	15.50	12.75
TW4B3021S	CP9C080C16MP13C	21.0	CF/CM30C	950	29.2	22.8	15.25	12.75
TW4B3021S	CP9C080C16MP13C	21.0	CF/CM36D	950	29.4	23.2	15.25	12.75
TW4B3021S	CP9C080C16MP13C	21.0	CF/CM42D	950	29.6	23.0	15.25	12.75
TW4B3021S	CP9C100C16MP13C	21.0	CF/CM/CU30C	1000	29.6	23.6	15.25	12.75
TW4B3021S	CP9C100C16MP13C	21.0	CF/CM/CU30D	975	29.4	23.4	15.50	13.25
TW4B3021S	CP9C100C16MP13C	21.0	CF/CM/CU36C	1000	29.6	24.0	15.50	12.75
TW4B3021S	CP9C100C16MP13C	21.0	CF/CM/CU36D	975	29.8	22.8	15.50	13.25
TW4B3021S	CP9C100C16MP13C	21.0	CF/CM/CU42C	1000	30.0	23.8	15.50	12.75
TW4B3021S	CP9C100C16MP13C	21.0	CF/CM/CU42D	975	29.8	23.4	15.50	13.25
TW4B3021S	CP9C100C20MP13C	21.0	CF/CM/CU30D	1100	29.6	24.8	15.00	12.75
TW4B3021S	CP9C100C20MP13C	21.0	CF/CM/CU36C	1100	29.8	24.8	15.00	12.50
TW4B3021S	CP9C100C20MP13C	21.0	CF/CM/CU36D	1100	29.8	24.8	15.00	13.00
TW4B3021S	CP9C100C20MP13C	21.0	CF/CM/CU42C	1100	29.8	25.0	15.00	12.75
TW4B3021S	CP9C100C20MP13C	21.0	CF/CM/CU42D	1100	29.8	25.0	15.00	13.00
TW4B3021S	CP9C120D20MP13C	24.5	CF/CM/CU36D	1050	29.8	24.2	15.75	13.00
TW4B3021S	CP9C120D20MP13C	24.5	CF/CM/CU42D	1050	30.0	24.2	15.50	12.75
TW4B3021S	CPLC060A12MP13C	14.5	CF/CM/CU30A	875	28.0	21.0	14.25	12.25
TW4B3021S	CPLC060A12MP13C	14.5	CF/CM36A	875	28.4	21.6	14.75	12.50
TW4B3021S	CPLC080B12MP13C	17.5	CF/CM/CU30B	900	28.4	21.8	14.25	12.25
TW4B3021S	CPLC080B12MP13C	17.5	CF/CM/CU36B	900	28.4	22.0	14.50	12.50
TW4B3021S	CPLC080B12MP13C	17.5	CF42B	900	28.6	21.8	14.75	12.50
TW4B3021S	CPLC080C16MP13C	21.0	CF/CM/CU30C	950	29.0	22.6	15.25	12.50
TW4B3021S	CPLC080C16MP13C	21.0	CF/CM/CU30D	950	29.0	22.6	15.25	13.00
TW4B3021S	CPLC080C16MP13C	21.0	CF/CM/CU36C	950	29.2	23.0	15.25	12.75
TW4B3021S	CPLC080C16MP13C	21.0	CF/CM/CU36D	950	29.2	23.0	15.25	13.00
TW4B3021S	CPLC080C16MP13C	21.0	CF/CM/CU42C	950	29.4	23.0	15.25	12.75
TW4B3021S	CPLC080C16MP13C	21.0	CF/CM/CU42D	950	29.4	23.0	15.50	13.25
TW4B3021S	CPLC100C16MP13C	21.0	CF/CM/CU30C	950	29.0	22.6	15.25	12.50
TW4B3021S	CPLC100C16MP13C	21.0	CF/CM/CU30D	950	29.0	22.6	15.25	13.00
TW4B3021S	CPLC100C16MP13C	21.0	CF/CM/CU36C	950	29.2	23.0	15.25	12.75
TW4B3021S	CPLC100C16MP13C	21.0	CF/CM/CU36D	950	29.2	23.0	15.25	13.00
TW4B3021S	CPLC100C16MP13C	21.0	CF/CM/CU42C	950	29.4	23.0	15.25	12.75
TW4B3021S	CPLC100C16MP13C	21.0	CF/CM/CU42D	950	29.4	23.0	15.50	13.25
TW4B3621S	TL8E060A12UH11	14.5	CF/CM/CU36B	1025	36.0	26.6	14.75	12.25
TW4B3621S	TL8E060A12UH11	14.5	CF42B	1025	36.0	26.0	14.75	12.50
TW4B3621S	TL8E080C16UH11	21.0	CF/CM/CU36C	1125	36.0	27.4	15.50	12.75

COOLING CAPACITY - With High Efficiency Motor Furnaces¹ (Continued)

UNIT MODEL	FURNACE		COIL MODEL ²	COOLING				
	MODEL	WIDTH		RATED CFM	NET MBH		SEER	EER
					TOTAL	SENS.		
TW4B3621S	TL8E080C16UH11	21.0	CF/CM/CU42C	1125	36.0	27.0	15.50	12.75
TW4B3621S	TL8E080C16UH11	21.0	CF/CM/CU48C	1125	36.0	27.4	15.50	12.75
TW4B3621S	TL8E080C16UH11	21.0	CF/CM/CU48D	1125	36.0	27.4	15.50	12.75
TW4B3621S	TL8E080C16UH11	21.0	CF/CM36D	1125	36.0	27.4	15.25	12.50
TW4B3621S	TL8E080C16UH11	21.0	CF/CM42D	1125	36.0	27.0	15.25	12.50
TW4B3621S	TL8E100C20UH11	21.0	CF/CM/CU36C	1050	36.0	26.8	15.75	13.00
TW4B3621S	TL8E100C20UH11	21.0	CF/CM/CU42C	1050	36.0	26.4	15.75	13.00
TW4B3621S	TL8E100C20UH11	21.0	CF/CM/CU48C	1050	36.0	26.8	15.75	13.00
TW4B3621S	TL8E100C20UH11	21.0	CF/CM/CU48D	1050	36.0	26.8	15.75	13.00
TW4B3621S	TL8E100C20UH11	21.0	CF/CM36D	1050	36.0	26.8	15.50	12.75
TW4B3621S	TL8E100C20UH11	21.0	CF/CM42D	1050	36.0	26.4	15.75	13.00
TW4B3621S	TL9E060B12UH11	17.5	CF/CM/CU36B	1025	36.0	26.8	14.75	12.25
TW4B3621S	TL9E060B12UH11	17.5	CF/CM/CU36C	1050	36.0	26.8	14.50	12.25
TW4B3621S	TL9E060B12UH11	17.5	CF/CM/CU42C	1050	36.0	26.6	14.75	12.25
TW4B3621S	TL9E060B12UH11	17.5	CF/CM/CU48C	1050	36.0	26.8	14.75	12.25
TW4B3621S	TL9E060B12UH11	17.5	CF42B	1025	36.0	26.0	14.75	12.50
TW4B3621S	TL9E080C16UH11	21.0	CF/CM/CU36C	1075	36.0	27.0	15.25	12.50
TW4B3621S	TL9E080C16UH11	21.0	CF/CM/CU42C	1075	36.0	26.6	15.25	12.50
TW4B3621S	TL9E080C16UH11	21.0	CF/CM/CU48C	1075	36.0	27.0	15.50	12.75
TW4B3621S	TL9E080C16UH11	21.0	CF/CM/CU48D	1100	36.0	27.0	15.25	12.50
TW4B3621S	TL9E080C16UH11	21.0	CF/CM36D	1100	36.0	27.2	15.25	12.50
TW4B3621S	TL9E080C16UH11	21.0	CF/CM42D	1100	36.0	26.8	15.25	12.50
TW4B3621S	TL9E100C20UH11	21.0	CF/CM/CU36C	1125	36.0	27.4	15.50	12.75
TW4B3621S	TL9E100C20UH11	21.0	CF/CM/CU42C	1125	36.0	27.0	15.75	13.00
TW4B3621S	TL9E100C20UH11	21.0	CF/CM/CU48C	1125	36.0	27.4	15.75	13.00
TW4B3621S	TL9E100C20UH11	21.0	CF/CM/CU48D	1150	36.0	27.4	15.50	12.75
TW4B3621S	TL9E100C20UH11	21.0	CF/CM36D	1150	36.0	27.6	15.50	12.75
TW4B3621S	TL9E100C20UH11	21.0	CF/CM42D	1150	36.0	27.2	15.50	12.75
TW4B3621S	TM8E040A12MP11	14.5	CF/CM/CU36B	1025	36.0	26.6	15.00	12.50
TW4B3621S	TM8E040A12MP11	14.5	CF42B	1000	36.0	26.0	15.00	12.50
TW4B3621S	TM8E060A12MP11	14.5	CF/CM/CU36B	1025	36.0	26.6	15.00	12.50
TW4B3621S	TM8E060A12MP11	14.5	CF42B	1000	36.0	26.0	15.00	12.50
TW4B3621S	TM8E080B12MP11	17.5	CF/CM/CU36B	1025	36.0	26.6	15.00	12.50
TW4B3621S	TM8E080B12MP11	17.5	CF/CM/CU36C	1050	36.0	26.8	15.00	12.50
TW4B3621S	TM8E080B12MP11	17.5	CF/CM/CU42C	1050	36.0	26.6	15.00	12.50
TW4B3621S	TM8E080B12MP11	17.5	CF/CM/CU48C	1050	36.0	26.6	15.25	12.50
TW4B3621S	TM8E080B12MP11	17.5	CF42B	1025	36.0	26.0	15.00	12.50
TW4B3621S	TM8E080C16MP11	21.0	CF/CM/CU36C	1100	36.0	27.2	15.50	12.75
TW4B3621S	TM8E080C16MP11	21.0	CF/CM/CU42C	1100	36.0	26.8	15.50	12.75
TW4B3621S	TM8E080C16MP11	21.0	CF/CM/CU48C	1100	36.0	27.0	15.75	13.00
TW4B3621S	TM8E080C16MP11	21.0	CF/CM/CU48D	1100	36.0	27.0	15.50	12.75
TW4B3621S	TM8E080C16MP11	21.0	CF/CM36D	1125	36.0	27.4	15.50	12.75
TW4B3621S	TM8E080C16MP11	21.0	CF/CM42D	1125	36.0	27.0	15.50	12.75
TW4B3621S	TM8E080C20MP11	21.0	CF/CM/CU36C	1250	36.0	28.2	15.50	12.75
TW4B3621S	TM8E080C20MP11	21.0	CF/CM/CU42C	1250	36.0	28.0	15.50	12.75
TW4B3621S	TM8E080C20MP11	21.0	CF/CM/CU48C	1250	36.0	28.2	15.50	12.75
TW4B3621S	TM8E080C20MP11	21.0	CF/CM/CU48D	1275	36.0	28.4	15.50	12.75
TW4B3621S	TM8E080C20MP11	21.0	CF/CM36D	1275	36.0	28.8	15.50	12.75
TW4B3621S	TM8E080C20MP11	21.0	CF/CM42D	1275	36.0	28.2	15.50	12.75
TW4B3621S	TM8E100B12MP11	17.5	CF/CM/CU36B	1075	36.0	27.0	15.00	12.50
TW4B3621S	TM8E100B12MP11	17.5	CF/CM/CU36C	1100	36.0	27.4	15.00	12.50
TW4B3621S	TM8E100B12MP11	17.5	CF/CM/CU42C	1100	36.0	26.8	15.00	12.50
TW4B3621S	TM8E100B12MP11	17.5	CF/CM/CU48C	1100	36.0	26.8	15.25	12.50

COOLING CAPACITY - With High Efficiency Motor Furnaces¹ (Continued)

UNIT MODEL	FURNACE		COIL MODEL ²	COOLING				
	MODEL	WIDTH		RATED CFM	NET MBH		SEER	EER
					TOTAL	SENS.		
TW4B3621S	TM8E100B12MP11	17.5	CF42B	1050	36.0	26.6	15.00	12.50
TW4B3621S	TM8E100C16MP11	21.0	CF/CM/CU36C	1125	36.0	27.4	15.50	12.75
TW4B3621S	TM8E100C16MP11	21.0	CF/CM/CU42C	1125	36.0	27.0	15.50	12.75
TW4B3621S	TM8E100C16MP11	21.0	CF/CM/CU48C	1125	36.0	27.4	15.50	12.75
TW4B3621S	TM8E100C16MP11	21.0	CF/CM/CU48D	1125	36.0	27.4	15.50	12.75
TW4B3621S	TM8E100C16MP11	21.0	CF/CM36D	1125	36.0	27.4	15.25	12.50
TW4B3621S	TM8E100C16MP11	21.0	CF/CM42D	1125	36.0	27.0	15.50	12.75
TW4B3621S	TM8E100C20MP11	21.0	CF/CM/CU36C	1250	36.0	28.2	15.50	12.75
TW4B3621S	TM8E100C20MP11	21.0	CF/CM/CU42C	1250	36.0	28.0	15.50	12.75
TW4B3621S	TM8E100C20MP11	21.0	CF/CM/CU48C	1250	36.0	28.2	15.50	12.75
TW4B3621S	TM8E100C20MP11	21.0	CF/CM/CU48D	1275	36.0	28.4	15.50	12.75
TW4B3621S	TM8E100C20MP11	21.0	CF/CM36D	1275	36.0	28.8	15.50	12.75
TW4B3621S	TM8E100C20MP11	21.0	CF/CM42D	1275	36.0	28.2	15.50	12.75
TW4B3621S	TM8E120C16MP11	21.0	CF/CM/CU36C	1125	36.0	27.4	15.50	12.75
TW4B3621S	TM8E120C16MP11	21.0	CF/CM/CU42C	1125	36.0	27.0	15.50	12.75
TW4B3621S	TM8E120C16MP11	21.0	CF/CM/CU48C	1125	36.0	27.4	15.50	12.75
TW4B3621S	TM8E120C16MP11	21.0	CF/CM/CU48D	1125	36.0	27.4	15.50	12.75
TW4B3621S	TM8E120C16MP11	21.0	CF/CM36D	1125	36.0	27.4	15.25	12.50
TW4B3621S	TM8E120C16MP11	21.0	CF/CM42D	1125	36.0	27.0	15.50	12.75
TW4B3621S	TM8E120C20MP11	21.0	CF/CM/CU36C	1275	36.0	28.8	15.50	12.75
TW4B3621S	TM8E120C20MP11	21.0	CF/CM/CU42C	1275	36.0	28.2	15.50	12.75
TW4B3621S	TM8E120C20MP11	21.0	CF/CM/CU48C	1300	36.0	28.6	15.50	12.75
TW4B3621S	TM8E120C20MP11	21.0	CF/CM/CU48D	1300	36.0	28.6	15.50	12.75
TW4B3621S	TM8E120C20MP11	21.0	CF/CM36D	1300	36.0	27.8	14.75	12.50
TW4B3621S	TM8E120C20MP11	21.0	CF/CM42D	1300	36.0	28.6	15.25	12.50
TW4B3621S	TM8E130D20MP11	24.5	CF/CM/CU48D	1300	36.0	28.6	15.50	12.75
TW4B3621S	TM8E130D20MP11	24.5	CF/CM36D	1300	36.0	27.8	15.00	12.50
TW4B3621S	TM8E130D20MP11	24.5	CF/CM42D	1300	36.0	28.6	15.50	12.75
TW4B3621S	TM8V080C16MP12C	21.0	CF/CM/CU36C	1050	36.0	26.8	15.50	12.50
TW4B3621S	TM8V080C16MP12C	21.0	CF/CM/CU36D	1050	36.0	26.8	15.50	13.00
TW4B3621S	TM8V080C16MP12C	21.0	CF/CM/CU42C	1050	36.0	26.6	15.50	12.75
TW4B3621S	TM8V080C16MP12C	21.0	CF/CM/CU42D	1050	36.0	26.6	15.75	13.00
TW4B3621S	TM8V080C16MP12C	21.0	CF/CM/CU48C	1050	36.0	26.8	15.50	12.75
TW4B3621S	TM8V080C16MP12C	21.0	CF/CM/CU48D	1050	36.0	26.8	15.50	12.75
TW4B3621S	TM8V100C16MP12C	21.0	CF/CM/CU36C	1050	36.0	26.8	15.50	12.50
TW4B3621S	TM8V100C16MP12C	21.0	CF/CM/CU36D	1050	36.0	26.8	15.50	13.00
TW4B3621S	TM8V100C16MP12C	21.0	CF/CM/CU42C	1050	36.0	26.6	15.50	12.75
TW4B3621S	TM8V100C16MP12C	21.0	CF/CM/CU42D	1050	36.0	26.6	15.75	13.00
TW4B3621S	TM8V100C16MP12C	21.0	CF/CM/CU48C	1050	36.0	26.8	15.50	12.75
TW4B3621S	TM8V100C16MP12C	21.0	CF/CM/CU48D	1050	36.0	26.8	15.50	12.75
TW4B3621S	TM8V100C20MP12C	21.0	CF/CM/CU36C	1150	36.0	27.6	15.50	12.50
TW4B3621S	TM8V100C20MP12C	21.0	CF/CM/CU36D	1150	36.0	27.6	15.75	13.00
TW4B3621S	TM8V100C20MP12C	21.0	CF/CM/CU42C	1150	36.0	27.2	15.50	12.75
TW4B3621S	TM8V100C20MP12C	21.0	CF/CM/CU42D	1150	36.0	27.2	15.75	13.25
TW4B3621S	TM8V100C20MP12C	21.0	CF/CM/CU48C	1150	36.0	27.4	15.75	12.75
TW4B3621S	TM8V100C20MP12C	21.0	CF/CM/CU48D	1150	36.0	27.4	16.00	13.25
TW4B3621S	TM8V120C20MP12C	21.0	CF/CM/CU36C	1150	36.0	27.6	15.50	12.50
TW4B3621S	TM8V120C20MP12C	21.0	CF/CM/CU36D	1150	36.0	27.6	15.75	13.00
TW4B3621S	TM8V120C20MP12C	21.0	CF/CM/CU42C	1150	36.0	27.2	15.50	12.75
TW4B3621S	TM8V120C20MP12C	21.0	CF/CM/CU42D	1150	36.0	27.2	15.75	13.25
TW4B3621S	TM8V120C20MP12C	21.0	CF/CM/CU48C	1150	36.0	27.4	15.75	12.75
TW4B3621S	TM8V120C20MP12C	21.0	CF/CM/CU48D	1150	36.0	27.4	16.00	13.25
TW4B3621S	TM8X060A12MP11	14.5	CF/CM36A	1075	36.0	27.0	14.75	12.50

COOLING CAPACITY - With High Efficiency Motor Furnaces¹ (Continued)

UNIT MODEL	FURNACE		COIL MODEL ²	COOLING				
	MODEL	WIDTH		RATED CFM	NET MBH		SEER	EER
					TOTAL	SENS.		
TW4B3621S	TM8X080B12MP11	17.5	CF/CM/CU36B	975	35.8	26.2	15.25	12.50
TW4B3621S	TM8X080B12MP11	17.5	CF42B	1150	36.0	27.2	15.00	12.50
TW4B3621S	TM8X080C16MP11	21.0	CF/CM/CU36C	1150	36.0	27.8	15.25	12.75
TW4B3621S	TM8X080C16MP11	21.0	CF/CM/CU36D	975	36.0	26.4	15.50	12.75
TW4B3621S	TM8X080C16MP11	21.0	CF/CM/CU42C	1150	36.0	27.2	15.25	12.75
TW4B3621S	TM8X080C16MP11	21.0	CF/CM/CU42D	975	36.0	25.8	15.50	12.75
TW4B3621S	TM8X080C16MP11	21.0	CF/CM/CU48C	1150	36.0	27.4	15.50	12.75
TW4B3621S	TM8X080C16MP11	21.0	CF/CM/CU48D	975	36.0	26.2	15.75	13.00
TW4B3621S	TM8X100C16MP11	21.0	CF/CM/CU36C	1150	36.0	27.8	15.25	12.75
TW4B3621S	TM8X100C16MP11	21.0	CF/CM/CU36D	975	36.0	26.4	15.50	12.75
TW4B3621S	TM8X100C16MP11	21.0	CF/CM/CU42C	1150	36.0	27.2	15.25	12.75
TW4B3621S	TM8X100C16MP11	21.0	CF/CM/CU42D	975	36.0	25.8	15.50	12.75
TW4B3621S	TM8X100C16MP11	21.0	CF/CM/CU48C	1150	36.0	27.4	15.50	12.75
TW4B3621S	TM8X100C16MP11	21.0	CF/CM/CU48D	975	36.0	26.2	15.75	13.00
TW4B3621S	TM8X100C20MP11	21.0	CF/CM/CU36C	1000	36.0	26.4	15.75	12.75
TW4B3621S	TM8X100C20MP11	21.0	CF/CM/CU36D	1000	36.0	26.4	15.75	12.75
TW4B3621S	TM8X100C20MP11	21.0	CF/CM/CU42C	1000	36.0	26.0	15.75	12.75
TW4B3621S	TM8X100C20MP11	21.0	CF/CM/CU42D	1000	36.0	26.0	15.50	12.75
TW4B3621S	TM8X100C20MP11	21.0	CF/CM/CU48C	1000	36.0	26.2	15.75	12.75
TW4B3621S	TM8X100C20MP11	21.0	CF/CM/CU48D	1000	36.0	26.2	15.75	12.75
TW4B3621S	TM8X120C20MP11	21.0	CF/CM/CU36C	1000	36.0	26.4	15.75	12.75
TW4B3621S	TM8X120C20MP11	21.0	CF/CM/CU36D	1000	36.0	26.4	15.75	12.75
TW4B3621S	TM8X120C20MP11	21.0	CF/CM/CU42C	1000	36.0	26.0	15.75	12.75
TW4B3621S	TM8X120C20MP11	21.0	CF/CM/CU42D	1000	36.0	26.0	15.50	12.75
TW4B3621S	TM8X120C20MP11	21.0	CF/CM/CU48C	1000	36.0	26.2	15.75	12.75
TW4B3621S	TM8X120C20MP11	21.0	CF/CM/CU48D	1000	36.0	26.2	15.75	12.75
TW4B3621S	TM8Y060A12MP11	14.5	CF/CM36A	1075	36.0	27.0	14.75	12.50
TW4B3621S	TM8Y080B12MP11	17.5	CF/CM/CU36B	975	35.8	26.2	15.25	12.50
TW4B3621S	TM8Y080B12MP11	17.5	CF42B	1150	36.0	27.2	15.00	12.50
TW4B3621S	TM8Y080C16MP11	21.0	CF/CM/CU36C	1150	36.0	27.8	15.25	12.75
TW4B3621S	TM8Y080C16MP11	21.0	CF/CM/CU36D	975	36.0	26.4	15.50	12.75
TW4B3621S	TM8Y080C16MP11	21.0	CF/CM/CU42C	1150	36.0	27.2	15.25	12.75
TW4B3621S	TM8Y080C16MP11	21.0	CF/CM/CU42D	975	36.0	25.8	15.50	12.75
TW4B3621S	TM8Y080C16MP11	21.0	CF/CM/CU48C	1150	36.0	27.4	15.50	12.75
TW4B3621S	TM8Y080C16MP11	21.0	CF/CM/CU48D	975	36.0	26.2	15.75	13.00
TW4B3621S	TM8Y100C16MP11	21.0	CF/CM/CU36C	1150	36.0	27.8	15.25	12.75
TW4B3621S	TM8Y100C16MP11	21.0	CF/CM/CU36D	975	36.0	26.4	15.50	12.75
TW4B3621S	TM8Y100C16MP11	21.0	CF/CM/CU42C	1150	36.0	27.2	15.25	12.75
TW4B3621S	TM8Y100C16MP11	21.0	CF/CM/CU42D	975	36.0	25.8	15.50	12.75
TW4B3621S	TM8Y100C16MP11	21.0	CF/CM/CU48C	1150	36.0	27.4	15.50	12.75
TW4B3621S	TM8Y100C16MP11	21.0	CF/CM/CU48D	975	36.0	26.2	15.75	13.00
TW4B3621S	TM8Y100C20MP11	21.0	CF/CM/CU36C	1000	36.0	26.4	15.75	12.75
TW4B3621S	TM8Y100C20MP11	21.0	CF/CM/CU36D	1000	36.0	26.4	15.75	12.75
TW4B3621S	TM8Y100C20MP11	21.0	CF/CM/CU42C	1000	36.0	26.0	15.75	12.75
TW4B3621S	TM8Y100C20MP11	21.0	CF/CM/CU42D	1000	36.0	26.0	15.50	12.75
TW4B3621S	TM8Y100C20MP11	21.0	CF/CM/CU48C	1000	36.0	26.2	15.75	12.75
TW4B3621S	TM8Y100C20MP11	21.0	CF/CM/CU48D	1000	36.0	26.2	15.75	12.75
TW4B3621S	TM8Y120C20MP11	21.0	CF/CM/CU36C	1000	36.0	26.4	15.75	12.75
TW4B3621S	TM8Y120C20MP11	21.0	CF/CM/CU36D	1000	36.0	26.4	15.75	12.75
TW4B3621S	TM8Y120C20MP11	21.0	CF/CM/CU42C	1000	36.0	26.0	15.75	12.75
TW4B3621S	TM8Y120C20MP11	21.0	CF/CM/CU42D	1000	36.0	26.0	15.50	12.75
TW4B3621S	TM8Y120C20MP11	21.0	CF/CM/CU48C	1000	36.0	26.2	15.75	12.75
TW4B3621S	TM8Y120C20MP11	21.0	CF/CM/CU48D	1000	36.0	26.2	15.75	12.75

COOLING CAPACITY - With High Efficiency Motor Furnaces¹ (Continued)

UNIT MODEL	FURNACE		COIL MODEL ²	COOLING				
	MODEL	WIDTH		RATED CFM	NET MBH		SEER	EER
					TOTAL	SENS.		
TW4B3621S	TM9E060A10MP12	14.5	CF/CM/CU36B	1025	35.8	26.6	14.25	12.25
TW4B3621S	TM9E060A10MP12	14.5	CF42B	1025	36.0	26.0	14.25	12.25
TW4B3621S	TM9E060B12MP11	17.5	CF/CM/CU36B	1100	36.0	27.2	14.50	12.25
TW4B3621S	TM9E060B12MP11	17.5	CF/CM/CU36C	975	35.6	26.0	15.00	12.50
TW4B3621S	TM9E060B12MP11	17.5	CF/CM/CU42C	975	36.0	25.8	15.00	12.50
TW4B3621S	TM9E060B12MP11	17.5	CF/CM/CU48C	975	36.0	26.2	15.00	12.50
TW4B3621S	TM9E060B12MP11	17.5	CF42B	1100	36.0	26.8	14.50	12.25
TW4B3621S	TM9E060B12MP12	17.5	CF/CM/CU36B	1075	36.0	27.0	14.50	12.25
TW4B3621S	TM9E060B12MP12	17.5	CF/CM/CU36C	1100	36.0	27.2	14.50	12.25
TW4B3621S	TM9E060B12MP12	17.5	CF/CM/CU42C	1100	36.0	26.8	14.50	12.25
TW4B3621S	TM9E060B12MP12	17.5	CF/CM/CU48C	1100	36.0	27.0	14.75	12.25
TW4B3621S	TM9E060B12MP12	17.5	CF42B	1050	36.0	26.6	14.50	12.25
TW4B3621S	TM9E080B12MP11	17.5	CF/CM/CU36B	975	35.8	26.2	15.25	12.50
TW4B3621S	TM9E080B12MP11	17.5	CF42B	975	36.0	25.8	15.00	12.50
TW4B3621S	TM9E080B12MP12	17.5	CF/CM/CU36B	1050	36.0	26.6	15.00	12.50
TW4B3621S	TM9E080B12MP12	17.5	CF/CM/CU36C	1075	36.0	27.0	15.00	12.50
TW4B3621S	TM9E080B12MP12	17.5	CF/CM/CU42C	1075	36.0	26.6	15.00	12.50
TW4B3621S	TM9E080B12MP12	17.5	CF/CM/CU48C	1075	36.0	27.0	15.00	12.50
TW4B3621S	TM9E080B12MP12	17.5	CF42B	1025	36.0	26.0	15.00	12.50
TW4B3621S	TM9E080C16MP11	21.0	CF/CM/CU36C	975	35.6	26.0	15.25	12.75
TW4B3621S	TM9E080C16MP11	21.0	CF/CM/CU42C	975	36.0	25.8	15.25	12.75
TW4B3621S	TM9E080C16MP11	21.0	CF/CM/CU48C	975	36.0	26.2	15.50	12.75
TW4B3621S	TM9E080C16MP11	21.0	CF/CM/CU48D	975	36.0	26.2	15.50	12.75
TW4B3621S	TM9E080C16MP11	21.0	CF/CM36D	975	35.6	26.0	15.25	12.75
TW4B3621S	TM9E080C16MP11	21.0	CF/CM42D	975	36.0	25.8	15.25	12.75
TW4B3621S	TM9E080C16MP12	21.0	CF/CM/CU36C	1075	36.0	27.0	15.25	12.50
TW4B3621S	TM9E080C16MP12	21.0	CF/CM/CU42C	1075	36.0	26.6	15.25	12.50
TW4B3621S	TM9E080C16MP12	21.0	CF/CM/CU48C	1100	36.0	27.0	15.50	12.75
TW4B3621S	TM9E080C16MP12	21.0	CF/CM/CU48D	1100	36.0	27.0	15.25	12.50
TW4B3621S	TM9E080C16MP12	21.0	CF/CM36D	1100	36.0	27.2	15.25	12.50
TW4B3621S	TM9E080C16MP12	21.0	CF/CM42D	1100	36.0	26.8	15.25	12.50
TW4B3621S	TM9E080C20MP12	21.0	CF/CM/CU36C	1225	36.0	28.6	15.50	12.75
TW4B3621S	TM9E080C20MP12	21.0	CF/CM/CU42C	1225	36.0	27.8	15.50	12.75
TW4B3621S	TM9E080C20MP12	21.0	CF/CM/CU48C	1225	36.0	28.2	15.50	12.75
TW4B3621S	TM9E080C20MP12	21.0	CF/CM/CU48D	1250	36.0	28.2	15.50	12.75
TW4B3621S	TM9E080C20MP12	21.0	CF/CM36D	1250	36.0	28.2	15.50	12.75
TW4B3621S	TM9E080C20MP12	21.0	CF/CM42D	1250	36.0	28.0	15.50	12.75
TW4B3621S	TM9E100C16MP11	21.0	CF/CM/CU36C	975	36.0	26.4	15.50	12.75
TW4B3621S	TM9E100C16MP11	21.0	CF/CM/CU36D	1000	36.0	26.2	15.50	12.75
TW4B3621S	TM9E100C16MP11	21.0	CF/CM/CU42C	975	36.0	25.8	15.50	12.75
TW4B3621S	TM9E100C16MP11	21.0	CF/CM/CU42D	1000	36.0	26.0	15.50	12.75
TW4B3621S	TM9E100C16MP11	21.0	CF/CM/CU48C	1000	36.0	26.4	15.50	12.75
TW4B3621S	TM9E100C16MP11	21.0	CF/CM/CU48D	1000	36.0	26.4	15.75	12.75
TW4B3621S	TM9E100C16MP12	21.0	CF/CM/CU36C	1075	36.0	27.0	15.50	12.75
TW4B3621S	TM9E100C16MP12	21.0	CF/CM/CU42C	1075	36.0	26.6	15.50	12.75
TW4B3621S	TM9E100C16MP12	21.0	CF/CM/CU48C	1075	36.0	27.0	15.50	12.75
TW4B3621S	TM9E100C16MP12	21.0	CF/CM/CU48D	1075	36.0	27.0	15.50	12.75
TW4B3621S	TM9E100C16MP12	21.0	CF/CM36D	1075	36.0	27.0	15.25	12.50
TW4B3621S	TM9E100C16MP12	21.0	CF/CM42D	1075	36.0	26.6	15.25	12.50
TW4B3621S	TM9E100C20MP11	21.0	CF/CM/CU36C	1175	36.0	27.6	15.25	12.75
TW4B3621S	TM9E100C20MP11	21.0	CF/CM/CU36D	1200	36.0	28.4	15.25	12.50
TW4B3621S	TM9E100C20MP11	21.0	CF/CM/CU42C	1175	36.0	27.4	15.50	12.75
TW4B3621S	TM9E100C20MP11	21.0	CF/CM/CU42D	1200	36.0	27.6	15.50	12.75

COOLING CAPACITY - With High Efficiency Motor Furnaces¹ (Continued)

UNIT MODEL	FURNACE		COIL MODEL ²	COOLING				
	MODEL	WIDTH		RATED CFM	NET MBH		SEER	EER
					TOTAL	SENS.		
TW4B3621S	TM9E100C20MP11	21.0	CF/CM/CU48C	1175	36.0	27.6	15.75	13.00
TW4B3621S	TM9E100C20MP11	21.0	CF/CM/CU48D	1200	36.0	27.8	15.75	13.00
TW4B3621S	TM9E100C20MP12	21.0	CF/CM/CU36C	1200	36.0	28.4	15.50	12.75
TW4B3621S	TM9E100C20MP12	21.0	CF/CM/CU42C	1225	36.0	27.8	15.50	12.75
TW4B3621S	TM9E100C20MP12	21.0	CF/CM/CU48C	1225	36.0	28.2	15.50	12.75
TW4B3621S	TM9E100C20MP12	21.0	CF/CM/CU48D	1225	36.0	28.2	15.50	12.75
TW4B3621S	TM9E100C20MP12	21.0	CF/CM36D	1225	36.0	28.6	15.50	12.75
TW4B3621S	TM9E100C20MP12	21.0	CF/CM42D	1225	36.0	27.8	15.50	12.75
TW4B3621S	TM9E120D20MP11	24.5	CF/CM/CU36D	1250	36.0	28.2	15.50	12.75
TW4B3621S	TM9E120D20MP11	24.5	CF/CM/CU42D	1250	36.0	28.0	15.50	12.75
TW4B3621S	TM9E120D20MP11	24.5	CF/CM/CU48D	1250	36.0	28.2	15.75	13.00
TW4B3621S	TM9E120D20MP12	24.5	CF/CM/CU48D	1250	36.0	28.2	15.50	12.75
TW4B3621S	TM9E120D20MP12	24.5	CF/CM36D	1250	36.0	28.2	15.50	12.75
TW4B3621S	TM9E120D20MP12	24.5	CF/CM42D	1250	36.0	28.0	15.50	12.75
TW4B3621S	TM9V060B12MP11C	17.5	CF/CM/CU36B	1000	35.8	26.0	14.75	12.50
TW4B3621S	TM9V060B12MP11C	17.5	CF/CM/CU36C	1000	36.0	26.4	14.75	12.50
TW4B3621S	TM9V060B12MP11C	17.5	CF/CM/CU42C	1000	36.0	26.0	14.75	12.50
TW4B3621S	TM9V060B12MP11C	17.5	CF/CM/CU48C	1000	36.0	26.2	14.75	12.50
TW4B3621S	TM9V060B12MP11C	17.5	CF42B	1000	36.0	26.0	14.75	12.50
TW4B3621S	TM9V060B12MP12C	17.5	CF/CM/CU36B	1000	35.8	26.0	14.75	12.50
TW4B3621S	TM9V060B12MP12C	17.5	CF/CM/CU36C	1000	36.0	26.4	14.75	12.50
TW4B3621S	TM9V060B12MP12C	17.5	CF/CM/CU42C	1000	36.0	26.0	14.75	12.50
TW4B3621S	TM9V060B12MP12C	17.5	CF/CM/CU48C	1000	36.0	26.2	14.75	12.50
TW4B3621S	TM9V060B12MP12C	17.5	CF42B	1000	36.0	26.0	14.75	12.50
TW4B3621S	TM9V080B12MP12C	17.5	CF/CM/CU36B	975	35.8	26.2	15.00	12.50
TW4B3621S	TM9V080B12MP12C	17.5	CF42B	975	36.0	25.8	15.25	12.50
TW4B3621S	TM9V080C16MP11C	21.0	CF/CM/CU36C	1025	36.0	26.6	15.25	12.50
TW4B3621S	TM9V080C16MP11C	21.0	CF/CM/CU42C	1025	36.0	26.0	15.50	12.75
TW4B3621S	TM9V080C16MP11C	21.0	CF/CM/CU48C	1025	36.0	26.4	15.50	12.75
TW4B3621S	TM9V080C16MP11C	21.0	CF/CM/CU48D	1025	36.0	26.4	15.50	12.75
TW4B3621S	TM9V080C16MP11C	21.0	CF/CM36D	1025	36.0	26.6	15.50	12.75
TW4B3621S	TM9V080C16MP11C	21.0	CF/CM42D	1025	36.0	26.0	15.50	12.75
TW4B3621S	TM9V080C16MP12C	21.0	CF/CM/CU36C	1025	36.0	26.6	15.25	12.50
TW4B3621S	TM9V080C16MP12C	21.0	CF/CM/CU42C	1025	36.0	26.0	15.50	12.75
TW4B3621S	TM9V080C16MP12C	21.0	CF/CM/CU48C	1025	36.0	26.4	15.50	12.75
TW4B3621S	TM9V080C16MP12C	21.0	CF/CM/CU48D	1025	36.0	26.4	15.50	12.75
TW4B3621S	TM9V080C16MP12C	21.0	CF/CM36D	1025	36.0	26.6	15.50	12.75
TW4B3621S	TM9V080C16MP12C	21.0	CF/CM42D	1025	36.0	26.0	15.50	12.75
TW4B3621S	TM9V100C16MP12C	21.0	CF/CM/CU36C	1000	36.0	26.2	15.50	12.50
TW4B3621S	TM9V100C16MP12C	21.0	CF/CM/CU36D	1075	36.0	27.0	15.50	13.00
TW4B3621S	TM9V100C16MP12C	21.0	CF/CM/CU42C	1000	36.0	26.0	15.50	12.75
TW4B3621S	TM9V100C16MP12C	21.0	CF/CM/CU42D	1050	36.0	26.6	15.75	13.00
TW4B3621S	TM9V100C16MP12C	21.0	CF/CM/CU48C	1075	36.0	27.0	15.75	12.75
TW4B3621S	TM9V100C16MP12C	21.0	CF/CM/CU48D	1075	36.0	27.0	15.50	12.75
TW4B3621S	TM9V100C20MP12C	21.0	CF/CM/CU36C	1100	36.0	27.2	15.25	12.50
TW4B3621S	TM9V100C20MP12C	21.0	CF/CM/CU36D	1100	36.0	27.2	15.50	13.00
TW4B3621S	TM9V100C20MP12C	21.0	CF/CM/CU42C	1100	36.0	26.8	15.25	12.75
TW4B3621S	TM9V100C20MP12C	21.0	CF/CM/CU42D	1100	36.0	26.8	15.50	13.00
TW4B3621S	TM9V100C20MP12C	21.0	CF/CM/CU48C	1100	36.0	27.0	15.50	12.50
TW4B3621S	TM9V100C20MP12C	21.0	CF/CM/CU48D	1100	36.0	27.0	15.50	12.50
TW4B3621S	TM9V120D20MP12C	24.5	CF/CM/CU36D	1050	36.0	26.8	15.75	13.00
TW4B3621S	TM9V120D20MP12C	24.5	CF/CM/CU42D	1050	36.0	26.4	15.75	12.75
TW4B3621S	TM9V120D20MP12C	24.5	CF/CM/CU48D	1050	36.0	26.8	15.75	12.75

COOLING CAPACITY - With High Efficiency Motor Furnaces¹ (Continued)

UNIT MODEL	FURNACE		COIL MODEL ²	COOLING				
	MODEL	WIDTH		RATED CFM	NET MBH		SEER	EER
					TOTAL	SENS.		
TW4B3621S	TM9Y060B12MP11	17.5	CF/CM/CU36B	1100	36.0	27.2	14.50	12.25
TW4B3621S	TM9Y060B12MP11	17.5	CF/CM/CU36C	975	35.6	26.0	15.00	12.50
TW4B3621S	TM9Y060B12MP11	17.5	CF/CM/CU42C	975	36.0	25.8	15.00	12.50
TW4B3621S	TM9Y060B12MP11	17.5	CF/CM/CU48C	975	36.0	26.2	15.00	12.50
TW4B3621S	TM9Y060B12MP11	17.5	CF42B	1100	36.0	26.8	14.50	12.25
TW4B3621S	TM9Y080B12MP11	17.5	CF/CM/CU36B	975	35.8	26.2	15.25	12.50
TW4B3621S	TM9Y080B12MP11	17.5	CF42B	975	36.0	25.8	15.00	12.50
TW4B3621S	TM9Y080C16MP11	21.0	CF/CM/CU36C	975	35.6	26.0	15.25	12.75
TW4B3621S	TM9Y080C16MP11	21.0	CF/CM/CU42C	975	36.0	25.8	15.25	12.75
TW4B3621S	TM9Y080C16MP11	21.0	CF/CM/CU48C	975	36.0	26.2	15.50	12.75
TW4B3621S	TM9Y080C16MP11	21.0	CF/CM/CU48D	975	36.0	26.2	15.50	12.75
TW4B3621S	TM9Y080C16MP11	21.0	CF/CM36D	975	35.6	26.0	15.25	12.75
TW4B3621S	TM9Y080C16MP11	21.0	CF/CM42D	975	36.0	25.8	15.25	12.75
TW4B3621S	TM9Y100C16MP11	21.0	CF/CM/CU36C	975	36.0	26.4	15.50	12.75
TW4B3621S	TM9Y100C16MP11	21.0	CF/CM/CU36D	1000	36.0	26.2	15.50	12.75
TW4B3621S	TM9Y100C16MP11	21.0	CF/CM/CU42C	975	36.0	25.8	15.50	12.75
TW4B3621S	TM9Y100C16MP11	21.0	CF/CM/CU42D	1000	36.0	26.0	15.50	12.75
TW4B3621S	TM9Y100C16MP11	21.0	CF/CM/CU48C	1000	36.0	26.4	15.50	12.75
TW4B3621S	TM9Y100C16MP11	21.0	CF/CM/CU48D	1000	36.0	26.4	15.75	12.75
TW4B3621S	TM9Y100C20MP11	21.0	CF/CM/CU36C	1175	36.0	27.6	15.25	12.75
TW4B3621S	TM9Y100C20MP11	21.0	CF/CM/CU36D	1200	36.0	28.4	15.25	12.50
TW4B3621S	TM9Y100C20MP11	21.0	CF/CM/CU42C	1175	36.0	27.4	15.50	12.75
TW4B3621S	TM9Y100C20MP11	21.0	CF/CM/CU42D	1200	36.0	27.6	15.50	12.75
TW4B3621S	TM9Y100C20MP11	21.0	CF/CM/CU48C	1175	36.0	27.6	15.75	13.00
TW4B3621S	TM9Y100C20MP11	21.0	CF/CM/CU48D	1200	36.0	27.8	15.75	13.00
TW4B3621S	TM9Y120D20MP11	24.5	CF/CM/CU36D	1250	36.0	28.2	15.50	12.75
TW4B3621S	TM9Y120D20MP11	24.5	CF/CM/CU42D	1250	36.0	28.0	15.50	12.75
TW4B3621S	TM9Y120D20MP11	24.5	CF/CM/CU48D	1250	36.0	28.2	15.75	13.00
TW4B3621S	TMLV080C16MP12C	21.0	CF/CM/CU36C	1050	36.0	26.8	15.50	12.50
TW4B3621S	TMLV080C16MP12C	21.0	CF/CM/CU36D	1050	36.0	26.8	15.50	13.00
TW4B3621S	TMLV080C16MP12C	21.0	CF/CM/CU42C	1050	36.0	26.6	15.50	12.75
TW4B3621S	TMLV080C16MP12C	21.0	CF/CM/CU42D	1050	36.0	26.6	15.75	13.00
TW4B3621S	TMLV080C16MP12C	21.0	CF/CM/CU48C	1050	36.0	26.8	15.50	12.75
TW4B3621S	TMLV080C16MP12C	21.0	CF/CM/CU48D	1050	36.0	26.8	15.50	12.75
TW4B3621S	TMLV100C16MP12C	21.0	CF/CM/CU36C	1050	36.0	26.8	15.50	12.50
TW4B3621S	TMLV100C16MP12C	21.0	CF/CM/CU36D	1050	36.0	26.8	15.50	13.00
TW4B3621S	TMLV100C16MP12C	21.0	CF/CM/CU42C	1050	36.0	26.6	15.50	12.75
TW4B3621S	TMLV100C16MP12C	21.0	CF/CM/CU42D	1050	36.0	26.6	15.75	13.00
TW4B3621S	TMLV100C16MP12C	21.0	CF/CM/CU48C	1050	36.0	26.8	15.50	12.75
TW4B3621S	TMLV100C16MP12C	21.0	CF/CM/CU48D	1050	36.0	26.8	15.50	12.75
TW4B3621S	TMLV100C20MP12C	21.0	CF/CM/CU36C	1150	36.0	27.6	15.50	12.50
TW4B3621S	TMLV100C20MP12C	21.0	CF/CM/CU36D	1150	36.0	27.6	15.75	13.00
TW4B3621S	TMLV100C20MP12C	21.0	CF/CM/CU42C	1150	36.0	27.2	15.50	12.75
TW4B3621S	TMLV100C20MP12C	21.0	CF/CM/CU42D	1150	36.0	27.2	15.75	13.25
TW4B3621S	TMLV100C20MP12C	21.0	CF/CM/CU48C	1150	36.0	27.4	15.75	12.75
TW4B3621S	TMLV100C20MP12C	21.0	CF/CM/CU48D	1150	36.0	27.4	16.00	13.25
TW4B3621S	TMLV120C20MP12C	21.0	CF/CM/CU36C	1150	36.0	27.6	15.50	12.50
TW4B3621S	TMLV120C20MP12C	21.0	CF/CM/CU36D	1150	36.0	27.6	15.75	13.00
TW4B3621S	TMLV120C20MP12C	21.0	CF/CM/CU42C	1150	36.0	27.2	15.50	12.75
TW4B3621S	TMLV120C20MP12C	21.0	CF/CM/CU42D	1150	36.0	27.2	15.75	13.25
TW4B3621S	TMLV120C20MP12C	21.0	CF/CM/CU48C	1150	36.0	27.4	15.75	12.75
TW4B3621S	TMLV120C20MP12C	21.0	CF/CM/CU48D	1150	36.0	27.4	16.00	13.25
TW4B3621S	TMLX060A12MP11	14.5	CF/CM36A	1075	36.0	27.0	14.75	12.50

COOLING CAPACITY - With High Efficiency Motor Furnaces¹ (Continued)

UNIT MODEL	FURNACE		COIL MODEL ²	COOLING				
	MODEL	WIDTH		RATED CFM	NET MBH		SEER	EER
					TOTAL	SENS.		
TW4B3621S	TMLX080B12MP11	17.5	CF/CM/CU36B	975	35.8	26.2	15.25	12.50
TW4B3621S	TMLX080B12MP11	17.5	CF42B	1150	36.0	27.2	15.00	12.50
TW4B3621S	TMLX080C16MP11	21.0	CF/CM/CU36C	1150	36.0	27.8	15.25	12.75
TW4B3621S	TMLX080C16MP11	21.0	CF/CM/CU36D	975	36.0	26.4	15.50	12.75
TW4B3621S	TMLX080C16MP11	21.0	CF/CM/CU42C	1150	36.0	27.2	15.25	12.75
TW4B3621S	TMLX080C16MP11	21.0	CF/CM/CU42D	975	36.0	25.8	15.50	12.75
TW4B3621S	TMLX080C16MP11	21.0	CF/CM/CU48C	1150	36.0	27.4	15.50	12.75
TW4B3621S	TMLX080C16MP11	21.0	CF/CM/CU48D	975	36.0	26.2	15.75	13.00
TW4B3621S	TMLX100C16MP11	21.0	CF/CM/CU36C	1150	36.0	27.8	15.25	12.75
TW4B3621S	TMLX100C16MP11	21.0	CF/CM/CU36D	975	36.0	26.4	15.50	12.75
TW4B3621S	TMLX100C16MP11	21.0	CF/CM/CU42C	1150	36.0	27.2	15.25	12.75
TW4B3621S	TMLX100C16MP11	21.0	CF/CM/CU42D	975	36.0	25.8	15.50	12.75
TW4B3621S	TMLX100C16MP11	21.0	CF/CM/CU48C	1150	36.0	27.4	15.50	12.75
TW4B3621S	TMLX100C16MP11	21.0	CF/CM/CU48D	975	36.0	26.2	15.75	13.00
TW4B3621S	TMLX100C20MP11	21.0	CF/CM/CU36C	1000	36.0	26.4	15.75	12.75
TW4B3621S	TMLX100C20MP11	21.0	CF/CM/CU36D	1000	36.0	26.4	15.75	12.75
TW4B3621S	TMLX100C20MP11	21.0	CF/CM/CU42C	1000	36.0	26.0	15.75	12.75
TW4B3621S	TMLX100C20MP11	21.0	CF/CM/CU42D	1000	36.0	26.0	15.50	12.75
TW4B3621S	TMLX100C20MP11	21.0	CF/CM/CU48C	1000	36.0	26.2	15.75	12.75
TW4B3621S	TMLX100C20MP11	21.0	CF/CM/CU48D	1000	36.0	26.2	15.75	12.75
TW4B3621S	TMLX120C20MP11	21.0	CF/CM/CU36C	1000	36.0	26.4	15.75	12.75
TW4B3621S	TMLX120C20MP11	21.0	CF/CM/CU36D	1000	36.0	26.4	15.75	12.75
TW4B3621S	TMLX120C20MP11	21.0	CF/CM/CU42C	1000	36.0	26.0	15.75	12.75
TW4B3621S	TMLX120C20MP11	21.0	CF/CM/CU42D	1000	36.0	26.0	15.50	12.75
TW4B3621S	TMLX120C20MP11	21.0	CF/CM/CU48C	1000	36.0	26.2	15.75	12.75
TW4B3621S	TMLX120C20MP11	21.0	CF/CM/CU48D	1000	36.0	26.2	15.75	12.75
TW4B3621S	TP9C060B12MP13C	17.5	CF/CM/CU36B	1000	35.8	26.0	14.75	12.50
TW4B3621S	TP9C060B12MP13C	17.5	CF/CM/CU36C	1000	36.0	26.4	14.75	12.50
TW4B3621S	TP9C060B12MP13C	17.5	CF/CM/CU42C	1000	36.0	26.0	14.75	12.50
TW4B3621S	TP9C060B12MP13C	17.5	CF/CM/CU48C	1000	36.0	26.2	14.75	12.50
TW4B3621S	TP9C060B12MP13C	17.5	CF42B	1000	36.0	26.0	14.75	12.50
TW4B3621S	TP9C080B12MP13C	17.5	CF/CM/CU36B	975	35.8	26.2	15.00	12.50
TW4B3621S	TP9C080B12MP13C	17.5	CF42B	975	36.0	25.8	15.25	12.50
TW4B3621S	TP9C080C16MP13C	21.0	CF/CM/CU36C	1025	36.0	26.6	15.25	12.50
TW4B3621S	TP9C080C16MP13C	21.0	CF/CM/CU42C	1025	36.0	26.0	15.50	12.75
TW4B3621S	TP9C080C16MP13C	21.0	CF/CM/CU48C	1025	36.0	26.4	15.50	12.75
TW4B3621S	TP9C080C16MP13C	21.0	CF/CM/CU48D	1025	36.0	26.4	15.50	12.75
TW4B3621S	TP9C080C16MP13C	21.0	CF/CM36D	1025	36.0	26.6	15.50	12.75
TW4B3621S	TP9C080C16MP13C	21.0	CF/CM42D	1025	36.0	26.0	15.50	12.75
TW4B3621S	TP9C100C16MP13C	21.0	CF/CM/CU36C	1000	36.0	26.2	15.50	12.50
TW4B3621S	TP9C100C16MP13C	21.0	CF/CM/CU36D	1075	36.0	27.0	15.50	13.00
TW4B3621S	TP9C100C16MP13C	21.0	CF/CM/CU42C	1000	36.0	26.0	15.50	12.75
TW4B3621S	TP9C100C16MP13C	21.0	CF/CM/CU42D	1050	36.0	26.6	15.75	13.00
TW4B3621S	TP9C100C16MP13C	21.0	CF/CM/CU48C	1075	36.0	27.0	15.75	12.75
TW4B3621S	TP9C100C16MP13C	21.0	CF/CM/CU48D	1075	36.0	27.0	15.50	12.75
TW4B3621S	TP9C100C20MP13C	21.0	CF/CM/CU36C	1100	36.0	27.2	15.25	12.50
TW4B3621S	TP9C100C20MP13C	21.0	CF/CM/CU36D	1100	36.0	27.2	15.50	13.00
TW4B3621S	TP9C100C20MP13C	21.0	CF/CM/CU42C	1100	36.0	26.8	15.25	12.75
TW4B3621S	TP9C100C20MP13C	21.0	CF/CM/CU42D	1100	36.0	26.8	15.50	13.00
TW4B3621S	TP9C100C20MP13C	21.0	CF/CM/CU48C	1100	36.0	27.0	15.50	12.50
TW4B3621S	TP9C100C20MP13C	21.0	CF/CM/CU48D	1100	36.0	27.0	15.50	12.50
TW4B3621S	TP9C120D20MP13C	24.5	CF/CM/CU36D	1050	36.0	26.8	15.75	13.00
TW4B3621S	TP9C120D20MP13C	24.5	CF/CM/CU42D	1050	36.0	26.4	15.75	12.75

COOLING CAPACITY - With High Efficiency Motor Furnaces¹ (Continued)

UNIT MODEL	FURNACE		COIL MODEL ²	COOLING				
	MODEL	WIDTH		RATED CFM	NET MBH		SEER	EER
					TOTAL	SENS.		
TW4B3621S	TP9C120D20MP13C	24.5	CF/CM/CU48D	1050	36.0	26.8	15.75	12.75
TW4B3621S	TPLC080C16MP13C	21.0	CF/CM/CU36C	1050	36.0	26.8	15.50	12.50
TW4B3621S	TPLC080C16MP13C	21.0	CF/CM/CU36D	1050	36.0	26.8	15.50	13.00
TW4B3621S	TPLC080C16MP13C	21.0	CF/CM/CU42C	1050	36.0	26.6	15.50	12.75
TW4B3621S	TPLC080C16MP13C	21.0	CF/CM/CU42D	1050	36.0	26.6	15.75	13.00
TW4B3621S	TPLC080C16MP13C	21.0	CF/CM/CU48C	1050	36.0	26.8	15.50	12.75
TW4B3621S	TPLC080C16MP13C	21.0	CF/CM/CU48D	1050	36.0	26.8	15.50	12.75
TW4B3621S	TPLC100C16MP13C	21.0	CF/CM/CU36C	1050	36.0	26.8	15.50	12.50
TW4B3621S	TPLC100C16MP13C	21.0	CF/CM/CU36D	1050	36.0	26.8	15.50	13.00
TW4B3621S	TPLC100C16MP13C	21.0	CF/CM/CU42C	1050	36.0	26.6	15.50	12.75
TW4B3621S	TPLC100C16MP13C	21.0	CF/CM/CU42D	1050	36.0	26.6	15.75	13.00
TW4B3621S	TPLC100C16MP13C	21.0	CF/CM/CU48C	1050	36.0	26.8	15.50	12.75
TW4B3621S	TPLC100C16MP13C	21.0	CF/CM/CU48D	1050	36.0	26.8	15.50	12.75
TW4B3621S	TPLC100C20MP13C	21.0	CF/CM/CU36C	1150	36.0	27.6	15.50	12.50
TW4B3621S	TPLC100C20MP13C	21.0	CF/CM/CU36D	1150	36.0	27.6	15.75	13.00
TW4B3621S	TPLC100C20MP13C	21.0	CF/CM/CU42C	1150	36.0	27.2	15.50	12.75
TW4B3621S	TPLC100C20MP13C	21.0	CF/CM/CU42D	1150	36.0	27.2	15.75	13.25
TW4B3621S	TPLC100C20MP13C	21.0	CF/CM/CU48C	1150	36.0	27.4	15.75	12.75
TW4B3621S	TPLC100C20MP13C	21.0	CF/CM/CU48D	1150	36.0	27.4	16.00	13.25
TW4B3621S	TPLC120C20MP13C	21.0	CF/CM/CU36C	1150	36.0	27.6	15.50	12.50
TW4B3621S	TPLC120C20MP13C	21.0	CF/CM/CU36D	1150	36.0	27.6	15.75	13.00
TW4B3621S	TPLC120C20MP13C	21.0	CF/CM/CU42C	1150	36.0	27.2	15.50	12.75
TW4B3621S	TPLC120C20MP13C	21.0	CF/CM/CU42D	1150	36.0	27.2	15.75	13.25
TW4B3621S	TPLC120C20MP13C	21.0	CF/CM/CU48C	1150	36.0	27.4	15.75	12.75
TW4B3621S	TPLC120C20MP13C	21.0	CF/CM/CU48D	1150	36.0	27.4	16.00	13.25
TW4B3621S	CP9C060B12MP13C	17.5	CF/CM/CU36B	1000	35.8	26.0	14.75	12.50
TW4B3621S	CP9C060B12MP13C	17.5	CF/CM/CU36C	1000	36.0	26.4	14.75	12.50
TW4B3621S	CP9C060B12MP13C	17.5	CF/CM/CU42C	1000	36.0	26.0	14.75	12.50
TW4B3621S	CP9C060B12MP13C	17.5	CF/CM/CU48C	1000	36.0	26.2	14.75	12.50
TW4B3621S	CP9C060B12MP13C	17.5	CF42B	1000	36.0	26.0	14.75	12.50
TW4B3621S	CP9C080B12MP13C	17.5	CF/CM/CU36B	975	35.8	26.2	15.00	12.50
TW4B3621S	CP9C080B12MP13C	17.5	CF42B	975	36.0	25.8	15.25	12.50
TW4B3621S	CP9C080C16MP13C	21.0	CF/CM/CU36C	1025	36.0	26.6	15.25	12.50
TW4B3621S	CP9C080C16MP13C	21.0	CF/CM/CU42C	1025	36.0	26.0	15.50	12.75
TW4B3621S	CP9C080C16MP13C	21.0	CF/CM/CU48C	1025	36.0	26.4	15.50	12.75
TW4B3621S	CP9C080C16MP13C	21.0	CF/CM/CU48D	1025	36.0	26.4	15.50	12.75
TW4B3621S	CP9C080C16MP13C	21.0	CF/CM36D	1025	36.0	26.6	15.50	12.75
TW4B3621S	CP9C080C16MP13C	21.0	CF/CM42D	1025	36.0	26.0	15.50	12.75
TW4B3621S	CP9C100C16MP13C	21.0	CF/CM/CU36C	1000	36.0	26.2	15.50	12.50
TW4B3621S	CP9C100C16MP13C	21.0	CF/CM/CU36D	1075	36.0	27.0	15.50	13.00
TW4B3621S	CP9C100C16MP13C	21.0	CF/CM/CU42C	1000	36.0	26.0	15.50	12.75
TW4B3621S	CP9C100C16MP13C	21.0	CF/CM/CU42D	1050	36.0	26.6	15.75	13.00
TW4B3621S	CP9C100C16MP13C	21.0	CF/CM/CU48C	1075	36.0	27.0	15.75	12.75
TW4B3621S	CP9C100C16MP13C	21.0	CF/CM/CU48D	1075	36.0	27.0	15.50	12.75
TW4B3621S	CP9C100C20MP13C	21.0	CF/CM/CU36C	1100	36.0	27.2	15.25	12.50
TW4B3621S	CP9C100C20MP13C	21.0	CF/CM/CU36D	1100	36.0	27.2	15.50	13.00
TW4B3621S	CP9C100C20MP13C	21.0	CF/CM/CU42C	1100	36.0	26.8	15.25	12.75
TW4B3621S	CP9C100C20MP13C	21.0	CF/CM/CU42D	1100	36.0	26.8	15.50	13.00
TW4B3621S	CP9C100C20MP13C	21.0	CF/CM/CU48C	1100	36.0	27.0	15.50	12.50
TW4B3621S	CP9C100C20MP13C	21.0	CF/CM/CU48D	1100	36.0	27.0	15.50	12.50
TW4B3621S	CP9C120D20MP13C	24.5	CF/CM/CU36D	1050	36.0	26.8	15.75	13.00
TW4B3621S	CP9C120D20MP13C	24.5	CF/CM/CU42D	1050	36.0	26.4	15.75	12.75
TW4B3621S	CP9C120D20MP13C	24.5	CF/CM/CU48D	1050	36.0	26.8	15.75	12.75

COOLING CAPACITY - With High Efficiency Motor Furnaces¹ (Continued)

UNIT MODEL	FURNACE		COIL MODEL ²	COOLING				
	MODEL	WIDTH		RATED CFM	NET MBH		SEER	EER
					TOTAL	SENS.		
TW4B3621S	CPLC080C16MP13C	21.0	CF/CM/CU36C	1050	36.0	26.8	15.50	12.50
TW4B3621S	CPLC080C16MP13C	21.0	CF/CM/CU36D	1050	36.0	26.8	15.50	13.00
TW4B3621S	CPLC080C16MP13C	21.0	CF/CM/CU42C	1050	36.0	26.6	15.50	12.75
TW4B3621S	CPLC080C16MP13C	21.0	CF/CM/CU42D	1050	36.0	26.6	15.75	13.00
TW4B3621S	CPLC080C16MP13C	21.0	CF/CM/CU48C	1050	36.0	26.8	15.50	12.75
TW4B3621S	CPLC080C16MP13C	21.0	CF/CM/CU48D	1050	36.0	26.8	15.50	12.75
TW4B3621S	CPLC100C16MP13C	21.0	CF/CM/CU36C	1050	36.0	26.8	15.50	12.50
TW4B3621S	CPLC100C16MP13C	21.0	CF/CM/CU36D	1050	36.0	26.8	15.50	13.00
TW4B3621S	CPLC100C16MP13C	21.0	CF/CM/CU42C	1050	36.0	26.6	15.50	12.75
TW4B3621S	CPLC100C16MP13C	21.0	CF/CM/CU42D	1050	36.0	26.6	15.75	13.00
TW4B3621S	CPLC100C16MP13C	21.0	CF/CM/CU48C	1050	36.0	26.8	15.50	12.75
TW4B3621S	CPLC100C16MP13C	21.0	CF/CM/CU48D	1050	36.0	26.8	15.50	12.75
TW4B3621S	CPLC100C20MP13C	21.0	CF/CM/CU36C	1150	36.0	27.6	15.50	12.50
TW4B3621S	CPLC100C20MP13C	21.0	CF/CM/CU36D	1150	36.0	27.6	15.75	13.00
TW4B3621S	CPLC100C20MP13C	21.0	CF/CM/CU42C	1150	36.0	27.2	15.50	12.75
TW4B3621S	CPLC100C20MP13C	21.0	CF/CM/CU42D	1150	36.0	27.2	15.75	13.25
TW4B3621S	CPLC100C20MP13C	21.0	CF/CM/CU48C	1150	36.0	27.4	15.75	12.75
TW4B3621S	CPLC100C20MP13C	21.0	CF/CM/CU48D	1150	36.0	27.4	16.00	13.25
TW4B3621S	CPLC120C20MP13C	21.0	CF/CM/CU36C	1150	36.0	27.6	15.50	12.50
TW4B3621S	CPLC120C20MP13C	21.0	CF/CM/CU36D	1150	36.0	27.6	15.75	13.00
TW4B3621S	CPLC120C20MP13C	21.0	CF/CM/CU42C	1150	36.0	27.2	15.50	12.75
TW4B3621S	CPLC120C20MP13C	21.0	CF/CM/CU42D	1150	36.0	27.2	15.75	13.25
TW4B3621S	CPLC120C20MP13C	21.0	CF/CM/CU48C	1150	36.0	27.4	15.75	12.75
TW4B3621S	CPLC120C20MP13C	21.0	CF/CM/CU48D	1150	36.0	27.4	16.00	13.25
TW4B4221S	TL8E080C16UH11	21.0	CF/CM/CU42C	1275	40.5	31.2	15.00	12.50
TW4B4221S	TL8E080C16UH11	21.0	CF/CM/CU48C	1275	41.0	31.2	15.00	12.50
TW4B4221S	TL8E080C16UH11	21.0	CF/CM/CU48D	1300	41.0	31.4	15.00	12.50
TW4B4221S	TL8E080C16UH11	21.0	CF/CM/CU60C	1275	40.5	30.6	14.75	12.50
TW4B4221S	TL8E080C16UH11	21.0	CF/CM42D	1300	40.5	31.4	14.75	12.50
TW4B4221S	TL8E080C16UH11	21.0	CF/CM64D	1275	42.0	32.0	15.25	12.50
TW4B4221S	TL8E100C20UH11	21.0	CF/CM/CU42C	1250	40.5	31.0	15.25	12.50
TW4B4221S	TL8E100C20UH11	21.0	CF/CM/CU48C	1250	41.0	31.0	15.50	12.75
TW4B4221S	TL8E100C20UH11	21.0	CF/CM/CU48D	1275	41.0	31.2	15.25	12.50
TW4B4221S	TL8E100C20UH11	21.0	CF/CM/CU60C	1250	40.5	30.4	15.25	12.50
TW4B4221S	TL8E100C20UH11	21.0	CF/CM42D	1275	41.0	31.4	15.25	12.50
TW4B4221S	TL8E100C20UH11	21.0	CF/CM64D	1250	42.0	31.8	15.50	12.75
TW4B4221S	TL9E060B12UH11	17.5	CF/CM/CU42C	1225	40.0	30.0	14.00	12.20
TW4B4221S	TL9E060B12UH11	17.5	CF/CM/CU48C	1225	40.5	30.2	14.00	12.20
TW4B4221S	TL9E060B12UH11	17.5	CF/CM/CU60C	1225	40.0	29.8	14.00	12.20
TW4B4221S	TL9E080C16UH11	21.0	CF/CM/CU42C	1250	40.5	31.0	14.75	12.50
TW4B4221S	TL9E080C16UH11	21.0	CF/CM/CU48C	1250	41.0	31.0	14.75	12.50
TW4B4221S	TL9E080C16UH11	21.0	CF/CM/CU48D	1275	41.0	31.2	14.75	12.50
TW4B4221S	TL9E080C16UH11	21.0	CF/CM/CU60C	1250	40.5	30.4	14.75	12.50
TW4B4221S	TL9E080C16UH11	21.0	CF/CM42D	1275	40.5	31.2	14.75	12.50
TW4B4221S	TL9E080C16UH11	21.0	CF/CM64D	1250	41.5	31.4	15.00	12.50
TW4B4221S	TL9E100C20UH11	21.0	CF/CM/CU42C	1225	40.5	30.4	15.25	12.50
TW4B4221S	TL9E100C20UH11	21.0	CF/CM/CU48C	1225	41.0	30.8	15.25	12.50
TW4B4221S	TL9E100C20UH11	21.0	CF/CM/CU48D	1250	41.0	31.0	15.25	12.50
TW4B4221S	TL9E100C20UH11	21.0	CF/CM/CU60C	1225	40.5	30.0	15.25	12.50
TW4B4221S	TL9E100C20UH11	21.0	CF/CM42D	1250	40.5	31.0	15.25	12.50
TW4B4221S	TL9E100C20UH11	21.0	CF/CM64D	1225	41.5	31.0	15.50	12.75
TW4B4221S	TM8V080C16MP11C	21.0	CF/CM/CU42C	1275	40.0	30.8	14.50	12.50
TW4B4221S	TM8V080C16MP11C	21.0	CF/CM/CU48C	1375	41.0	32.2	14.50	12.50

COOLING CAPACITY - With High Efficiency Motor Furnaces¹ (Continued)

UNIT MODEL	FURNACE		COIL MODEL ²	COOLING				
	MODEL	WIDTH		RATED CFM	NET MBH		SEER	EER
					TOTAL	SENS.		
TW4B4221S	TM8V080C16MP11C	21.0	CF/CM/CU48D	1375	41.0	32.2	14.75	12.50
TW4B4221S	TM8V080C16MP11C	21.0	CF/CM/CU60C	1275	40.5	30.8	15.00	12.50
TW4B4221S	TM8V080C16MP11C	21.0	CF/CM64D	1375	42.0	33.0	15.00	12.50
TW4B4221S	TM8V080C16MP12C	21.0	CF/CM/CU42C	1275	40.0	30.8	14.50	12.50
TW4B4221S	TM8V080C16MP12C	21.0	CF/CM/CU42D	1275	40.0	30.8	14.75	12.75
TW4B4221S	TM8V080C16MP12C	21.0	CF/CM/CU48C	1375	41.0	32.2	14.50	12.50
TW4B4221S	TM8V080C16MP12C	21.0	CF/CM/CU48D	1375	41.0	32.2	14.75	12.50
TW4B4221S	TM8V080C16MP12C	21.0	CF/CM/CU60C	1275	40.5	30.8	15.00	12.50
TW4B4221S	TM8V080C16MP12C	21.0	CF/CM/CU60D	1425	41.5	33.2	15.00	13.00
TW4B4221S	TM8V080C16MP12C	21.0	CF/CM64D	1375	42.0	33.0	15.00	12.50
TW4B4221S	TM8V100C16MP11C	21.0	CF/CM/CU42C	1275	40.0	30.8	14.50	12.50
TW4B4221S	TM8V100C16MP11C	21.0	CF/CM/CU48C	1375	41.0	32.2	14.50	12.50
TW4B4221S	TM8V100C16MP11C	21.0	CF/CM/CU48D	1375	41.0	32.2	14.75	12.50
TW4B4221S	TM8V100C16MP11C	21.0	CF/CM/CU60C	1275	40.5	30.8	15.00	12.50
TW4B4221S	TM8V100C16MP11C	21.0	CF/CM64D	1375	42.0	33.0	15.00	12.50
TW4B4221S	TM8V100C16MP12C	21.0	CF/CM/CU42C	1275	40.0	30.8	14.50	12.50
TW4B4221S	TM8V100C16MP12C	21.0	CF/CM/CU42D	1275	40.0	30.8	14.75	12.75
TW4B4221S	TM8V100C16MP12C	21.0	CF/CM/CU48C	1375	41.0	32.2	14.50	12.50
TW4B4221S	TM8V100C16MP12C	21.0	CF/CM/CU48D	1375	41.0	32.2	14.75	12.50
TW4B4221S	TM8V100C16MP12C	21.0	CF/CM/CU60C	1275	40.5	30.8	15.00	12.50
TW4B4221S	TM8V100C16MP12C	21.0	CF/CM/CU60D	1425	41.5	33.2	15.00	13.00
TW4B4221S	TM8V100C16MP12C	21.0	CF/CM64D	1375	42.0	33.0	15.00	12.50
TW4B4221S	TM8V100C20MP11C	21.0	CF/CM/CU42C	1325	40.5	31.4	15.00	12.50
TW4B4221S	TM8V100C20MP11C	21.0	CF/CM/CU48C	1325	41.0	31.6	15.00	12.50
TW4B4221S	TM8V100C20MP11C	21.0	CF/CM/CU60C	1425	42.0	33.6	15.00	12.50
TW4B4221S	TM8V100C20MP11C	21.0	CF/CM/CU60D	1425	42.0	33.8	15.25	12.50
TW4B4221S	TM8V100C20MP11C	21.0	CF/CM64D	1375	42.0	33.0	15.25	12.75
TW4B4221S	TM8V100C20MP12C	21.0	CF/CM/CU42C	1325	40.5	31.4	15.00	12.50
TW4B4221S	TM8V100C20MP12C	21.0	CF/CM/CU42D	1325	40.5	31.4	15.00	13.00
TW4B4221S	TM8V100C20MP12C	21.0	CF/CM/CU48C	1325	41.0	31.6	15.00	12.50
TW4B4221S	TM8V100C20MP12C	21.0	CF/CM/CU48D	1375	41.5	32.6	15.25	13.00
TW4B4221S	TM8V100C20MP12C	21.0	CF/CM/CU60C	1425	42.0	33.6	15.00	12.50
TW4B4221S	TM8V100C20MP12C	21.0	CF/CM/CU60D	1425	42.0	33.8	15.25	12.50
TW4B4221S	TM8V100C20MP12C	21.0	CF/CM64D	1375	42.0	33.0	15.25	12.75
TW4B4221S	TM8V120C20MP12C	21.0	CF/CM/CU42C	1325	40.5	31.4	15.00	12.50
TW4B4221S	TM8V120C20MP12C	21.0	CF/CM/CU42D	1325	40.5	31.4	15.00	13.00
TW4B4221S	TM8V120C20MP12C	21.0	CF/CM/CU48C	1325	41.0	31.6	15.00	12.50
TW4B4221S	TM8V120C20MP12C	21.0	CF/CM/CU48D	1375	41.5	32.6	15.25	13.00
TW4B4221S	TM8V120C20MP12C	21.0	CF/CM/CU60C	1425	42.0	33.6	15.00	12.50
TW4B4221S	TM8V120C20MP12C	21.0	CF/CM/CU60D	1425	42.0	33.8	15.25	12.50
TW4B4221S	TM8V120C20MP12C	21.0	CF/CM64D	1375	42.0	33.0	15.25	12.75
TW4B4221S	TM8X080C16MP11	21.0	CF/CM/CU42C	1375	41.0	32.6	14.75	12.50
TW4B4221S	TM8X080C16MP11	21.0	CF/CM/CU42D	1175	39.5	29.0	14.75	12.50
TW4B4221S	TM8X080C16MP11	21.0	CF/CM/CU48C	1375	41.0	32.2	14.75	12.50
TW4B4221S	TM8X080C16MP11	21.0	CF/CM/CU48D	1400	41.5	32.8	14.75	12.50
TW4B4221S	TM8X080C16MP11	21.0	CF/CM/CU60C	1375	41.5	32.8	15.00	12.50
TW4B4221S	TM8X080C16MP11	21.0	CF/CM/CU60D	1400	41.5	33.0	15.00	12.50
TW4B4221S	TM8X080C16MP11	21.0	CF/CM42D	1175	39.5	29.0	14.75	12.50
TW4B4221S	TM8X080C16MP11	21.0	CF/CM64D	1375	42.0	33.0	15.00	12.50
TW4B4221S	TM8X100C16MP11	21.0	CF/CM/CU42C	1375	41.0	32.6	14.75	12.50
TW4B4221S	TM8X100C16MP11	21.0	CF/CM/CU42D	1175	39.5	29.0	14.75	12.50
TW4B4221S	TM8X100C16MP11	21.0	CF/CM/CU48C	1375	41.0	32.2	14.75	12.50
TW4B4221S	TM8X100C16MP11	21.0	CF/CM/CU48D	1400	41.5	32.8	14.75	12.50

COOLING CAPACITY - With High Efficiency Motor Furnaces¹ (Continued)

UNIT MODEL	FURNACE		COIL MODEL ²	COOLING				
	MODEL	WIDTH		RATED CFM	NET MBH		SEER	EER
					TOTAL	SENS.		
TW4B4221S	TM8X100C16MP11	21.0	CF/CM/CU60C	1375	41.5	32.8	15.00	12.50
TW4B4221S	TM8X100C16MP11	21.0	CF/CM/CU60D	1400	41.5	33.0	15.00	12.50
TW4B4221S	TM8X100C16MP11	21.0	CF/CM42D	1175	39.5	29.0	14.75	12.50
TW4B4221S	TM8X100C16MP11	21.0	CF/CM64D	1375	42.0	33.0	15.00	12.50
TW4B4221S	TM8X100C20MP11	21.0	CF/CM/CU42C	1400	41.0	32.4	14.75	12.50
TW4B4221S	TM8X100C20MP11	21.0	CF/CM/CU42D	1250	40.0	30.6	15.25	12.75
TW4B4221S	TM8X100C20MP11	21.0	CF/CM/CU48C	1400	41.5	32.8	15.00	12.50
TW4B4221S	TM8X100C20MP11	21.0	CF/CM/CU48D	1425	41.5	33.0	15.25	12.75
TW4B4221S	TM8X100C20MP11	21.0	CF/CM/CU60C	1400	41.5	32.8	15.25	12.75
TW4B4221S	TM8X100C20MP11	21.0	CF/CM/CU60D	1425	42.0	33.8	15.25	12.75
TW4B4221S	TM8X100C20MP11	21.0	CF/CM42D	1250	40.0	30.6	15.25	12.75
TW4B4221S	TM8X100C20MP11	21.0	CF/CM64D	1400	42.0	33.4	15.50	12.75
TW4B4221S	TM8X120C20MP11	21.0	CF/CM/CU42C	1400	41.0	32.4	14.75	12.50
TW4B4221S	TM8X120C20MP11	21.0	CF/CM/CU42D	1250	40.0	30.6	15.25	12.75
TW4B4221S	TM8X120C20MP11	21.0	CF/CM/CU48C	1400	41.5	32.8	15.00	12.50
TW4B4221S	TM8X120C20MP11	21.0	CF/CM/CU48D	1425	41.5	33.0	15.25	12.75
TW4B4221S	TM8X120C20MP11	21.0	CF/CM/CU60C	1400	41.5	32.8	15.25	12.75
TW4B4221S	TM8X120C20MP11	21.0	CF/CM/CU60D	1425	42.0	33.8	15.25	12.75
TW4B4221S	TM8X120C20MP11	21.0	CF/CM42D	1250	40.0	30.6	15.25	12.75
TW4B4221S	TM8X120C20MP11	21.0	CF/CM64D	1400	42.0	33.4	15.50	12.75
TW4B4221S	TM8Y080B12MP11	17.5	CF42B	1175	40.0	29.4	14.50	12.50
TW4B4221S	TM8Y080C16MP11	21.0	CF/CM/CU42C	1375	41.0	32.6	14.75	12.50
TW4B4221S	TM8Y080C16MP11	21.0	CF/CM/CU42D	1175	39.5	29.0	14.75	12.50
TW4B4221S	TM8Y080C16MP11	21.0	CF/CM/CU48C	1375	41.0	32.2	14.75	12.50
TW4B4221S	TM8Y080C16MP11	21.0	CF/CM/CU48D	1400	41.5	32.8	14.75	12.50
TW4B4221S	TM8Y080C16MP11	21.0	CF/CM/CU60C	1375	41.5	32.8	15.00	12.50
TW4B4221S	TM8Y080C16MP11	21.0	CF/CM/CU60D	1400	41.5	33.0	15.00	12.50
TW4B4221S	TM8Y080C16MP11	21.0	CF/CM42D	1175	39.5	29.0	14.75	12.50
TW4B4221S	TM8Y080C16MP11	21.0	CF/CM64D	1375	42.0	33.0	15.00	12.50
TW4B4221S	TM8Y100C16MP11	21.0	CF/CM/CU42C	1375	41.0	32.6	14.75	12.50
TW4B4221S	TM8Y100C16MP11	21.0	CF/CM/CU42D	1175	39.5	29.0	14.75	12.50
TW4B4221S	TM8Y100C16MP11	21.0	CF/CM/CU48C	1375	41.0	32.2	14.75	12.50
TW4B4221S	TM8Y100C16MP11	21.0	CF/CM/CU48D	1400	41.5	32.8	14.75	12.50
TW4B4221S	TM8Y100C16MP11	21.0	CF/CM/CU60C	1375	41.5	32.8	15.00	12.50
TW4B4221S	TM8Y100C16MP11	21.0	CF/CM/CU60D	1400	41.5	33.0	15.00	12.50
TW4B4221S	TM8Y100C16MP11	21.0	CF/CM42D	1175	39.5	29.0	14.75	12.50
TW4B4221S	TM8Y100C16MP11	21.0	CF/CM64D	1375	42.0	33.0	15.00	12.50
TW4B4221S	TM8Y100C20MP11	21.0	CF/CM/CU42C	1400	41.0	32.4	14.75	12.50
TW4B4221S	TM8Y100C20MP11	21.0	CF/CM/CU42D	1250	40.0	30.6	15.25	12.75
TW4B4221S	TM8Y100C20MP11	21.0	CF/CM/CU48C	1400	41.5	32.8	15.00	12.50
TW4B4221S	TM8Y100C20MP11	21.0	CF/CM/CU48D	1425	41.5	33.0	15.25	12.75
TW4B4221S	TM8Y100C20MP11	21.0	CF/CM/CU60C	1400	41.5	32.8	15.25	12.75
TW4B4221S	TM8Y100C20MP11	21.0	CF/CM/CU60D	1425	42.0	33.8	15.25	12.75
TW4B4221S	TM8Y100C20MP11	21.0	CF/CM42D	1250	40.0	30.6	15.25	12.75
TW4B4221S	TM8Y100C20MP11	21.0	CF/CM64D	1400	42.0	33.4	15.50	12.75
TW4B4221S	TM8Y120C20MP11	21.0	CF/CM/CU42C	1400	41.0	32.4	14.75	12.50
TW4B4221S	TM8Y120C20MP11	21.0	CF/CM/CU42D	1250	40.0	30.6	15.25	12.75
TW4B4221S	TM8Y120C20MP11	21.0	CF/CM/CU48C	1400	41.5	32.8	15.00	12.50
TW4B4221S	TM8Y120C20MP11	21.0	CF/CM/CU48D	1425	41.5	33.0	15.25	12.75
TW4B4221S	TM8Y120C20MP11	21.0	CF/CM/CU60C	1400	41.5	32.8	15.25	12.75
TW4B4221S	TM8Y120C20MP11	21.0	CF/CM/CU60D	1425	42.0	33.8	15.25	12.75
TW4B4221S	TM8Y120C20MP11	21.0	CF/CM42D	1250	40.0	30.6	15.25	12.75
TW4B4221S	TM8Y120C20MP11	21.0	CF/CM64D	1400	42.0	33.4	15.50	12.75

COOLING CAPACITY - With High Efficiency Motor Furnaces¹ (Continued)

UNIT MODEL	FURNACE		COIL MODEL ²	COOLING				
	MODEL	WIDTH		RATED CFM	NET MBH		SEER	EER
					TOTAL	SENS.		
TW4B4221S	TM9E080C16MP11	21.0	CF/CM/CU42C	1250	40.5	31.0	14.75	12.50
TW4B4221S	TM9E080C16MP11	21.0	CF/CM/CU48C	1275	41.0	31.2	14.75	12.50
TW4B4221S	TM9E080C16MP11	21.0	CF/CM/CU48D	1275	41.0	31.2	14.75	12.50
TW4B4221S	TM9E080C16MP11	21.0	CF/CM/CU60C	1250	40.5	30.4	14.75	12.50
TW4B4221S	TM9E080C16MP11	21.0	CF/CM/CU60D	1275	40.5	30.6	14.75	12.50
TW4B4221S	TM9E080C16MP11	21.0	CF/CM42D	1275	40.5	31.2	14.75	12.50
TW4B4221S	TM9E080C16MP11	21.0	CF/CM64D	1275	41.5	31.6	15.25	12.75
TW4B4221S	TM9E100C16MP11	21.0	CF/CM/CU42C	1275	40.0	30.8	14.75	12.50
TW4B4221S	TM9E100C16MP11	21.0	CF/CM/CU42D	1175	39.5	29.0	14.50	12.50
TW4B4221S	TM9E100C16MP11	21.0	CF/CM/CU48C	1275	40.0	30.4	14.50	12.50
TW4B4221S	TM9E100C16MP11	21.0	CF/CM/CU48D	1300	40.5	31.0	14.75	12.50
TW4B4221S	TM9E100C16MP11	21.0	CF/CM/CU60C	1275	40.5	30.8	14.75	12.50
TW4B4221S	TM9E100C16MP11	21.0	CF/CM/CU60D	1300	40.5	31.4	14.75	12.50
TW4B4221S	TM9E100C16MP11	21.0	CF/CM42D	1175	39.5	29.0	14.50	12.50
TW4B4221S	TM9E100C16MP11	21.0	CF/CM64D	1275	41.0	31.2	15.00	12.75
TW4B4221S	TM9E100C20MP11	21.0	CF/CM/CU42C	1350	40.5	31.8	14.75	12.50
TW4B4221S	TM9E100C20MP11	21.0	CF/CM/CU42D	1200	39.5	29.4	14.75	12.50
TW4B4221S	TM9E100C20MP11	21.0	CF/CM/CU48C	1350	41.0	31.8	14.75	12.50
TW4B4221S	TM9E100C20MP11	21.0	CF/CM/CU48D	1375	41.0	32.2	15.00	12.50
TW4B4221S	TM9E100C20MP11	21.0	CF/CM/CU60C	1350	41.0	32.0	15.00	12.75
TW4B4221S	TM9E100C20MP11	21.0	CF/CM/CU60D	1200	39.5	29.6	15.25	12.75
TW4B4221S	TM9E100C20MP11	21.0	CF/CM42D	1200	39.5	29.4	14.75	12.50
TW4B4221S	TM9E100C20MP11	21.0	CF/CM64D	1375	42.0	33.0	15.25	12.75
TW4B4221S	TM9E120D20MP11	24.5	CF/CM/CU42D	1250	40.0	30.6	15.25	12.75
TW4B4221S	TM9E120D20MP11	24.5	CF/CM/CU48D	1250	40.0	30.2	15.25	12.75
TW4B4221S	TM9E120D20MP11	24.5	CF/CM/CU60D	1425	42.0	33.8	15.25	12.75
TW4B4221S	TM9E120D20MP11	24.5	CF/CM42D	1250	40.0	30.6	15.25	12.75
TW4B4221S	TM9E120D20MP11	24.5	CF/CM64D	1400	42.0	33.4	15.25	12.75
TW4B4221S	TM9V080B12MP11C	17.5	CF42B	1175	39.0	28.6	14.00	12.25
TW4B4221S	TM9V080B12MP12C	17.5	CF42B	1175	39.0	28.6	14.00	12.25
TW4B4221S	TM9V080C16MP11C	21.0	CF/CM/CU42C	1225	40.5	30.4	14.75	12.50
TW4B4221S	TM9V080C16MP11C	21.0	CF/CM/CU48C	1225	40.5	30.2	14.75	12.50
TW4B4221S	TM9V080C16MP11C	21.0	CF/CM/CU48D	1225	40.5	30.2	15.00	12.50
TW4B4221S	TM9V080C16MP11C	21.0	CF/CM/CU60C	1225	40.5	30.0	14.75	12.50
TW4B4221S	TM9V080C16MP11C	21.0	CF/CM/CU60D	1225	40.5	30.2	14.75	12.50
TW4B4221S	TM9V080C16MP11C	21.0	CF/CM42D	1225	40.5	30.4	14.75	12.50
TW4B4221S	TM9V080C16MP11C	21.0	CF/CM64D	1225	41.5	31.0	15.00	12.50
TW4B4221S	TM9V080C16MP12C	21.0	CF/CM/CU42C	1225	40.5	30.4	14.75	12.50
TW4B4221S	TM9V080C16MP12C	21.0	CF/CM/CU48C	1225	40.5	30.2	14.75	12.50
TW4B4221S	TM9V080C16MP12C	21.0	CF/CM/CU48D	1225	40.5	30.2	15.00	12.50
TW4B4221S	TM9V080C16MP12C	21.0	CF/CM/CU60C	1225	40.5	30.0	14.75	12.50
TW4B4221S	TM9V080C16MP12C	21.0	CF/CM/CU60D	1225	40.5	30.2	14.75	12.50
TW4B4221S	TM9V080C16MP12C	21.0	CF/CM42D	1225	40.5	30.4	14.75	12.50
TW4B4221S	TM9V080C16MP12C	21.0	CF/CM64D	1225	41.5	31.0	15.00	12.50
TW4B4221S	TM9V100C16MP11C	21.0	CF/CM/CU42C	1325	40.5	31.4	14.75	12.50
TW4B4221S	TM9V100C16MP11C	21.0	CF/CM/CU48C	1275	40.5	30.8	14.75	12.50
TW4B4221S	TM9V100C16MP11C	21.0	CF/CM/CU48D	1300	40.5	31.0	15.00	12.50
TW4B4221S	TM9V100C16MP11C	21.0	CF/CM/CU60C	1275	40.5	30.8	15.00	12.50
TW4B4221S	TM9V100C16MP11C	21.0	CF/CM/CU60D	1300	40.5	31.2	14.75	12.50
TW4B4221S	TM9V100C16MP11C	21.0	CF/CM64D	1275	41.0	31.4	15.00	12.50
TW4B4221S	TM9V100C16MP12C	21.0	CF/CM/CU42C	1325	40.5	31.4	14.75	12.50
TW4B4221S	TM9V100C16MP12C	21.0	CF/CM/CU42D	1300	40.0	31.0	14.75	12.75
TW4B4221S	TM9V100C16MP12C	21.0	CF/CM/CU48C	1275	40.5	30.8	14.75	12.50

COOLING CAPACITY - With High Efficiency Motor Furnaces¹ (Continued)

UNIT MODEL	FURNACE		COIL MODEL ²	COOLING				
	MODEL	WIDTH		RATED CFM	NET MBH		SEER	EER
					TOTAL	SENS.		
TW4B4221S	TM9V100C16MP12C	21.0	CF/CM/CU48D	1300	40.5	31.0	15.00	12.50
TW4B4221S	TM9V100C16MP12C	21.0	CF/CM/CU60C	1275	40.5	30.8	15.00	12.50
TW4B4221S	TM9V100C16MP12C	21.0	CF/CM/CU60D	1300	40.5	31.2	14.75	12.50
TW4B4221S	TM9V100C16MP12C	21.0	CF/CM64D	1275	41.0	31.4	15.00	12.50
TW4B4221S	TM9V100C20MP11C	21.0	CF/CM/CU42C	1225	39.5	29.6	14.50	12.50
TW4B4221S	TM9V100C20MP11C	21.0	CF/CM/CU48C	1350	41.0	31.8	14.75	12.50
TW4B4221S	TM9V100C20MP11C	21.0	CF/CM/CU48D	1350	41.0	31.8	14.75	12.50
TW4B4221S	TM9V100C20MP11C	21.0	CF/CM/CU60C	1350	41.0	31.8	14.75	12.50
TW4B4221S	TM9V100C20MP11C	21.0	CF/CM/CU60D	1350	41.0	31.8	15.00	12.50
TW4B4221S	TM9V100C20MP11C	21.0	CF/CM64D	1350	41.5	32.4	15.00	12.50
TW4B4221S	TM9V100C20MP12C	21.0	CF/CM/CU42C	1225	39.5	29.6	14.50	12.50
TW4B4221S	TM9V100C20MP12C	21.0	CF/CM/CU42D	1350	40.5	31.8	14.75	12.75
TW4B4221S	TM9V100C20MP12C	21.0	CF/CM/CU48C	1350	41.0	31.8	14.75	12.50
TW4B4221S	TM9V100C20MP12C	21.0	CF/CM/CU48D	1350	41.0	31.8	14.75	12.50
TW4B4221S	TM9V100C20MP12C	21.0	CF/CM/CU60C	1350	41.0	31.8	14.75	12.50
TW4B4221S	TM9V100C20MP12C	21.0	CF/CM/CU60D	1350	41.0	31.8	15.00	12.50
TW4B4221S	TM9V100C20MP12C	21.0	CF/CM64D	1350	41.5	32.4	15.00	12.50
TW4B4221S	TM9V120D20MP11C	24.5	CF/CM/CU48D	1400	41.5	32.8	15.00	12.50
TW4B4221S	TM9V120D20MP11C	24.5	CF/CM/CU60D	1400	41.5	32.8	15.25	12.50
TW4B4221S	TM9V120D20MP11C	24.5	CF/CM42D	1400	41.0	32.4	15.00	12.50
TW4B4221S	TM9V120D20MP11C	24.5	CF/CM64D	1400	42.0	33.4	15.25	12.75
TW4B4221S	TM9V120D20MP12C	24.5	CF/CM/CU42D	1400	41.0	32.4	15.00	12.50
TW4B4221S	TM9V120D20MP12C	24.5	CF/CM/CU48D	1400	41.5	32.8	15.00	12.50
TW4B4221S	TM9V120D20MP12C	24.5	CF/CM/CU60D	1400	41.5	32.8	15.25	12.50
TW4B4221S	TM9V120D20MP12C	24.5	CF/CM64D	1400	42.0	33.4	15.25	12.75
TW4B4221S	TM9Y080C16MP11	21.0	CF/CM/CU42C	1250	40.5	31.0	14.75	12.50
TW4B4221S	TM9Y080C16MP11	21.0	CF/CM/CU48C	1275	41.0	31.2	14.75	12.50
TW4B4221S	TM9Y080C16MP11	21.0	CF/CM/CU48D	1275	41.0	31.2	14.75	12.50
TW4B4221S	TM9Y080C16MP11	21.0	CF/CM/CU60C	1250	40.5	30.4	14.75	12.50
TW4B4221S	TM9Y080C16MP11	21.0	CF/CM/CU60D	1275	40.5	30.6	14.75	12.50
TW4B4221S	TM9Y080C16MP11	21.0	CF/CM42D	1275	40.5	31.2	14.75	12.50
TW4B4221S	TM9Y080C16MP11	21.0	CF/CM64D	1275	41.5	31.6	15.25	12.75
TW4B4221S	TM9Y100C16MP11	21.0	CF/CM/CU42C	1275	40.0	30.8	14.75	12.50
TW4B4221S	TM9Y100C16MP11	21.0	CF/CM/CU42D	1175	39.5	29.0	14.50	12.50
TW4B4221S	TM9Y100C16MP11	21.0	CF/CM/CU48C	1275	40.0	30.4	14.50	12.50
TW4B4221S	TM9Y100C16MP11	21.0	CF/CM/CU48D	1300	40.5	31.0	14.75	12.50
TW4B4221S	TM9Y100C16MP11	21.0	CF/CM/CU60C	1275	40.5	30.8	14.75	12.50
TW4B4221S	TM9Y100C16MP11	21.0	CF/CM/CU60D	1300	40.5	31.4	14.75	12.50
TW4B4221S	TM9Y100C16MP11	21.0	CF/CM42D	1175	39.5	29.0	14.50	12.50
TW4B4221S	TM9Y100C16MP11	21.0	CF/CM64D	1275	41.0	31.2	15.00	12.75
TW4B4221S	TM9Y100C20MP11	21.0	CF/CM/CU42C	1350	40.5	31.8	14.75	12.50
TW4B4221S	TM9Y100C20MP11	21.0	CF/CM/CU42D	1200	39.5	29.4	14.75	12.50
TW4B4221S	TM9Y100C20MP11	21.0	CF/CM/CU48C	1350	41.0	31.8	14.75	12.50
TW4B4221S	TM9Y100C20MP11	21.0	CF/CM/CU48D	1375	41.0	32.2	15.00	12.50
TW4B4221S	TM9Y100C20MP11	21.0	CF/CM/CU60C	1350	41.0	32.0	15.00	12.75
TW4B4221S	TM9Y100C20MP11	21.0	CF/CM/CU60D	1200	39.5	29.6	15.25	12.75
TW4B4221S	TM9Y100C20MP11	21.0	CF/CM42D	1200	39.5	29.4	14.75	12.50
TW4B4221S	TM9Y100C20MP11	21.0	CF/CM64D	1375	42.0	33.0	15.25	12.75
TW4B4221S	TM9Y120D20MP11	24.5	CF/CM/CU42D	1250	40.0	30.6	15.25	12.75
TW4B4221S	TM9Y120D20MP11	24.5	CF/CM/CU48D	1250	40.0	30.2	15.25	12.75
TW4B4221S	TM9Y120D20MP11	24.5	CF/CM/CU60D	1425	42.0	33.8	15.25	12.75
TW4B4221S	TM9Y120D20MP11	24.5	CF/CM42D	1250	40.0	30.6	15.25	12.75
TW4B4221S	TM9Y120D20MP11	24.5	CF/CM64D	1400	42.0	33.4	15.25	12.75

COOLING CAPACITY - With High Efficiency Motor Furnaces¹ (Continued)

UNIT MODEL	FURNACE		COIL MODEL ²	COOLING				
	MODEL	WIDTH		RATED CFM	NET MBH		SEER	EER
					TOTAL	SENS.		
TW4B4221S	TMLV080C16MP12C	21.0	CF/CM/CU42C	1275	40.0	30.8	14.50	12.50
TW4B4221S	TMLV080C16MP12C	21.0	CF/CM/CU42D	1275	40.0	30.8	14.75	12.75
TW4B4221S	TMLV080C16MP12C	21.0	CF/CM/CU48C	1375	41.0	32.2	14.50	12.50
TW4B4221S	TMLV080C16MP12C	21.0	CF/CM/CU48D	1375	41.0	32.2	14.75	12.50
TW4B4221S	TMLV080C16MP12C	21.0	CF/CM/CU60C	1275	40.5	30.8	15.00	12.50
TW4B4221S	TMLV080C16MP12C	21.0	CF/CM/CU60D	1425	41.5	33.2	15.00	13.00
TW4B4221S	TMLV080C16MP12C	21.0	CF/CM64D	1375	42.0	33.0	15.00	12.50
TW4B4221S	TMLV100C16MP12C	21.0	CF/CM/CU42C	1275	40.0	30.8	14.50	12.50
TW4B4221S	TMLV100C16MP12C	21.0	CF/CM/CU42D	1275	40.0	30.8	14.75	12.75
TW4B4221S	TMLV100C16MP12C	21.0	CF/CM/CU48C	1375	41.0	32.2	14.50	12.50
TW4B4221S	TMLV100C16MP12C	21.0	CF/CM/CU48D	1375	41.0	32.2	14.75	12.50
TW4B4221S	TMLV100C16MP12C	21.0	CF/CM/CU60C	1275	40.5	30.8	15.00	12.50
TW4B4221S	TMLV100C16MP12C	21.0	CF/CM/CU60D	1425	41.5	33.2	15.00	13.00
TW4B4221S	TMLV100C16MP12C	21.0	CF/CM64D	1375	42.0	33.0	15.00	12.50
TW4B4221S	TMLV100C20MP12C	21.0	CF/CM/CU42C	1325	40.5	31.4	15.00	12.50
TW4B4221S	TMLV100C20MP12C	21.0	CF/CM/CU42D	1325	40.5	31.4	15.00	13.00
TW4B4221S	TMLV100C20MP12C	21.0	CF/CM/CU48C	1325	41.0	31.6	15.00	12.50
TW4B4221S	TMLV100C20MP12C	21.0	CF/CM/CU48D	1375	41.5	32.6	15.25	13.00
TW4B4221S	TMLV100C20MP12C	21.0	CF/CM/CU60C	1425	42.0	33.6	15.00	12.50
TW4B4221S	TMLV100C20MP12C	21.0	CF/CM/CU60D	1425	42.0	33.8	15.25	12.50
TW4B4221S	TMLV100C20MP12C	21.0	CF/CM64D	1375	42.0	33.0	15.25	12.75
TW4B4221S	TMLV120C20MP12C	21.0	CF/CM/CU42C	1325	40.5	31.4	15.00	12.50
TW4B4221S	TMLV120C20MP12C	21.0	CF/CM/CU42D	1325	40.5	31.4	15.00	13.00
TW4B4221S	TMLV120C20MP12C	21.0	CF/CM/CU48C	1325	41.0	31.6	15.00	12.50
TW4B4221S	TMLV120C20MP12C	21.0	CF/CM/CU48D	1375	41.5	32.6	15.25	13.00
TW4B4221S	TMLV120C20MP12C	21.0	CF/CM/CU60C	1425	42.0	33.6	15.00	12.50
TW4B4221S	TMLV120C20MP12C	21.0	CF/CM/CU60D	1425	42.0	33.8	15.25	12.50
TW4B4221S	TMLV120C20MP12C	21.0	CF/CM64D	1375	42.0	33.0	15.25	12.75
TW4B4221S	TMLX080B12MP11	17.5	CF42B	1175	40.0	29.4	14.50	12.50
TW4B4221S	TMLX080C16MP11	21.0	CF/CM/CU42C	1375	41.0	32.6	14.75	12.50
TW4B4221S	TMLX080C16MP11	21.0	CF/CM/CU42D	1175	39.5	29.0	14.75	12.50
TW4B4221S	TMLX080C16MP11	21.0	CF/CM/CU48C	1375	41.0	32.2	14.75	12.50
TW4B4221S	TMLX080C16MP11	21.0	CF/CM/CU48D	1400	41.5	32.8	14.75	12.50
TW4B4221S	TMLX080C16MP11	21.0	CF/CM/CU60C	1375	41.5	32.8	15.00	12.50
TW4B4221S	TMLX080C16MP11	21.0	CF/CM/CU60D	1400	41.5	33.0	15.00	12.50
TW4B4221S	TMLX080C16MP11	21.0	CF/CM42D	1175	39.5	29.0	14.75	12.50
TW4B4221S	TMLX080C16MP11	21.0	CF/CM64D	1375	42.0	33.0	15.00	12.50
TW4B4221S	TMLX100C16MP11	21.0	CF/CM/CU42C	1375	41.0	32.6	14.75	12.50
TW4B4221S	TMLX100C16MP11	21.0	CF/CM/CU42D	1175	39.5	29.0	14.75	12.50
TW4B4221S	TMLX100C16MP11	21.0	CF/CM/CU48C	1375	41.0	32.2	14.75	12.50
TW4B4221S	TMLX100C16MP11	21.0	CF/CM/CU48D	1400	41.5	32.8	14.75	12.50
TW4B4221S	TMLX100C16MP11	21.0	CF/CM/CU60C	1375	41.5	32.8	15.00	12.50
TW4B4221S	TMLX100C16MP11	21.0	CF/CM/CU60D	1400	41.5	33.0	15.00	12.50
TW4B4221S	TMLX100C16MP11	21.0	CF/CM42D	1175	39.5	29.0	14.75	12.50
TW4B4221S	TMLX100C16MP11	21.0	CF/CM64D	1375	42.0	33.0	15.00	12.50
TW4B4221S	TMLX100C20MP11	21.0	CF/CM/CU42C	1400	41.0	32.4	14.75	12.50
TW4B4221S	TMLX100C20MP11	21.0	CF/CM/CU42D	1250	40.0	30.6	15.25	12.75
TW4B4221S	TMLX100C20MP11	21.0	CF/CM/CU48C	1400	41.5	32.8	15.00	12.50
TW4B4221S	TMLX100C20MP11	21.0	CF/CM/CU48D	1425	41.5	33.0	15.25	12.75
TW4B4221S	TMLX100C20MP11	21.0	CF/CM/CU60C	1400	41.5	32.8	15.25	12.75
TW4B4221S	TMLX100C20MP11	21.0	CF/CM/CU60D	1425	42.0	33.8	15.25	12.75
TW4B4221S	TMLX100C20MP11	21.0	CF/CM42D	1250	40.0	30.6	15.25	12.75
TW4B4221S	TMLX100C20MP11	21.0	CF/CM64D	1400	42.0	33.4	15.50	12.75

COOLING CAPACITY - With High Efficiency Motor Furnaces¹ (Continued)

UNIT MODEL	FURNACE		COIL MODEL ²	COOLING				
	MODEL	WIDTH		RATED CFM	NET MBH		SEER	EER
					TOTAL	SENS.		
TW4B4221S	TMLX120C20MP11	21.0	CF/CM/CU42C	1400	41.0	32.4	14.75	12.50
TW4B4221S	TMLX120C20MP11	21.0	CF/CM/CU42D	1250	40.0	30.6	15.25	12.75
TW4B4221S	TMLX120C20MP11	21.0	CF/CM/CU48C	1400	41.5	32.8	15.00	12.50
TW4B4221S	TMLX120C20MP11	21.0	CF/CM/CU48D	1425	41.5	33.0	15.25	12.75
TW4B4221S	TMLX120C20MP11	21.0	CF/CM/CU60C	1400	41.5	32.8	15.25	12.75
TW4B4221S	TMLX120C20MP11	21.0	CF/CM/CU60D	1425	42.0	33.8	15.25	12.75
TW4B4221S	TMLX120C20MP11	21.0	CF/CM42D	1250	40.0	30.6	15.25	12.75
TW4B4221S	TMLX120C20MP11	21.0	CF/CM64D	1400	42.0	33.4	15.50	12.75
TW4B4221S	TP9C080B12MP12C	17.5	CF42B	1175	39.0	28.6	14.00	12.25
TW4B4221S	TP9C080B12MP13C	17.5	CF42B	1175	39.0	28.6	14.00	12.25
TW4B4221S	TP9C080C16MP13C	21.0	CF/CM/CU42C	1225	40.5	30.4	14.75	12.50
TW4B4221S	TP9C080C16MP13C	21.0	CF/CM/CU48C	1225	40.5	30.2	14.75	12.50
TW4B4221S	TP9C080C16MP13C	21.0	CF/CM/CU48D	1225	40.5	30.2	15.00	12.50
TW4B4221S	TP9C080C16MP13C	21.0	CF/CM/CU60C	1225	40.5	30.0	14.75	12.50
TW4B4221S	TP9C080C16MP13C	21.0	CF/CM/CU60D	1225	40.5	30.2	14.75	12.50
TW4B4221S	TP9C080C16MP13C	21.0	CF/CM42D	1225	40.5	30.4	14.75	12.50
TW4B4221S	TP9C080C16MP13C	21.0	CF/CM64D	1225	41.5	31.0	15.00	12.50
TW4B4221S	TP9C100C16MP12C	21.0	CF/CM/CU42C	1325	40.5	31.4	14.75	12.50
TW4B4221S	TP9C100C16MP12C	21.0	CF/CM/CU48C	1275	40.5	30.8	14.75	12.50
TW4B4221S	TP9C100C16MP12C	21.0	CF/CM/CU48D	1300	40.5	31.0	15.00	12.50
TW4B4221S	TP9C100C16MP12C	21.0	CF/CM/CU60C	1275	40.5	30.8	15.00	12.50
TW4B4221S	TP9C100C16MP12C	21.0	CF/CM/CU60D	1300	40.5	31.2	14.75	12.50
TW4B4221S	TP9C100C16MP12C	21.0	CF/CM64D	1275	41.0	31.4	15.00	12.50
TW4B4221S	TP9C100C16MP13C	21.0	CF/CM/CU42C	1325	40.5	31.4	14.75	12.50
TW4B4221S	TP9C100C16MP13C	21.0	CF/CM/CU42D	1300	40.0	31.0	14.75	12.75
TW4B4221S	TP9C100C16MP13C	21.0	CF/CM/CU48C	1275	40.5	30.8	14.75	12.50
TW4B4221S	TP9C100C16MP13C	21.0	CF/CM/CU48D	1300	40.5	31.0	15.00	12.50
TW4B4221S	TP9C100C16MP13C	21.0	CF/CM/CU60C	1275	40.5	30.8	15.00	12.50
TW4B4221S	TP9C100C16MP13C	21.0	CF/CM/CU60D	1300	40.5	31.2	14.75	12.50
TW4B4221S	TP9C100C16MP13C	21.0	CF/CM64D	1275	41.0	31.4	15.00	12.50
TW4B4221S	TP9C100C20MP12C	21.0	CF/CM/CU42C	1225	39.5	29.6	14.50	12.50
TW4B4221S	TP9C100C20MP12C	21.0	CF/CM/CU48C	1350	41.0	31.8	14.75	12.50
TW4B4221S	TP9C100C20MP12C	21.0	CF/CM/CU48D	1350	41.0	31.8	14.75	12.50
TW4B4221S	TP9C100C20MP12C	21.0	CF/CM/CU60C	1350	41.0	31.8	14.75	12.50
TW4B4221S	TP9C100C20MP12C	21.0	CF/CM/CU60D	1350	41.0	31.8	15.00	12.50
TW4B4221S	TP9C100C20MP12C	21.0	CF/CM64D	1350	41.5	32.4	15.00	12.50
TW4B4221S	TP9C100C20MP13C	21.0	CF/CM/CU42C	1225	39.5	29.6	14.50	12.50
TW4B4221S	TP9C100C20MP13C	21.0	CF/CM/CU42D	1350	40.5	31.8	14.75	12.75
TW4B4221S	TP9C100C20MP13C	21.0	CF/CM/CU48C	1350	41.0	31.8	14.75	12.50
TW4B4221S	TP9C100C20MP13C	21.0	CF/CM/CU48D	1350	41.0	31.8	14.75	12.50
TW4B4221S	TP9C100C20MP13C	21.0	CF/CM/CU60C	1350	41.0	31.8	14.75	12.50
TW4B4221S	TP9C100C20MP13C	21.0	CF/CM/CU60D	1350	41.0	31.8	15.00	12.50
TW4B4221S	TP9C100C20MP13C	21.0	CF/CM64D	1350	41.5	32.4	15.00	12.50
TW4B4221S	TP9C120D20MP12C	24.5	CF/CM42D	1400	41.0	32.4	15.00	12.50
TW4B4221S	TP9C120D20MP13C	24.5	CF/CM/CU42D	1400	41.0	32.4	15.00	12.50
TW4B4221S	TP9C120D20MP13C	24.5	CF/CM/CU48D	1400	41.5	32.8	15.00	12.50
TW4B4221S	TP9C120D20MP13C	24.5	CF/CM/CU60D	1400	41.5	32.8	15.25	12.50
TW4B4221S	TP9C120D20MP13C	24.5	CF/CM64D	1400	42.0	33.4	15.25	12.75
TW4B4221S	TPLC080C16MP12C	21.0	CF/CM/CU42C	1275	40.0	30.8	14.50	12.50
TW4B4221S	TPLC080C16MP12C	21.0	CF/CM/CU48C	1375	41.0	32.2	14.50	12.50
TW4B4221S	TPLC080C16MP12C	21.0	CF/CM/CU48D	1375	41.0	32.2	14.75	12.50
TW4B4221S	TPLC080C16MP12C	21.0	CF/CM/CU60C	1275	40.5	30.8	15.00	12.50
TW4B4221S	TPLC080C16MP12C	21.0	CF/CM64D	1375	42.0	33.0	15.00	12.50

COOLING CAPACITY - With High Efficiency Motor Furnaces¹ (Continued)

UNIT MODEL	FURNACE		COIL MODEL ²	COOLING				
	MODEL	WIDTH		RATED CFM	NET MBH		SEER	EER
					TOTAL	SENS.		
TW4B4221S	TPLC080C16MP13C	21.0	CF/CM/CU42C	1275	40.0	30.8	14.50	12.50
TW4B4221S	TPLC080C16MP13C	21.0	CF/CM/CU42D	1275	40.0	30.8	14.75	12.75
TW4B4221S	TPLC080C16MP13C	21.0	CF/CM/CU48C	1375	41.0	32.2	14.50	12.50
TW4B4221S	TPLC080C16MP13C	21.0	CF/CM/CU48D	1375	41.0	32.2	14.75	12.50
TW4B4221S	TPLC080C16MP13C	21.0	CF/CM/CU60C	1275	40.5	30.8	15.00	12.50
TW4B4221S	TPLC080C16MP13C	21.0	CF/CM/CU60D	1425	41.5	33.2	15.00	13.00
TW4B4221S	TPLC080C16MP13C	21.0	CF/CM64D	1375	42.0	33.0	15.00	12.50
TW4B4221S	TPLC100C16MP12C	21.0	CF/CM/CU42C	1275	40.0	30.8	14.50	12.50
TW4B4221S	TPLC100C16MP12C	21.0	CF/CM/CU48C	1375	41.0	32.2	14.50	12.50
TW4B4221S	TPLC100C16MP12C	21.0	CF/CM/CU48D	1375	41.0	32.2	14.75	12.50
TW4B4221S	TPLC100C16MP12C	21.0	CF/CM/CU60C	1275	40.5	30.8	15.00	12.50
TW4B4221S	TPLC100C16MP12C	21.0	CF/CM64D	1375	42.0	33.0	15.00	12.50
TW4B4221S	TPLC100C16MP13C	21.0	CF/CM/CU42C	1275	40.0	30.8	14.50	12.50
TW4B4221S	TPLC100C16MP13C	21.0	CF/CM/CU42D	1275	40.0	30.8	14.75	12.75
TW4B4221S	TPLC100C16MP13C	21.0	CF/CM/CU48C	1375	41.0	32.2	14.50	12.50
TW4B4221S	TPLC100C16MP13C	21.0	CF/CM/CU48D	1375	41.0	32.2	14.75	12.50
TW4B4221S	TPLC100C16MP13C	21.0	CF/CM/CU60C	1275	40.5	30.8	15.00	12.50
TW4B4221S	TPLC100C16MP13C	21.0	CF/CM64D	1375	42.0	33.0	15.00	12.50
TW4B4221S	TPLC100C16MP13C	21.0	CF/CM/CU42C	1275	40.0	30.8	14.50	12.50
TW4B4221S	TPLC100C16MP13C	21.0	CF/CM/CU42D	1275	40.0	30.8	14.75	12.75
TW4B4221S	TPLC100C16MP13C	21.0	CF/CM/CU48C	1375	41.0	32.2	14.50	12.50
TW4B4221S	TPLC100C16MP13C	21.0	CF/CM/CU48D	1375	41.0	32.2	14.75	12.50
TW4B4221S	TPLC100C16MP13C	21.0	CF/CM/CU60C	1275	40.5	30.8	15.00	12.50
TW4B4221S	TPLC100C16MP13C	21.0	CF/CM/CU60D	1425	41.5	33.2	15.00	13.00
TW4B4221S	TPLC100C16MP13C	21.0	CF/CM64D	1375	42.0	33.0	15.00	12.50
TW4B4221S	TPLC100C20MP13C	21.0	CF/CM/CU42C	1325	40.5	31.4	15.00	12.50
TW4B4221S	TPLC100C20MP13C	21.0	CF/CM/CU42D	1325	40.5	31.4	15.00	13.00
TW4B4221S	TPLC100C20MP13C	21.0	CF/CM/CU48C	1325	41.0	31.6	15.00	12.50
TW4B4221S	TPLC100C20MP13C	21.0	CF/CM/CU48D	1375	41.5	32.6	15.25	13.00
TW4B4221S	TPLC100C20MP13C	21.0	CF/CM/CU60C	1425	42.0	33.6	15.00	12.50
TW4B4221S	TPLC100C20MP13C	21.0	CF/CM/CU60D	1425	42.0	33.8	15.25	12.50
TW4B4221S	TPLC100C20MP13C	21.0	CF/CM64D	1375	42.0	33.0	15.25	12.75
TW4B4221S	TPLC120C20MP13C	21.0	CF/CM/CU42C	1325	40.5	31.4	15.00	12.50
TW4B4221S	TPLC120C20MP13C	21.0	CF/CM/CU42D	1325	40.5	31.4	15.00	13.00
TW4B4221S	TPLC120C20MP13C	21.0	CF/CM/CU48C	1325	41.0	31.6	15.00	12.50
TW4B4221S	TPLC120C20MP13C	21.0	CF/CM/CU48D	1375	41.5	32.6	15.25	13.00
TW4B4221S	TPLC120C20MP13C	21.0	CF/CM/CU60C	1425	42.0	33.6	15.00	12.50
TW4B4221S	TPLC120C20MP13C	21.0	CF/CM/CU60D	1425	42.0	33.8	15.25	12.50
TW4B4221S	TPLC120C20MP13C	21.0	CF/CM64D	1375	42.0	33.0	15.25	12.75
TW4B4221S	CP9C080B12MP12C	17.5	CF42B	1175	39.0	28.6	14.00	12.25
TW4B4221S	CP9C080B12MP13C	17.5	CF42B	1175	39.0	28.6	14.00	12.25
TW4B4221S	CP9C080C16MP13C	21.0	CF/CM/CU42C	1225	40.5	30.4	14.75	12.50
TW4B4221S	CP9C080C16MP13C	21.0	CF/CM/CU48C	1225	40.5	30.2	14.75	12.50
TW4B4221S	CP9C080C16MP13C	21.0	CF/CM/CU48D	1225	40.5	30.2	15.00	12.50
TW4B4221S	CP9C080C16MP13C	21.0	CF/CM/CU60C	1225	40.5	30.0	14.75	12.50
TW4B4221S	CP9C080C16MP13C	21.0	CF/CM/CU60D	1225	40.5	30.2	14.75	12.50
TW4B4221S	CP9C080C16MP13C	21.0	CF/CM42D	1225	40.5	30.4	14.75	12.50
TW4B4221S	CP9C080C16MP13C	21.0	CF/CM64D	1225	41.5	31.0	15.00	12.50
TW4B4221S	CP9C100C16MP12C	21.0	CF/CM/CU42C	1325	40.5	31.4	14.75	12.50
TW4B4221S	CP9C100C16MP12C	21.0	CF/CM/CU48C	1275	40.5	30.8	14.75	12.50
TW4B4221S	CP9C100C16MP12C	21.0	CF/CM/CU48D	1300	40.5	31.0	15.00	12.50
TW4B4221S	CP9C100C16MP12C	21.0	CF/CM/CU60C	1275	40.5	30.8	15.00	12.50
TW4B4221S	CP9C100C16MP12C	21.0	CF/CM/CU60D	1300	40.5	31.2	14.75	12.50
TW4B4221S	CP9C100C16MP12C	21.0	CF/CM64D	1275	41.0	31.4	15.00	12.50
TW4B4221S	CP9C100C16MP13C	21.0	CF/CM/CU42C	1325	40.5	31.4	14.75	12.50
TW4B4221S	CP9C100C16MP13C	21.0	CF/CM/CU42D	1300	40.0	31.0	14.75	12.75
TW4B4221S	CP9C100C16MP13C	21.0	CF/CM/CU48C	1275	40.5	30.8	14.75	12.50
TW4B4221S	CP9C100C16MP13C	21.0	CF/CM/CU48D	1300	40.5	31.0	15.00	12.50
TW4B4221S	CP9C100C16MP13C	21.0	CF/CM/CU60C	1275	40.5	30.8	15.00	12.50

COOLING CAPACITY - With High Efficiency Motor Furnaces¹ (Continued)

UNIT MODEL	FURNACE		COIL MODEL ²	COOLING				
	MODEL	WIDTH		RATED CFM	NET MBH		SEER	EER
					TOTAL	SENS.		
TW4B4221S	CP9C100C16MP13C	21.0	CF/CM/CU60D	1300	40.5	31.2	14.75	12.50
TW4B4221S	CP9C100C16MP13C	21.0	CF/CM64D	1275	41.0	31.4	15.00	12.50
TW4B4221S	CP9C100C20MP12C	21.0	CF/CM/CU42C	1225	39.5	29.6	14.50	12.50
TW4B4221S	CP9C100C20MP12C	21.0	CF/CM/CU48C	1350	41.0	31.8	14.75	12.50
TW4B4221S	CP9C100C20MP12C	21.0	CF/CM/CU48D	1350	41.0	31.8	14.75	12.50
TW4B4221S	CP9C100C20MP12C	21.0	CF/CM/CU60C	1350	41.0	31.8	14.75	12.50
TW4B4221S	CP9C100C20MP12C	21.0	CF/CM/CU60D	1350	41.0	31.8	15.00	12.50
TW4B4221S	CP9C100C20MP12C	21.0	CF/CM64D	1350	41.5	32.4	15.00	12.50
TW4B4221S	CP9C100C20MP13C	21.0	CF/CM/CU42C	1225	39.5	29.6	14.50	12.50
TW4B4221S	CP9C100C20MP13C	21.0	CF/CM/CU42D	1350	40.5	31.8	14.75	12.75
TW4B4221S	CP9C100C20MP13C	21.0	CF/CM/CU48C	1350	41.0	31.8	14.75	12.50
TW4B4221S	CP9C100C20MP13C	21.0	CF/CM/CU48D	1350	41.0	31.8	14.75	12.50
TW4B4221S	CP9C100C20MP13C	21.0	CF/CM/CU60C	1350	41.0	31.8	14.75	12.50
TW4B4221S	CP9C100C20MP13C	21.0	CF/CM/CU60D	1350	41.0	31.8	15.00	12.50
TW4B4221S	CP9C100C20MP13C	21.0	CF/CM64D	1350	41.5	32.4	15.00	12.50
TW4B4221S	CP9C120D20MP12C	24.5	CF/CM/CU48D	1400	41.5	32.8	15.00	12.50
TW4B4221S	CP9C120D20MP12C	24.5	CF/CM/CU60D	1400	41.5	32.8	15.25	12.50
TW4B4221S	CP9C120D20MP12C	24.5	CF/CM42D	1400	41.0	32.4	15.00	12.50
TW4B4221S	CP9C120D20MP12C	24.5	CF/CM64D	1400	42.0	33.4	15.25	12.75
TW4B4221S	CP9C120D20MP13C	24.5	CF/CM/CU42D	1400	41.0	32.4	15.00	12.50
TW4B4221S	CP9C120D20MP13C	24.5	CF/CM/CU48D	1400	41.5	32.8	15.00	12.50
TW4B4221S	CP9C120D20MP13C	24.5	CF/CM/CU60D	1400	41.5	32.8	15.25	12.50
TW4B4221S	CP9C120D20MP13C	24.5	CF/CM64D	1400	42.0	33.4	15.25	12.75
TW4B4221S	CPLC080C16MP12C	21.0	CF/CM/CU42C	1275	40.0	30.8	14.50	12.50
TW4B4221S	CPLC080C16MP12C	21.0	CF/CM/CU48C	1375	41.0	32.2	14.50	12.50
TW4B4221S	CPLC080C16MP12C	21.0	CF/CM/CU48D	1375	41.0	32.2	14.75	12.50
TW4B4221S	CPLC080C16MP12C	21.0	CF/CM/CU60C	1275	40.5	30.8	15.00	12.50
TW4B4221S	CPLC080C16MP12C	21.0	CF/CM64D	1375	42.0	33.0	15.00	12.50
TW4B4221S	CPLC080C16MP13C	21.0	CF/CM/CU42C	1275	40.0	30.8	14.50	12.50
TW4B4221S	CPLC080C16MP13C	21.0	CF/CM/CU42D	1275	40.0	30.8	14.75	12.75
TW4B4221S	CPLC080C16MP13C	21.0	CF/CM/CU48C	1375	41.0	32.2	14.50	12.50
TW4B4221S	CPLC080C16MP13C	21.0	CF/CM/CU48D	1375	41.0	32.2	14.75	12.50
TW4B4221S	CPLC080C16MP13C	21.0	CF/CM/CU60C	1275	40.5	30.8	15.00	12.50
TW4B4221S	CPLC080C16MP13C	21.0	CF/CM/CU60D	1425	41.5	33.2	15.00	13.00
TW4B4221S	CPLC080C16MP13C	21.0	CF/CM64D	1375	42.0	33.0	15.00	12.50
TW4B4221S	CPLC100C16MP12C	21.0	CF/CM/CU42C	1275	40.0	30.8	14.50	12.50
TW4B4221S	CPLC100C16MP12C	21.0	CF/CM/CU48C	1375	41.0	32.2	14.50	12.50
TW4B4221S	CPLC100C16MP12C	21.0	CF/CM/CU48D	1375	41.0	32.2	14.75	12.50
TW4B4221S	CPLC100C16MP12C	21.0	CF/CM/CU60C	1275	40.5	30.8	15.00	12.50
TW4B4221S	CPLC100C16MP12C	21.0	CF/CM64D	1375	42.0	33.0	15.00	12.50
TW4B4221S	CPLC100C16MP13C	21.0	CF/CM/CU42C	1275	40.0	30.8	14.50	12.50
TW4B4221S	CPLC100C16MP13C	21.0	CF/CM/CU42D	1275	40.0	30.8	14.75	12.75
TW4B4221S	CPLC100C16MP13C	21.0	CF/CM/CU48C	1375	41.0	32.2	14.50	12.50
TW4B4221S	CPLC100C16MP13C	21.0	CF/CM/CU48D	1375	41.0	32.2	14.75	12.50
TW4B4221S	CPLC100C16MP13C	21.0	CF/CM/CU60C	1275	40.5	30.8	15.00	12.50
TW4B4221S	CPLC100C16MP13C	21.0	CF/CM/CU60D	1425	41.5	33.2	15.00	13.00
TW4B4221S	CPLC100C16MP13C	21.0	CF/CM64D	1375	42.0	33.0	15.00	12.50
TW4B4221S	CPLC100C20MP12C	21.0	CF/CM/CU42C	1325	40.5	31.4	15.00	12.50
TW4B4221S	CPLC100C20MP12C	21.0	CF/CM/CU48C	1325	41.0	31.6	15.00	12.50
TW4B4221S	CPLC100C20MP12C	21.0	CF/CM/CU60C	1425	42.0	33.6	15.00	12.50
TW4B4221S	CPLC100C20MP12C	21.0	CF/CM/CU60D	1425	42.0	33.8	15.25	12.50
TW4B4221S	CPLC100C20MP12C	21.0	CF/CM64D	1375	42.0	33.0	15.25	12.75
TW4B4221S	CPLC100C20MP13C	21.0	CF/CM/CU42C	1325	40.5	31.4	15.00	12.50

COOLING CAPACITY - With High Efficiency Motor Furnaces¹ (Continued)

UNIT MODEL	FURNACE		COIL MODEL ²	COOLING				
	MODEL	WIDTH		RATED CFM	NET MBH		SEER	EER
					TOTAL	SENS.		
TW4B4221S	CPLC100C20MP13C	21.0	CF/CM/CU42D	1325	40.5	31.4	15.00	13.00
TW4B4221S	CPLC100C20MP13C	21.0	CF/CM/CU48C	1325	41.0	31.6	15.00	12.50
TW4B4221S	CPLC100C20MP13C	21.0	CF/CM/CU48D	1375	41.5	32.6	15.25	13.00
TW4B4221S	CPLC100C20MP13C	21.0	CF/CM/CU60C	1425	42.0	33.6	15.00	12.50
TW4B4221S	CPLC100C20MP13C	21.0	CF/CM/CU60D	1425	42.0	33.8	15.25	12.50
TW4B4221S	CPLC100C20MP13C	21.0	CF/CM64D	1375	42.0	33.0	15.25	12.75
TW4B4221S	CPLC120C20MP12C	21.0	CF/CM/CU42C	1325	40.5	31.4	15.00	12.50
TW4B4221S	CPLC120C20MP12C	21.0	CF/CM/CU48C	1325	41.0	31.6	15.00	12.50
TW4B4221S	CPLC120C20MP12C	21.0	CF/CM/CU60C	1425	42.0	33.6	15.00	12.50
TW4B4221S	CPLC120C20MP12C	21.0	CF/CM/CU60D	1425	42.0	33.8	15.25	12.50
TW4B4221S	CPLC120C20MP12C	21.0	CF/CM64D	1375	42.0	33.0	15.25	12.75
TW4B4221S	CPLC120C20MP13C	21.0	CF/CM/CU42C	1325	40.5	31.4	15.00	12.50
TW4B4221S	CPLC120C20MP13C	21.0	CF/CM/CU42D	1325	40.5	31.4	15.00	13.00
TW4B4221S	CPLC120C20MP13C	21.0	CF/CM/CU48C	1325	41.0	31.6	15.00	12.50
TW4B4221S	CPLC120C20MP13C	21.0	CF/CM/CU48D	1375	41.5	32.6	15.25	13.00
TW4B4221S	CPLC120C20MP13C	21.0	CF/CM/CU60C	1425	42.0	33.6	15.00	12.50
TW4B4221S	CPLC120C20MP13C	21.0	CF/CM/CU60D	1425	42.0	33.8	15.25	12.50
TW4B4221S	CPLC120C20MP13C	21.0	CF/CM64D	1375	42.0	33.0	15.25	12.75
TW4B4821S	TL8E080C16UH11	21.0	CF/CM/CU48C	1400	48.0	35.0	15.00	12.50
TW4B4821S	TL8E080C16UH11	21.0	CF/CM/CU48D	1400	48.0	35.0	15.00	12.25
TW4B4821S	TL8E080C16UH11	21.0	CF/CM/CU60C	1375	48.0	35.0	14.75	12.25
TW4B4821S	TL8E080C16UH11	21.0	CF/CM/CU60D	1400	48.0	35.2	15.00	12.50
TW4B4821S	TL8E080C16UH11	21.0	CF/CM64D	1400	48.0	35.0	15.25	12.50
TW4B4821S	TL8E100C20UH11	21.0	CF/CM/CU48C	1400	48.0	35.0	15.25	12.50
TW4B4821S	TL8E100C20UH11	21.0	CF/CM/CU48D	1425	48.0	35.2	15.25	12.50
TW4B4821S	TL8E100C20UH11	21.0	CF/CM/CU60C	1400	48.0	35.0	15.25	12.50
TW4B4821S	TL8E100C20UH11	21.0	CF/CM/CU60D	1425	48.0	35.6	15.25	12.50
TW4B4821S	TL8E100C20UH11	21.0	CF/CM64D	1400	48.0	35.2	15.50	12.75
TW4B4821S	TL9E080C16UH11	21.0	CF/CM/CU48C	1400	48.0	35.0	14.75	12.25
TW4B4821S	TL9E080C16UH11	21.0	CF/CM/CU48D	1400	48.0	35.0	14.75	12.25
TW4B4821S	TL9E080C16UH11	21.0	CF/CM/CU60C	1400	48.0	35.0	14.50	12.25
TW4B4821S	TL9E080C16UH11	21.0	CF/CM/CU60D	1425	48.0	35.6	14.75	12.25
TW4B4821S	TL9E080C16UH11	21.0	CF/CM64D	1400	48.0	35.2	15.00	12.50
TW4B4821S	TL9E100C20UH11	21.0	CF/CM/CU48C	1400	48.0	35.0	15.25	12.50
TW4B4821S	TL9E100C20UH11	21.0	CF/CM/CU48D	1425	48.0	35.2	15.25	12.50
TW4B4821S	TL9E100C20UH11	21.0	CF/CM/CU60C	1400	48.0	35.0	15.00	12.50
TW4B4821S	TL9E100C20UH11	21.0	CF/CM/CU60D	1425	48.0	35.4	15.25	12.50
TW4B4821S	TL9E100C20UH11	21.0	CF/CM64D	1400	48.0	35.2	15.50	12.75
TW4B4821S	TM8E080B12MP11	17.5	CF/CM/CU48C	1325	48.0	34.6	14.25	12.00
TW4B4821S	TM8E080C16MP11	21.0	CF/CM/CU48C	1575	47.5	34.8	14.00	11.75
TW4B4821S	TM8E080C16MP11	21.0	CF/CM/CU48D	1600	48.0	35.4	14.00	11.75
TW4B4821S	TM8E080C16MP11	21.0	CF/CM/CU60C	1575	48.0	36.4	14.50	12.25
TW4B4821S	TM8E080C16MP11	21.0	CF/CM/CU60D	1600	48.0	36.8	14.50	12.25
TW4B4821S	TM8E080C16MP11	21.0	CF/CM64D	1575	48.0	36.6	14.75	12.25
TW4B4821S	TM8E080C20MP11	21.0	CF/CM/CU48C	1450	48.0	35.6	15.25	12.50
TW4B4821S	TM8E080C20MP11	21.0	CF/CM/CU48D	1475	48.0	35.4	15.25	12.50
TW4B4821S	TM8E080C20MP11	21.0	CF/CM/CU60C	1450	48.0	35.4	15.25	12.50
TW4B4821S	TM8E080C20MP11	21.0	CF/CM/CU60D	1475	48.0	35.8	15.25	12.50
TW4B4821S	TM8E080C20MP11	21.0	CF/CM64D	1450	48.0	35.6	15.50	12.75
TW4B4821S	TM8E100C16MP11	21.0	CF/CM/CU48C	1300	48.0	33.8	15.25	12.50
TW4B4821S	TM8E100C16MP11	21.0	CF/CM/CU48D	1300	48.0	33.8	15.25	12.50
TW4B4821S	TM8E100C16MP11	21.0	CF/CM/CU60C	1575	48.0	36.4	14.50	12.25
TW4B4821S	TM8E100C16MP11	21.0	CF/CM/CU60D	1300	48.0	34.2	15.25	12.50

COOLING CAPACITY - With High Efficiency Motor Furnaces¹ (Continued)

UNIT MODEL	FURNACE		COIL MODEL ²	COOLING				
	MODEL	WIDTH		RATED CFM	NET MBH		SEER	EER
					TOTAL	SENS.		
TW4B4821S	TM8E100C16MP11	21.0	CF/CM64D	1300	48.0	34.2	15.50	12.75
TW4B4821S	TM8E100C20MP11	21.0	CF/CM/CU48C	1425	48.0	35.2	15.25	12.50
TW4B4821S	TM8E100C20MP11	21.0	CF/CM/CU48D	1450	48.0	35.6	15.25	12.50
TW4B4821S	TM8E100C20MP11	21.0	CF/CM/CU60C	1425	48.0	35.0	15.00	12.50
TW4B4821S	TM8E100C20MP11	21.0	CF/CM/CU60D	1450	48.0	35.6	15.25	12.50
TW4B4821S	TM8E100C20MP11	21.0	CF/CM64D	1425	48.0	35.2	15.50	12.75
TW4B4821S	TM8E120C16MP11	21.0	CF/CM/CU48C	1300	48.0	33.8	15.25	12.50
TW4B4821S	TM8E120C16MP11	21.0	CF/CM/CU48D	1300	48.0	33.8	15.25	12.50
TW4B4821S	TM8E120C16MP11	21.0	CF/CM/CU60C	1300	48.0	34.0	15.25	12.50
TW4B4821S	TM8E120C16MP11	21.0	CF/CM/CU60D	1325	48.0	34.6	15.25	12.50
TW4B4821S	TM8E120C16MP11	21.0	CF/CM64D	1300	48.0	34.2	15.50	12.75
TW4B4821S	TM8E120C20MP11	21.0	CF/CM/CU48C	1425	48.0	35.2	15.25	12.50
TW4B4821S	TM8E120C20MP11	21.0	CF/CM/CU48D	1450	48.0	35.4	15.25	12.50
TW4B4821S	TM8E120C20MP11	21.0	CF/CM/CU60C	1425	48.0	35.0	15.25	12.50
TW4B4821S	TM8E120C20MP11	21.0	CF/CM/CU60D	1300	48.0	34.4	15.50	12.75
TW4B4821S	TM8E120C20MP11	21.0	CF/CM64D	1425	48.0	35.2	15.50	12.75
TW4B4821S	TM8E130D20MP11	24.5	CF/CM/CU48D	1425	48.0	35.2	15.50	12.75
TW4B4821S	TM8E130D20MP11	24.5	CF/CM/CU60D	1450	48.0	35.6	15.50	12.75
TW4B4821S	TM8E130D20MP11	24.5	CF/CM64D	1425	48.0	35.2	15.75	13.00
TW4B4821S	TM8V080C16MP11C	21.0	CF/CM/CU48C	1325	48.0	33.4	15.00	12.50
TW4B4821S	TM8V080C16MP11C	21.0	CF/CM/CU48D	1300	48.0	33.4	15.25	12.50
TW4B4821S	TM8V080C16MP11C	21.0	CF/CM/CU60C	1325	48.0	33.6	15.50	12.75
TW4B4821S	TM8V080C16MP11C	21.0	CF/CM/CU60D	1325	48.0	33.6	15.50	12.75
TW4B4821S	TM8V080C16MP11C	21.0	CF/CM64D	1400	48.0	34.4	15.50	12.75
TW4B4821S	TM8V080C16MP12C	21.0	CF/CM/CU48C	1425	47.0	34.4	15.00	12.50
TW4B4821S	TM8V080C16MP12C	21.0	CF/CM/CU48D	1425	48.0	35.2	15.00	12.50
TW4B4821S	TM8V080C16MP12C	21.0	CF/CM/CU60C	1425	47.0	34.8	15.00	12.50
TW4B4821S	TM8V080C16MP12C	21.0	CF/CM/CU60D	1425	47.0	34.8	15.25	12.75
TW4B4821S	TM8V080C16MP12C	21.0	CF/CM64D	1425	48.0	35.4	15.25	12.75
TW4B4821S	TM8V100C16MP11C	21.0	CF/CM/CU48C	1325	48.0	33.4	15.00	12.50
TW4B4821S	TM8V100C16MP11C	21.0	CF/CM/CU48D	1300	48.0	33.4	15.25	12.50
TW4B4821S	TM8V100C16MP11C	21.0	CF/CM/CU60C	1325	48.0	33.6	15.50	12.75
TW4B4821S	TM8V100C16MP11C	21.0	CF/CM/CU60D	1325	48.0	33.6	15.50	12.75
TW4B4821S	TM8V100C16MP11C	21.0	CF/CM64D	1400	48.0	34.4	15.50	12.75
TW4B4821S	TM8V100C16MP12C	21.0	CF/CM/CU48C	1425	47.0	34.4	15.00	12.50
TW4B4821S	TM8V100C16MP12C	21.0	CF/CM/CU48D	1425	48.0	35.2	15.00	12.50
TW4B4821S	TM8V100C16MP12C	21.0	CF/CM/CU60C	1425	47.0	34.8	15.00	12.50
TW4B4821S	TM8V100C16MP12C	21.0	CF/CM/CU60D	1425	47.0	34.8	15.25	12.75
TW4B4821S	TM8V100C16MP12C	21.0	CF/CM64D	1425	48.0	35.4	15.25	12.75
TW4B4821S	TM8V100C20MP11C	21.0	CF/CM/CU48C	1300	48.0	33.4	15.25	12.50
TW4B4821S	TM8V100C20MP11C	21.0	CF/CM/CU48D	1650	48.0	35.2	15.75	12.75
TW4B4821S	TM8V100C20MP11C	21.0	CF/CM/CU60C	1400	48.0	34.4	15.50	12.75
TW4B4821S	TM8V100C20MP11C	21.0	CF/CM/CU60D	1350	48.0	33.8	15.25	12.50
TW4B4821S	TM8V100C20MP11C	21.0	CF/CM64D	1425	48.0	34.8	15.50	12.75
TW4B4821S	TM8V100C20MP12C	21.0	CF/CM/CU48C	1425	47.0	34.6	15.00	12.50
TW4B4821S	TM8V100C20MP12C	21.0	CF/CM/CU48D	1375	48.0	34.6	15.50	12.75
TW4B4821S	TM8V100C20MP12C	21.0	CF/CM/CU60C	1375	47.5	34.6	15.25	12.75
TW4B4821S	TM8V100C20MP12C	21.0	CF/CM/CU60D	1475	48.0	35.8	15.00	12.50
TW4B4821S	TM8V100C20MP12C	21.0	CF/CM64D	1425	47.5	35.0	15.25	12.50
TW4B4821S	TM8V120C20MP12C	21.0	CF/CM/CU48C	1425	47.0	34.6	15.00	12.50
TW4B4821S	TM8V120C20MP12C	21.0	CF/CM/CU48D	1375	48.0	34.6	15.50	12.75
TW4B4821S	TM8V120C20MP12C	21.0	CF/CM/CU60C	1375	47.5	34.6	15.25	12.75
TW4B4821S	TM8V120C20MP12C	21.0	CF/CM/CU60D	1475	48.0	35.8	15.00	12.50

COOLING CAPACITY - With High Efficiency Motor Furnaces¹ (Continued)

UNIT MODEL	FURNACE		COIL MODEL ²	COOLING				
	MODEL	WIDTH		RATED CFM	NET MBH		SEER	EER
					TOTAL	SENS.		
TW4B4821S	TM8V120C20MP12C	21.0	CF/CM64D	1425	47.5	35.0	15.25	12.50
TW4B4821S	TM8X080C16MP11	21.0	CF/CM/CU48C	1400	48.0	34.8	15.25	12.50
TW4B4821S	TM8X080C16MP11	21.0	CF/CM/CU48D	1425	48.0	34.2	15.25	12.50
TW4B4821S	TM8X080C16MP11	21.0	CF/CM/CU60C	1400	48.0	34.4	15.25	12.50
TW4B4821S	TM8X080C16MP11	21.0	CF/CM/CU60D	1425	48.0	34.6	15.50	12.75
TW4B4821S	TM8X080C16MP11	21.0	CF/CM64D	1400	48.0	34.6	15.50	12.75
TW4B4821S	TM8X100C16MP11	21.0	CF/CM/CU48C	1400	48.0	34.8	15.25	12.50
TW4B4821S	TM8X100C16MP11	21.0	CF/CM/CU48D	1425	48.0	34.2	15.25	12.50
TW4B4821S	TM8X100C16MP11	21.0	CF/CM/CU60C	1400	48.0	34.4	15.25	12.50
TW4B4821S	TM8X100C16MP11	21.0	CF/CM/CU60D	1425	48.0	34.6	15.50	12.75
TW4B4821S	TM8X100C16MP11	21.0	CF/CM64D	1400	48.0	34.6	15.50	12.75
TW4B4821S	TM8X100C20MP11	21.0	CF/CM/CU48C	1425	48.0	34.4	15.50	12.75
TW4B4821S	TM8X100C20MP11	21.0	CF/CM/CU48D	1300	48.0	33.6	15.75	13.00
TW4B4821S	TM8X100C20MP11	21.0	CF/CM/CU60C	1450	48.0	35.2	15.50	12.75
TW4B4821S	TM8X100C20MP11	21.0	CF/CM/CU60D	1475	48.0	35.2	15.75	13.00
TW4B4821S	TM8X100C20MP11	21.0	CF/CM64D	1450	48.0	34.8	15.75	13.00
TW4B4821S	TM8X120C20MP11	21.0	CF/CM/CU48C	1425	48.0	34.4	15.50	12.75
TW4B4821S	TM8X120C20MP11	21.0	CF/CM/CU48D	1300	48.0	33.6	15.75	13.00
TW4B4821S	TM8X120C20MP11	21.0	CF/CM/CU60C	1450	48.0	35.2	15.50	12.75
TW4B4821S	TM8X120C20MP11	21.0	CF/CM/CU60D	1475	48.0	35.2	15.75	13.00
TW4B4821S	TM8X120C20MP11	21.0	CF/CM64D	1450	48.0	34.8	15.75	13.00
TW4B4821S	TM8Y080C16MP11	21.0	CF/CM/CU48C	1400	48.0	34.8	15.25	12.50
TW4B4821S	TM8Y080C16MP11	21.0	CF/CM/CU48D	1425	48.0	34.2	15.25	12.50
TW4B4821S	TM8Y080C16MP11	21.0	CF/CM/CU60C	1400	48.0	34.4	15.25	12.50
TW4B4821S	TM8Y080C16MP11	21.0	CF/CM/CU60D	1425	48.0	34.6	15.50	12.75
TW4B4821S	TM8Y080C16MP11	21.0	CF/CM64D	1400	48.0	34.6	15.50	12.75
TW4B4821S	TM8Y100C16MP11	21.0	CF/CM/CU48C	1400	48.0	34.8	15.25	12.50
TW4B4821S	TM8Y100C16MP11	21.0	CF/CM/CU48D	1425	48.0	34.2	15.25	12.50
TW4B4821S	TM8Y100C16MP11	21.0	CF/CM/CU60C	1400	48.0	34.4	15.25	12.50
TW4B4821S	TM8Y100C16MP11	21.0	CF/CM/CU60D	1425	48.0	34.6	15.50	12.75
TW4B4821S	TM8Y100C16MP11	21.0	CF/CM64D	1400	48.0	34.6	15.50	12.75
TW4B4821S	TM8Y100C20MP11	21.0	CF/CM/CU48C	1425	48.0	34.4	15.50	12.75
TW4B4821S	TM8Y100C20MP11	21.0	CF/CM/CU48D	1300	48.0	33.6	15.75	13.00
TW4B4821S	TM8Y100C20MP11	21.0	CF/CM/CU60C	1450	48.0	35.2	15.50	12.75
TW4B4821S	TM8Y100C20MP11	21.0	CF/CM/CU60D	1475	48.0	35.2	15.75	13.00
TW4B4821S	TM8Y100C20MP11	21.0	CF/CM64D	1450	48.0	34.8	15.75	13.00
TW4B4821S	TM8Y120C20MP11	21.0	CF/CM/CU48C	1425	48.0	34.4	15.50	12.75
TW4B4821S	TM8Y120C20MP11	21.0	CF/CM/CU48D	1300	48.0	33.6	15.75	13.00
TW4B4821S	TM8Y120C20MP11	21.0	CF/CM/CU60C	1450	48.0	35.2	15.50	12.75
TW4B4821S	TM8Y120C20MP11	21.0	CF/CM/CU60D	1475	48.0	35.2	15.75	13.00
TW4B4821S	TM8Y120C20MP11	21.0	CF/CM64D	1450	48.0	34.8	15.75	13.00
TW4B4821S	TM9E080B12MP12	17.5	CF/CM/CU48C	1325	48.0	34.6	14.25	12.00
TW4B4821S	TM9E080B12MP12	17.5	CF/CM/CU60C	1325	47.5	34.0	14.25	11.75
TW4B4821S	TM9E080C16MP11	21.0	CF/CM/CU48D	1350	48.0	33.6	15.00	12.50
TW4B4821S	TM9E080C16MP11	21.0	CF/CM/CU60C	1325	48.0	33.8	15.25	12.50
TW4B4821S	TM9E080C16MP11	21.0	CF/CM/CU60D	1325	48.0	33.8	15.25	12.50
TW4B4821S	TM9E080C16MP11	21.0	CF/CM64D	1350	48.0	33.4	15.50	12.75
TW4B4821S	TM9E080C20MP12	21.0	CF/CM/CU48C	1400	48.0	35.0	15.25	12.50
TW4B4821S	TM9E080C20MP12	21.0	CF/CM/CU48D	1425	48.0	35.2	15.25	12.50
TW4B4821S	TM9E080C20MP12	21.0	CF/CM/CU60C	1400	48.0	35.0	15.00	12.50
TW4B4821S	TM9E080C20MP12	21.0	CF/CM/CU60D	1425	48.0	35.4	15.25	12.50
TW4B4821S	TM9E080C20MP12	21.0	CF/CM64D	1400	48.0	35.2	15.50	12.75
TW4B4821S	TM9E100C16MP11	21.0	CF/CM/CU48C	1325	48.0	33.6	15.00	12.50

COOLING CAPACITY - With High Efficiency Motor Furnaces¹ (Continued)

UNIT MODEL	FURNACE		COIL MODEL ²	COOLING				
	MODEL	WIDTH		RATED CFM	NET MBH		SEER	EER
					TOTAL	SENS.		
TW4B4821S	TM9E100C16MP11	21.0	CF/CM/CU48D	1350	48.0	33.6	15.00	12.50
TW4B4821S	TM9E100C16MP11	21.0	CF/CM/CU60C	1325	48.0	33.8	15.25	12.50
TW4B4821S	TM9E100C16MP11	21.0	CF/CM/CU60D	1325	48.0	33.8	15.25	12.50
TW4B4821S	TM9E100C16MP11	21.0	CF/CM64D	1350	48.0	33.4	15.50	12.75
TW4B4821S	TM9E100C16MP12	21.0	CF/CM/CU60D	1600	48.0	37.0	14.25	12.00
TW4B4821S	TM9E100C20MP11	21.0	CF/CM/CU48C	1400	48.0	34.8	15.25	12.50
TW4B4821S	TM9E100C20MP11	21.0	CF/CM/CU48D	1425	48.0	34.4	15.50	12.75
TW4B4821S	TM9E100C20MP11	21.0	CF/CM/CU60C	1400	48.0	34.4	15.50	12.75
TW4B4821S	TM9E100C20MP11	21.0	CF/CM/CU60D	1450	48.0	35.2	15.50	12.75
TW4B4821S	TM9E100C20MP11	21.0	CF/CM64D	1400	48.0	34.6	15.50	12.75
TW4B4821S	TM9E100C20MP12	21.0	CF/CM/CU48C	1400	48.0	35.0	15.25	12.50
TW4B4821S	TM9E100C20MP12	21.0	CF/CM/CU48D	1425	48.0	35.2	15.25	12.50
TW4B4821S	TM9E100C20MP12	21.0	CF/CM/CU60C	1400	48.0	35.0	15.25	12.50
TW4B4821S	TM9E100C20MP12	21.0	CF/CM/CU60D	1425	48.0	35.4	15.25	12.50
TW4B4821S	TM9E100C20MP12	21.0	CF/CM64D	1400	48.0	35.2	15.50	12.75
TW4B4821S	TM9E120D20MP11	24.5	CF/CM/CU48D	1425	48.0	34.4	15.50	12.75
TW4B4821S	TM9E120D20MP11	24.5	CF/CM/CU60D	1425	48.0	34.8	15.75	12.75
TW4B4821S	TM9E120D20MP11	24.5	CF/CM64D	1400	48.0	34.6	15.75	12.75
TW4B4821S	TM9E120D20MP12	24.5	CF/CM/CU48D	1450	48.0	35.6	15.25	12.50
TW4B4821S	TM9E120D20MP12	24.5	CF/CM/CU60D	1450	48.0	35.6	15.25	12.50
TW4B4821S	TM9E120D20MP12	24.5	CF/CM64D	1450	48.0	35.6	15.50	12.75
TW4B4821S	TM9V080C16MP11C	21.0	CF/CM/CU48C	1300	47.0	33.2	15.25	12.50
TW4B4821S	TM9V080C16MP11C	21.0	CF/CM/CU48D	1300	47.0	33.0	15.25	12.75
TW4B4821S	TM9V080C16MP11C	21.0	CF/CM/CU60C	1300	47.0	33.2	15.00	12.50
TW4B4821S	TM9V080C16MP11C	21.0	CF/CM/CU60D	1300	47.0	33.2	15.00	12.50
TW4B4821S	TM9V080C16MP11C	21.0	CF/CM64D	1300	47.0	33.4	15.50	12.75
TW4B4821S	TM9V080C16MP12C	21.0	CF/CM/CU48C	1300	47.0	33.2	15.25	12.50
TW4B4821S	TM9V080C16MP12C	21.0	CF/CM/CU48D	1300	47.0	33.0	15.25	12.75
TW4B4821S	TM9V080C16MP12C	21.0	CF/CM/CU60C	1300	47.0	33.2	15.00	12.50
TW4B4821S	TM9V080C16MP12C	21.0	CF/CM/CU60D	1300	47.0	33.2	15.00	12.50
TW4B4821S	TM9V080C16MP12C	21.0	CF/CM64D	1300	47.0	33.4	15.50	12.75
TW4B4821S	TM9V100C16MP11C	21.0	CF/CM/CU48C	1425	48.0	34.4	15.25	12.50
TW4B4821S	TM9V100C16MP11C	21.0	CF/CM/CU48D	1425	48.0	34.4	15.75	13.00
TW4B4821S	TM9V100C16MP11C	21.0	CF/CM/CU60C	1325	48.0	33.8	15.25	12.50
TW4B4821S	TM9V100C16MP11C	21.0	CF/CM/CU60D	1425	48.0	34.6	15.25	12.50
TW4B4821S	TM9V100C16MP11C	21.0	CF/CM64D	1300	48.0	33.6	15.75	12.75
TW4B4821S	TM9V100C16MP12C	21.0	CF/CM/CU48C	1325	47.0	34.0	15.00	12.50
TW4B4821S	TM9V100C16MP12C	21.0	CF/CM/CU48D	1325	47.0	34.0	15.25	12.50
TW4B4821S	TM9V100C16MP12C	21.0	CF/CM/CU60C	1325	46.5	33.6	15.00	12.50
TW4B4821S	TM9V100C16MP12C	21.0	CF/CM/CU60D	1425	47.0	34.8	15.00	12.50
TW4B4821S	TM9V100C16MP12C	21.0	CF/CM64D	1425	46.5	34.2	15.50	12.75
TW4B4821S	TM9V100C20MP11C	21.0	CF/CM/CU48C	1450	48.0	34.6	14.75	12.25
TW4B4821S	TM9V100C20MP11C	21.0	CF/CM/CU48D	1300	48.0	33.4	15.25	12.50
TW4B4821S	TM9V100C20MP11C	21.0	CF/CM/CU60C	1500	48.0	35.4	15.00	12.50
TW4B4821S	TM9V100C20MP11C	21.0	CF/CM/CU60D	1325	48.0	33.6	15.50	12.75
TW4B4821S	TM9V100C20MP11C	21.0	CF/CM64D	1300	48.0	33.6	15.75	12.75
TW4B4821S	TM9V100C20MP12C	21.0	CF/CM/CU48C	1350	47.5	34.2	14.75	12.25
TW4B4821S	TM9V100C20MP12C	21.0	CF/CM/CU48D	1350	47.5	34.0	15.25	12.50
TW4B4821S	TM9V100C20MP12C	21.0	CF/CM/CU60C	1350	47.5	34.4	14.75	12.25
TW4B4821S	TM9V100C20MP12C	21.0	CF/CM/CU60D	1350	46.5	33.6	15.25	12.50
TW4B4821S	TM9V100C20MP12C	21.0	CF/CM64D	1475	46.5	34.8	15.25	12.75
TW4B4821S	TM9V120D20MP11C	24.5	CF/CM/CU48D	1300	48.0	33.4	15.50	12.75
TW4B4821S	TM9V120D20MP11C	24.5	CF/CM/CU60D	1300	48.0	33.6	15.75	12.75

COOLING CAPACITY - With High Efficiency Motor Furnaces¹ (Continued)

UNIT MODEL	FURNACE		COIL MODEL ²	COOLING				
	MODEL	WIDTH		RATED CFM	NET MBH		SEER	EER
					TOTAL	SENS.		
TW4B4821S	TM9V120D20MP11C	24.5	CF/CM64D	1525	48.0	35.6	15.25	12.50
TW4B4821S	TM9V120D20MP12C	24.5	CF/CM/CU48D	1425	46.5	34.2	15.25	12.50
TW4B4821S	TM9V120D20MP12C	24.5	CF/CM/CU60D	1575	48.0	36.6	15.50	12.75
TW4B4821S	TM9V120D20MP12C	24.5	CF/CM64D	1575	48.0	36.6	15.25	12.50
TW4B4821S	TM9Y080C16MP11	21.0	CF/CM/CU48C	1325	48.0	33.6	15.00	12.50
TW4B4821S	TM9Y080C16MP11	21.0	CF/CM/CU48D	1350	48.0	33.6	15.00	12.50
TW4B4821S	TM9Y080C16MP11	21.0	CF/CM/CU60C	1325	48.0	33.8	15.25	12.50
TW4B4821S	TM9Y080C16MP11	21.0	CF/CM/CU60D	1325	48.0	33.8	15.25	12.50
TW4B4821S	TM9Y080C16MP11	21.0	CF/CM64D	1350	48.0	33.4	15.50	12.75
TW4B4821S	TM9Y100C16MP11	21.0	CF/CM/CU48C	1325	48.0	33.6	15.00	12.50
TW4B4821S	TM9Y100C16MP11	21.0	CF/CM/CU48D	1350	48.0	33.6	15.00	12.50
TW4B4821S	TM9Y100C16MP11	21.0	CF/CM/CU60C	1325	48.0	33.8	15.25	12.50
TW4B4821S	TM9Y100C16MP11	21.0	CF/CM/CU60D	1325	48.0	33.8	15.25	12.50
TW4B4821S	TM9Y100C16MP11	21.0	CF/CM64D	1350	48.0	33.4	15.50	12.75
TW4B4821S	TM9Y100C20MP11	21.0	CF/CM/CU48C	1400	48.0	34.8	15.25	12.50
TW4B4821S	TM9Y100C20MP11	21.0	CF/CM/CU48D	1425	48.0	34.4	15.50	12.75
TW4B4821S	TM9Y100C20MP11	21.0	CF/CM/CU60C	1400	48.0	34.4	15.50	12.75
TW4B4821S	TM9Y100C20MP11	21.0	CF/CM/CU60D	1450	48.0	35.2	15.50	12.75
TW4B4821S	TM9Y100C20MP11	21.0	CF/CM64D	1400	48.0	34.6	15.50	12.75
TW4B4821S	TM9Y120D20MP11	24.5	CF/CM/CU48D	1425	48.0	34.4	15.50	12.75
TW4B4821S	TM9Y120D20MP11	24.5	CF/CM/CU60D	1425	48.0	34.8	15.75	12.75
TW4B4821S	TM9Y120D20MP11	24.5	CF/CM64D	1400	48.0	34.6	15.75	12.75
TW4B4821S	TMLV080C16MP12C	21.0	CF/CM/CU48C	1425	47.0	34.4	15.00	12.50
TW4B4821S	TMLV080C16MP12C	21.0	CF/CM/CU48D	1425	48.0	35.2	15.00	12.50
TW4B4821S	TMLV080C16MP12C	21.0	CF/CM/CU60C	1425	47.0	34.8	15.00	12.50
TW4B4821S	TMLV080C16MP12C	21.0	CF/CM/CU60D	1425	47.0	34.8	15.25	12.75
TW4B4821S	TMLV080C16MP12C	21.0	CF/CM64D	1425	48.0	35.4	15.25	12.75
TW4B4821S	TMLV100C16MP12C	21.0	CF/CM/CU48C	1425	47.0	34.4	15.00	12.50
TW4B4821S	TMLV100C16MP12C	21.0	CF/CM/CU48D	1425	48.0	35.2	15.00	12.50
TW4B4821S	TMLV100C16MP12C	21.0	CF/CM/CU60C	1425	47.0	34.8	15.00	12.50
TW4B4821S	TMLV100C16MP12C	21.0	CF/CM/CU60D	1425	47.0	34.8	15.25	12.75
TW4B4821S	TMLV100C16MP12C	21.0	CF/CM64D	1425	48.0	35.4	15.25	12.75
TW4B4821S	TMLV100C20MP12C	21.0	CF/CM/CU48C	1425	47.0	34.6	15.00	12.50
TW4B4821S	TMLV100C20MP12C	21.0	CF/CM/CU48D	1375	48.0	34.6	15.50	12.75
TW4B4821S	TMLV100C20MP12C	21.0	CF/CM/CU60C	1375	47.5	34.6	15.25	12.75
TW4B4821S	TMLV100C20MP12C	21.0	CF/CM/CU60D	1475	48.0	35.8	15.00	12.50
TW4B4821S	TMLV100C20MP12C	21.0	CF/CM64D	1425	47.5	35.0	15.25	12.50
TW4B4821S	TMLV120C20MP12C	21.0	CF/CM/CU48C	1425	47.0	34.6	15.00	12.50
TW4B4821S	TMLV120C20MP12C	21.0	CF/CM/CU48D	1375	48.0	34.6	15.50	12.75
TW4B4821S	TMLV120C20MP12C	21.0	CF/CM/CU60C	1375	47.5	34.6	15.25	12.75
TW4B4821S	TMLV120C20MP12C	21.0	CF/CM/CU60D	1475	48.0	35.8	15.00	12.50
TW4B4821S	TMLV120C20MP12C	21.0	CF/CM64D	1425	47.5	35.0	15.25	12.50
TW4B4821S	TMLX080C16MP11	21.0	CF/CM/CU48C	1400	48.0	34.8	15.25	12.50
TW4B4821S	TMLX080C16MP11	21.0	CF/CM/CU48D	1425	48.0	34.2	15.25	12.50
TW4B4821S	TMLX080C16MP11	21.0	CF/CM/CU60C	1400	48.0	34.4	15.25	12.50
TW4B4821S	TMLX080C16MP11	21.0	CF/CM/CU60D	1425	48.0	34.6	15.50	12.75
TW4B4821S	TMLX080C16MP11	21.0	CF/CM64D	1400	48.0	34.6	15.50	12.75
TW4B4821S	TMLX100C16MP11	21.0	CF/CM/CU48C	1400	48.0	34.8	15.25	12.50
TW4B4821S	TMLX100C16MP11	21.0	CF/CM/CU48D	1425	48.0	34.2	15.25	12.50
TW4B4821S	TMLX100C16MP11	21.0	CF/CM/CU60C	1400	48.0	34.4	15.25	12.50
TW4B4821S	TMLX100C16MP11	21.0	CF/CM/CU60D	1425	48.0	34.6	15.50	12.75
TW4B4821S	TMLX100C16MP11	21.0	CF/CM64D	1400	48.0	34.6	15.50	12.75
TW4B4821S	TMLX100C20MP11	21.0	CF/CM/CU48C	1425	48.0	34.4	15.50	12.75

COOLING CAPACITY - With High Efficiency Motor Furnaces¹ (Continued)

UNIT MODEL	FURNACE		COIL MODEL ²	COOLING				
	MODEL	WIDTH		RATED CFM	NET MBH		SEER	EER
					TOTAL	SENS.		
TW4B4821S	TMLX100C20MP11	21.0	CF/CM/CU48D	1300	48.0	33.6	15.75	13.00
TW4B4821S	TMLX100C20MP11	21.0	CF/CM/CU60C	1450	48.0	35.2	15.50	12.75
TW4B4821S	TMLX100C20MP11	21.0	CF/CM/CU60D	1475	48.0	35.2	15.75	13.00
TW4B4821S	TMLX100C20MP11	21.0	CF/CM64D	1450	48.0	34.8	15.75	13.00
TW4B4821S	TMLX120C20MP11	21.0	CF/CM/CU48C	1425	48.0	34.4	15.50	12.75
TW4B4821S	TMLX120C20MP11	21.0	CF/CM/CU48D	1300	48.0	33.6	15.75	13.00
TW4B4821S	TMLX120C20MP11	21.0	CF/CM/CU60C	1450	48.0	35.2	15.50	12.75
TW4B4821S	TMLX120C20MP11	21.0	CF/CM/CU60D	1475	48.0	35.2	15.75	13.00
TW4B4821S	TMLX120C20MP11	21.0	CF/CM64D	1450	48.0	34.8	15.75	13.00
TW4B4821S	TP9C080C16MP12C	21.0	CF/CM/CU48C	1425	48.0	34.4	15.25	12.50
TW4B4821S	TP9C080C16MP12C	21.0	CF/CM/CU48D	1425	48.0	34.4	15.75	13.00
TW4B4821S	TP9C080C16MP12C	21.0	CF/CM/CU60C	1325	48.0	33.8	15.25	12.50
TW4B4821S	TP9C080C16MP12C	21.0	CF/CM/CU60D	1425	48.0	34.6	15.25	12.50
TW4B4821S	TP9C080C16MP12C	21.0	CF/CM64D	1300	48.0	33.6	15.75	12.75
TW4B4821S	TP9C080C16MP13C	21.0	CF/CM/CU48C	1300	47.0	33.2	15.25	12.50
TW4B4821S	TP9C080C16MP13C	21.0	CF/CM/CU48D	1300	47.0	33.0	15.25	12.75
TW4B4821S	TP9C080C16MP13C	21.0	CF/CM/CU60C	1300	47.0	33.2	15.00	12.50
TW4B4821S	TP9C080C16MP13C	21.0	CF/CM/CU60D	1300	47.0	33.2	15.00	12.50
TW4B4821S	TP9C080C16MP13C	21.0	CF/CM64D	1300	47.0	33.4	15.50	12.75
TW4B4821S	TP9C100C16MP12C	21.0	CF/CM/CU48C	1425	48.0	34.4	15.25	12.50
TW4B4821S	TP9C100C16MP12C	21.0	CF/CM/CU48D	1425	48.0	34.4	15.75	13.00
TW4B4821S	TP9C100C16MP12C	21.0	CF/CM/CU60C	1325	48.0	33.8	15.25	12.50
TW4B4821S	TP9C100C16MP12C	21.0	CF/CM/CU60D	1425	48.0	34.6	15.25	12.50
TW4B4821S	TP9C100C16MP12C	21.0	CF/CM64D	1300	48.0	33.6	15.75	12.75
TW4B4821S	TP9C100C16MP13C	21.0	CF/CM/CU48C	1325	47.0	34.0	15.00	12.50
TW4B4821S	TP9C100C16MP13C	21.0	CF/CM/CU48D	1325	47.0	34.0	15.25	12.50
TW4B4821S	TP9C100C16MP13C	21.0	CF/CM/CU60C	1325	46.5	33.6	15.00	12.50
TW4B4821S	TP9C100C16MP13C	21.0	CF/CM/CU60D	1425	47.0	34.8	15.00	12.50
TW4B4821S	TP9C100C16MP13C	21.0	CF/CM64D	1425	46.5	34.2	15.50	12.75
TW4B4821S	TP9C100C20MP12C	21.0	CF/CM/CU48C	1450	48.0	34.6	14.75	12.25
TW4B4821S	TP9C100C20MP12C	21.0	CF/CM/CU48D	1300	48.0	33.4	15.25	12.50
TW4B4821S	TP9C100C20MP12C	21.0	CF/CM/CU60C	1500	48.0	35.4	15.00	12.50
TW4B4821S	TP9C100C20MP12C	21.0	CF/CM/CU60D	1325	48.0	33.6	15.50	12.75
TW4B4821S	TP9C100C20MP12C	21.0	CF/CM64D	1300	48.0	33.6	15.75	12.75
TW4B4821S	TP9C100C20MP13C	21.0	CF/CM/CU48C	1350	47.5	34.2	14.75	12.25
TW4B4821S	TP9C100C20MP13C	21.0	CF/CM/CU48D	1350	47.5	34.0	15.25	12.50
TW4B4821S	TP9C100C20MP13C	21.0	CF/CM/CU60C	1350	47.5	34.4	14.75	12.25
TW4B4821S	TP9C100C20MP13C	21.0	CF/CM/CU60D	1350	46.5	33.6	15.25	12.50
TW4B4821S	TP9C100C20MP13C	21.0	CF/CM64D	1475	46.5	34.8	15.25	12.75
TW4B4821S	TP9C120D20MP13C	24.5	CF/CM/CU48D	1425	46.5	34.2	15.25	12.50
TW4B4821S	TP9C120D20MP13C	24.5	CF/CM/CU60D	1575	48.0	36.6	15.50	12.75
TW4B4821S	TP9C120D20MP13C	24.5	CF/CM64D	1575	48.0	36.6	15.25	12.50
TW4B4821S	TPLC080C16MP12C	21.0	CF/CM/CU48C	1325	48.0	33.4	15.00	12.50
TW4B4821S	TPLC080C16MP12C	21.0	CF/CM/CU48D	1300	48.0	33.4	15.25	12.50
TW4B4821S	TPLC080C16MP12C	21.0	CF/CM/CU60C	1325	48.0	33.6	15.50	12.75
TW4B4821S	TPLC080C16MP12C	21.0	CF/CM/CU60D	1325	48.0	33.6	15.50	12.75
TW4B4821S	TPLC080C16MP12C	21.0	CF/CM64D	1400	48.0	34.4	15.50	12.75
TW4B4821S	TPLC080C16MP13C	21.0	CF/CM/CU48C	1425	47.0	34.4	15.00	12.50
TW4B4821S	TPLC080C16MP13C	21.0	CF/CM/CU48D	1425	48.0	35.2	15.00	12.50
TW4B4821S	TPLC080C16MP13C	21.0	CF/CM/CU60C	1425	47.0	34.8	15.00	12.50
TW4B4821S	TPLC080C16MP13C	21.0	CF/CM/CU60D	1425	47.0	34.8	15.25	12.75
TW4B4821S	TPLC080C16MP13C	21.0	CF/CM64D	1425	48.0	35.4	15.25	12.75
TW4B4821S	TPLC100C16MP12C	21.0	CF/CM/CU48C	1325	48.0	33.4	15.00	12.50

COOLING CAPACITY - With High Efficiency Motor Furnaces¹ (Continued)

UNIT MODEL	FURNACE		COIL MODEL ²	COOLING				
	MODEL	WIDTH		RATED CFM	NET MBH		SEER	EER
					TOTAL	SENS.		
TW4B4821S	TPLC100C16MP12C	21.0	CF/CM/CU48D	1300	48.0	33.4	15.25	12.50
TW4B4821S	TPLC100C16MP12C	21.0	CF/CM/CU60C	1325	48.0	33.6	15.50	12.75
TW4B4821S	TPLC100C16MP12C	21.0	CF/CM/CU60D	1325	48.0	33.6	15.50	12.75
TW4B4821S	TPLC100C16MP12C	21.0	CF/CM64D	1400	48.0	34.4	15.50	12.75
TW4B4821S	TPLC100C16MP13C	21.0	CF/CM/CU48C	1425	47.0	34.4	15.00	12.50
TW4B4821S	TPLC100C16MP13C	21.0	CF/CM/CU48D	1425	48.0	35.2	15.00	12.50
TW4B4821S	TPLC100C16MP13C	21.0	CF/CM/CU60C	1425	47.0	34.8	15.00	12.50
TW4B4821S	TPLC100C16MP13C	21.0	CF/CM/CU60D	1425	47.0	34.8	15.25	12.75
TW4B4821S	TPLC100C16MP13C	21.0	CF/CM64D	1425	48.0	35.4	15.25	12.75
TW4B4821S	TPLC100C20MP13C	21.0	CF/CM/CU48C	1425	47.0	34.6	15.00	12.50
TW4B4821S	TPLC100C20MP13C	21.0	CF/CM/CU48D	1375	48.0	34.6	15.50	12.75
TW4B4821S	TPLC100C20MP13C	21.0	CF/CM/CU60C	1375	47.5	34.6	15.25	12.75
TW4B4821S	TPLC100C20MP13C	21.0	CF/CM/CU60D	1475	48.0	35.8	15.00	12.50
TW4B4821S	TPLC100C20MP13C	21.0	CF/CM64D	1425	47.5	35.0	15.25	12.50
TW4B4821S	TPLC120C20MP13C	21.0	CF/CM/CU48C	1425	47.0	34.6	15.00	12.50
TW4B4821S	TPLC120C20MP13C	21.0	CF/CM/CU48D	1375	48.0	34.6	15.50	12.75
TW4B4821S	TPLC120C20MP13C	21.0	CF/CM/CU60C	1375	47.5	34.6	15.25	12.75
TW4B4821S	TPLC120C20MP13C	21.0	CF/CM/CU60D	1475	48.0	35.8	15.00	12.50
TW4B4821S	TPLC120C20MP13C	21.0	CF/CM64D	1425	47.5	35.0	15.25	12.50
TW4B4821S	CP9C080C16MP12C	21.0	CF/CM/CU48C	1425	48.0	34.4	15.25	12.50
TW4B4821S	CP9C080C16MP12C	21.0	CF/CM/CU48D	1425	48.0	34.4	15.75	13.00
TW4B4821S	CP9C080C16MP12C	21.0	CF/CM/CU60C	1325	48.0	33.8	15.25	12.50
TW4B4821S	CP9C080C16MP12C	21.0	CF/CM/CU60D	1425	48.0	34.6	15.25	12.50
TW4B4821S	CP9C080C16MP12C	21.0	CF/CM64D	1300	48.0	33.6	15.75	12.75
TW4B4821S	CP9C080C16MP13C	21.0	CF/CM/CU48C	1300	47.0	33.2	15.25	12.50
TW4B4821S	CP9C080C16MP13C	21.0	CF/CM/CU48D	1300	47.0	33.0	15.25	12.75
TW4B4821S	CP9C080C16MP13C	21.0	CF/CM/CU60C	1300	47.0	33.2	15.00	12.50
TW4B4821S	CP9C080C16MP13C	21.0	CF/CM/CU60D	1300	47.0	33.2	15.00	12.50
TW4B4821S	CP9C080C16MP13C	21.0	CF/CM64D	1300	47.0	33.4	15.50	12.75
TW4B4821S	CP9C100C16MP12C	21.0	CF/CM/CU48C	1425	48.0	34.4	15.25	12.50
TW4B4821S	CP9C100C16MP12C	21.0	CF/CM/CU48D	1425	48.0	34.4	15.75	13.00
TW4B4821S	CP9C100C16MP12C	21.0	CF/CM/CU60C	1325	48.0	33.8	15.25	12.50
TW4B4821S	CP9C100C16MP12C	21.0	CF/CM/CU60D	1425	48.0	34.6	15.25	12.50
TW4B4821S	CP9C100C16MP12C	21.0	CF/CM64D	1300	48.0	33.6	15.75	12.75
TW4B4821S	CP9C100C16MP13C	21.0	CF/CM/CU48C	1325	47.0	34.0	15.00	12.50
TW4B4821S	CP9C100C16MP13C	21.0	CF/CM/CU48D	1325	47.0	34.0	15.25	12.50
TW4B4821S	CP9C100C16MP13C	21.0	CF/CM/CU60C	1325	46.5	33.6	15.00	12.50
TW4B4821S	CP9C100C16MP13C	21.0	CF/CM/CU60D	1425	47.0	34.8	15.00	12.50
TW4B4821S	CP9C100C16MP13C	21.0	CF/CM64D	1425	46.5	34.2	15.50	12.75
TW4B4821S	CP9C100C20MP12C	21.0	CF/CM/CU48C	1450	48.0	34.6	14.75	12.25
TW4B4821S	CP9C100C20MP12C	21.0	CF/CM/CU48D	1300	48.0	33.4	15.25	12.50
TW4B4821S	CP9C100C20MP12C	21.0	CF/CM/CU60C	1500	48.0	35.4	15.00	12.50
TW4B4821S	CP9C100C20MP12C	21.0	CF/CM/CU60D	1325	48.0	33.6	15.50	12.75
TW4B4821S	CP9C100C20MP12C	21.0	CF/CM64D	1300	48.0	33.6	15.75	12.75
TW4B4821S	CP9C100C20MP13C	21.0	CF/CM/CU48C	1350	47.5	34.2	14.75	12.25
TW4B4821S	CP9C100C20MP13C	21.0	CF/CM/CU48D	1350	47.5	34.0	15.25	12.50
TW4B4821S	CP9C100C20MP13C	21.0	CF/CM/CU60C	1350	47.5	34.4	14.75	12.25
TW4B4821S	CP9C100C20MP13C	21.0	CF/CM/CU60D	1350	46.5	33.6	15.25	12.50
TW4B4821S	CP9C100C20MP13C	21.0	CF/CM64D	1475	46.5	34.8	15.25	12.75
TW4B4821S	CP9C120D20MP12C	24.5	CF/CM/CU48D	1300	48.0	33.4	15.50	12.75
TW4B4821S	CP9C120D20MP12C	24.5	CF/CM/CU60D	1300	48.0	33.6	15.75	12.75
TW4B4821S	CP9C120D20MP12C	24.5	CF/CM64D	1525	48.0	35.6	15.25	12.50
TW4B4821S	CP9C120D20MP13C	24.5	CF/CM/CU48D	1425	46.5	34.2	15.25	12.50

COOLING CAPACITY - With High Efficiency Motor Furnaces¹ (Continued)

UNIT MODEL	FURNACE		COIL MODEL ²	COOLING				
	MODEL	WIDTH		RATED CFM	NET MBH		SEER	EER
					TOTAL	SENS.		
TW4B4821S	CP9C120D20MP13C	24.5	CF/CM/CU60D	1575	48.0	36.6	15.50	12.75
TW4B4821S	CP9C120D20MP13C	24.5	CF/CM64D	1575	48.0	36.6	15.25	12.50
TW4B4821S	CPLC080C16MP12C	21.0	CF/CM/CU48C	1325	48.0	33.4	15.00	12.50
TW4B4821S	CPLC080C16MP12C	21.0	CF/CM/CU48D	1300	48.0	33.4	15.25	12.50
TW4B4821S	CPLC080C16MP12C	21.0	CF/CM/CU60C	1325	48.0	33.6	15.50	12.75
TW4B4821S	CPLC080C16MP12C	21.0	CF/CM/CU60D	1325	48.0	33.6	15.50	12.75
TW4B4821S	CPLC080C16MP12C	21.0	CF/CM64D	1400	48.0	34.4	15.50	12.75
TW4B4821S	CPLC080C16MP13C	21.0	CF/CM/CU48C	1425	47.0	34.4	15.00	12.50
TW4B4821S	CPLC080C16MP13C	21.0	CF/CM/CU48D	1425	48.0	35.2	15.00	12.50
TW4B4821S	CPLC080C16MP13C	21.0	CF/CM/CU60C	1425	47.0	34.8	15.00	12.50
TW4B4821S	CPLC080C16MP13C	21.0	CF/CM/CU60D	1425	47.0	34.8	15.25	12.75
TW4B4821S	CPLC080C16MP13C	21.0	CF/CM64D	1425	48.0	35.4	15.25	12.75
TW4B4821S	CPLC100C16MP12C	21.0	CF/CM/CU48C	1325	48.0	33.4	15.00	12.50
TW4B4821S	CPLC100C16MP12C	21.0	CF/CM/CU48D	1300	48.0	33.4	15.25	12.50
TW4B4821S	CPLC100C16MP12C	21.0	CF/CM/CU60C	1325	48.0	33.6	15.50	12.75
TW4B4821S	CPLC100C16MP12C	21.0	CF/CM/CU60D	1325	48.0	33.6	15.50	12.75
TW4B4821S	CPLC100C16MP12C	21.0	CF/CM64D	1400	48.0	34.4	15.50	12.75
TW4B4821S	CPLC100C16MP13C	21.0	CF/CM/CU48C	1425	47.0	34.4	15.00	12.50
TW4B4821S	CPLC100C16MP13C	21.0	CF/CM/CU48D	1425	48.0	35.2	15.00	12.50
TW4B4821S	CPLC100C16MP13C	21.0	CF/CM/CU60C	1425	47.0	34.8	15.00	12.50
TW4B4821S	CPLC100C16MP13C	21.0	CF/CM/CU60D	1425	47.0	34.8	15.25	12.75
TW4B4821S	CPLC100C16MP13C	21.0	CF/CM64D	1425	48.0	35.4	15.25	12.75
TW4B4821S	CPLC100C20MP12C	21.0	CF/CM/CU48C	1300	48.0	33.4	15.25	12.50
TW4B4821S	CPLC100C20MP12C	21.0	CF/CM/CU48D	1650	48.0	35.2	15.75	12.75
TW4B4821S	CPLC100C20MP12C	21.0	CF/CM/CU60C	1400	48.0	34.4	15.50	12.75
TW4B4821S	CPLC100C20MP12C	21.0	CF/CM/CU60D	1350	48.0	33.8	15.25	12.50
TW4B4821S	CPLC100C20MP12C	21.0	CF/CM64D	1425	48.0	34.8	15.50	12.75
TW4B4821S	CPLC100C20MP13C	21.0	CF/CM/CU48C	1425	47.0	34.6	15.00	12.50
TW4B4821S	CPLC100C20MP13C	21.0	CF/CM/CU48D	1375	48.0	34.6	15.50	12.75
TW4B4821S	CPLC100C20MP13C	21.0	CF/CM/CU60C	1375	47.5	34.6	15.25	12.75
TW4B4821S	CPLC100C20MP13C	21.0	CF/CM/CU60D	1475	48.0	35.8	15.00	12.50
TW4B4821S	CPLC100C20MP13C	21.0	CF/CM64D	1425	47.5	35.0	15.25	12.50
TW4B4821S	CPLC120C20MP12C	21.0	CF/CM/CU48C	1300	48.0	33.4	15.25	12.50
TW4B4821S	CPLC120C20MP12C	21.0	CF/CM/CU48D	1650	48.0	35.2	15.75	12.75
TW4B4821S	CPLC120C20MP12C	21.0	CF/CM/CU60C	1400	48.0	34.4	15.50	12.75
TW4B4821S	CPLC120C20MP12C	21.0	CF/CM/CU60D	1350	48.0	33.8	15.25	12.50
TW4B4821S	CPLC120C20MP12C	21.0	CF/CM64D	1425	48.0	34.8	15.50	12.75
TW4B4821S	CPLC120C20MP13C	21.0	CF/CM/CU48C	1425	47.0	34.6	15.00	12.50
TW4B4821S	CPLC120C20MP13C	21.0	CF/CM/CU48D	1375	48.0	34.6	15.50	12.75
TW4B4821S	CPLC120C20MP13C	21.0	CF/CM/CU60C	1375	47.5	34.6	15.25	12.75
TW4B4821S	CPLC120C20MP13C	21.0	CF/CM/CU60D	1475	48.0	35.8	15.00	12.50
TW4B4821S	CPLC120C20MP13C	21.0	CF/CM64D	1425	47.5	35.0	15.25	12.50
TW4B6021S	TL8E080C16UH11	21.0	CF/CM/CU60D	1575	55.5	40.5	14.00	11.75
TW4B6021S	TL8E080C16UH11	21.0	CF/CM64D	1550	56.0	40.5	14.25	12.00
TW4B6021S	TL8E100C20UH11	21.0	CF/CM/CU60C	1600	55.0	40.0	14.00	11.75
TW4B6021S	TL8E100C20UH11	21.0	CF/CM/CU60D	1625	56.0	41.5	14.25	12.00
TW4B6021S	TL8E100C20UH11	21.0	CF/CM64D	1600	57.0	41.5	14.50	12.25
TW4B6021S	TL9E100C20UH11	21.0	CF/CM/CU60C	1600	54.5	39.5	14.00	11.75
TW4B6021S	TL9E100C20UH11	21.0	CF/CM/CU60D	1625	56.0	41.5	14.25	12.00
TW4B6021S	TL9E100C20UH11	21.0	CF/CM64D	1600	57.0	41.5	14.25	12.00
TW4B6021S	TM8E080C16MP11	21.0	CF/CM/CU60D	1600	55.5	41.0	14.00	11.75
TW4B6021S	TM8E080C16MP11	21.0	CF/CM64D	1575	56.5	41.0	14.25	12.00
TW4B6021S	TM8E080C20MP11	21.0	CF/CM/CU60C	1550	55.0	39.5	14.00	11.75

COOLING CAPACITY - With High Efficiency Motor Furnaces¹ (Continued)

UNIT MODEL	FURNACE		COIL MODEL ²	COOLING				
	MODEL	WIDTH		RATED CFM	NET MBH		SEER	EER
					TOTAL	SENS.		
TW4B6021S	TM8E080C20MP11	21.0	CF/CM/CU60D	1575	55.5	40.5	14.50	12.00
TW4B6021S	TM8E080C20MP11	21.0	CF/CM64D	1575	56.5	41.0	14.50	12.25
TW4B6021S	TM8E100C16MP11	21.0	CF/CM/CU60D	1600	55.5	41.0	14.00	11.75
TW4B6021S	TM8E100C16MP11	21.0	CF/CM64D	1575	56.5	41.0	14.25	12.00
TW4B6021S	TM8E100C20MP11	21.0	CF/CM/CU60D	1550	55.5	40.0	14.50	12.00
TW4B6021S	TM8E100C20MP11	21.0	CF/CM64D	1525	56.5	40.5	14.50	12.25
TW4B6021S	TM8E120C16MP11	21.0	CF/CM/CU60D	1600	55.5	41.0	14.25	11.75
TW4B6021S	TM8E120C16MP11	21.0	CF/CM64D	1575	56.5	41.0	14.25	12.00
TW4B6021S	TM8E120C20MP11	21.0	CF/CM/CU60D	1525	55.5	40.0	14.50	12.00
TW4B6021S	TM8E120C20MP11	21.0	CF/CM64D	1525	56.5	40.5	14.50	12.25
TW4B6021S	TM8E130D20MP11	24.5	CF/CM/CU60D	1650	56.0	41.5	14.25	12.00
TW4B6021S	TM8E130D20MP11	24.5	CF/CM64D	1625	57.0	42.0	14.50	12.25
TW4B6021S	TM8V080C16MP11C	21.0	CF/CM/CU60D	1700	55.5	41.5	14.00	11.70
TW4B6021S	TM8V080C16MP12C	21.0	CF/CM/CU60D	1700	55.5	41.5	14.00	11.70
TW4B6021S	TM8V100C16MP11C	21.0	CF/CM/CU60D	1700	55.5	41.5	14.00	11.70
TW4B6021S	TM8V100C16MP12C	21.0	CF/CM/CU60D	1700	55.5	41.5	14.00	11.70
TW4B6021S	TM8V100C20MP11C	21.0	CF/CM/CU60C	1625	55.0	41.0	14.00	11.75
TW4B6021S	TM8V100C20MP11C	21.0	CF/CM/CU60D	1625	55.5	41.0	14.50	12.00
TW4B6021S	TM8V100C20MP12C	21.0	CF/CM/CU60C	1625	55.0	41.0	14.00	11.75
TW4B6021S	TM8V100C20MP12C	21.0	CF/CM/CU60D	1625	55.5	41.0	14.50	12.00
TW4B6021S	TM8V100C20MP12C	21.0	CF/CM64D	1550	55.5	40.0	14.25	12.20
TW4B6021S	TM8V120C20MP11C	21.0	CF/CM/CU60C	1625	55.0	41.0	14.00	11.75
TW4B6021S	TM8V120C20MP12C	21.0	CF/CM/CU60C	1625	55.0	41.0	14.00	11.75
TW4B6021S	TM8V120C20MP12C	21.0	CF/CM/CU60D	1625	55.5	41.0	14.50	12.00
TW4B6021S	TM8V120C20MP12C	21.0	CF/CM64D	1550	55.5	40.0	14.25	12.20
TW4B6021S	TM8X080C16MP11	21.0	CF/CM/CU60D	1550	54.0	39.0	14.00	11.70
TW4B6021S	TM8X080C16MP11	21.0	CF/CM64D	1525	54.5	39.0	14.00	11.70
TW4B6021S	TM8X100C16MP11	21.0	CF/CM/CU60D	1550	54.0	39.0	14.00	11.70
TW4B6021S	TM8X100C16MP11	21.0	CF/CM64D	1525	54.5	39.0	14.00	11.70
TW4B6021S	TM8X100C20MP11	21.0	CF/CM/CU60C	1550	54.5	39.5	14.25	12.00
TW4B6021S	TM8X100C20MP11	21.0	CF/CM/CU60D	1600	55.0	40.5	14.25	12.00
TW4B6021S	TM8X100C20MP11	21.0	CF/CM64D	1550	55.5	40.0	14.50	12.25
TW4B6021S	TM8X120C20MP11	21.0	CF/CM/CU60C	1550	54.5	39.5	14.25	12.00
TW4B6021S	TM8X120C20MP11	21.0	CF/CM/CU60D	1600	55.0	40.5	14.25	12.00
TW4B6021S	TM8X120C20MP11	21.0	CF/CM64D	1550	55.5	40.0	14.50	12.25
TW4B6021S	TM8Y080C16MP11	21.0	CF/CM/CU60D	1550	54.0	39.0	14.00	11.70
TW4B6021S	TM8Y080C16MP11	21.0	CF/CM64D	1525	54.5	39.0	14.00	11.70
TW4B6021S	TM8Y100C16MP11	21.0	CF/CM/CU60D	1550	54.0	39.0	14.00	11.70
TW4B6021S	TM8Y100C16MP11	21.0	CF/CM64D	1525	54.5	39.0	14.00	11.70
TW4B6021S	TM8Y100C20MP11	21.0	CF/CM/CU60C	1550	54.5	39.5	14.25	12.00
TW4B6021S	TM8Y100C20MP11	21.0	CF/CM/CU60D	1600	55.0	40.5	14.25	12.00
TW4B6021S	TM8Y100C20MP11	21.0	CF/CM64D	1550	55.5	40.0	14.50	12.25
TW4B6021S	TM8Y120C20MP11	21.0	CF/CM/CU60C	1550	54.5	39.5	14.25	12.00
TW4B6021S	TM8Y120C20MP11	21.0	CF/CM/CU60D	1600	55.0	40.5	14.25	12.00
TW4B6021S	TM8Y120C20MP11	21.0	CF/CM64D	1550	55.5	40.0	14.50	12.25
TW4B6021S	TM9E080C20MP12	21.0	CF/CM/CU60D	1525	55.5	40.0	14.50	12.00
TW4B6021S	TM9E080C20MP12	21.0	CF/CM64D	1750	57.5	43.5	14.25	12.00
TW4B6021S	TM9E100C20MP11	21.0	CF/CM/CU60C	1525	54.0	39.0	14.00	11.70
TW4B6021S	TM9E100C20MP11	21.0	CF/CM/CU60D	1550	54.5	39.5	14.00	11.75
TW4B6021S	TM9E100C20MP11	21.0	CF/CM64D	1550	55.0	40.0	14.00	11.75
TW4B6021S	TM9E100C20MP12	21.0	CF/CM/CU60D	1550	55.5	40.0	14.50	12.00
TW4B6021S	TM9E100C20MP12	21.0	CF/CM64D	1525	56.5	40.5	14.50	12.25
TW4B6021S	TM9E120D20MP11	24.5	CF/CM/CU60D	1600	55.0	40.5	14.25	12.00

COOLING CAPACITY - With High Efficiency Motor Furnaces¹ (Continued)

UNIT MODEL	FURNACE		COIL MODEL ²	COOLING				
	MODEL	WIDTH		RATED CFM	NET MBH		SEER	EER
					TOTAL	SENS.		
TW4B6021S	TM9E120D20MP11	24.5	CF/CM64D	1575	55.5	40.5	14.25	11.75
TW4B6021S	TM9E120D20MP12	24.5	CF/CM/CU60D	1625	56.0	41.5	14.25	12.00
TW4B6021S	TM9E120D20MP12	24.5	CF/CM64D	1600	57.0	41.5	14.25	12.00
TW4B6021S	TM9V100C16MP11C	21.0	CF/CM/CU60C	1600	54.5	40.0	14.00	11.75
TW4B6021S	TM9V100C16MP11C	21.0	CF/CM/CU60D	1600	55.0	40.5	14.00	11.75
TW4B6021S	TM9V100C16MP11C	21.0	CF/CM64D	1600	56.0	40.5	14.25	12.00
TW4B6021S	TM9V100C16MP12C	21.0	CF/CM/CU60C	1600	54.5	40.0	14.00	11.75
TW4B6021S	TM9V100C16MP12C	21.0	CF/CM/CU60D	1600	55.0	40.5	14.00	11.75
TW4B6021S	TM9V100C16MP12C	21.0	CF/CM64D	1600	56.0	40.5	14.25	12.00
TW4B6021S	TM9V100C20MP11C	21.0	CF/CM/CU60C	1600	55.0	40.5	14.00	11.70
TW4B6021S	TM9V100C20MP11C	21.0	CF/CM64D	1600	56.0	40.5	14.00	11.75
TW4B6021S	TM9V100C20MP12C	21.0	CF/CM/CU60C	1600	55.0	40.5	14.00	11.70
TW4B6021S	TM9V100C20MP12C	21.0	CF/CM64D	1600	56.0	40.5	14.00	11.75
TW4B6021S	TM9V120D20MP11C	24.5	CF/CM/CU60D	1575	55.0	40.5	14.25	11.75
TW4B6021S	TM9V120D20MP11C	24.5	CF/CM64D	1575	55.5	40.5	14.25	11.75
TW4B6021S	TM9V120D20MP12C	24.5	CF/CM/CU60D	1575	55.0	40.5	14.25	11.75
TW4B6021S	TM9V120D20MP12C	24.5	CF/CM64D	1575	55.5	40.5	14.25	11.75
TW4B6021S	TM9Y100C20MP11	21.0	CF/CM/CU60C	1525	54.0	39.0	14.00	11.70
TW4B6021S	TM9Y100C20MP11	21.0	CF/CM/CU60D	1550	54.5	39.5	14.00	11.75
TW4B6021S	TM9Y100C20MP11	21.0	CF/CM64D	1550	55.0	40.0	14.00	11.75
TW4B6021S	TM9Y120D20MP11	24.5	CF/CM/CU60D	1600	55.0	40.5	14.25	12.00
TW4B6021S	TM9Y120D20MP11	24.5	CF/CM64D	1575	55.5	40.5	14.25	11.75
TW4B6021S	TMLV080C16MP11C	21.0	CF/CM/CU60D	1700	55.5	41.5	14.00	11.70
TW4B6021S	TMLV080C16MP12C	21.0	CF/CM/CU60D	1700	55.5	41.5	14.00	11.70
TW4B6021S	TMLV100C16MP11C	21.0	CF/CM/CU60D	1700	55.5	41.5	14.00	11.70
TW4B6021S	TMLV100C16MP12C	21.0	CF/CM/CU60D	1700	55.5	41.5	14.00	11.70
TW4B6021S	TMLV100C20MP11C	21.0	CF/CM/CU60C	1625	55.0	41.0	14.00	11.75
TW4B6021S	TMLV100C20MP12C	21.0	CF/CM/CU60C	1625	55.0	41.0	14.00	11.75
TW4B6021S	TMLV100C20MP12C	21.0	CF/CM/CU60D	1625	55.5	41.0	14.50	12.00
TW4B6021S	TMLV100C20MP12C	21.0	CF/CM64D	1550	55.5	40.0	14.25	12.20
TW4B6021S	TMLV120C20MP11C	21.0	CF/CM/CU60C	1625	55.0	41.0	14.00	11.75
TW4B6021S	TMLV120C20MP12C	21.0	CF/CM/CU60C	1625	55.0	41.0	14.00	11.75
TW4B6021S	TMLV120C20MP12C	21.0	CF/CM/CU60D	1625	55.5	41.0	14.50	12.00
TW4B6021S	TMLV120C20MP12C	21.0	CF/CM64D	1550	55.5	40.0	14.25	12.20
TW4B6021S	TMLX080C16MP11	21.0	CF/CM/CU60D	1550	54.0	39.0	14.00	11.70
TW4B6021S	TMLX080C16MP11	21.0	CF/CM64D	1525	54.5	39.0	14.00	11.70
TW4B6021S	TMLX100C16MP11	21.0	CF/CM/CU60D	1550	54.0	39.0	14.00	11.70
TW4B6021S	TMLX100C16MP11	21.0	CF/CM64D	1525	54.5	39.0	14.00	11.70
TW4B6021S	TMLX100C20MP11	21.0	CF/CM/CU60C	1550	54.5	39.5	14.25	12.00
TW4B6021S	TMLX100C20MP11	21.0	CF/CM/CU60D	1600	55.0	40.5	14.25	12.00
TW4B6021S	TMLX100C20MP11	21.0	CF/CM64D	1550	55.5	40.0	14.50	12.25
TW4B6021S	TMLX120C20MP11	21.0	CF/CM/CU60C	1550	54.5	39.5	14.25	12.00
TW4B6021S	TMLX120C20MP11	21.0	CF/CM/CU60D	1600	55.0	40.5	14.25	12.00
TW4B6021S	TMLX120C20MP11	21.0	CF/CM64D	1550	55.5	40.0	14.50	12.25
TW4B6021S	TP9C100C16MP12C	21.0	CF/CM/CU60C	1600	54.5	40.0	14.00	11.75
TW4B6021S	TP9C100C16MP12C	21.0	CF/CM/CU60D	1600	55.0	40.5	14.00	11.75
TW4B6021S	TP9C100C16MP12C	21.0	CF/CM64D	1600	56.0	40.5	14.25	12.00
TW4B6021S	TP9C100C16MP13C	21.0	CF/CM/CU60C	1600	54.5	40.0	14.00	11.75
TW4B6021S	TP9C100C16MP13C	21.0	CF/CM/CU60D	1600	55.0	40.5	14.00	11.75
TW4B6021S	TP9C100C16MP13C	21.0	CF/CM64D	1600	56.0	40.5	14.25	12.00
TW4B6021S	TP9C100C20MP12C	21.0	CF/CM/CU60C	1600	55.0	40.5	14.00	11.70
TW4B6021S	TP9C100C20MP12C	21.0	CF/CM64D	1600	56.0	40.5	14.00	11.75
TW4B6021S	TP9C100C20MP13C	21.0	CF/CM/CU60C	1600	55.0	40.5	14.00	11.70

COOLING CAPACITY - With High Efficiency Motor Furnaces¹ (Continued)

UNIT MODEL	FURNACE		COIL MODEL ²	COOLING				
	MODEL	WIDTH		RATED CFM	NET MBH		SEER	EER
					TOTAL	SENS.		
TW4B6021S	TP9C100C20MP13C	21.0	CF/CM64D	1600	56.0	40.5	14.00	11.75
TW4B6021S	TP9C120D20MP13C	24.5	CF/CM/CU60D	1575	55.0	40.5	14.25	11.75
TW4B6021S	TP9C120D20MP13C	24.5	CF/CM64D	1575	55.5	40.5	14.25	11.75
TW4B6021S	TPLC080C16MP12C	21.0	CF/CM/CU60D	1700	55.5	41.5	14.00	11.70
TW4B6021S	TPLC080C16MP13C	21.0	CF/CM/CU60D	1700	55.5	41.5	14.00	11.70
TW4B6021S	TPLC100C16MP12C	21.0	CF/CM/CU60D	1700	55.5	41.5	14.00	11.70
TW4B6021S	TPLC100C16MP13C	21.0	CF/CM/CU60D	1700	55.5	41.5	14.00	11.70
TW4B6021S	TPLC100C20MP12C	21.0	CF/CM/CU60C	1625	55.0	41.0	14.00	11.75
TW4B6021S	TPLC100C20MP13C	21.0	CF/CM/CU60C	1625	55.0	41.0	14.00	11.75
TW4B6021S	TPLC100C20MP13C	21.0	CF/CM/CU60D	1625	55.5	41.0	14.50	12.00
TW4B6021S	TPLC100C20MP13C	21.0	CF/CM64D	1550	55.5	40.0	14.25	12.20
TW4B6021S	TPLC120C20MP12C	21.0	CF/CM/CU60C	1625	55.0	41.0	14.00	11.75
TW4B6021S	TPLC120C20MP13C	21.0	CF/CM/CU60C	1625	55.0	41.0	14.00	11.75
TW4B6021S	TPLC120C20MP13C	21.0	CF/CM/CU60D	1625	55.5	41.0	14.50	12.00
TW4B6021S	TPLC120C20MP13C	21.0	CF/CM64D	1550	55.5	40.0	14.25	12.20
TW4B6021S	CP9C100C16MP12C	21.0	CF/CM/CU60C	1600	54.5	40.0	14.00	11.75
TW4B6021S	CP9C100C16MP12C	21.0	CF/CM/CU60D	1600	55.0	40.5	14.00	11.75
TW4B6021S	CP9C100C16MP12C	21.0	CF/CM64D	1600	56.0	40.5	14.25	12.00
TW4B6021S	CP9C100C16MP13C	21.0	CF/CM/CU60C	1600	54.5	40.0	14.00	11.75
TW4B6021S	CP9C100C16MP13C	21.0	CF/CM/CU60D	1600	55.0	40.5	14.00	11.75
TW4B6021S	CP9C100C16MP13C	21.0	CF/CM64D	1600	56.0	40.5	14.25	12.00
TW4B6021S	CP9C100C20MP12C	21.0	CF/CM/CU60C	1600	55.0	40.5	14.00	11.70
TW4B6021S	CP9C100C20MP12C	21.0	CF/CM64D	1600	56.0	40.5	14.00	11.75
TW4B6021S	CP9C100C20MP13C	21.0	CF/CM/CU60C	1600	55.0	40.5	14.00	11.70
TW4B6021S	CP9C100C20MP13C	21.0	CF/CM64D	1600	56.0	40.5	14.00	11.75
TW4B6021S	CP9C120D20MP12C	24.5	CF/CM/CU60D	1575	55.0	40.5	14.25	11.75
TW4B6021S	CP9C120D20MP12C	24.5	CF/CM64D	1575	55.5	40.5	14.25	11.75
TW4B6021S	CP9C120D20MP13C	24.5	CF/CM/CU60D	1575	55.0	40.5	14.25	11.75
TW4B6021S	CP9C120D20MP13C	24.5	CF/CM64D	1575	55.5	40.5	14.25	11.75
TW4B6021S	CPLC080C16MP12C	21.0	CF/CM/CU60D	1700	55.5	41.5	14.00	11.70
TW4B6021S	CPLC080C16MP13C	21.0	CF/CM/CU60D	1700	55.5	41.5	14.00	11.70
TW4B6021S	CPLC100C16MP12C	21.0	CF/CM/CU60D	1700	55.5	41.5	14.00	11.70
TW4B6021S	CPLC100C16MP13C	21.0	CF/CM/CU60D	1700	55.5	41.5	14.00	11.70
TW4B6021S	CPLC100C20MP12C	21.0	CF/CM/CU60C	1625	55.0	41.0	14.00	11.75
TW4B6021S	CPLC100C20MP12C	21.0	CF/CM/CU60D	1625	55.5	41.0	14.50	12.00
TW4B6021S	CPLC100C20MP13C	21.0	CF/CM/CU60C	1625	55.0	41.0	14.00	11.75
TW4B6021S	CPLC100C20MP13C	21.0	CF/CM/CU60D	1625	55.5	41.0	14.50	12.00
TW4B6021S	CPLC100C20MP13C	21.0	CF/CM64D	1550	55.5	40.0	14.25	12.20
TW4B6021S	CPLC120C20MP12C	21.0	CF/CM/CU60C	1625	55.0	41.0	14.00	11.75
TW4B6021S	CPLC120C20MP12C	21.0	CF/CM/CU60D	1625	55.5	41.0	14.50	12.00
TW4B6021S	CPLC120C20MP13C	21.0	CF/CM/CU60C	1625	55.0	41.0	14.00	11.75
TW4B6021S	CPLC120C20MP13C	21.0	CF/CM/CU60D	1625	55.5	41.0	14.50	12.00
TW4B6021S	CPLC120C20MP13C	21.0	CF/CM64D	1550	55.5	40.0	14.25	12.20

For rated condition information, see the footnotes below the System Capacity - Single Piece and Modular Air Handlers table.

1. High Efficiency Motor Furnaces have B.O.D (Blower Off Delay) standard.
 2. CM coils available with a factory installed horizontal drain pan. See price pages for specific model number.
- PSC furnaces, such as the TG8S, TGLS, and TG9S, use Coil Only Ratings.

APPLICATIONS AND ACCESSORIES

Refer to Price Manual for specific model numbers.

Standard Application Limits*		
Maximum Lineset Equivalent Length	80 Ft	
Outdoor Ambient Temperature Limits		
Cooling Operation	Maximum DB	125°F
	Minimum DB	55°F

* For Low Ambient and/or Long Lineset Applications, please see the accessories listed below.

Non-Standard Lineset Applications - For installations with reduced diameter or long linesets, refer to the current version of the Piping Application Guide P/N 247077, available in the Application Bulletins section on www.simplygettingthejobdone.com.

OD Unit Anti Short Cycle Kit (10 Pack) S1-2TD08700124BK: A time delay that prevents rapid compressor restarting as a result of power interruption, limit switch operation, or thermostat resetting. Not required for HP models, or for AC models with factory electronic controls.

Standard Low Ambient Control Kit S1-2LA06700424: Allows the use of air conditioning at low outdoor ambient temperatures down to +20°F (-7°C). For use with all R-410A single stage AC & HP models.

Advanced Low Ambient Control Kit S1-2LA04701024: Contains the necessary components and controls to allow cooling operation down to -20°F (-29°C). For use with some R-410A single stage AC & HP models. This accessory can only be applied to models that contain a PSC outdoor fan motor.

Low Pressure Switch Kit S1-2PS06700524: Provides field installed low pressure (loss of charge) protection. Not required for HP models, or for AC models with factory electronic controls.

High Ambient Outdoor Fan Motor S1-FHM**HT:** Class F 70°C motor to allow cooling operation up to 160°F air entering the outdoor coil. For use with all R-410A single stage AC & HP models containing R-410A refrigerant only.

Outdoor Communicating Board Kit (S1-33102952310): Electronic control upgrade for standard air conditioning units to provide compatibility with the Residential Touch Screen Communicating Control.

Start Assist Kit S1-2SA067**:** Provides increased compressor starting torque for areas with low supply voltage. Required for units with recip compressors when applied with indoor TXV, and for all units when applied with long linesets or low ambient kits. May be factory installed on select AC & HP units (see Physical & Electrical Table). See Price Pages or Source1 SmartSearch for the correct kit for each application.

Compressor Crankcase Heater Kit (S1-025-**-***):** A wrap-around electrical resistance heater that warms the compressor sump, reducing the chance of liquid slugging on startup. Required on all long lineset and low ambient applications. See Price Pages or Source1 SmartSearch for the correct part for each application.

Support Feet S1-HPRKIT:** Kit of 5 support feet to raise unit above snow or landscaping. Available in heights of 3", 6" or 12".

Anchor Bracket Kit S1-1HK0401: Firmly anchors unit to pad or support structure. When properly installed, approved for ground-mounted or roof-mounted applications.

Indoor TXV Kit S1-1TVM*:** Thermal expansion valves precisely meter refrigerant for optimum performance over a wide range of conditions. See System Charge Table, Price Pages, or Source1 Smart Search for TXV part number for each AC & HP model.

Wall Mount Kit (S1-ACB):** Includes two brackets to allow outdoor unit to be securely mounted to a vertical wall. Mounting hardware is field sourced according to the specific application.

Winter Cover Kit S1-CCVRE*:** Custom fit winter cover protects AC condensing unit from debris during the off-season. Must be removed prior to unit operation. See Price Pages or Source1 SmartSearch for the correct cover for each application.

Cold Weather Charging Tent S1-CHGTENT01: Provides warm environment to accurately service AC & HP systems in ambient conditions 55°F (13°C) or colder.

Touch-up Paint S1-5130153**:** Color matched aerosol paint for touching up unit chassis and panels. See Price Pages or Source1 SmartSearch for the correct color for each application.

Compressor Sound Blanket S1-010-07xx-000: A field installed dense foam cover that provides 2dBA sound level reduction. See Price Pages or Source1 SmartSearch for the correct blanket for each application.

Thermostat: Compatible thermostat controls are available through accessory sourcing. For optimum performance, these outdoor units are fully compatible with our Coleman Hx™ Touchscreen Thermostats available through Source1. For more information, see the thermostat section of the Product Equipment Catalog.

SOUND POWER RATINGS

Cooling Model Number	Octave Band Sound Power Level (db re. 1-pW)									dBA	SQI
	63	125	250	500	1000	2000	4000	8000			
TW4B1821S	70.8	67.1	62.1	65.4	63.8	66.7	56.1	55.8	70.0	19.0	
TW4B2421S	68.8	71.9	66.4	70.0	68.3	63.5	59.2	56.1	72.0	19.0	
TW4B3021S	68.9	71.6	67.4	70.8	67.2	66.2	59.3	60.5	73.0	19.2	
TW4B3621S	71.6	76.2	68.5	69.5	67.1	62.6	57.7	57.0	72.0	19.1	
TW4B4221S	70.3	72.5	71.7	72.3	69.7	65.9	61.8	58.4	74.0	19.1	
TW4B4821S	68.6	76.8	71.4	71.4	70.9	63.8	60.9	58.7	75.0	19.0	
TW4B6021S	72.9	73.3	71.3	74.3	70.7	66.5	64.5	64.4	76.0	19.2	

Rated in accordance with ARI Standard 270.

MECHANICAL SPECIFICATIONS

MANUFACTURE AND CERTIFICATIONS

- Units shall be manufactured in an ISO 9001 certified facility.
- Units shall be certified by CSA to UL 1995 / CSA 22.2 and performance certified to ANSI/AHRI Standard 210/240.
- Units shall be sound tested according to ANSI/AHRI Standard 270.
- Certified matched system ratings will be available for download from the AHRI online directory at www.ahridirectory.org
- Unit packaging shall be marked, "Assembled in the USA"

UNIT APPLICATION

- Units shall be approved for cooling operation between 55°F and 125°F without modification.
- Units shall be approved for linesets up to 80 feet equivalent length without modification.
- Units shall be approved for installation within 6 inches of a flat vertical wall without modification, according to the instructions in the technical literature.
- Units shall be certified to the 5th Edition (2014) of the Florida Building Code for a combined allowable lateral and uplift wind force of 200 psf and 100 psf, respectively, for both ground-mounted and rooftop-mounted applications up to 200 feet above grade with approved mounting kit.
- Units shall be designed to 76dBA or less to minimize sound pollution.

UNIT ACCESS

- Units shall have a removable fan guard that can be removed independently of the top for interior access through the top of the unit without damaging the coil.
- Units shall have two removable stamped steel coil guards for exterior coil access.
- Units shall have a separate compartment for electrical controls that can be accessed without disturbing the unit airflow.
- Units shall have a blockoff panel that can be removed to provide interior unit access through the side of the unit.
- Units shall have a removable blockoff panel and a swing away removable electrical panel that provides sufficient interior unit access for removing the compressor through the side of the unit.

UNIT CONSTRUCTION

- Units shall be shipped completely wired, piped and assembled. Wiring pigtails shall be provided for field control wiring connections. Service valves shall be provided for field refrigerant line connections.

- Units shall be factory leak checked, run tested, and shipped with a holding charge of R-410A refrigerant.
- Unit cabinet components shall be G90 equivalent steel finished with powder-coat paint rated at a minimum of 500 hours under ASTM B117 testing.
- Unit base pan shall be stamped G90 equivalent steel finished with powder-coat paint rated at a minimum of 500 hours under ASTM B117 testing.
- Units shall have a single corner post opposite the electrical control box and two independently removable steel coil guard panels to optimize cabinet strength and serviceability.
- Units shall have L-shaped stamped sheet metal coil guards with punched and extruded slots for maximum panel durability and stiffness.
- Units shall have a factory installed filter-drier for faster installation and improved system reliability.
- Unit base valves shall be mounted diagonally on the unit base pan with service ports that provide sufficient clearance for low-loss hose fittings.
- Units shall be constructed with a high pressure switch for system protection.
- Units shall be constructed with all badging and labels applied at the factory.

UNIT COMPONENTS

- Compressor shall be hermetic with internal electrical overload protection and internal overpressure protection.
- Compressor shall be mounted on rubber vibration isolators that do not require the removal of transportation clips or brackets.
- Units shall be constructed with scroll compressors.
- Outdoor fan shall be direct drive with vertical air discharge for low sound levels.
- Outdoor fan motor shall be totally enclosed with permanently lubricated ball bearings motors approved for vertical shaft applications.
- Outdoor coil shall be air cooled and constructed of zinc-coated aluminum microchannel construction for small size and low weight.

UNIT WARRANTIES

- Unit manufacturer shall provide a 10-Year compressor warranty without a requirement for unit registration.
- Unit manufacturer shall provide a 5-Year parts warranty without a requirement for unit registration.

TYPICAL INSTALLATION

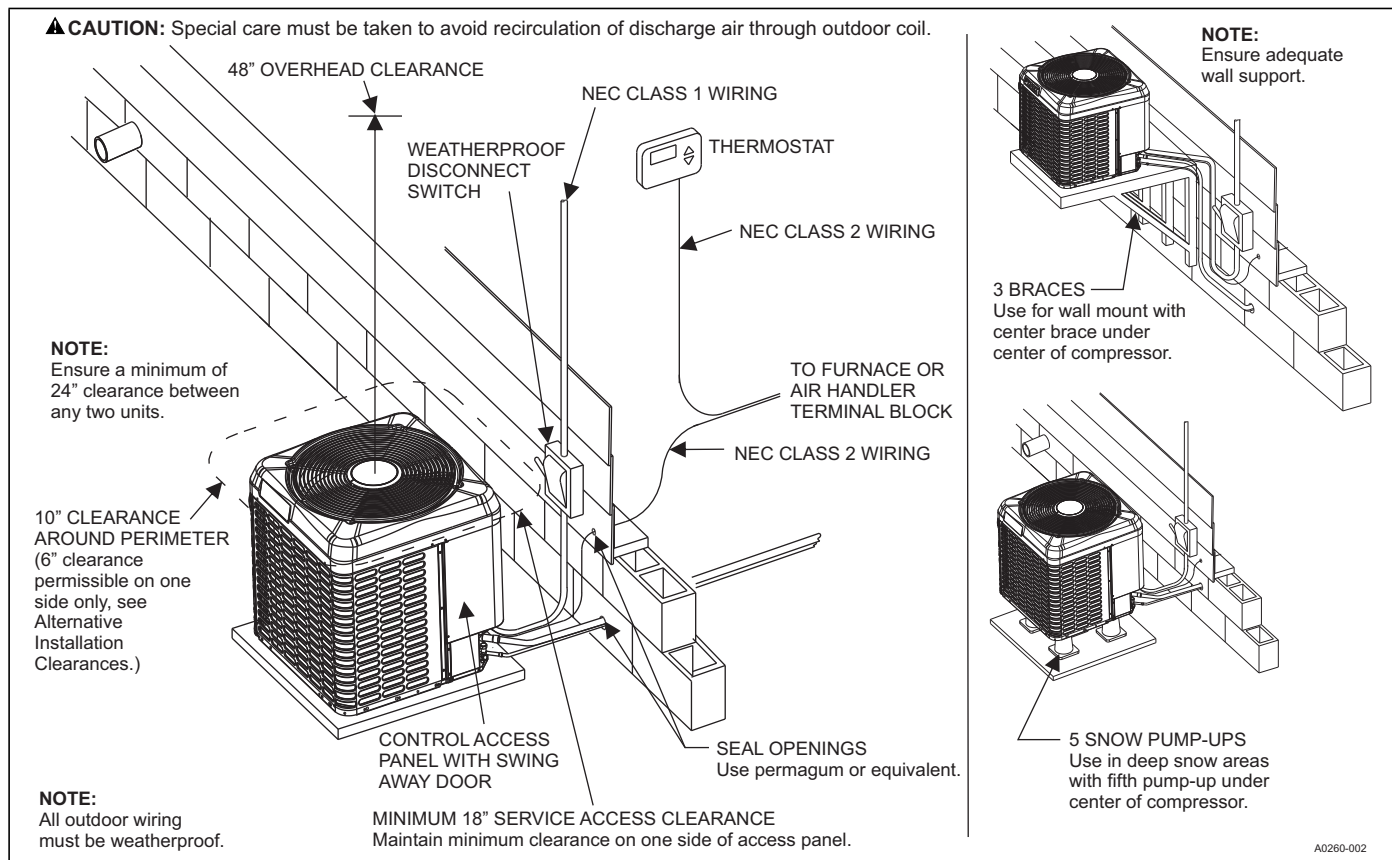

▲ CAUTION

Care must be taken to prevent ice from damaging the unit. Damage may occur from ice falling onto unit from a sloped roof or from a vertical drip line due to a partial overhang.

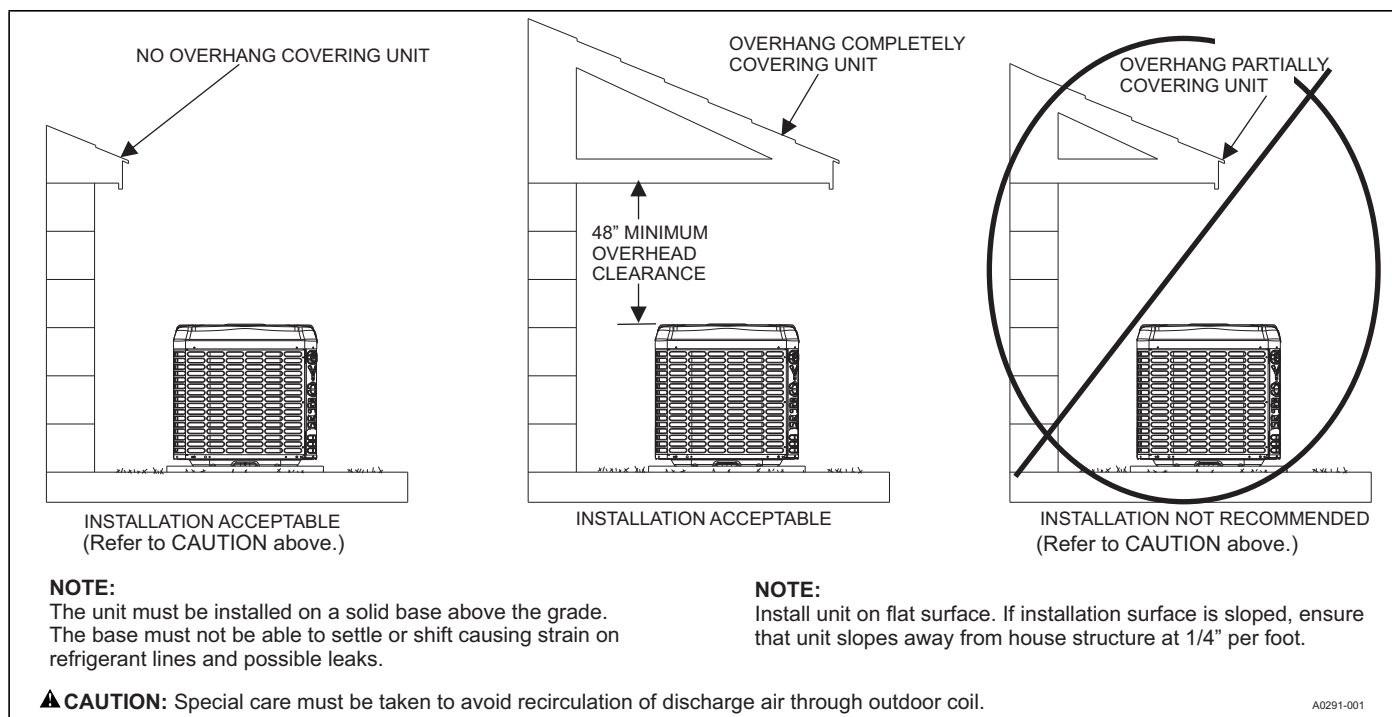

TYPICAL FIELD WIRING

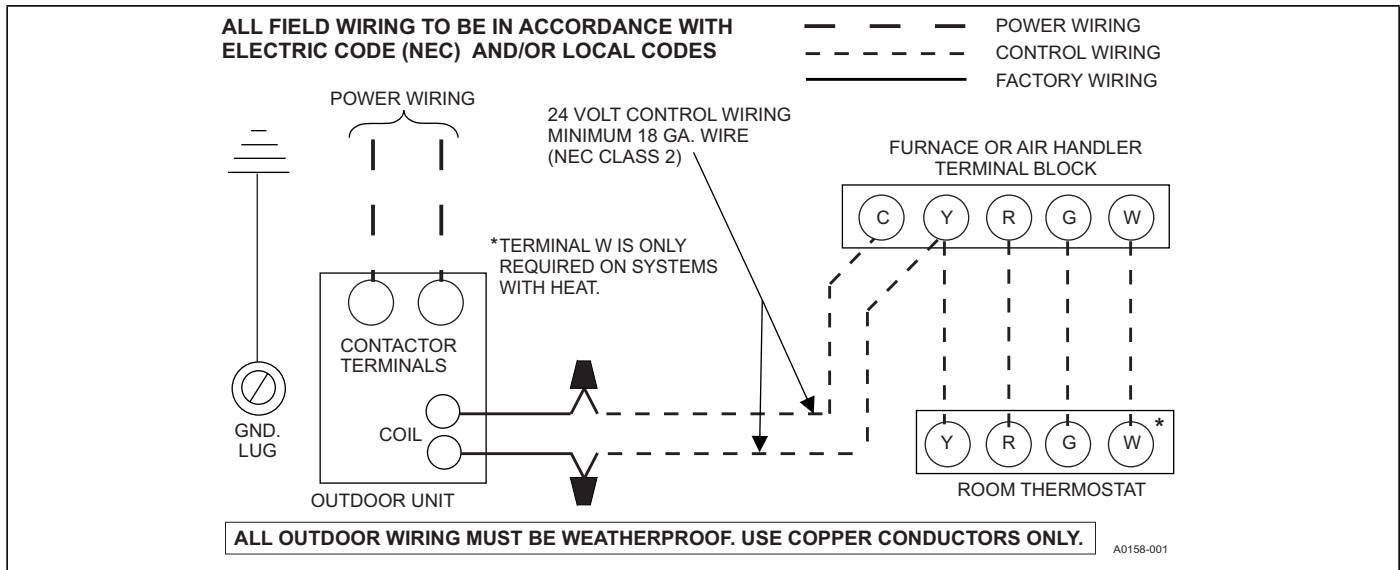

ALTERNATIVE INSTALLATION CLEARANCES

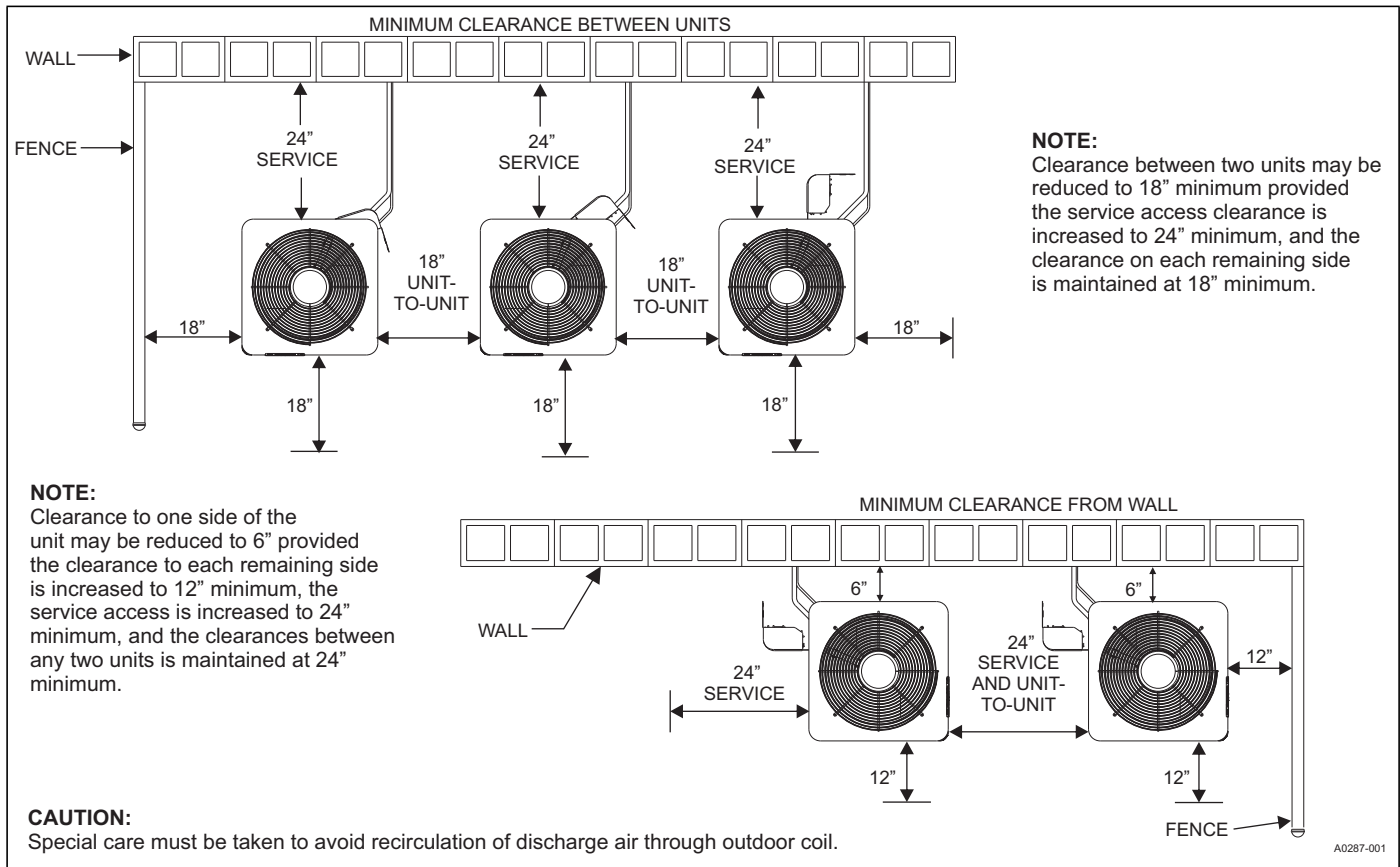

PERFORMANCE DATA - 1.5 TON

CONDENSER-ONLY DATA (OUTDOOR UNIT)																		
MODEL	SATURATED SUCTION @ COMPRESSOR		Outdoor Ambient Temperature															
			55 °F		65 °F		75 °F		85 °F		95 °F		105 °F		115 °F		125 °F	
	T (°F)	P (PSIG)	MBH	KW	MBH	KW	MBH	KW	MBH	KW	MBH	KW	MBH	KW	MBH	KW	MBH	KW
TW4B1821S	35	107	17.0	0.82	16.2	0.94	15.4	1.06	14.5	1.20	13.6	1.35	12.6	1.53	11.6	1.73	10.6	1.96
	40	118	18.8	0.80	17.9	0.92	17.0	1.05	16.0	1.18	15.0	1.33	14.0	1.51	12.9	1.72	11.8	1.95
	45	130	20.7	0.78	19.7	0.90	18.7	1.03	17.7	1.17	16.6	1.32	15.5	1.49	14.3	1.70	13.1	1.93
	50	142	22.8	0.76	21.7	0.88	20.6	1.01	19.5	1.15	18.3	1.30	17.1	1.48	15.8	1.68	14.5	1.90
	55	156	24.9	0.74	23.8	0.86	22.6	0.99	21.3	1.13	20.1	1.28	18.8	1.46	17.4	1.66	16.0	1.88

Notes:

- For Outdoor Unit (Condenser) performance only. Data does not include the effects of air handler power or heat.
- Performance based on 15°F subcooling and 15°F superheat at the Outdoor Unit base valves.
 - Increase capacity by 1% for each 2°F increase in subcooling.
 - Decrease capacity by 1% for each 2°F decrease in subcooling.
- Maximum recommended condensing temperature is 140°F.

COOLING PERFORMANCE DATA																
OUTDOOR UNIT MODEL NO.		TW4B1821S														
INDOOR COIL MODEL NO.		CF18AXA1														
AIR TEMP. ENTERING OUTDOOR UNIT (°F)	ID CFM	450					600					750				
	ID DB (°F)	80	80	75	80	80	80	80	75	80	80	80	80	75	80	80
	ID WB (°F)	57	62	62	67	72	57	62	62	67	72	57	62	62	67	72
55	T.C.	16.0	18.2	18.3	20.3	22.0	17.4	19.1	19.3	21.1	22.6	18.7	20.0	20.2	21.8	23.3
	S.C.	14.6	13.7	11.9	12.0	9.6	16.5	15.8	13.5	13.4	10.4	18.5	17.9	15.1	14.8	11.2
	KW	0.97	0.96	0.95	0.94	0.94	1.02	1.01	1.00	1.00	1.00	1.06	1.06	1.05	1.05	1.05
65	T.C.	15.4	17.5	17.6	19.5	21.3	16.7	18.4	18.5	20.3	22.0	18.1	19.2	19.4	21.1	22.7
	S.C.	14.2	13.3	11.5	11.6	9.3	15.9	15.3	13.0	13.1	10.2	17.6	17.3	14.6	14.6	11.1
	KW	1.07	1.07	1.06	1.05	1.04	1.12	1.11	1.11	1.10	1.09	1.16	1.16	1.16	1.15	1.15
75	T.C.	14.8	16.8	16.9	18.7	20.6	16.1	17.6	17.7	19.6	21.4	17.5	18.4	18.5	20.4	22.2
	S.C.	13.9	12.8	11.1	11.2	9.0	15.4	14.8	12.6	12.8	10.0	16.8	16.7	14.1	14.4	11.0
	KW	1.17	1.17	1.16	1.15	1.14	1.22	1.22	1.21	1.20	1.19	1.26	1.26	1.26	1.25	1.24
85	T.C.	14.5	16.2	16.3	18.0	19.8	15.7	16.9	17.0	18.8	20.5	17.0	17.7	17.8	19.5	21.3
	S.C.	13.7	12.6	10.8	10.9	8.7	15.1	14.5	12.3	12.4	9.7	16.4	16.3	13.8	13.9	10.6
	KW	1.30	1.30	1.30	1.29	1.28	1.35	1.35	1.34	1.34	1.33	1.39	1.39	1.39	1.39	1.38
95	T.C.	14.2	15.6	15.7	17.4	19.0	15.3	16.2	16.4	18.0	19.7	16.5	16.9	17.1	18.6	20.3
	S.C.	13.6	12.4	10.6	10.6	8.5	14.8	14.1	12.1	12.0	9.4	15.9	15.8	13.6	13.4	10.3
	KW	1.43	1.43	1.43	1.43	1.41	1.48	1.48	1.48	1.48	1.46	1.53	1.53	1.53	1.52	1.51
105	T.C.	13.4	14.7	14.8	16.5	18.1	14.6	15.4	15.4	17.0	18.7	15.7	16.0	16.1	17.6	19.3
	S.C.	12.9	12.0	10.2	10.3	8.2	14.1	13.6	11.8	11.7	9.1	15.2	15.2	13.3	13.1	10.0
	KW	1.67	1.66	1.66	1.64	1.62	1.70	1.70	1.70	1.68	1.67	1.74	1.74	1.74	1.73	1.72
115	T.C.	12.7	13.9	13.9	15.6	17.2	13.9	14.6	14.5	16.1	17.7	15.0	15.2	15.1	16.6	18.3
	S.C.	12.3	11.7	9.8	10.0	7.9	13.4	13.1	11.4	11.4	8.8	14.6	14.6	13.0	12.9	9.6
	KW	1.90	1.88	1.88	1.85	1.82	1.92	1.91	1.91	1.89	1.87	1.94	1.94	1.94	1.93	1.92
125	T.C.	11.9	13.1	13.0	14.7	16.3	13.1	13.8	13.6	15.1	16.8	14.3	14.4	14.2	15.6	17.3
	S.C.	11.7	11.3	9.4	9.7	7.6	12.8	12.6	11.1	11.2	8.5	13.9	14.0	12.7	12.6	9.3
	KW	2.14	2.10	2.10	2.05	2.03	2.14	2.12	2.13	2.09	2.07	2.14	2.14	2.15	2.13	2.12

NOTE: ALL CAPACITIES INCLUDE INDOOR FAN HEAT. KW VALUES ARE FOR THE SYSTEM (OUTDOOR + INDOOR).

Green shaded cells are ACCA (TVA) conditions.

Blue shaded cells are AHRI conditions.

Multipliers for determining the performance with other indoor sections.

NOTE: For dry bulb temperatures different than those listed (between 73-87 °F), sensible capacity increases by 1060 BTUH per 1000 CFM per degree above the listed temperature and decreases by 1060 BTUH per 1000 CFM per degree below the listed temperature.

COIL MULTIPLIERS- 1.5 TON

Air Handler	Coil	T.C.	S.C.	KW
-	CF/CM/CU18A	1.00	1.00	1.00
-	CF/CM/CU18B	1.00	1.00	1.00
-	CF/CM/CU24A	1.00	1.00	1.00
-	CF/CM/CU24B	1.00	1.00	1.00
-	CF/CM/CU24C	1.00	1.00	1.00
-	CF/CM/CU30A	1.00	0.99	1.00
-	CF/CM/CU30B	1.00	0.99	1.00
-	CF/CM/CU30C	1.00	0.99	1.00
-	CF/CM/CU30D	1.00	0.99	1.00
-	CF/CM/CU36B	1.00	1.03	1.00
-	CF/CM/CU36C	1.00	1.03	1.00
-	CF/CM/CU36D	1.00	1.03	1.00
-	CF/CM36A	1.00	1.03	1.00
AE18BX21	-	1.00	1.01	0.92
AE24BX21	-	1.00	1.00	0.92
AE30BX21	-	1.00	1.02	0.92
AE36BX21	-	1.00	1.00	0.96
AE36CX21	-	1.00	1.01	0.94
AP18BX21	-	1.00	1.01	0.98
AP24BX21	-	1.00	1.00	1.00
AP30BX21	-	1.00	1.03	1.00
AVC18BX21	-	1.00	1.01	0.92
AVC24BX21	-	1.00	1.01	0.92
AVC30BX21	-	1.00	1.00	0.92
ME08BN21	CF/CM18B	1.00	1.01	0.92
ME08BN21	CF/CM24B	1.00	1.02	0.92
ME08BN21	CF/CM30B	1.00	1.00	0.92
ME08BN21	CF/CM36B	1.00	1.03	0.92
ME12BN21	CF/CM18B	1.00	1.01	0.98
ME12BN21	CF/CM24B	1.00	1.03	0.98
ME12BN21	CF/CM30B	1.00	1.02	0.96
ME12BN21	CF/CM36B	1.00	1.04	0.94
MVC08BN21	CF/CM18B	1.00	0.98	0.92
MVC08BN21	CF/CM24B	1.00	1.00	0.92
MVC08BN21	CF/CM30B	1.00	1.00	0.92
MVC12BN21	CF/CM36B	1.00	1.04	0.92

FURNACE MULTIPLIERS- 1.5 TON

Furnaces	Coil	T.C.	S.C.	KW
TL8E060A12UH11	CF/CM/CU18A	1.00	1.17	0.92
TL8E060A12UH11	CF/CM/CU18B	1.00	1.24	0.92
TL8E060A12UH11	CF/CM/CU24A	1.00	1.17	0.92
TL8E060A12UH11	CF/CM/CU24B	1.00	1.22	0.92
TL8E060A12UH11	CF/CM/CU30A	1.00	1.16	0.92
TL8E060A12UH11	CF/CM/CU30B	1.00	1.24	0.92
TL8E060A12UH11	CF/CM/CU36B	1.00	1.23	0.92
TL8E060A12UH11	CF/CM36A	1.00	1.19	0.92
TL9E060B12UH11	CF/CM/CU18B	1.00	1.21	0.92
TL9E060B12UH11	CF/CM/CU24B	1.00	1.22	0.92
TL9E060B12UH11	CF/CM/CU30B	1.00	1.17	0.92
TL9E060B12UH11	CF/CM/CU36B	1.00	1.21	0.92
TL9E060B12UH11	CF/CM/CU36C	1.00	1.23	0.92

FURNACE MULTIPLIERS- 1.5 TON (Continued)

Furnaces	Coil	T.C.	S.C.	KW
TL9E060B12UH11	CF/CM24C	1.00	1.22	0.92
TL9E060B12UH11	CF/CM30C	1.00	1.24	0.92
TM8E040A12MP11	CF/CM/CU18A	1.00	1.28	0.94
TM8E040A12MP11	CF/CM/CU18B	1.00	1.23	0.92
TM8E040A12MP11	CF/CM/CU24A	1.00	1.22	0.92
TM8E040A12MP11	CF/CM/CU24B	1.00	1.25	0.92
TM8E040A12MP11	CF/CM/CU30A	1.00	1.17	0.92
TM8E040A12MP11	CF/CM/CU30B	1.00	1.23	0.92
TM8E040A12MP11	CF/CM/CU36B	1.00	1.23	0.92
TM8E040A12MP11	CF/CM36A	1.00	1.25	0.92
TM8E060A12MP11	CF/CM/CU18A	1.00	1.28	0.94
TM8E060A12MP11	CF/CM/CU24A	1.00	1.27	0.92
TM8E060A12MP11	CF/CM/CU30A	1.00	1.27	0.92
TM8E060A12MP11	CF/CM36A	1.00	1.25	0.92
TM8E080B12MP11	CF/CM/CU18B	1.00	1.28	0.92
TM8E080B12MP11	CF/CM/CU24B	1.00	1.27	0.92
TM8E080B12MP11	CF/CM/CU30B	1.00	1.27	0.92
TM8E080B12MP11	CF/CM/CU36B	1.00	1.25	0.92
TM8E100B12MP11	CF/CM/CU18B	1.00	1.24	0.92
TM8E100B12MP11	CF/CM/CU24B	1.00	1.27	0.92
TM8E100B12MP11	CF/CM/CU30B	1.00	1.27	0.92
TM8E100B12MP11	CF/CM/CU36B	1.00	1.25	0.92
TM8E100B12MP11	CF/CM/CU36C	1.00	1.25	0.92
TM8E100B12MP11	CF/CM24C	1.00	1.27	0.92
TM8E100B12MP11	CF/CM30C	1.00	1.27	0.92
TM8V060A12MP11C	CF/CM/CU18A	1.00	1.16	0.94
TM8V060A12MP11C	CF/CM/CU24A	1.00	1.15	0.92
TM8V060A12MP11C	CF/CM/CU30A	1.00	1.17	0.92
TM8V060A12MP12C	CF/CM/CU18A	1.00	1.16	0.94
TM8V060A12MP12C	CF/CM/CU24A	1.00	1.15	0.92
TM8V060A12MP12C	CF/CM/CU30A	1.00	1.17	0.92
TM8V060A12MP12C	CF/CM36A	1.00	1.19	0.92
TM8V080B12MP11C	CF/CM/CU18B	1.00	1.19	0.94
TM8V080B12MP11C	CF/CM/CU24B	1.00	1.19	0.92
TM8V080B12MP11C	CF/CM/CU30B	1.00	1.17	0.92
TM8V080B12MP11C	CF/CM/CU36B	1.00	1.19	0.92
TM8V080B12MP12C	CF/CM/CU18B	1.00	1.19	0.94
TM8V080B12MP12C	CF/CM/CU24B	1.00	1.19	0.92
TM8V080B12MP12C	CF/CM/CU30B	1.00	1.17	0.92
TM8V080B12MP12C	CF/CM/CU36B	1.00	1.19	0.92
TM8X060A12MP11	CF/CM/CU18A	1.00	1.00	0.96
TM8X060A12MP11	CF/CM/CU24A	1.00	1.01	0.94
TM8X060A12MP11	CF/CM/CU30A	1.00	1.17	0.92
TM8X060A12MP11	CF/CM36A	1.00	1.19	0.92
TM8X080B12MP11	CF/CM/CU18B	1.00	1.01	0.94
TM8X080B12MP11	CF/CM/CU24B	1.00	1.01	0.94
TM8X080B12MP11	CF/CM/CU30B	1.00	0.99	0.92
TM8X080B12MP11	CF/CM/CU36B	1.00	1.02	0.92
TM8X080C16MP11	CF/CM/CU24C	1.00	1.24	0.92
TM8X080C16MP11	CF/CM/CU30C	1.00	1.23	0.92
TM8X080C16MP11	CF/CM/CU36C	1.00	1.23	0.92
TM8X080C16MP11	CF/CM24C	1.00	1.25	0.92
TM8X080C16MP11	CF/CM30C	1.00	1.24	0.92
TM8X080C16MP11	CF/CM36D	1.00	1.02	0.92
TM8X100C16MP11	CF/CM/CU24C	1.00	1.24	0.92
TM8X100C16MP11	CF/CM/CU30C	1.00	1.23	0.92

FURNACE MULTIPLIERS- 1.5 TON (Continued)

Furnaces	Coil	T.C.	S.C.	KW
TM8X100C16MP11	CF/CM/CU36C	1.00	1.23	0.92
TM8X100C16MP11	CF/CM24C	1.00	1.25	0.92
TM8X100C16MP11	CF/CM30C	1.00	1.24	0.92
TM8Y060A12MP11	CF/CM/CU18A	1.00	1.00	0.96
TM8Y060A12MP11	CF/CM/CU24A	1.00	1.01	0.94
TM8Y060A12MP11	CF/CM/CU30A	1.00	1.17	0.92
TM8Y060A12MP11	CF/CM36A	1.00	1.19	0.92
TM8Y080B12MP11	CF/CM/CU18B	1.00	1.01	0.94
TM8Y080B12MP11	CF/CM/CU24B	1.00	1.01	0.94
TM8Y080B12MP11	CF/CM/CU30B	1.00	0.99	0.92
TM8Y080B12MP11	CF/CM/CU36B	1.00	1.02	0.92
TM8Y080C16MP11	CF/CM/CU24C	1.00	1.24	0.92
TM8Y080C16MP11	CF/CM/CU30C	1.00	1.23	0.92
TM8Y080C16MP11	CF/CM/CU36C	1.00	1.23	0.92
TM8Y080C16MP11	CF/CM24C	1.00	1.25	0.92
TM8Y080C16MP11	CF/CM30C	1.00	1.24	0.92
TM8Y080C16MP11	CF/CM36D	1.00	1.02	0.92
TM8Y100C16MP11	CF/CM/CU24C	1.00	1.24	0.92
TM8Y100C16MP11	CF/CM/CU30C	1.00	1.23	0.92
TM8Y100C16MP11	CF/CM/CU36C	1.00	1.23	0.92
TM8Y100C16MP11	CF/CM24C	1.00	1.25	0.92
TM8Y100C16MP11	CF/CM30C	1.00	1.24	0.92
TM8Y100C16MP11	CF/CM36D	1.00	1.02	0.92
TM9E040A10MP11	CF/CM/CU18A	1.00	1.01	0.94
TM9E040A10MP11	CF/CM/CU24A	0.98	1.07	0.94
TM9E040A10MP11	CF/CM/CU30A	0.99	1.08	0.95
TM9E040A10MP11	CF/CM36A	1.00	1.08	0.94
TM9E040A10MP12	CF/CM/CU18A	1.00	1.16	0.96
TM9E040A10MP12	CF/CM/CU18B	1.00	1.19	0.96
TM9E040A10MP12	CF/CM/CU24A	1.00	1.17	0.94
TM9E040A10MP12	CF/CM/CU24B	1.00	1.19	0.94
TM9E040A10MP12	CF/CM/CU30A	1.00	1.16	0.94
TM9E040A10MP12	CF/CM/CU30B	1.00	1.17	0.92
TM9E040A10MP12	CF/CM/CU36B	1.00	1.19	0.92
TM9E040A10MP12	CF/CM36A	1.00	1.16	0.92
TM9E060A10MP12	CF/CM/CU18A	1.00	1.23	0.96
TM9E060A10MP12	CF/CM/CU18B	1.00	1.24	0.94
TM9E060A10MP12	CF/CM/CU24A	1.00	1.23	0.94
TM9E060A10MP12	CF/CM/CU24B	1.00	1.25	0.94
TM9E060A10MP12	CF/CM/CU30A	1.00	1.23	0.92
TM9E060A10MP12	CF/CM/CU30B	1.00	1.24	0.92
TM9E060A10MP12	CF/CM/CU36B	1.00	1.23	0.92
TM9E060A10MP12	CF/CM36A	1.00	1.22	0.92
TM9E060B12MP11	CF/CM/CU18B	1.00	1.23	0.96
TM9E060B12MP11	CF/CM/CU24B	1.00	1.23	0.96
TM9E060B12MP11	CF/CM/CU30B	1.00	1.23	0.94
TM9E060B12MP11	CF/CM/CU36B	1.00	1.02	0.92
TM9E060B12MP11	CF/CM/CU36C	1.00	1.23	0.92
TM9E060B12MP11	CF/CM24C	1.00	1.23	0.96
TM9E060B12MP11	CF/CM30C	1.00	1.23	0.94
TM9E080B12MP11	CF/CM/CU18B	1.00	1.01	0.96
TM9E080B12MP11	CF/CM/CU24B	1.00	1.25	0.94
TM9E080B12MP11	CF/CM/CU30B	1.00	1.00	0.94
TM9E080B12MP11	CF/CM/CU36B	1.00	1.23	0.92
TM9E080C16MP11	CF/CM/CU36C	1.00	1.02	0.92
TM9E080C16MP11	CF/CM24C	1.00	1.17	0.92

FURNACE MULTIPLIERS- 1.5 TON (Continued)

Furnaces	Coil	T.C.	S.C.	KW
TM9E080C16MP11	CF/CM30C	1.00	1.16	0.92
TM9E080C16MP11	CF/CM36D	1.00	1.17	0.92
TM9E100C16MP11	CF/CM/CU24C	1.00	1.19	0.92
TM9E100C16MP11	CF/CM/CU30C	1.00	1.16	0.92
TM9E100C16MP11	CF/CM/CU30D	1.00	1.18	0.92
TM9E100C16MP11	CF/CM/CU36C	1.00	1.21	0.92
TM9E100C16MP11	CF/CM/CU36D	1.00	1.20	0.92
TM9E100C16MP11	CF/CM24C	1.00	1.19	0.92
TM9E100C16MP11	CF/CM30C	1.00	1.17	0.92
TM9E100C16MP11	CF/CM36D	1.00	1.21	0.92
TM9E100C20MP11	CF/CM/CU36C	1.00	1.01	0.98
TM9V040A10MP11C	CF/CM/CU18A	1.00	1.11	0.98
TM9V040A10MP11C	CF/CM/CU18B	1.00	1.11	0.98
TM9V040A10MP11C	CF/CM/CU24A	1.00	1.10	0.98
TM9V040A10MP11C	CF/CM/CU24B	1.00	1.15	0.96
TM9V040A10MP11C	CF/CM/CU30A	1.00	1.12	0.96
TM9V040A10MP11C	CF/CM/CU30B	1.00	1.17	0.94
TM9V040A10MP11C	CF/CM/CU36B	1.00	1.11	0.94
TM9V040A10MP11C	CF/CM36A	1.00	1.11	0.94
TM9V040A10MP12C	CF/CM/CU18A	1.00	1.11	0.98
TM9V040A10MP12C	CF/CM/CU18B	1.00	1.11	0.98
TM9V040A10MP12C	CF/CM/CU24A	1.00	1.10	0.98
TM9V040A10MP12C	CF/CM/CU24B	1.00	1.15	0.96
TM9V040A10MP12C	CF/CM/CU30A	1.00	1.12	0.96
TM9V040A10MP12C	CF/CM/CU30B	1.00	1.17	0.94
TM9V040A10MP12C	CF/CM/CU36B	1.00	1.11	0.94
TM9V040A10MP12C	CF/CM36A	1.00	1.11	0.94
TM9V060B12MP11C	CF/CM/CU18B	1.00	1.17	0.96
TM9V060B12MP11C	CF/CM/CU24B	1.00	1.17	0.92
TM9V060B12MP11C	CF/CM/CU30B	1.00	1.16	0.92
TM9V060B12MP11C	CF/CM/CU36B	1.00	1.02	0.92
TM9V060B12MP11C	CF/CM/CU36C	1.00	1.23	0.92
TM9V060B12MP11C	CF/CM24C	1.00	1.17	0.92
TM9V060B12MP11C	CF/CM30C	1.00	1.16	0.92
TM9V060B12MP12C	CF/CM/CU18B	1.00	1.17	0.96
TM9V060B12MP12C	CF/CM/CU24B	1.00	1.17	0.92
TM9V060B12MP12C	CF/CM/CU30B	1.00	1.16	0.92
TM9V060B12MP12C	CF/CM/CU36B	1.00	1.23	0.92
TM9V060B12MP12C	CF/CM/CU36C	1.00	1.23	0.92
TM9V060B12MP12C	CF/CM24C	1.00	1.17	0.92
TM9V060B12MP12C	CF/CM30C	1.00	1.16	0.92
TM9V080B12MP11C	CF/CM/CU18B	1.00	1.16	0.94
TM9V080B12MP11C	CF/CM/CU24B	1.00	1.15	0.92
TM9V080B12MP11C	CF/CM/CU30B	1.00	1.17	0.92
TM9V080B12MP11C	CF/CM/CU36B	1.00	1.19	0.92
TM9V080B12MP12C	CF/CM/CU18B	1.00	1.16	0.94
TM9V080B12MP12C	CF/CM/CU24B	1.00	1.15	0.92
TM9V080B12MP12C	CF/CM/CU30B	1.00	1.17	0.92
TM9V080B12MP12C	CF/CM/CU36B	1.00	1.19	0.92
TM9Y040A10MP11	CF/CM/CU18A	0.98	1.08	0.94
TM9Y040A10MP11	CF/CM/CU24A	0.98	1.07	0.94
TM9Y040A10MP11	CF/CM/CU30A	0.99	1.08	0.95
TM9Y040A10MP11	CF/CM36A	1.00	1.08	0.94
TM9Y060B12MP11	CF/CM/CU18B	1.00	1.23	0.96
TM9Y060B12MP11	CF/CM/CU24B	1.00	1.23	0.96

PERFORMANCE DATA - 2 TON

CONDENSER-ONLY DATA (OUTDOOR UNIT)																		
MODEL	SATURATED SUCTION @ COMPRESSOR		Outdoor Ambient Temperature															
			55 °F		65 °F		75 °F		85 °F		95 °F		105 °F		115 °F		125 °F	
	T (°F)	P (PSIG)	MBH	KW	MBH	KW	MBH	KW	MBH	KW	MBH	KW	MBH	KW	MBH	KW	MBH	KW
TW4B2421S	35	107	23.4	1.10	22.2	1.25	21.1	1.41	19.9	1.59	18.6	1.80	17.3	2.04	15.9	2.33	14.5	2.67
	40	118	25.8	1.08	24.5	1.24	23.3	1.40	22.0	1.58	20.7	1.78	19.2	2.02	17.7	2.31	16.2	2.63
	45	130	28.3	1.06	27.0	1.22	25.7	1.38	24.3	1.56	22.8	1.76	21.3	2.00	19.7	2.28	17.9	2.60
	50	142	31.1	1.04	29.7	1.20	28.2	1.37	26.7	1.55	25.1	1.74	23.4	1.98	21.7	2.26	19.9	2.57
	55	156	34.0	1.01	32.5	1.18	30.9	1.35	29.2	1.53	27.5	1.73	25.7	1.96	23.9	2.24	21.9	2.54

Notes:

- For Outdoor Unit (Condenser) performance only. Data does not include the effects of air handler power or heat.
- Performance based on 15°F subcooling and 15°F superheat at the Outdoor Unit base valves.
 - Increase capacity by 1% for each 2°F increase in subcooling.
 - Decrease capacity by 1% for each 2°F decrease in subcooling.
- Maximum recommended condensing temperature is 140°F.

COOLING PERFORMANCE DATA																
OUTDOOR UNIT MODEL NO.		TW4B2421S														
INDOOR COIL MODEL NO.		CF24AXA1														
AIR TEMP. ENTERING OUTDOOR UNIT (°F)	ID CFM	600					800					1000				
	ID DB (°F)	80	80	75	80	80	80	80	75	80	80	80	80	75	80	80
	ID WB (°F)	57	62	62	67	72	57	62	62	67	72	57	62	62	67	72
55	T.C.	22.1	24.3	24.5	26.6	28.5	23.8	25.3	25.4	27.5	28.9	25.4	26.4	26.4	28.4	29.4
	S.C.	21.7	19.3	16.5	16.3	13.0	23.7	21.8	18.5	18.0	13.8	25.4	24.4	20.5	19.6	14.5
	KW	1.27	1.26	1.26	1.25	1.24	1.33	1.33	1.33	1.32	1.32	1.39	1.39	1.39	1.39	1.39
65	T.C.	21.3	23.0	23.7	25.9	28.0	23.0	24.2	24.6	26.8	28.6	24.7	25.5	25.5	27.7	29.3
	S.C.	20.9	19.2	15.9	15.8	12.8	22.8	21.5	18.0	17.7	13.8	24.7	23.9	20.1	19.6	14.8
	KW	1.41	1.41	1.40	1.39	1.38	1.47	1.47	1.46	1.46	1.45	1.53	1.53	1.53	1.53	1.52
75	T.C.	20.4	21.6	22.8	25.2	27.6	22.2	23.1	23.8	26.1	28.4	24.0	24.6	24.7	27.0	29.2
	S.C.	20.1	19.1	15.3	15.3	12.5	22.0	21.2	17.6	17.5	13.8	24.0	23.4	19.8	19.7	15.0
	KW	1.55	1.57	1.53	1.52	1.52	1.61	1.62	1.60	1.59	1.58	1.67	1.68	1.66	1.66	1.65
85	T.C.	19.7	20.5	21.9	24.2	26.4	21.4	22.0	22.7	25.0	27.2	23.2	23.6	23.6	25.9	28.1
	S.C.	19.4	19.0	15.0	15.0	12.1	21.3	20.9	17.2	17.2	13.4	23.1	22.9	19.3	19.3	14.7
	KW	1.74	1.79	1.72	1.71	1.70	1.80	1.83	1.79	1.78	1.77	1.86	1.87	1.86	1.85	1.83
95	T.C.	19.0	19.3	20.9	23.2	25.2	20.7	20.9	21.7	24.0	26.1	22.3	22.5	22.5	24.8	27.0
	S.C.	18.8	18.9	14.6	14.6	11.7	20.5	20.6	16.7	16.8	13.0	22.3	22.4	18.9	19.0	14.3
	KW	1.93	2.02	1.92	1.90	1.89	1.99	2.04	1.98	1.97	1.95	2.04	2.06	2.05	2.03	2.01
105	T.C.	18.1	18.6	19.5	21.7	23.2	19.6	19.9	20.3	22.4	24.3	21.1	21.2	21.0	23.1	25.3
	S.C.	17.8	17.7	14.0	14.0	11.5	19.4	19.4	16.0	16.1	12.6	21.0	21.2	18.0	18.2	13.7
	KW	2.31	2.38	2.33	2.27	2.23	2.35	2.39	2.36	2.32	2.29	2.39	2.39	2.40	2.37	2.34
115	T.C.	17.1	17.8	18.1	20.2	21.3	18.5	18.9	18.9	20.9	22.5	19.9	19.9	19.6	21.5	23.7
	S.C.	16.9	16.6	13.4	13.4	11.2	18.4	18.3	15.3	15.5	12.2	19.8	19.9	17.2	17.5	13.1
	KW	2.67	2.73	2.73	2.63	2.57	2.70	2.72	2.73	2.67	2.61	2.73	2.71	2.74	2.71	2.66
125	T.C.	16.2	17.1	16.8	18.7	19.4	17.4	17.9	17.5	19.3	20.8	18.6	18.6	18.1	19.9	22.1
	S.C.	16.0	15.4	12.7	12.8	10.9	17.4	17.2	14.6	14.8	11.7	18.6	18.6	16.4	16.7	12.5
	KW	3.03	3.07	3.12	2.99	2.91	3.05	3.05	3.10	3.01	2.94	3.06	3.04	3.09	3.04	2.98

NOTE: ALL CAPACITIES INCLUDE INDOOR FAN HEAT. KW VALUES ARE FOR THE SYSTEM (OUTDOOR + INDOOR).

Green shaded cells are ACCA (TVA) conditions.

Blue shaded cells are AHRI conditions.

Multipliers for determining the performance with other indoor sections.

NOTE: For dry bulb temperatures different than those listed (between 73-87 °F), sensible capacity increases by 1060 BTUH per 1000 CFM per degree above the listed temperature and decreases by 1060 BTUH per 1000 CFM per degree below the listed temperature.

COIL MULTIPLIERS- 2 TON

Air Handler	Coil	T.C.	S.C.	KW
-	CF/CM/CU24A	1.00	1.00	1.00
-	CF/CM/CU24B	1.00	1.00	1.00
-	CF/CM/CU24C	1.00	1.00	1.00
-	CF/CM/CU30A	1.00	1.00	1.00
-	CF/CM/CU30B	1.00	1.00	1.00
-	CF/CM36A	1.00	0.98	1.00
-	CF42B	1.00	1.00	1.00
AE24BX21	-	1.00	1.00	0.92
AE30BX21	-	1.00	1.00	0.92
AE36BX21	-	1.00	1.00	0.92
AE36CX21	-	1.00	1.00	0.92
AP24BX21	-	1.00	1.00	1.00
AP30BX21	-	1.00	0.99	0.98
AP36BX21	-	1.00	1.04	1.00
AP36CX21	-	1.00	1.01	0.98
AVC24BX21	-	1.00	0.98	0.94
AVC30BX21	-	1.00	0.99	0.92
AVC36BX21	-	1.00	0.99	0.92
AVC36CX21	-	1.00	1.00	0.92
ME08BN21	CF/CM24B	1.00	1.00	0.92
ME08BN21	CF/CM30B	1.00	1.01	0.92
ME08BN21	CF/CM36B	1.00	0.99	0.92
ME08BN21	CF42B	1.00	1.00	0.92
ME12BN21	CF/CM24B	1.00	1.00	0.94
ME12BN21	CF/CM30B	1.00	1.00	0.92
ME12BN21	CF/CM36B	1.00	0.99	0.92
ME12BN21	CF42B	1.00	1.00	0.92
ME14DN21	CF/CM30D	1.00	1.00	0.94
ME14DN21	CF/CM36D	1.00	0.99	0.94
ME14DN21	CF/CM42D	1.00	1.00	0.94
ME16CN21	CF/CM24C	1.00	1.04	0.98
MVC08BN21	CF/CM24B	1.00	1.00	0.92
MVC08BN21	CF/CM30B	1.00	0.96	0.92
MVC08BN21	CF/CM36B	1.00	0.99	0.92
MVC08BN21	CF42B	1.00	1.00	0.92
MVC12BN21	CF/CM24B	1.00	1.00	0.94
MVC12BN21	CF/CM30B	1.00	1.02	0.92
MVC12BN21	CF/CM36B	1.00	0.99	0.92
MVC12BN21	CF42B	1.00	1.00	0.92
MVC14DN21	CF/CM30D	1.00	1.00	0.92
MVC14DN21	CF/CM36D	1.00	1.02	0.92
MVC14DN21	CF/CM42D	1.00	1.00	0.92
MVC16CN21	CF/CM42C	1.00	1.04	0.92

FURNACE MULTIPLIERS- 2 TON

Furnaces	Coil	T.C.	S.C.	KW
TL8E060A12UH11	CF/CM/CU24A	1.00	1.02	0.96
TL8E060A12UH11	CF/CM/CU24B	1.00	1.05	0.94
TL8E060A12UH11	CF/CM/CU30A	1.00	1.05	0.92
TL8E060A12UH11	CF/CM/CU30B	1.00	1.07	0.92
TL8E060A12UH11	CF/CM/CU36B	1.00	1.04	0.92
TL8E060A12UH11	CF/CM36A	1.00	1.01	0.92
TL8E060A12UH11	CF42B	1.00	1.14	0.92
TL8E080C16UH11	CF/CM24C	1.00	1.14	0.96

FURNACE MULTIPLIERS- 2 TON (Continued)

Furnaces	Coil	T.C.	S.C.	KW
TL9E060B12UH11	CF/CM/CU24B	1.00	1.02	0.94
TL9E060B12UH11	CF/CM/CU30B	1.00	1.06	0.92
TL9E060B12UH11	CF/CM/CU36B	1.00	1.01	0.92
TL9E060B12UH11	CF/CM/CU36C	1.00	1.04	0.92
TL9E060B12UH11	CF/CM/CU42C	1.00	1.05	0.92
TL9E060B12UH11	CF/CM24C	1.00	1.05	0.96
TL9E060B12UH11	CF/CM30C	1.00	1.07	0.92
TL9E060B12UH11	CF42B	1.00	1.04	0.92
TL9E080C16UH11	CF/CM/CU36C	1.00	1.17	0.92
TL9E080C16UH11	CF/CM/CU42C	1.00	1.18	0.92
TL9E080C16UH11	CF/CM24C	1.00	1.11	0.96
TL9E080C16UH11	CF/CM30C	1.00	1.18	0.92
TL9E080C16UH11	CF/CM36D	1.00	1.17	0.92
TL9E080C16UH11	CF/CM42D	1.00	1.18	0.92
TM8E040A12MP11	CF/CM/CU24A	1.00	1.02	0.94
TM8E040A12MP11	CF/CM/CU24B	1.00	1.09	0.94
TM8E040A12MP11	CF/CM/CU30A	1.00	1.11	0.94
TM8E040A12MP11	CF/CM/CU30B	1.00	1.09	0.92
TM8E040A12MP11	CF/CM/CU36B	1.00	1.08	0.92
TM8E040A12MP11	CF/CM36A	1.00	1.06	0.92
TM8E040A12MP11	CF42B	1.00	1.08	0.92
TM8E060A12MP11	CF/CM/CU24A	1.00	1.06	0.94
TM8E060A12MP11	CF/CM/CU24B	1.00	1.07	0.94
TM8E060A12MP11	CF/CM/CU30A	1.00	1.09	0.94
TM8E060A12MP11	CF/CM/CU30B	1.00	1.11	0.92
TM8E060A12MP11	CF/CM/CU36B	1.00	1.11	0.92
TM8E060A12MP11	CF/CM36A	1.00	1.06	0.92
TM8E060A12MP11	CF42B	1.00	1.13	0.92
TM8E080B12MP11	CF/CM/CU24B	1.00	1.06	0.94
TM8E080B12MP11	CF/CM/CU30B	1.00	1.07	0.92
TM8E080B12MP11	CF/CM/CU36B	1.00	1.06	0.92
TM8E080B12MP11	CF/CM/CU36C	1.00	1.07	0.92
TM8E080B12MP11	CF/CM/CU42C	1.00	1.07	0.92
TM8E080B12MP11	CF/CM24C	1.00	1.07	0.94
TM8E080B12MP11	CF/CM30C	1.00	1.08	0.92
TM8E080B12MP11	CF42B	1.00	1.07	0.92
TM8E080C16MP11	CF/CM/CU36C	1.00	1.11	0.92
TM8E080C16MP11	CF/CM/CU42C	1.00	1.13	0.92
TM8E080C16MP11	CF/CM24C	1.00	1.13	0.92
TM8E080C16MP11	CF/CM30C	1.00	1.11	0.92
TM8E080C16MP11	CF/CM36D	1.00	1.11	0.92
TM8E080C16MP11	CF/CM42D	1.00	1.13	0.92
TM8E100B12MP11	CF/CM/CU24B	1.00	1.06	0.94
TM8E100B12MP11	CF/CM/CU30B	1.00	1.07	0.92
TM8E100B12MP11	CF/CM/CU36B	1.00	1.06	0.92
TM8E100B12MP11	CF/CM/CU36C	1.00	1.13	0.92
TM8E100B12MP11	CF/CM/CU42C	1.00	1.13	0.92
TM8E100B12MP11	CF/CM24C	1.00	1.06	0.94
TM8E100B12MP11	CF/CM30C	1.00	1.14	0.92
TM8E100B12MP11	CF42B	1.00	1.13	0.92
TM8E100C16MP11	CF/CM/CU36C	1.00	1.10	0.92
TM8E100C16MP11	CF/CM/CU42C	1.00	1.11	0.92
TM8E100C16MP11	CF/CM24C	1.00	1.11	0.92
TM8E100C16MP11	CF/CM30C	1.00	1.19	0.92
TM8E100C16MP11	CF/CM36D	1.00	1.10	0.92

FURNACE MULTIPLIERS- 2 TON (Continued)

Furnaces	Coil	T.C.	S.C.	KW
TM8E100C16MP11	CF/CM42D	1.00	1.11	0.92
TM8E120C16MP11	CF/CM/CU36C	1.00	1.11	0.92
TM8E120C16MP11	CF/CM/CU42C	1.00	1.13	0.92
TM8E120C16MP11	CF/CM24C	1.00	1.11	0.92
TM8E120C16MP11	CF/CM30C	1.00	1.11	0.92
TM8E120C16MP11	CF/CM36D	1.00	1.11	0.92
TM8E120C16MP11	CF/CM42D	1.00	1.13	0.92
TM8V060A12MP12C	CF/CM/CU24A	1.00	1.10	0.98
TM8V060A12MP12C	CF/CM/CU30A	1.00	1.11	0.96
TM8V060A12MP12C	CF/CM36A	1.00	1.10	0.92
TM8V080B12MP12C	CF/CM/CU24B	1.00	1.12	0.96
TM8V080B12MP12C	CF/CM/CU30B	1.00	1.11	0.94
TM8V080B12MP12C	CF/CM/CU36B	1.00	1.11	0.94
TM8V080B12MP12C	CF42B	1.00	1.13	0.92
TM8V080C16MP12C	CF/CM/CU30C	1.00	1.15	0.92
TM8V080C16MP12C	CF/CM/CU30D	1.00	1.15	0.92
TM8V080C16MP12C	CF/CM/CU36C	1.00	1.14	0.92
TM8V080C16MP12C	CF/CM/CU36D	1.00	1.14	0.92
TM8V080C16MP12C	CF/CM/CU42C	1.00	1.14	0.92
TM8V080C16MP12C	CF/CM/CU42D	1.00	1.14	0.92
TM8V100C16MP12C	CF/CM/CU30C	1.00	1.15	0.92
TM8V100C16MP12C	CF/CM/CU30D	1.00	1.15	0.92
TM8V100C16MP12C	CF/CM/CU36C	1.00	1.14	0.92
TM8V100C16MP12C	CF/CM/CU36D	1.00	1.14	0.92
TM8V100C16MP12C	CF/CM/CU42C	1.00	1.14	0.92
TM8V100C16MP12C	CF/CM/CU42D	1.00	1.14	0.92
TM8X060A12MP11	CF/CM/CU24A	1.00	1.08	0.94
TM8X060A12MP11	CF/CM/CU30A	1.00	1.08	0.92
TM8X060A12MP11	CF/CM36A	1.00	1.08	0.92
TM8X080B12MP11	CF/CM/CU24B	1.00	1.09	0.94
TM8X080B12MP11	CF/CM/CU30B	1.00	1.11	0.92
TM8X080B12MP11	CF/CM/CU36B	1.00	1.08	0.92
TM8X080B12MP11	CF42B	1.00	1.13	0.92
TM8X080C16MP11	CF/CM/CU24C	1.00	1.05	0.92
TM8X080C16MP11	CF/CM/CU30C	1.00	1.07	0.92
TM8X080C16MP11	CF/CM/CU30D	1.00	1.07	0.92
TM8X080C16MP11	CF/CM/CU36C	1.00	1.04	0.92
TM8X080C16MP11	CF/CM/CU36D	1.00	1.05	0.92
TM8X080C16MP11	CF/CM/CU42C	1.00	1.05	0.92
TM8X080C16MP11	CF/CM/CU42D	1.00	1.07	0.92
TM8X100C16MP11	CF/CM/CU24C	1.00	1.05	0.92
TM8X100C16MP11	CF/CM/CU30C	1.00	1.07	0.92
TM8X100C16MP11	CF/CM/CU30D	1.00	1.07	0.92
TM8X100C16MP11	CF/CM/CU36C	1.00	1.04	0.92
TM8X100C16MP11	CF/CM/CU36D	1.00	1.05	0.92
TM8X100C16MP11	CF/CM/CU42C	1.00	1.05	0.92
TM8X100C16MP11	CF/CM/CU42D	1.00	1.07	0.92
TM8Y060A12MP11	CF/CM/CU24A	1.00	1.08	0.94
TM8Y060A12MP11	CF/CM/CU30A	1.00	1.08	0.92
TM8Y060A12MP11	CF/CM36A	1.00	1.08	0.92
TM8Y080B12MP11	CF/CM/CU24B	1.00	1.09	0.94
TM8Y080B12MP11	CF/CM/CU30B	1.00	1.11	0.92
TM8Y080B12MP11	CF/CM/CU36B	1.00	1.08	0.92
TM8Y080B12MP11	CF42B	1.00	1.13	0.92
TM8Y080C16MP11	CF/CM/CU24C	1.00	1.05	0.92

FURNACE MULTIPLIERS- 2 TON (Continued)

Furnaces	Coil	T.C.	S.C.	KW
TM8Y080C16MP11	CF/CM/CU30C	1.00	1.07	0.92
TM8Y080C16MP11	CF/CM/CU30D	1.00	1.07	0.92
TM8Y080C16MP11	CF/CM/CU36C	1.00	1.04	0.92
TM8Y080C16MP11	CF/CM/CU36D	1.00	1.05	0.92
TM8Y080C16MP11	CF/CM/CU42C	1.00	1.05	0.92
TM8Y080C16MP11	CF/CM/CU42D	1.00	1.07	0.92
TM8Y100C16MP11	CF/CM/CU24C	1.00	1.05	0.92
TM8Y100C16MP11	CF/CM/CU30C	1.00	1.07	0.92
TM8Y100C16MP11	CF/CM/CU30D	1.00	1.07	0.92
TM8Y100C16MP11	CF/CM/CU36C	1.00	1.04	0.92
TM8Y100C16MP11	CF/CM/CU36D	1.00	1.05	0.92
TM8Y100C16MP11	CF/CM/CU42C	1.00	1.05	0.92
TM8Y100C16MP11	CF/CM/CU42D	1.00	1.07	0.92
TM9E040A10MP11	CF/CM/CU24A	1.00	1.09	0.98
TM9E040A10MP11	CF/CM/CU30A	0.99	1.05	0.97
TM9E040A10MP11	CF/CM36A	1.00	1.08	0.96
TM9E040A10MP12	CF/CM/CU24A	1.00	1.02	0.98
TM9E040A10MP12	CF/CM/CU24B	1.00	1.03	0.98
TM9E040A10MP12	CF/CM/CU30A	1.00	1.05	0.96
TM9E040A10MP12	CF/CM/CU30B	1.00	1.06	0.96
TM9E040A10MP12	CF/CM/CU36B	1.00	1.03	0.94
TM9E040A10MP12	CF/CM36A	1.00	1.03	0.94
TM9E040A10MP12	CF42B	1.00	1.04	0.96
TM9E060A10MP12	CF/CM/CU24A	1.00	1.03	0.96
TM9E060A10MP12	CF/CM/CU24B	1.00	1.05	0.96
TM9E060A10MP12	CF/CM/CU30A	1.00	1.06	0.94
TM9E060A10MP12	CF/CM/CU30B	1.00	1.07	0.94
TM9E060A10MP12	CF/CM/CU36B	1.00	1.04	0.92
TM9E060A10MP12	CF/CM36A	1.00	1.02	0.92
TM9E060A10MP12	CF42B	1.00	1.05	0.92
TM9E060B12MP11	CF/CM/CU24B	1.00	1.03	0.94
TM9E060B12MP11	CF/CM/CU30B	1.00	1.06	0.92
TM9E060B12MP11	CF/CM/CU36B	1.00	1.02	0.92
TM9E060B12MP11	CF/CM/CU36C	1.00	1.04	0.92
TM9E060B12MP11	CF/CM/CU42C	1.00	1.05	0.92
TM9E060B12MP11	CF/CM24C	1.00	1.03	0.94
TM9E060B12MP11	CF/CM30C	1.00	1.06	0.92
TM9E060B12MP11	CF42B	1.00	1.03	0.92
TM9E060B12MP12	CF/CM/CU24B	1.00	1.07	0.96
TM9E060B12MP12	CF/CM/CU30B	1.00	1.08	0.92
TM9E060B12MP12	CF/CM/CU36B	1.00	1.07	0.92
TM9E060B12MP12	CF/CM/CU36C	1.00	1.07	0.92
TM9E060B12MP12	CF/CM/CU42C	1.00	1.07	0.92
TM9E060B12MP12	CF/CM24C	1.00	1.07	0.96
TM9E060B12MP12	CF/CM30C	1.00	1.08	0.94
TM9E060B12MP12	CF42B	1.00	1.07	0.92
TM9E080B12MP11	CF/CM/CU24B	1.00	1.05	0.94
TM9E080B12MP11	CF/CM/CU30B	1.00	1.07	0.92
TM9E080B12MP11	CF/CM/CU36B	1.00	1.04	0.92
TM9E080B12MP11	CF42B	1.00	1.14	0.92
TM9E080B12MP12	CF/CM/CU24B	1.00	1.10	0.94
TM9E080B12MP12	CF/CM/CU30B	1.00	1.11	0.92
TM9E080B12MP12	CF/CM/CU36B	1.00	1.10	0.92
TM9E080B12MP12	CF/CM/CU36C	1.00	1.11	0.92
TM9E080B12MP12	CF/CM/CU42C	1.00	1.13	0.92

FURNACE MULTIPLIERS- 2 TON (Continued)

Furnaces	Coil	T.C.	S.C.	KW
TM9E080B12MP12	CF/CM24C	1.00	1.10	0.94
TM9E080B12MP12	CF/CM30C	1.00	1.11	0.92
TM9E080B12MP12	CF42B	1.00	1.08	0.92
TM9E080C16MP11	CF/CM/CU36C	1.00	0.98	0.92
TM9E080C16MP11	CF/CM/CU42C	1.00	0.99	0.92
TM9E080C16MP11	CF/CM24C	1.00	0.99	0.92
TM9E080C16MP11	CF/CM30C	1.00	1.00	0.92
TM9E080C16MP11	CF/CM36D	1.00	0.98	0.92
TM9E080C16MP11	CF/CM42D	1.00	0.99	0.92
TM9E080C16MP12	CF/CM/CU36C	1.00	1.07	0.92
TM9E080C16MP12	CF/CM/CU42C	1.00	1.08	0.92
TM9E080C16MP12	CF/CM24C	1.00	1.07	0.92
TM9E080C16MP12	CF/CM30C	1.00	1.16	0.92
TM9E080C16MP12	CF/CM36D	1.00	1.07	0.92
TM9E080C16MP12	CF/CM42D	1.00	1.18	0.92
TM9E100C16MP11	CF/CM/CU30D	0.99	1.04	0.91
TM9E100C16MP11	CF/CM/CU36C	1.00	1.01	0.92
TM9E100C16MP11	CF/CM/CU36D	1.00	1.01	0.92
TM9E100C16MP11	CF/CM/CU42C	1.00	1.02	0.92
TM9E100C16MP11	CF/CM/CU42D	1.00	1.02	0.92
TM9E100C16MP12	CF/CM/CU36C	1.00	1.10	0.92
TM9E100C16MP12	CF/CM/CU42C	1.00	1.11	0.92
TM9E100C16MP12	CF/CM24C	1.00	1.09	0.92
TM9E100C16MP12	CF/CM30C	1.00	1.11	0.92
TM9E100C16MP12	CF/CM36D	1.00	1.10	0.92
TM9E100C16MP12	CF/CM42D	1.00	1.11	0.92
TM9V040A10MP11C	CF/CM/CU24A	1.00	1.01	0.96
TM9V040A10MP11C	CF/CM/CU24B	1.00	1.00	0.96
TM9V040A10MP11C	CF/CM/CU30A	1.00	1.01	0.94
TM9V040A10MP11C	CF/CM/CU30B	1.00	1.01	0.94
TM9V040A10MP11C	CF/CM/CU36B	1.00	1.05	0.92
TM9V040A10MP11C	CF/CM36A	1.00	1.00	0.94
TM9V040A10MP11C	CF42B	1.00	1.07	0.92
TM9V040A10MP12C	CF/CM/CU24A	1.00	1.01	0.96
TM9V040A10MP12C	CF/CM/CU24B	1.00	1.00	0.96
TM9V040A10MP12C	CF/CM/CU30A	1.00	1.01	0.94
TM9V040A10MP12C	CF/CM/CU30B	1.00	1.01	0.94
TM9V040A10MP12C	CF/CM/CU36B	1.00	1.05	0.92
TM9V040A10MP12C	CF/CM36A	1.00	1.00	0.94
TM9V040A10MP12C	CF42B	1.00	1.07	0.92
TM9V060B12MP11C	CF/CM/CU24B	1.00	0.99	0.94
TM9V060B12MP11C	CF/CM/CU30B	1.00	1.07	0.92
TM9V060B12MP11C	CF/CM/CU36B	1.00	1.04	0.90
TM9V060B12MP11C	CF/CM/CU36C	1.00	1.04	0.90
TM9V060B12MP11C	CF/CM/CU42C	1.00	1.05	0.90
TM9V060B12MP11C	CF/CM24C	1.00	1.05	0.92
TM9V060B12MP11C	CF/CM30C	1.00	1.07	0.90
TM9V060B12MP11C	CF42B	1.00	1.05	0.90
TM9V060B12MP12C	CF/CM/CU24B	1.00	0.99	0.94
TM9V060B12MP12C	CF/CM/CU30B	1.00	1.07	0.92
TM9V060B12MP12C	CF/CM/CU36B	1.00	1.04	0.90
TM9V060B12MP12C	CF/CM/CU36C	1.00	1.04	0.90
TM9V060B12MP12C	CF/CM/CU42C	1.00	1.05	0.90
TM9V060B12MP12C	CF/CM24C	1.00	1.05	0.92
TM9V060B12MP12C	CF/CM30C	1.00	1.07	0.90

FURNACE MULTIPLIERS- 2 TON (Continued)

Furnaces	Coil	T.C.	S.C.	KW
TM9V060B12MP12C	CF42B	1.00	1.05	0.90
TM9V080B12MP12C	CF/CM/CU24B	1.00	1.10	0.92
TM9V080B12MP12C	CF/CM/CU30B	1.00	1.11	0.92
TM9V080B12MP12C	CF/CM/CU36B	1.00	1.10	0.92
TM9V080B12MP12C	CF42B	1.00	1.11	0.92
TM9V080C16MP11C	CF/CM/CU36C	1.00	1.19	0.92
TM9V080C16MP11C	CF/CM/CU42C	1.00	1.17	0.92
TM9V080C16MP11C	CF/CM24C	1.00	1.14	0.98
TM9V080C16MP11C	CF/CM30C	1.00	1.18	0.92
TM9V080C16MP11C	CF/CM36D	1.00	1.19	0.92
TM9V080C16MP11C	CF/CM42D	1.00	1.17	0.92
TM9V080C16MP12C	CF/CM/CU36C	1.00	1.19	0.92
TM9V080C16MP12C	CF/CM/CU42C	1.00	1.17	0.92
TM9V080C16MP12C	CF/CM24C	1.00	1.14	0.98
TM9V080C16MP12C	CF/CM30C	1.00	1.18	0.92
TM9V080C16MP12C	CF/CM36D	1.00	1.19	0.92
TM9V080C16MP12C	CF/CM42D	1.00	1.17	0.92
TM9Y040A10MP11	CF/CM/CU24A	1.00	1.09	0.98
TM9Y040A10MP11	CF/CM/CU30A	0.99	1.05	0.97
TM9Y040A10MP11	CF/CM36A	1.00	1.08	0.96
TM9Y060B12MP11	CF/CM/CU24B	1.00	1.03	0.94
TM9Y060B12MP11	CF/CM/CU30B	1.00	1.06	0.92
TM9Y060B12MP11	CF/CM/CU36B	1.00	1.02	0.92
TM9Y060B12MP11	CF/CM/CU36C	1.00	1.04	0.92
TM9Y060B12MP11	CF/CM/CU42C	1.00	1.05	0.92
TM9Y060B12MP11	CF/CM24C	1.00	1.03	0.94
TM9Y060B12MP11	CF/CM30C	1.00	1.06	0.92
TM9Y060B12MP11	CF42B	1.00	1.03	0.92
TM9Y080B12MP11	CF/CM/CU24B	1.00	1.05	0.94
TM9Y080B12MP11	CF/CM/CU30B	1.00	1.07	0.92
TM9Y080B12MP11	CF/CM/CU36B	1.00	1.04	0.92
TM9Y080B12MP11	CF42B	1.00	1.14	0.92
TM9Y080C16MP11	CF/CM/CU36C	1.00	0.98	0.92
TM9Y080C16MP11	CF/CM/CU42C	1.00	0.99	0.92
TM9Y080C16MP11	CF/CM24C	1.00	0.99	0.92
TM9Y080C16MP11	CF/CM30C	1.00	1.00	0.92
TM9Y080C16MP11	CF/CM36D	1.00	0.98	0.92
TM9Y080C16MP11	CF/CM42D	1.00	0.99	0.92
TM9Y100C16MP11	CF/CM/CU30D	0.99	1.04	0.91
TM9Y100C16MP11	CF/CM/CU36C	1.00	1.01	0.92
TM9Y100C16MP11	CF/CM/CU36D	1.00	1.01	0.92
TM9Y100C16MP11	CF/CM/CU42C	1.00	1.02	0.92
TM9Y100C16MP11	CF/CM/CU42D	1.00	1.02	0.92
TMLV060A12MP12C	CF/CM/CU24A	1.00	1.10	0.98
TMLV060A12MP12C	CF/CM/CU30A	1.00	1.11	0.96
TMLV060A12MP12C	CF/CM36A	1.00	1.10	0.92
TMLV080B12MP12C	CF/CM/CU24B	1.00	1.12	0.96
TMLV080B12MP12C	CF/CM/CU30B	1.00	1.11	0.94
TMLV080B12MP12C	CF/CM/CU36B	1.00	1.11	0.94
TMLV080B12MP12C	CF42B	1.00	1.13	0.92
TMLV080C16MP12C	CF/CM/CU30C	1.00	1.15	0.92
TMLV080C16MP12C	CF/CM/CU30D	1.00	1.15	0.92
TMLV080C16MP12C	CF/CM/CU36C	1.00	1.14	0.92
TMLV080C16MP12C	CF/CM/CU36D	1.00	1.14	0.92
TMLV080C16MP12C	CF/CM/CU42C	1.00	1.14	0.92

FURNACE MULTIPLIERS- 2 TON (Continued)

Furnaces	Coil	T.C.	S.C.	KW
TMLV080C16MP12C	CF/CM/CU42D	1.00	1.14	0.92
TMLV100C16MP12C	CF/CM/CU30C	1.00	1.15	0.92
TMLV100C16MP12C	CF/CM/CU30D	1.00	1.15	0.92
TMLV100C16MP12C	CF/CM/CU36C	1.00	1.14	0.92
TMLV100C16MP12C	CF/CM/CU36D	1.00	1.14	0.92
TMLV100C16MP12C	CF/CM/CU42C	1.00	1.14	0.92
TMLV100C16MP12C	CF/CM/CU42D	1.00	1.14	0.92
TMLX060A12MP11	CF/CM/CU24A	1.00	1.08	0.94
TMLX060A12MP11	CF/CM/CU30A	1.00	1.08	0.92
TMLX060A12MP11	CF/CM36A	1.00	1.08	0.92
TMLX080B12MP11	CF/CM/CU24B	1.00	1.09	0.94
TMLX080B12MP11	CF/CM/CU30B	1.00	1.11	0.92
TMLX080B12MP11	CF/CM/CU36B	1.00	1.08	0.92
TMLX080B12MP11	CF42B	1.00	1.13	0.92
TMLX080C16MP11	CF/CM/CU24C	1.00	1.05	0.92
TMLX080C16MP11	CF/CM/CU30C	1.00	1.07	0.92
TMLX080C16MP11	CF/CM/CU30D	1.00	1.07	0.92
TMLX080C16MP11	CF/CM/CU36C	1.00	1.04	0.92
TMLX080C16MP11	CF/CM/CU36D	1.00	1.05	0.92
TMLX080C16MP11	CF/CM/CU42C	1.00	1.05	0.92
TMLX080C16MP11	CF/CM/CU42D	1.00	1.07	0.92
TMLX100C16MP11	CF/CM/CU24C	1.00	1.05	0.92
TMLX100C16MP11	CF/CM/CU30C	1.00	1.07	0.92
TMLX100C16MP11	CF/CM/CU30D	1.00	1.07	0.92
TMLX100C16MP11	CF/CM/CU36C	1.00	1.04	0.92
TMLX100C16MP11	CF/CM/CU36D	1.00	1.05	0.92
TMLX100C16MP11	CF/CM/CU42C	1.00	1.05	0.92
TMLX100C16MP11	CF/CM/CU42D	1.00	1.07	0.92
TP9C060B12MP13C	CF/CM/CU24B	1.00	0.99	0.94
TP9C060B12MP13C	CF/CM/CU30B	1.00	1.07	0.92
TP9C060B12MP13C	CF/CM/CU36B	1.00	1.04	0.90
TP9C060B12MP13C	CF/CM/CU36C	1.00	1.04	0.90
TP9C060B12MP13C	CF/CM/CU42C	1.00	1.05	0.90
TP9C060B12MP13C	CF/CM24C	1.00	1.05	0.92
TP9C060B12MP13C	CF/CM30C	1.00	1.07	0.90
TP9C060B12MP13C	CF42B	1.00	1.05	0.90
TP9C080B12MP13C	CF/CM/CU24B	1.00	1.10	0.92
TP9C080B12MP13C	CF/CM/CU30B	1.00	1.11	0.92
TP9C080B12MP13C	CF/CM/CU36B	1.00	1.10	0.92
TP9C080B12MP13C	CF42B	1.00	1.11	0.92
TP9C080C16MP13C	CF/CM/CU36C	1.00	1.19	0.92
TP9C080C16MP13C	CF/CM/CU42C	1.00	1.17	0.92
TP9C080C16MP13C	CF/CM24C	1.00	1.14	0.98
TP9C080C16MP13C	CF/CM30C	1.00	1.18	0.92
TP9C080C16MP13C	CF/CM36D	1.00	1.19	0.92
TP9C080C16MP13C	CF/CM42D	1.00	1.17	0.92
CPLC060A12MP13C	CF/CM/CU24A	1.00	1.10	0.98
CPLC060A12MP13C	CF/CM/CU30A	1.00	1.11	0.96
CPLC060A12MP13C	CF/CM36A	1.00	1.10	0.92
CPLC080B12MP13C	CF/CM/CU24B	1.00	1.12	0.96
CPLC080B12MP13C	CF/CM/CU30B	1.00	1.11	0.94
CPLC080B12MP13C	CF/CM/CU36B	1.00	1.11	0.94
CPLC080B12MP13C	CF42B	1.00	1.13	0.92
CPLC080C16MP13C	CF/CM/CU30C	1.00	1.15	0.92
CPLC080C16MP13C	CF/CM/CU30D	1.00	1.15	0.92
CPLC080C16MP13C	CF/CM/CU36C	1.00	1.14	0.92
CPLC080C16MP13C	CF/CM/CU36D	1.00	1.14	0.92
CPLC080C16MP13C	CF/CM/CU42C	1.00	1.14	0.92
CPLC080C16MP13C	CF/CM/CU42D	1.00	1.14	0.92
CPLC100C16MP13C	CF/CM/CU30C	1.00	1.15	0.92
CPLC100C16MP13C	CF/CM/CU30D	1.00	1.15	0.92
CPLC100C16MP13C	CF/CM/CU36C	1.00	1.14	0.92
CPLC100C16MP13C	CF/CM/CU36D	1.00	1.14	0.92
CPLC100C16MP13C	CF/CM/CU42C	1.00	1.14	0.92
CPLC100C16MP13C	CF/CM/CU42D	1.00	1.14	0.92

FURNACE MULTIPLIERS- 2 TON (Continued)

Furnaces	Coil	T.C.	S.C.	KW
TPLC080B12MP13C	CF42B	1.00	1.13	0.92
TPLC080C16MP13C	CF/CM/CU30C	1.00	1.15	0.92
TPLC080C16MP13C	CF/CM/CU30D	1.00	1.15	0.92
TPLC080C16MP13C	CF/CM/CU36C	1.00	1.14	0.92
TPLC080C16MP13C	CF/CM/CU36D	1.00	1.14	0.92
TPLC080C16MP13C	CF/CM/CU42C	1.00	1.14	0.92
TPLC080C16MP13C	CF/CM/CU42D	1.00	1.14	0.92
TPLC100C16MP13C	CF/CM/CU30C	1.00	1.15	0.92
TPLC100C16MP13C	CF/CM/CU30D	1.00	1.15	0.92
TPLC100C16MP13C	CF/CM/CU36C	1.00	1.14	0.92
TPLC100C16MP13C	CF/CM/CU36D	1.00	1.14	0.92
TPLC100C16MP13C	CF/CM/CU42C	1.00	1.14	0.92
TPLC100C16MP13C	CF/CM/CU42D	1.00	1.14	0.92
CP9C060B12MP13C	CF/CM/CU24B	1.00	0.99	0.94
CP9C060B12MP13C	CF/CM/CU30B	1.00	1.07	0.92
CP9C060B12MP13C	CF/CM/CU36B	1.00	1.04	0.90
CP9C060B12MP13C	CF/CM/CU36C	1.00	1.04	0.90
CP9C060B12MP13C	CF/CM/CU42C	1.00	1.05	0.90
CP9C060B12MP13C	CF/CM24C	1.00	1.05	0.92
CP9C060B12MP13C	CF/CM30C	1.00	1.07	0.90
CP9C060B12MP13C	CF42B	1.00	1.05	0.90
CP9C080B12MP13C	CF/CM/CU24B	1.00	1.10	0.92
CP9C080B12MP13C	CF/CM/CU30B	1.00	1.11	0.92
CP9C080B12MP13C	CF/CM/CU36B	1.00	1.10	0.92
CP9C080B12MP13C	CF42B	1.00	1.11	0.92
CP9C080C16MP13C	CF/CM/CU36C	1.00	1.19	0.92
CP9C080C16MP13C	CF/CM/CU42C	1.00	1.17	0.92
CP9C080C16MP13C	CF/CM24C	1.00	1.14	0.98
CP9C080C16MP13C	CF/CM30C	1.00	1.18	0.92
CP9C080C16MP13C	CF/CM36D	1.00	1.19	0.92
CP9C080C16MP13C	CF/CM42D	1.00	1.17	0.92
CPLC060A12MP13C	CF/CM/CU24A	1.00	1.10	0.98
CPLC060A12MP13C	CF/CM/CU30A	1.00	1.11	0.96
CPLC060A12MP13C	CF/CM36A	1.00	1.10	0.92
CPLC080B12MP13C	CF/CM/CU24B	1.00	1.12	0.96
CPLC080B12MP13C	CF/CM/CU30B	1.00	1.11	0.94
CPLC080B12MP13C	CF/CM/CU36B	1.00	1.11	0.94
CPLC080B12MP13C	CF42B	1.00	1.13	0.92
CPLC080C16MP13C	CF/CM/CU30C	1.00	1.15	0.92
CPLC080C16MP13C	CF/CM/CU30D	1.00	1.15	0.92
CPLC080C16MP13C	CF/CM/CU36C	1.00	1.14	0.92
CPLC080C16MP13C	CF/CM/CU36D	1.00	1.14	0.92
CPLC080C16MP13C	CF/CM/CU42C	1.00	1.14	0.92
CPLC080C16MP13C	CF/CM/CU42D	1.00	1.14	0.92
CPLC100C16MP13C	CF/CM/CU30C	1.00	1.15	0.92
CPLC100C16MP13C	CF/CM/CU30D	1.00	1.15	0.92
CPLC100C16MP13C	CF/CM/CU36C	1.00	1.14	0.92
CPLC100C16MP13C	CF/CM/CU36D	1.00	1.14	0.92
CPLC100C16MP13C	CF/CM/CU42C	1.00	1.14	0.92
CPLC100C16MP13C	CF/CM/CU42D	1.00	1.14	0.92

PERFORMANCE DATA - 2.5 TON

CONDENSER-ONLY DATA (OUTDOOR UNIT)																		
MODEL	SATURATED SUCTION @ COMPRESSOR		Outdoor Ambient Temperature															
			55 °F		65 °F		75 °F		85 °F		95 °F		105 °F		115 °F		125 °F	
	T (°F)	P (PSIG)	MBH	KW	MBH	KW	MBH	KW	MBH	KW	MBH	KW	MBH	KW	MBH	KW	MBH	KW
TW4B3021S	35	107	26.5	1.33	25.2	1.50	23.8	1.69	22.5	1.89	21.1	2.12	19.6	2.38	18.1	2.69	16.5	3.04
	40	118	29.2	1.32	27.7	1.49	26.3	1.67	24.8	1.88	23.3	2.10	21.8	2.37	20.1	2.68	18.3	3.03
	45	130	32.1	1.31	30.5	1.48	29.0	1.66	27.4	1.86	25.7	2.09	24.0	2.35	22.2	2.67	20.3	3.01
	50	142	35.2	1.31	33.5	1.47	31.8	1.65	30.1	1.85	28.3	2.07	26.5	2.34	24.5	2.65	22.5	3.00
	55	156	38.5	1.30	36.7	1.46	34.9	1.64	33.0	1.83	31.1	2.05	29.1	2.32	27.0	2.63	24.8	2.98

Notes:

- For Outdoor Unit (Condenser) performance only. Data does not include the effects of air handler power or heat.
- Performance based on 15°F subcooling and 15°F superheat at the Outdoor Unit base valves.
 - Increase capacity by 1% for each 2°F increase in subcooling.
 - Decrease capacity by 1% for each 2°F decrease in subcooling.
- Maximum recommended condensing temperature is 140°F.

COOLING PERFORMANCE DATA																
OUTDOOR UNIT MODEL NO.		TW4B3021S														
INDOOR COIL MODEL NO.		CF30BXA1														
AIR TEMP. ENTERING OUTDOOR UNIT (°F)	ID CFM	800					1000					1200				
	ID DB (°F)	80	80	75	80	80	80	80	75	80	80	80	80	75	80	80
	ID WB (°F)	57	62	62	67	72	57	62	62	67	72	57	62	62	67	72
55	T.C.	27.0	29.0	29.1	30.9	32.5	28.1	29.3	29.4	31.2	32.5	29.1	29.7	29.7	31.5	32.5
	S.C.	26.8	23.6	20.4	19.5	15.5	27.8	25.0	21.4	20.2	15.7	28.7	26.3	22.3	20.9	16.0
	KW	1.56	1.56	1.56	1.57	1.58	1.63	1.64	1.63	1.64	1.65	1.70	1.71	1.71	1.71	1.73
65	T.C.	26.4	28.2	28.3	30.6	32.7	27.7	28.8	28.8	30.9	32.8	29.0	29.5	29.3	31.3	33.0
	S.C.	26.1	23.2	20.0	19.6	15.6	27.4	25.1	21.4	20.7	16.0	28.6	27.0	22.8	21.8	16.5
	KW	1.72	1.72	1.72	1.72	1.73	1.79	1.79	1.79	1.79	1.80	1.86	1.86	1.86	1.87	1.87
75	T.C.	25.7	27.3	27.4	30.3	32.9	27.3	28.3	28.2	30.7	33.2	28.9	29.3	28.9	31.1	33.5
	S.C.	25.4	22.9	19.6	19.7	15.7	26.9	25.3	21.5	21.2	16.3	28.4	27.6	23.4	22.7	17.0
	KW	1.88	1.88	1.88	1.88	1.88	1.95	1.95	1.95	1.95	1.95	2.02	2.02	2.02	2.02	2.02
85	T.C.	25.0	26.3	26.3	29.2	31.8	26.4	27.0	26.9	29.7	32.2	27.9	27.8	27.6	30.3	32.6
	S.C.	24.6	22.6	19.1	19.2	15.2	26.0	24.9	21.0	20.9	16.1	27.4	27.1	22.9	22.6	16.9
	KW	2.10	2.10	2.10	2.09	2.08	2.16	2.17	2.17	2.15	2.15	2.23	2.23	2.23	2.22	2.22
95	T.C.	24.2	25.3	25.2	28.1	30.8	25.6	25.8	25.7	28.8	31.2	26.9	26.2	26.2	29.5	31.7
	S.C.	23.8	22.4	18.5	18.6	14.8	25.1	24.5	20.5	20.6	15.8	26.4	26.2	22.5	22.6	16.8
	KW	2.31	2.32	2.32	2.30	2.28	2.37	2.38	2.38	2.36	2.35	2.43	2.44	2.44	2.42	2.42
105	T.C.	22.9	23.8	23.5	26.3	29.1	24.2	24.3	24.0	26.8	29.4	25.4	24.9	24.5	27.4	29.8
	S.C.	22.7	21.5	17.7	17.9	14.2	23.8	23.2	19.6	19.7	15.3	25.0	24.9	21.6	21.5	16.4
	KW	2.79	2.78	2.85	2.70	2.64	2.81	2.82	2.85	2.75	2.70	2.83	2.86	2.86	2.81	2.76
115	T.C.	21.7	22.2	21.8	24.5	27.4	22.9	22.9	22.3	24.9	27.7	24.0	23.5	22.8	25.4	28.0
	S.C.	21.6	20.7	16.8	17.3	13.7	22.6	22.0	18.8	18.9	14.8	23.6	23.4	20.7	20.5	15.9
	KW	3.26	3.23	3.36	3.08	2.98	3.23	3.25	3.31	3.14	3.04	3.21	3.26	3.26	3.19	3.10
125	T.C.	20.4	20.7	20.1	22.7	25.7	21.5	21.5	20.6	23.0	25.9	22.6	22.2	21.1	23.3	26.1
	S.C.	20.4	19.8	16.0	16.6	13.2	21.3	20.8	17.9	18.0	14.3	22.2	21.8	19.8	19.4	15.5
	KW	3.72	3.68	3.87	3.47	3.33	3.65	3.67	3.76	3.52	3.38	3.59	3.67	3.66	3.57	3.43

NOTE: ALL CAPACITIES INCLUDE INDOOR FAN HEAT. KW VALUES ARE FOR THE SYSTEM (OUTDOOR + INDOOR).

Green shaded cells are ACCA (TVA) conditions.

Blue shaded cells are AHRI conditions.

Multipliers for determining the performance with other indoor sections.

NOTE: For dry bulb temperatures different than those listed (between 73-87 °F), sensible capacity increases by 1060 BTUH per 1000 CFM per degree above the listed temperature and decreases by 1060 BTUH per 1000 CFM per degree below the listed temperature.

COIL MULTIPLIERS- 2.5 TON

Air Handler	Coil	T.C.	S.C.	KW
-	CF/CM/CU30B	1.00	1.00	1.00
-	CF/CM/CU30C	1.00	1.00	1.00
-	CF/CM/CU30D	1.00	1.00	1.00
-	CF/CM/CU36B	1.01	1.00	1.01
-	CF/CM/CU36C	1.01	1.00	1.01
-	CF/CM/CU36D	1.01	1.00	1.01
-	CF/CM/CU42C	1.01	1.00	1.01
-	CF/CM/CU42D	1.01	1.00	1.01
-	CF/CM36A	1.00	0.94	1.00
-	CF42B	1.01	1.00	1.01
AE30BX21	-	1.02	1.02	1.00
AE36BX21	-	1.03	1.03	0.99
AE36CX21	-	1.04	1.03	0.98
AP30BX21	-	1.02	1.00	1.02
AP36BX21	-	1.01	1.00	1.01
AP36CX21	-	1.01	1.00	1.01
AP42CX21	-	1.03	1.05	1.02
AVC30BX21	-	1.02	1.01	1.00
AVC36BX21	-	1.04	1.04	0.98
AVC36CX21	-	1.04	1.05	0.98
ME08BN21	CF/CM30B	1.01	0.99	0.97
ME08BN21	CF/CM36B	1.02	0.97	0.96
ME08BN21	CF42B	1.02	0.96	0.98
ME12BN21	CF/CM30B	0.99	0.92	0.95
ME12BN21	CF/CM36B	1.03	1.04	0.99
ME12BN21	CF42B	1.03	1.02	0.99
ME14DN21	CF/CM30D	1.04	1.06	0.98
ME14DN21	CF/CM36D	1.04	1.05	0.98
ME14DN21	CF/CM42D	1.04	1.02	0.98
ME16CN21	CF/CM30C	1.03	1.06	1.00
ME16CN21	CF/CM36C	1.04	1.07	1.02
ME16CN21	CF/CM42C	1.03	1.01	1.00
MVC08BN21	CF42B	1.01	0.93	0.96
MVC12BN21	CF/CM30B	0.99	0.92	0.97
MVC12BN21	CF/CM36B	1.03	1.02	1.00
MVC12BN21	CF42B	1.03	1.02	1.00
MVC14DN21	CF/CM30D	1.02	0.99	0.96
MVC14DN21	CF/CM36D	1.03	1.02	0.97
MVC14DN21	CF/CM42D	1.04	1.02	0.98
MVC16CN21	CF/CM30C	1.01	0.99	0.95
MVC16CN21	CF/CM36C	1.04	1.05	0.98
MVC16CN21	CF/CM42C	1.03	0.98	0.96
MVC20DN21	CF/CM36D	1.04	1.08	0.98
MVC20DN21	CF/CM42D	1.04	1.07	1.00

FURNACE MULTIPLIERS- 2.5 TON

Furnaces	Coil	T.C.	S.C.	KW
TL8E060A12UH11	CF/CM/CU30B	1.00	1.05	0.98
TL8E060A12UH11	CF/CM/CU36B	1.01	1.06	0.98
TL8E060A12UH11	CF42B	1.01	1.05	0.98
TL8E080C16UH11	CF/CM/CU36C	1.03	1.14	0.98
TL8E080C16UH11	CF/CM/CU42C	1.03	1.12	0.98
TL8E080C16UH11	CF/CM30C	1.01	1.10	0.98
TL8E080C16UH11	CF/CM36D	1.03	1.14	1.00
TL8E080C16UH11	CF/CM42D	1.03	1.12	0.98
TL8E100C20UH11	CF/CM/CU36C	1.03	1.18	0.99
TL8E100C20UH11	CF/CM/CU42C	1.04	1.17	1.00
TL8E100C20UH11	CF/CM30C	1.03	1.17	0.98
TL8E100C20UH11	CF/CM36D	1.03	1.18	0.99
TL8E100C20UH11	CF/CM42D	1.04	1.17	1.00
TL9E060B12UH11	CF/CM/CU30B	1.00	1.05	0.98
TL9E060B12UH11	CF/CM/CU36B	1.01	1.06	0.98
TL9E060B12UH11	CF/CM/CU36C	1.01	1.07	0.98
TL9E060B12UH11	CF/CM/CU42C	1.01	1.07	0.99
TL9E060B12UH11	CF/CM30C	1.00	1.05	0.98
TL9E060B12UH11	CF42B	1.01	1.05	0.98
TL9E080C16UH11	CF/CM/CU36C	1.01	1.10	0.97
TL9E080C16UH11	CF/CM/CU42C	1.02	1.09	0.98
TL9E080C16UH11	CF/CM30C	1.01	1.09	0.99
TL9E080C16UH11	CF/CM36D	1.01	1.10	0.99
TL9E080C16UH11	CF/CM42D	1.02	1.09	1.00
TL9E100C20UH11	CF/CM/CU36C	1.03	1.19	1.00
TL9E100C20UH11	CF/CM/CU42C	1.04	1.22	1.00
TL9E100C20UH11	CF/CM30C	1.02	1.21	1.00
TL9E100C20UH11	CF/CM36D	1.03	1.20	1.00
TL9E100C20UH11	CF/CM42D	1.04	1.22	1.02
TM8E040A12MP11	CF/CM/CU30B	1.01	1.06	0.98
TM8E040A12MP11	CF/CM/CU36B	1.01	1.09	0.99
TM8E040A12MP11	CF42B	1.01	1.06	0.99
TM8E060A12MP11	CF/CM/CU30B	1.01	1.06	0.98
TM8E060A12MP11	CF/CM/CU36B	1.01	1.09	0.99
TM8E060A12MP11	CF42B	1.01	1.05	0.98
TM8E080B12MP11	CF/CM/CU30B	1.01	1.09	0.99
TM8E080B12MP11	CF/CM/CU36B	1.01	1.08	0.98
TM8E080B12MP11	CF/CM/CU36C	1.01	1.10	0.99
TM8E080B12MP11	CF/CM/CU42C	1.02	1.09	1.00
TM8E080B12MP11	CF/CM30C	1.01	1.09	0.99
TM8E080B12MP11	CF42B	1.01	1.07	0.99
TM8E080C16MP11	CF/CM/CU36C	1.03	1.14	0.98
TM8E080C16MP11	CF/CM/CU42C	1.03	1.12	0.98
TM8E080C16MP11	CF/CM30C	1.01	1.10	0.99
TM8E080C16MP11	CF/CM36D	1.03	1.14	1.00
TM8E080C16MP11	CF/CM42D	1.03	1.12	0.98
TM8E100B12MP11	CF/CM/CU30B	1.00	1.04	0.98
TM8E100B12MP11	CF/CM/CU36B	1.00	1.04	0.98
TM8E100B12MP11	CF/CM/CU36C	1.02	1.10	1.00
TM8E100B12MP11	CF/CM/CU42C	1.01	1.06	0.99
TM8E100B12MP11	CF/CM30C	1.00	1.04	0.98
TM8E100B12MP11	CF42B	1.01	1.07	0.99
TM8E100C16MP11	CF/CM/CU36C	1.02	1.10	0.98
TM8E100C16MP11	CF/CM/CU42C	1.03	1.11	0.98
TM8E100C16MP11	CF/CM30C	1.01	1.10	0.98
TM8E100C16MP11	CF/CM36D	1.03	1.14	0.98

FURNACE MULTIPLIERS- 2.5 TON (Continued)

Furnaces	Coil	T.C.	S.C.	KW
TM8E100C16MP11	CF/CM42D	1.03	1.14	0.99
TM8E120C16MP11	CF/CM/CU36C	1.03	1.14	0.98
TM8E120C16MP11	CF/CM/CU42C	1.03	1.13	0.98
TM8E120C16MP11	CF/CM30C	1.01	1.10	0.99
TM8E120C16MP11	CF/CM36D	1.03	1.14	0.98
TM8E120C16MP11	CF/CM42D	1.03	1.14	0.99
TM8V060A12MP12C	CF/CM/CU30A	0.97	1.02	0.97
TM8V060A12MP12C	CF/CM36A	0.99	1.05	0.96
TM8V080B12MP12C	CF/CM/CU30B	0.99	1.06	0.98
TM8V080B12MP12C	CF/CM/CU36B	0.99	1.07	0.96
TM8V080B12MP12C	CF42B	0.99	1.06	0.97
TM8V080C16MP12C	CF/CM/CU30C	1.01	1.10	0.98
TM8V080C16MP12C	CF/CM/CU30D	1.01	1.10	0.94
TM8V080C16MP12C	CF/CM/CU36C	1.01	1.12	0.97
TM8V080C16MP12C	CF/CM/CU36D	1.01	1.12	0.95
TM8V080C16MP12C	CF/CM/CU42C	1.02	1.12	0.98
TM8V080C16MP12C	CF/CM/CU42D	1.02	1.12	0.94
TM8V100C16MP12C	CF/CM/CU30C	1.01	1.10	0.98
TM8V100C16MP12C	CF/CM/CU30D	1.01	1.10	0.94
TM8V100C16MP12C	CF/CM/CU36C	1.01	1.12	0.97
TM8V100C16MP12C	CF/CM/CU36D	1.01	1.12	0.95
TM8V100C16MP12C	CF/CM/CU42C	1.02	1.12	0.98
TM8V100C16MP12C	CF/CM/CU42D	1.02	1.12	0.94
TM8X060A12MP11	CF/CM/CU30A	0.97	1.02	0.95
TM8X060A12MP11	CF/CM36A	0.98	1.04	0.96
TM8X080B12MP11	CF/CM/CU30B	1.02	1.14	1.00
TM8X080B12MP11	CF/CM/CU36B	1.03	1.11	1.00
TM8X080B12MP11	CF42B	1.01	1.11	0.99
TM8X080C16MP11	CF/CM/CU30C	1.01	1.10	0.96
TM8X080C16MP11	CF/CM/CU30D	1.02	1.14	0.98
TM8X080C16MP11	CF/CM/CU36C	1.01	1.12	0.97
TM8X080C16MP11	CF/CM/CU36D	1.03	1.11	0.97
TM8X080C16MP11	CF/CM/CU42C	1.02	1.12	0.98
TM8X080C16MP11	CF/CM/CU42D	1.03	1.14	0.97
TM8X100C16MP11	CF/CM/CU30C	1.01	1.10	0.96
TM8X100C16MP11	CF/CM/CU30D	1.02	1.14	0.98
TM8X100C16MP11	CF/CM/CU36C	1.01	1.12	0.97
TM8X100C16MP11	CF/CM/CU36D	1.03	1.11	0.97
TM8X100C16MP11	CF/CM/CU42C	1.02	1.12	0.98
TM8X100C16MP11	CF/CM/CU42D	1.03	1.14	0.97
TM8X100C20MP11	CF/CM/CU30C	1.03	1.15	0.98
TM8X100C20MP11	CF/CM/CU30D	1.03	1.15	0.98
TM8X100C20MP11	CF/CM/CU36C	1.03	1.17	0.96
TM8X100C20MP11	CF/CM/CU36D	1.03	1.17	0.97
TM8X100C20MP11	CF/CM/CU42C	1.04	1.16	0.98
TM8X100C20MP11	CF/CM/CU42D	1.04	1.16	0.98
TM8X120C20MP11	CF/CM/CU30C	1.03	1.15	0.98
TM8X120C20MP11	CF/CM/CU30D	1.03	1.15	0.98
TM8X120C20MP11	CF/CM/CU36C	1.03	1.17	0.96
TM8X120C20MP11	CF/CM/CU36D	1.03	1.17	0.97
TM8X120C20MP11	CF/CM/CU42C	1.04	1.16	0.98
TM8X120C20MP11	CF/CM/CU42D	1.04	1.16	0.98
TM8Y060A12MP11	CF/CM/CU30A	0.97	1.02	0.95
TM8Y060A12MP11	CF/CM36A	0.98	1.04	0.96
TM8Y080B12MP11	CF/CM/CU30B	1.02	1.14	1.00
TM8Y080B12MP11	CF/CM/CU36B	1.03	1.11	1.00

FURNACE MULTIPLIERS- 2.5 TON (Continued)

Furnaces	Coil	T.C.	S.C.	KW
TM8Y080B12MP11	CF42B	1.01	1.11	0.99
TM8Y080C16MP11	CF/CM/CU30C	1.01	1.10	0.96
TM8Y080C16MP11	CF/CM/CU30D	1.02	1.14	0.98
TM8Y080C16MP11	CF/CM/CU36C	1.01	1.12	0.97
TM8Y080C16MP11	CF/CM/CU36D	1.03	1.11	0.97
TM8Y080C16MP11	CF/CM/CU42C	1.02	1.12	0.98
TM8Y080C16MP11	CF/CM/CU42D	1.03	1.14	0.97
TM8Y100C16MP11	CF/CM/CU30C	1.01	1.10	0.96
TM8Y100C16MP11	CF/CM/CU30D	1.02	1.14	0.98
TM8Y100C16MP11	CF/CM/CU36C	1.01	1.12	0.97
TM8Y100C16MP11	CF/CM/CU36D	1.03	1.11	0.97
TM8Y100C16MP11	CF/CM/CU42C	1.02	1.12	0.98
TM8Y100C16MP11	CF/CM/CU42D	1.03	1.14	0.97
TM8Y100C20MP11	CF/CM/CU30C	1.03	1.15	0.98
TM8Y100C20MP11	CF/CM/CU30D	1.03	1.15	0.98
TM8Y100C20MP11	CF/CM/CU36C	1.03	1.17	0.96
TM8Y100C20MP11	CF/CM/CU36D	1.03	1.17	0.97
TM8Y100C20MP11	CF/CM/CU42C	1.04	1.16	0.98
TM8Y100C20MP11	CF/CM/CU42D	1.04	1.16	0.98
TM8Y120C20MP11	CF/CM/CU30C	1.03	1.15	0.98
TM8Y120C20MP11	CF/CM/CU30D	1.03	1.15	0.98
TM8Y120C20MP11	CF/CM/CU36C	1.03	1.17	0.96
TM8Y120C20MP11	CF/CM/CU36D	1.03	1.17	0.97
TM8Y120C20MP11	CF/CM/CU42C	1.04	1.16	0.98
TM8Y120C20MP11	CF/CM/CU42D	1.04	1.16	0.98
TM9E040A10MP12	CF/CM/CU30B	0.99	1.05	0.99
TM9E040A10MP12	CF/CM/CU36B	1.00	1.06	1.00
TM9E040A10MP12	CF42B	1.00	1.05	1.00
TM9E060A10MP12	CF/CM/CU30B	0.99	1.03	0.97
TM9E060A10MP12	CF/CM/CU36B	0.99	1.04	0.97
TM9E060A10MP12	CF42B	1.01	1.04	0.98
TM9E060B12MP11	CF/CM/CU30B	1.00	1.05	0.98
TM9E060B12MP11	CF/CM/CU36B	1.00	1.05	0.98
TM9E060B12MP11	CF/CM/CU36C	1.01	1.07	0.98
TM9E060B12MP11	CF/CM/CU42C	1.01	1.07	0.99
TM9E060B12MP11	CF/CM30C	1.00	1.05	0.98
TM9E060B12MP11	CF42B	1.01	1.05	0.98
TM9E060B12MP12	CF/CM/CU30B	1.00	1.09	0.98
TM9E060B12MP12	CF/CM/CU36B	1.01	1.10	0.99
TM9E060B12MP12	CF/CM/CU36C	1.01	1.12	0.99
TM9E060B12MP12	CF/CM/CU42C	1.02	1.12	1.00
TM9E060B12MP12	CF/CM30C	1.01	1.10	1.00
TM9E060B12MP12	CF42B	1.01	1.09	0.99
TM9E080B12MP11	CF/CM/CU30B	1.01	1.13	0.99
TM9E080B12MP11	CF/CM/CU36B	1.03	1.11	0.98
TM9E080B12MP11	CF42B	1.03	1.13	0.98
TM9E080B12MP12	CF/CM/CU30B	1.01	1.11	0.98
TM9E080B12MP12	CF/CM/CU36B	1.01	1.10	0.99
TM9E080B12MP12	CF/CM/CU36C	1.02	1.13	1.00
TM9E080B12MP12	CF/CM/CU42C	1.03	1.12	1.00
TM9E080B12MP12	CF/CM30C	1.01	1.11	0.99
TM9E080B12MP12	CF42B	1.02	1.10	1.00
TM9E080C16MP11	CF/CM/CU36C	1.03	1.12	0.99
TM9E080C16MP11	CF/CM/CU42C	1.03	1.14	0.99
TM9E080C16MP11	CF/CM30C	1.02	1.14	0.98
TM9E080C16MP11	CF/CM36D	1.03	1.12	0.99

FURNACE MULTIPLIERS- 2.5 TON (Continued)

Furnaces	Coil	T.C.	S.C.	KW
TM9E080C16MP11	CF/CM42D	1.03	1.14	0.99
TM9E080C16MP12	CF/CM/CU36C	1.01	1.09	0.99
TM9E080C16MP12	CF/CM/CU42C	1.02	1.08	1.00
TM9E080C16MP12	CF/CM30C	1.01	1.06	0.98
TM9E080C16MP12	CF/CM36D	1.01	1.10	0.99
TM9E080C16MP12	CF/CM42D	1.02	1.09	1.00
TM9E100C16MP11	CF/CM/CU30C	1.02	1.14	0.98
TM9E100C16MP11	CF/CM/CU30D	1.03	1.15	0.98
TM9E100C16MP11	CF/CM/CU36C	1.03	1.12	0.99
TM9E100C16MP11	CF/CM/CU36D	1.03	1.17	0.95
TM9E100C16MP11	CF/CM/CU42C	1.03	1.14	0.99
TM9E100C16MP11	CF/CM/CU42D	1.04	1.16	0.96
TM9E100C16MP12	CF/CM/CU36C	1.02	1.10	0.98
TM9E100C16MP12	CF/CM/CU42C	1.03	1.11	0.98
TM9E100C16MP12	CF/CM30C	1.01	1.10	0.98
TM9E100C16MP12	CF/CM36D	1.02	1.13	1.00
TM9E100C16MP12	CF/CM42D	1.03	1.12	1.00
TM9E100C20MP12	CF/CM/CU36C	1.04	1.24	1.02
TM9E120D20MP11	CF/CM/CU30D	1.01	1.10	0.94
TM9E120D20MP11	CF/CM/CU36D	1.01	1.12	0.95
TM9E120D20MP11	CF/CM/CU42D	1.02	1.12	0.96
TM9V040A10MP11C	CF/CM/CU30B	0.99	1.00	0.98
TM9V040A10MP11C	CF/CM/CU36B	0.99	1.00	0.96
TM9V040A10MP11C	CF42B	0.99	1.00	0.97
TM9V040A10MP12C	CF/CM/CU30B	0.99	1.00	0.98
TM9V040A10MP12C	CF/CM/CU36B	0.99	1.00	0.96
TM9V040A10MP12C	CF42B	0.99	1.00	0.97
TM9V060B12MP11C	CF/CM/CU30B	0.99	1.00	0.96
TM9V060B12MP11C	CF/CM/CU36B	0.99	1.01	0.97
TM9V060B12MP11C	CF/CM/CU36C	0.99	1.01	0.97
TM9V060B12MP11C	CF/CM/CU42C	1.00	1.01	0.98
TM9V060B12MP11C	CF/CM30C	0.99	1.00	0.96
TM9V060B12MP11C	CF42B	0.99	1.00	0.97
TM9V060B12MP12C	CF/CM/CU30B	0.99	1.00	0.96
TM9V060B12MP12C	CF/CM/CU36B	0.99	1.01	0.97
TM9V060B12MP12C	CF/CM/CU36C	0.99	1.01	0.97
TM9V060B12MP12C	CF/CM/CU42C	1.00	1.01	0.98
TM9V060B12MP12C	CF/CM30C	0.99	1.00	0.96
TM9V060B12MP12C	CF42B	0.99	1.00	0.97
TM9V080B12MP12C	CF/CM/CU30B	1.01	1.13	0.99
TM9V080B12MP12C	CF/CM/CU36B	1.03	1.11	1.00
TM9V080B12MP12C	CF42B	1.03	1.13	1.00
TM9V080C16MP11C	CF/CM/CU36C	1.02	1.13	0.98
TM9V080C16MP11C	CF/CM/CU42C	1.03	1.12	0.98
TM9V080C16MP11C	CF/CM30C	1.01	1.11	0.97
TM9V080C16MP11C	CF/CM36D	1.02	1.13	0.98
TM9V080C16MP11C	CF/CM42D	1.03	1.12	0.98
TM9V080C16MP12C	CF/CM/CU36C	1.02	1.13	0.98
TM9V080C16MP12C	CF/CM/CU42C	1.03	1.12	0.98
TM9V080C16MP12C	CF/CM30C	1.01	1.11	0.97
TM9V080C16MP12C	CF/CM36D	1.02	1.13	0.98
TM9V080C16MP12C	CF/CM42D	1.03	1.12	0.98
TM9V100C16MP12C	CF/CM/CU30C	1.03	1.15	0.98
TM9V100C16MP12C	CF/CM/CU30D	1.02	1.14	0.94
TM9V100C16MP12C	CF/CM/CU36C	1.03	1.17	0.98
TM9V100C16MP12C	CF/CM/CU36D	1.03	1.11	0.95

FURNACE MULTIPLIERS- 2.5 TON (Continued)

Furnaces	Coil	T.C.	S.C.	KW
TM9V100C16MP12C	CF/CM/CU42C	1.04	1.16	1.00
TM9V100C16MP12C	CF/CM/CU42D	1.03	1.14	0.95
TM9V100C20MP12C	CF/CM/CU30D	1.03	1.20	0.98
TM9V100C20MP12C	CF/CM/CU36C	1.03	1.20	1.01
TM9V100C20MP12C	CF/CM/CU36D	1.03	1.20	0.97
TM9V100C20MP12C	CF/CM/CU42C	1.03	1.21	0.99
TM9V100C20MP12C	CF/CM/CU42D	1.03	1.21	0.97
TM9V120D20MP12C	CF/CM/CU36D	1.03	1.17	0.97
TM9V120D20MP12C	CF/CM/CU42D	1.04	1.17	1.00
TM9Y060B12MP11	CF/CM/CU30B	1.00	1.05	0.98
TM9Y060B12MP11	CF/CM/CU36B	1.00	1.05	0.98
TM9Y060B12MP11	CF/CM/CU36C	1.01	1.07	0.98
TM9Y060B12MP11	CF/CM/CU42C	1.01	1.07	0.99
TM9Y060B12MP11	CF/CM30C	1.00	1.05	0.98
TM9Y060B12MP11	CF42B	1.01	1.05	0.98
TM9Y080B12MP11	CF/CM/CU30B	1.01	1.13	0.99
TM9Y080B12MP11	CF/CM/CU36B	1.03	1.11	0.98
TM9Y080B12MP11	CF42B	1.03	1.13	0.98
TM9Y080C16MP11	CF/CM/CU36C	1.03	1.12	0.99
TM9Y080C16MP11	CF/CM/CU42C	1.03	1.14	0.99
TM9Y080C16MP11	CF/CM30C	1.02	1.14	0.98
TM9Y080C16MP11	CF/CM36D	1.03	1.12	0.99
TM9Y080C16MP11	CF/CM42D	1.03	1.14	0.99
TM9Y100C16MP11	CF/CM/CU30C	1.02	1.14	0.98
TM9Y100C16MP11	CF/CM/CU30D	1.03	1.15	0.98
TM9Y100C16MP11	CF/CM/CU36C	1.03	1.12	0.99
TM9Y100C16MP11	CF/CM/CU36D	1.03	1.17	0.95
TM9Y100C16MP11	CF/CM/CU42C	1.03	1.14	0.99
TM9Y100C16MP11	CF/CM/CU42D	1.04	1.16	0.96
TM9Y120D20MP11	CF/CM/CU30D	1.01	1.10	0.94
TM9Y120D20MP11	CF/CM/CU36D	1.01	1.12	0.95
TM9Y120D20MP11	CF/CM/CU42D	1.02	1.12	0.96
TMLV060A12MP12C	CF/CM/CU30A	0.97	1.02	0.97
TMLV060A12MP12C	CF/CM36A	0.99	1.05	0.96
TMLV080B12MP12C	CF/CM/CU30B	0.99	1.06	0.98
TMLV080B12MP12C	CF/CM/CU36B	0.99	1.07	0.96
TMLV080B12MP12C	CF42B	0.99	1.06	0.97
TMLV080C16MP12C	CF/CM/CU30C	1.01	1.10	0.98
TMLV080C16MP12C	CF/CM/CU30D	1.01	1.10	0.94
TMLV080C16MP12C	CF/CM/CU36C	1.01	1.12	0.97
TMLV080C16MP12C	CF/CM/CU36D	1.01	1.12	0.95
TMLV080C16MP12C	CF/CM/CU42C	1.02	1.12	0.98
TMLV080C16MP12C	CF/CM/CU42D	1.02	1.12	0.94
TMLV100C16MP12C	CF/CM/CU30C	1.01	1.10	0.98
TMLV100C16MP12C	CF/CM/CU30D	1.01	1.10	0.94
TMLV100C16MP12C	CF/CM/CU36C	1.01	1.12	0.97
TMLV100C16MP12C	CF/CM/CU36D	1.01	1.12	0.95
TMLV100C16MP12C	CF/CM/CU42C	1.02	1.12	0.98
TMLV100C16MP12C	CF/CM/CU42D	1.02	1.12	0.94
TMLX060A12MP11	CF/CM/CU30A	0.97	1.02	0.95
TMLX060A12MP11	CF/CM36A	0.98	1.04	0.96
TMLX080B12MP11	CF/CM/CU30B	1.02	1.14	1.00
TMLX080B12MP11	CF/CM/CU36B	1.03	1.11	1.00
TMLX080B12MP11	CF42B	1.01	1.11	0.99
TMLX080C16MP11	CF/CM/CU30C	1.01	1.10	0.96
TMLX080C16MP11	CF/CM/CU30D	1.02	1.14	0.98

FURNACE MULTIPLIERS- 2.5 TON (Continued)

Furnaces	Coil	T.C.	S.C.	KW
TMLX080C16MP11	CF/CM/CU36C	1.01	1.12	0.97
TMLX080C16MP11	CF/CM/CU36D	1.03	1.11	0.97
TMLX080C16MP11	CF/CM/CU42C	1.02	1.12	0.98
TMLX080C16MP11	CF/CM/CU42D	1.03	1.14	0.97
TMLX100C16MP11	CF/CM/CU30C	1.01	1.10	0.96
TMLX100C16MP11	CF/CM/CU30D	1.02	1.14	0.98
TMLX100C16MP11	CF/CM/CU36C	1.01	1.12	0.97
TMLX100C16MP11	CF/CM/CU36D	1.03	1.11	0.97
TMLX100C16MP11	CF/CM/CU42C	1.02	1.12	0.98
TMLX100C16MP11	CF/CM/CU42D	1.03	1.14	0.97
TMLX100C20MP11	CF/CM/CU30C	1.03	1.15	0.98
TMLX100C20MP11	CF/CM/CU30D	1.03	1.15	0.98
TMLX100C20MP11	CF/CM/CU36C	1.03	1.17	0.96
TMLX100C20MP11	CF/CM/CU36D	1.03	1.17	0.97
TMLX100C20MP11	CF/CM/CU42C	1.04	1.16	0.98
TMLX100C20MP11	CF/CM/CU42D	1.04	1.16	0.98
TMLX120C20MP11	CF/CM/CU30C	1.03	1.15	0.98
TMLX120C20MP11	CF/CM/CU30D	1.03	1.15	0.98
TMLX120C20MP11	CF/CM/CU36C	1.03	1.17	0.96
TMLX120C20MP11	CF/CM/CU36D	1.03	1.17	0.97
TMLX120C20MP11	CF/CM/CU42C	1.04	1.16	0.98
TMLX120C20MP11	CF/CM/CU42D	1.04	1.16	0.98
TP9C060B12MP13C	CF/CM/CU30B	0.99	1.00	0.96
TP9C060B12MP13C	CF/CM/CU36B	0.99	1.01	0.97
TP9C060B12MP13C	CF/CM/CU36C	0.99	1.01	0.97
TP9C060B12MP13C	CF/CM/CU42C	1.00	1.01	0.98
TP9C060B12MP13C	CF/CM30C	0.99	1.00	0.96
TP9C060B12MP13C	CF42B	0.99	1.00	0.97
TP9C080B12MP13C	CF/CM/CU30B	1.01	1.13	0.99
TP9C080B12MP13C	CF/CM/CU36B	1.03	1.11	1.00
TP9C080B12MP13C	CF42B	1.03	1.13	1.00
TP9C080C16MP13C	CF/CM/CU36C	1.02	1.13	0.98
TP9C080C16MP13C	CF/CM/CU42C	1.03	1.12	0.98
TP9C080C16MP13C	CF/CM30C	1.01	1.11	0.97
TP9C080C16MP13C	CF/CM36D	1.02	1.13	0.98
TP9C080C16MP13C	CF/CM42D	1.03	1.12	0.98
TP9C100C16MP13C	CF/CM/CU30C	1.03	1.15	0.98
TP9C100C16MP13C	CF/CM/CU30D	1.02	1.14	0.94
TP9C100C16MP13C	CF/CM/CU36C	1.03	1.17	0.98
TP9C100C16MP13C	CF/CM/CU36D	1.03	1.11	0.95
TP9C100C16MP13C	CF/CM/CU42C	1.04	1.16	1.00
TP9C100C16MP13C	CF/CM/CU42D	1.03	1.14	0.95
TP9C100C20MP13C	CF/CM/CU30D	1.03	1.20	0.98
TP9C100C20MP13C	CF/CM/CU36C	1.03	1.20	1.01
TP9C100C20MP13C	CF/CM/CU36D	1.03	1.20	0.97
TP9C100C20MP13C	CF/CM/CU42C	1.03	1.21	0.99
TP9C100C20MP13C	CF/CM/CU42D	1.03	1.21	0.97
TP9C120D20MP13C	CF/CM/CU36D	1.03	1.17	0.97
TP9C120D20MP13C	CF/CM/CU42D	1.04	1.17	1.00
TPLC060A12MP13C	CF/CM/CU30A	0.97	1.02	0.97
TPLC060A12MP13C	CF/CM36A	0.99	1.05	0.96
TPLC080B12MP13C	CF/CM/CU30B	0.99	1.06	0.98
TPLC080B12MP13C	CF/CM/CU36B	0.99	1.07	0.96
TPLC080B12MP13C	CF42B	0.99	1.06	0.97
TPLC080C16MP13C	CF/CM/CU30C	1.01	1.10	0.98
TPLC080C16MP13C	CF/CM/CU30D	1.01	1.10	0.94
TPLC080C16MP13C	CF/CM/CU36C	1.01	1.12	0.97
TPLC080C16MP13C	CF/CM/CU36D	1.01	1.12	0.95
TPLC080C16MP13C	CF/CM/CU42C	1.02	1.12	0.98
TPLC080C16MP13C	CF/CM/CU42D	1.02	1.12	0.94
TPLC100C16MP13C	CF/CM/CU30C	1.01	1.10	0.98
TPLC100C16MP13C	CF/CM/CU30D	1.01	1.10	0.94
TPLC100C16MP13C	CF/CM/CU36C	1.01	1.12	0.97
TPLC100C16MP13C	CF/CM/CU36D	1.01	1.12	0.95
TPLC100C16MP13C	CF/CM/CU42C	1.02	1.12	0.98
TPLC100C16MP13C	CF/CM/CU42D	1.02	1.12	0.94

FURNACE MULTIPLIERS- 2.5 TON (Continued)

Furnaces	Coil	T.C.	S.C.	KW
TPLC080C16MP13C	CF/CM/CU36C	1.01	1.12	0.97
TPLC080C16MP13C	CF/CM/CU36D	1.01	1.12	0.95
TPLC080C16MP13C	CF/CM/CU42C	1.02	1.12	0.98
TPLC080C16MP13C	CF/CM/CU42D	1.02	1.12	0.94
TPLC100C16MP13C	CF/CM/CU30C	1.01	1.10	0.98
TPLC100C16MP13C	CF/CM/CU30D	1.01	1.10	0.94
TPLC100C16MP13C	CF/CM/CU36C	1.01	1.12	0.97
TPLC100C16MP13C	CF/CM/CU36D	1.01	1.12	0.95
TPLC100C16MP13C	CF/CM/CU42C	1.02	1.12	0.98
TPLC100C16MP13C	CF/CM/CU42D	1.02	1.12	0.94
CP9C060B12MP13C	CF/CM/CU30B	0.99	1.00	0.96
CP9C060B12MP13C	CF/CM/CU36B	0.99	1.01	0.97
CP9C060B12MP13C	CF/CM/CU36C	0.99	1.01	0.97
CP9C060B12MP13C	CF/CM/CU42C	1.00	1.01	0.98
CP9C060B12MP13C	CF/CM30C	0.99	1.00	0.96
CP9C060B12MP13C	CF42B	0.99	1.00	0.97
CP9C080B12MP13C	CF/CM/CU30B	1.01	1.13	0.99
CP9C080B12MP13C	CF/CM/CU36B	1.03	1.11	1.00
CP9C080B12MP13C	CF42B	1.03	1.13	1.00
CP9C080C16MP13C	CF/CM/CU36C	1.02	1.13	0.98
CP9C080C16MP13C	CF/CM/CU42C	1.03	1.12	0.98
CP9C080C16MP13C	CF/CM30C	1.01	1.11	0.97
CP9C080C16MP13C	CF/CM36D	1.02	1.13	0.98
CP9C080C16MP13C	CF/CM42D	1.03	1.12	0.98
CP9C100C16MP13C	CF/CM/CU30C	1.03	1.15	0.98
CP9C100C16MP13C	CF/CM/CU30D	1.02	1.14	0.94
CP9C100C16MP13C	CF/CM/CU36C	1.03	1.17	0.98
CP9C100C16MP13C	CF/CM/CU36D	1.03	1.11	0.95
CP9C100C16MP13C	CF/CM/CU42C	1.04	1.16	1.00
CP9C100C16MP13C	CF/CM/CU42D	1.03	1.14	0.95
CP9C100C20MP13C	CF/CM/CU30D	1.03	1.20	0.98
CP9C100C20MP13C	CF/CM/CU36C	1.03	1.20	1.01
CP9C100C20MP13C	CF/CM/CU36D	1.03	1.20	0.97
CP9C100C20MP13C	CF/CM/CU42C	1.03	1.21	0.99
CP9C100C20MP13C	CF/CM/CU42D	1.03	1.21	0.97
CP9C120D20MP13C	CF/CM/CU36D	1.03	1.17	0.97
CP9C120D20MP13C	CF/CM/CU42D	1.04	1.17	1.00
CPLC060A12MP13C	CF/CM/CU30A	0.97	1.02	0.97
CPLC060A12MP13C	CF/CM36A	0.99	1.05	0.96
CPLC080B12MP13C	CF/CM/CU30B	0.99	1.06	0.98
CPLC080B12MP13C	CF/CM/CU36B	0.99	1.07	0.96
CPLC080B12MP13C	CF42B	0.99	1.06	0.97
CPLC080C16MP13C	CF/CM/CU30C	1.01	1.10	0.98
CPLC080C16MP13C	CF/CM/CU30D	1.01	1.10	0.94
CPLC080C16MP13C	CF/CM/CU36C	1.01	1.12	0.97
CPLC080C16MP13C	CF/CM/CU36D	1.01	1.12	0.95
CPLC080C16MP13C	CF/CM/CU42C	1.02	1.12	0.98
CPLC080C16MP13C	CF/CM/CU42D	1.02	1.12	0.94
CPLC100C16MP13C	CF/CM/CU30C	1.01	1.10	0.98
CPLC100C16MP13C	CF/CM/CU30D	1.01	1.10	0.94
CPLC100C16MP13C	CF/CM/CU36C	1.01	1.12	0.97
CPLC100C16MP13C	CF/CM/CU36D	1.01	1.12	0.95
CPLC100C16MP13C	CF/CM/CU42C	1.02	1.12	0.98
CPLC100C16MP13C	CF/CM/CU42D	1.02	1.12	0.94

PERFORMANCE DATA - 3 TON

CONDENSER-ONLY DATA (OUTDOOR UNIT)																		
MODEL	SATURATED SUCTION @ COMPRESSOR		Outdoor Ambient Temperature															
			55 °F		65 °F		75 °F		85 °F		95 °F		105 °F		115 °F		125 °F	
	T (°F)	P (PSIG)	MBH	KW	MBH	KW	MBH	KW	MBH	KW	MBH	KW	MBH	KW	MBH	KW	MBH	KW
TW4B3621S	35	107	34.0	1.68	32.3	1.88	30.6	2.10	28.8	2.35	27.0	2.62	25.1	2.96	23.0	3.36	20.9	3.82
	40	118	37.4	1.67	35.6	1.87	33.8	2.09	31.9	2.33	29.9	2.61	27.8	2.94	25.6	3.34	23.3	3.79
	45	130	41.1	1.67	39.2	1.86	37.2	2.08	35.2	2.32	33.0	2.59	30.8	2.92	28.4	3.32	25.9	3.76
	50	142	45.1	1.67	43.0	1.86	40.9	2.07	38.7	2.31	36.4	2.57	33.9	2.90	31.4	3.29	28.7	3.73
	55	156	49.3	1.67	47.0	1.86	44.7	2.06	42.4	2.30	39.9	2.56	37.3	2.89	34.6	3.27	31.7	3.70

Notes:

- For Outdoor Unit (Condenser) performance only. Data does not include the effects of air handler power or heat.
- Performance based on 15°F subcooling and 15°F superheat at the Outdoor Unit base valves.
 - Increase capacity by 1% for each 2°F increase in subcooling.
 - Decrease capacity by 1% for each 2°F decrease in subcooling.
- Maximum recommended condensing temperature is 140°F.

COOLING PERFORMANCE DATA																
OUTDOOR UNIT MODEL NO.		TW4B3621S														
INDOOR COIL MODEL NO.		CF36BXA1														
AIR TEMP. ENTERING OUTDOOR UNIT (°F)	ID CFM	1000					1200					1400				
	ID DB (°F)	80	80	75	80	80	80	80	75	80	80	80	80	75	80	80
	ID WB (°F)	57	62	62	67	72	57	62	62	67	72	57	62	62	67	72
55	T.C.	34.1	37.4	37.7	39.0	40.2	32.6	38.1	38.4	39.7	40.3	31.0	38.9	39.1	40.5	40.4
	S.C.	34.1	30.8	26.3	24.8	19.1	32.6	32.9	28.0	25.9	19.5	31.0	35.0	29.8	27.1	20.0
	KW	1.89	1.89	1.89	1.89	1.91	1.96	1.96	1.96	1.97	1.98	2.03	2.03	2.03	2.04	2.05
65	T.C.	32.8	45.3	36.1	38.6	40.8	33.0	41.5	37.0	39.2	41.0	33.3	37.7	37.9	39.9	41.3
	S.C.	32.8	29.8	25.4	24.7	19.3	33.0	32.3	27.4	26.4	20.0	33.3	34.7	29.4	28.0	20.7
	KW	2.08	2.08	2.08	2.08	2.09	2.15	2.15	2.15	2.15	2.16	2.21	2.22	2.22	2.22	2.23
75	T.C.	31.6	53.1	34.6	38.2	41.4	33.5	44.8	35.6	38.8	41.7	35.5	36.6	36.7	39.3	42.1
	S.C.	31.6	28.8	24.6	24.7	19.5	33.5	31.6	26.8	26.8	20.5	35.5	34.5	29.1	28.9	21.5
	KW	2.28	2.28	2.28	2.27	2.27	2.34	2.34	2.34	2.33	2.34	2.40	2.40	2.41	2.40	2.41
85	T.C.	30.4	42.1	32.9	36.3	39.8	32.2	38.3	33.8	36.9	40.3	34.0	34.6	34.7	37.5	40.8
	S.C.	30.4	27.9	23.7	23.8	19.0	32.2	30.5	25.8	25.9	20.1	34.0	33.2	27.9	28.0	21.1
	KW	2.58	2.57	2.59	2.55	2.52	2.63	2.63	2.64	2.60	2.59	2.68	2.68	2.69	2.66	2.66
95	T.C.	29.3	31.0	31.3	34.3	38.2	30.8	31.8	32.0	35.0	38.9	32.4	32.6	32.7	35.7	39.5
	S.C.	29.3	27.1	22.8	22.9	18.4	30.8	29.5	24.7	25.0	19.6	32.4	31.9	26.7	27.1	20.8
	KW	2.88	2.86	2.90	2.82	2.78	2.92	2.91	2.94	2.87	2.85	2.95	2.96	2.97	2.91	2.92
105	T.C.	27.9	28.8	29.0	32.1	35.6	29.4	29.8	29.8	32.7	36.1	30.9	30.7	30.5	33.3	36.7
	S.C.	27.9	26.0	21.9	22.2	17.6	29.4	28.1	24.0	24.3	18.7	30.9	30.2	26.0	26.4	19.9
	KW	3.42	3.46	3.48	3.34	3.28	3.44	3.47	3.50	3.38	3.34	3.45	3.47	3.52	3.43	3.40
115	T.C.	26.5	26.7	26.8	30.1	33.1	28.0	27.8	27.6	30.5	33.5	29.4	28.9	28.5	31.0	34.0
	S.C.	26.5	25.0	21.1	21.5	16.7	28.0	26.8	23.2	23.6	17.8	29.4	28.7	25.4	25.7	18.9
	KW	3.94	4.05	4.05	3.84	3.77	3.94	4.00	4.05	3.89	3.82	3.94	3.95	4.04	3.93	3.87
125	T.C.	25.2	24.6	24.6	28.0	30.5	26.6	25.8	25.5	28.3	30.9	27.9	27.1	26.4	28.6	31.3
	S.C.	25.2	24.0	20.2	20.7	15.8	26.6	25.5	22.5	22.9	16.9	27.9	27.1	24.8	25.0	18.0
	KW	4.46	4.63	4.62	4.35	4.26	4.44	4.54	4.59	4.39	4.30	4.43	4.44	4.57	4.43	4.33

NOTE: ALL CAPACITIES INCLUDE INDOOR FAN HEAT. KW VALUES ARE FOR THE SYSTEM (OUTDOOR + INDOOR).

Green shaded cells are ACCA (TVA) conditions.

Blue shaded cells are AHRI conditions.

Multipliers for determining the performance with other indoor sections.

NOTE: For dry bulb temperatures different than those listed (between 73-87 °F), sensible capacity increases by 1060 BTUH per 1000 CFM per degree above the listed temperature and decreases by 1060 BTUH per 1000 CFM per degree below the listed temperature.

COIL MULTIPLIERS- 3 TON

Air Handler	Coil	T.C.	S.C.	KW
-	CF/CM/CU36B	1.00	1.00	1.00
-	CF/CM/CU36C	1.00	1.00	1.00
-	CF/CM/CU36D	1.00	1.00	1.00
-	CF/CM/CU42C	1.03	1.02	1.02
-	CF/CM/CU42D	1.03	1.02	1.02
-	CF/CM/CU48C	1.03	1.02	1.02
-	CF/CM/CU48D	1.03	1.02	1.02
-	CF42B	1.03	1.02	1.02
AE36BX21	-	1.03	0.96	1.00
AE36CX21	-	1.03	1.04	0.97
AE42CX21	-	1.03	1.02	0.98
AE48CX21	-	1.03	1.04	0.97
AE48DX21	-	1.03	1.03	0.97
AP36BX21	-	1.01	0.94	1.01
AP36CX21	-	1.03	1.03	1.02
AP42CX21	-	1.03	1.04	1.02
AP48CX21	-	1.03	1.02	1.02
AP48DX21	-	1.03	1.06	1.02
AVC36BX21	-	1.03	0.96	1.00
AVC36CX21	-	1.03	1.02	0.97
AVC42CX21	-	1.03	1.01	0.97
AVC48CX21	-	1.03	0.98	0.97
AVC48DX21	-	1.03	1.07	0.97
ME12BN21	CF/CM36B	1.03	0.96	1.00
ME12BN21	CF42B	1.03	0.96	1.00
ME14DN21	CF/CM36D	1.03	1.05	0.97
ME14DN21	CF/CM42D	1.03	1.04	0.97
ME14DN21	CF/CM48D	1.03	1.02	0.97
ME16CN21	CF/CM36C	1.03	1.04	0.97
ME16CN21	CF/CM42C	1.03	1.03	0.97
ME16CN21	CF/CM48C	1.03	1.03	0.97
ME20DN21	CF/CM36D	1.03	1.07	1.00
ME20DN21	CF/CM42D	1.03	1.07	1.00
ME20DN21	CF/CM48D	1.03	1.06	1.00
MVC08BN21	CF42B	1.03	0.96	1.00
MVC12BN21	CF/CM36B	1.03	0.96	1.00
MVC12BN21	CF42B	1.03	0.96	1.00
MVC14DN21	CF/CM36D	1.03	0.94	0.98
MVC14DN21	CF/CM42D	1.03	1.05	0.97
MVC14DN21	CF/CM48D	1.03	1.01	0.97
MVC16CN21	CF/CM36C	1.03	0.99	0.97
MVC16CN21	CF/CM42C	1.03	1.06	0.98
MVC16CN21	CF/CM48C	1.03	1.02	0.97
MVC20DN21	CF/CM36D	1.03	1.00	0.97
MVC20DN21	CF/CM42D	1.03	1.02	0.98
MVC20DN21	CF/CM48D	1.03	1.02	0.97

FURNACE MULTIPLIERS- 3 TON

Furnaces	Coil	T.C.	S.C.	KW
TL8E060A12UH11	CF/CM/CU36B	1.03	1.06	1.02
TL8E060A12UH11	CF42B	1.03	1.04	1.00
TL8E080C16UH11	CF/CM/CU36C	1.03	1.10	0.98
TL8E080C16UH11	CF/CM/CU42C	1.03	1.08	0.98
TL8E080C16UH11	CF/CM/CU48C	1.03	1.10	0.98
TL8E080C16UH11	CF/CM/CU48D	1.03	1.10	0.98
TL8E080C16UH11	CF/CM36D	1.03	1.10	1.00
TL8E080C16UH11	CF/CM42D	1.03	1.08	1.00
TL8E100C20UH11	CF/CM/CU36C	1.03	1.07	0.97
TL8E100C20UH11	CF/CM/CU42C	1.03	1.06	0.97
TL8E100C20UH11	CF/CM/CU48C	1.03	1.07	0.97
TL8E100C20UH11	CF/CM/CU48D	1.03	1.07	0.97
TL8E100C20UH11	CF/CM36D	1.03	1.07	0.98
TL8E100C20UH11	CF/CM42D	1.03	1.06	0.97
TL9E060B12UH11	CF/CM/CU36B	1.03	1.07	1.02
TL9E060B12UH11	CF/CM/CU36C	1.03	1.07	1.02
TL9E060B12UH11	CF/CM/CU42C	1.03	1.06	1.02
TL9E060B12UH11	CF/CM/CU48C	1.03	1.07	1.02
TL9E060B12UH11	CF42B	1.03	1.04	1.00
TL9E080C16UH11	CF/CM/CU36C	1.03	1.08	1.00
TL9E080C16UH11	CF/CM/CU42C	1.03	1.06	1.00
TL9E080C16UH11	CF/CM/CU48C	1.03	1.08	0.98
TL9E080C16UH11	CF/CM/CU48D	1.03	1.08	1.00
TL9E080C16UH11	CF/CM36D	1.03	1.09	1.00
TL9E080C16UH11	CF/CM42D	1.03	1.07	1.00
TL9E100C20UH11	CF/CM/CU36C	1.03	1.10	0.98
TL9E100C20UH11	CF/CM/CU42C	1.03	1.08	0.97
TL9E100C20UH11	CF/CM/CU48C	1.03	1.10	0.97
TL9E100C20UH11	CF/CM/CU48D	1.03	1.10	0.98
TL9E100C20UH11	CF/CM36D	1.03	1.10	0.98
TL9E100C20UH11	CF/CM42D	1.03	1.09	0.98
TM8E040A12MP11	CF/CM/CU36B	1.03	1.06	1.00
TM8E040A12MP11	CF42B	1.03	1.04	1.00
TM8E060A12MP11	CF/CM/CU36B	1.03	1.06	1.00
TM8E060A12MP11	CF42B	1.03	1.04	1.00
TM8E080B12MP11	CF/CM/CU36B	1.03	1.06	1.00
TM8E080B12MP11	CF/CM/CU36C	1.03	1.07	1.00
TM8E080B12MP11	CF/CM/CU42C	1.03	1.06	1.00
TM8E080B12MP11	CF/CM/CU48C	1.03	1.06	1.00
TM8E080B12MP11	CF42B	1.03	1.04	1.00
TM8E080C16MP11	CF/CM/CU36C	1.03	1.09	0.98
TM8E080C16MP11	CF/CM/CU42C	1.03	1.07	0.98
TM8E080C16MP11	CF/CM/CU48C	1.03	1.08	0.97
TM8E080C16MP11	CF/CM/CU48D	1.03	1.08	0.98
TM8E080C16MP11	CF/CM36D	1.03	1.10	0.98
TM8E080C16MP11	CF/CM42D	1.03	1.08	0.98
TM8E080C20MP11	CF/CM/CU36C	1.03	1.13	0.98
TM8E080C20MP11	CF/CM/CU42C	1.03	1.12	0.98
TM8E080C20MP11	CF/CM/CU48C	1.03	1.13	0.98
TM8E080C20MP11	CF/CM/CU48D	1.03	1.14	0.98
TM8E080C20MP11	CF/CM36D	1.03	1.15	0.98
TM8E080C20MP11	CF/CM42D	1.03	1.13	0.98
TM8E100B12MP11	CF/CM/CU36B	1.03	1.08	1.00
TM8E100B12MP11	CF/CM/CU36C	1.03	1.10	1.00
TM8E100B12MP11	CF/CM/CU42C	1.03	1.07	1.00
TM8E100B12MP11	CF/CM/CU48C	1.03	1.07	1.00

FURNACE MULTIPLIERS- 3 TON (Continued)

Furnaces	Coil	T.C.	S.C.	KW
TM8E100B12MP11	CF42B	1.03	1.06	1.00
TM8E100C16MP11	CF/CM/CU36C	1.03	1.10	0.98
TM8E100C16MP11	CF/CM/CU42C	1.03	1.08	0.98
TM8E100C16MP11	CF/CM/CU48C	1.03	1.10	0.98
TM8E100C16MP11	CF/CM/CU48D	1.03	1.10	0.98
TM8E100C16MP11	CF/CM36D	1.03	1.10	1.00
TM8E100C16MP11	CF/CM42D	1.03	1.08	0.98
TM8E100C20MP11	CF/CM/CU36C	1.03	1.13	0.98
TM8E100C20MP11	CF/CM/CU42C	1.03	1.12	0.98
TM8E100C20MP11	CF/CM/CU48C	1.03	1.13	0.98
TM8E100C20MP11	CF/CM/CU48D	1.03	1.14	0.98
TM8E100C20MP11	CF/CM36D	1.03	1.15	0.98
TM8E100C20MP11	CF/CM42D	1.03	1.13	0.98
TM8E120C16MP11	CF/CM/CU36C	1.03	1.10	0.98
TM8E120C16MP11	CF/CM/CU42C	1.03	1.08	0.98
TM8E120C16MP11	CF/CM/CU48C	1.03	1.10	0.98
TM8E120C16MP11	CF/CM/CU48D	1.03	1.10	0.98
TM8E120C16MP11	CF/CM36D	1.03	1.10	1.00
TM8E120C16MP11	CF/CM42D	1.03	1.08	0.98
TM8E120C20MP11	CF/CM/CU36C	1.03	1.15	0.98
TM8E120C20MP11	CF/CM/CU42C	1.03	1.13	0.98
TM8E120C20MP11	CF/CM/CU48C	1.03	1.14	0.98
TM8E120C20MP11	CF/CM/CU48D	1.03	1.14	0.98
TM8E120C20MP11	CF/CM36D	1.03	1.11	1.00
TM8E120C20MP11	CF/CM42D	1.03	1.14	1.00
TM8E130D20MP11	CF/CM/CU48D	1.03	1.14	0.98
TM8E130D20MP11	CF/CM36D	1.03	1.11	1.00
TM8E130D20MP11	CF/CM42D	1.03	1.14	0.98
TM8V080C16MP12C	CF/CM/CU36C	1.03	1.07	1.00
TM8V080C16MP12C	CF/CM/CU36D	1.03	1.07	0.97
TM8V080C16MP12C	CF/CM/CU42C	1.03	1.06	0.98
TM8V080C16MP12C	CF/CM/CU42D	1.03	1.06	0.97
TM8V080C16MP12C	CF/CM/CU48C	1.03	1.07	0.98
TM8V080C16MP12C	CF/CM/CU48D	1.03	1.07	0.98
TM8V100C16MP12C	CF/CM/CU36C	1.03	1.07	1.00
TM8V100C16MP12C	CF/CM/CU36D	1.03	1.07	0.97
TM8V100C16MP12C	CF/CM/CU42C	1.03	1.06	0.98
TM8V100C16MP12C	CF/CM/CU42D	1.03	1.06	0.97
TM8V100C16MP12C	CF/CM/CU48C	1.03	1.07	0.98
TM8V100C16MP12C	CF/CM/CU48D	1.03	1.07	0.98
TM8V100C20MP12C	CF/CM/CU36C	1.03	1.10	1.00
TM8V100C20MP12C	CF/CM/CU36D	1.03	1.10	0.97
TM8V100C20MP12C	CF/CM/CU42C	1.03	1.09	0.98
TM8V100C20MP12C	CF/CM/CU42D	1.03	1.09	0.95
TM8V100C20MP12C	CF/CM/CU48C	1.03	1.10	0.98
TM8V100C20MP12C	CF/CM/CU48D	1.03	1.10	0.95
TM8V120C20MP12C	CF/CM/CU36C	1.03	1.10	1.00
TM8V120C20MP12C	CF/CM/CU36D	1.03	1.10	0.97
TM8V120C20MP12C	CF/CM/CU42C	1.03	1.09	0.98
TM8V120C20MP12C	CF/CM/CU42D	1.03	1.09	0.95
TM8V120C20MP12C	CF/CM/CU48C	1.03	1.10	0.98
TM8V120C20MP12C	CF/CM/CU48D	1.03	1.10	0.95
TM8X060A12MP11	CF/CM36A	1.03	1.08	1.00
TM8X080B12MP11	CF/CM/CU36B	1.02	1.05	1.00
TM8X080B12MP11	CF42B	1.03	1.09	1.00
TM8X080C16MP11	CF/CM/CU36C	1.03	1.11	0.98

FURNACE MULTIPLIERS- 3 TON (Continued)

Furnaces	Coil	T.C.	S.C.	KW
TM8X080C16MP11	CF/CM/CU36D	1.03	1.06	0.98
TM8X080C16MP11	CF/CM/CU42C	1.03	1.09	0.98
TM8X080C16MP11	CF/CM/CU42D	1.03	1.03	0.98
TM8X080C16MP11	CF/CM/CU48C	1.03	1.10	0.98
TM8X080C16MP11	CF/CM/CU48D	1.03	1.05	0.97
TM8X100C16MP11	CF/CM/CU36C	1.03	1.11	0.98
TM8X100C16MP11	CF/CM/CU36D	1.03	1.06	0.98
TM8X100C16MP11	CF/CM/CU42C	1.03	1.09	0.98
TM8X100C16MP11	CF/CM/CU42D	1.03	1.03	0.98
TM8X100C16MP11	CF/CM/CU48C	1.03	1.10	0.98
TM8X100C16MP11	CF/CM/CU48D	1.03	1.05	0.97
TM8X100C20MP11	CF/CM/CU36C	1.03	1.06	0.98
TM8X100C20MP11	CF/CM/CU36D	1.03	1.06	0.98
TM8X100C20MP11	CF/CM/CU42C	1.03	1.04	0.98
TM8X100C20MP11	CF/CM/CU42D	1.03	1.04	0.98
TM8X100C20MP11	CF/CM/CU48C	1.03	1.05	0.98
TM8X100C20MP11	CF/CM/CU48D	1.03	1.05	0.98
TM8X120C20MP11	CF/CM/CU36C	1.03	1.06	0.98
TM8X120C20MP11	CF/CM/CU36D	1.03	1.06	0.98
TM8X120C20MP11	CF/CM/CU42C	1.03	1.04	0.98
TM8X120C20MP11	CF/CM/CU42D	1.03	1.04	0.98
TM8X120C20MP11	CF/CM/CU48C	1.03	1.05	0.98
TM8X120C20MP11	CF/CM/CU48D	1.03	1.05	0.98
TM8Y060A12MP11	CF/CM36A	1.03	1.08	1.00
TM8Y080B12MP11	CF/CM/CU36B	1.02	1.05	1.00
TM8Y080B12MP11	CF42B	1.03	1.09	1.00
TM8Y080C16MP11	CF/CM/CU36C	1.03	1.11	0.98
TM8Y080C16MP11	CF/CM/CU36D	1.03	1.06	0.98
TM8Y080C16MP11	CF/CM/CU42C	1.03	1.09	0.98
TM8Y080C16MP11	CF/CM/CU42D	1.03	1.03	0.98
TM8Y080C16MP11	CF/CM/CU48C	1.03	1.10	0.98
TM8Y080C16MP11	CF/CM/CU48D	1.03	1.05	0.97
TM8Y100C16MP11	CF/CM/CU36C	1.03	1.11	0.98
TM8Y100C16MP11	CF/CM/CU36D	1.03	1.06	0.98
TM8Y100C16MP11	CF/CM/CU42C	1.03	1.09	0.98
TM8Y100C16MP11	CF/CM/CU42D	1.03	1.03	0.98
TM8Y100C16MP11	CF/CM/CU48C	1.03	1.10	0.98
TM8Y100C16MP11	CF/CM/CU48D	1.03	1.05	0.97
TM8Y100C20MP11	CF/CM/CU36C	1.03	1.06	0.98
TM8Y100C20MP11	CF/CM/CU36D	1.03	1.06	0.98
TM8Y100C20MP11	CF/CM/CU42C	1.03	1.04	0.98
TM8Y100C20MP11	CF/CM/CU42D	1.03	1.04	0.98
TM8Y100C20MP11	CF/CM/CU48C	1.03	1.05	0.98
TM8Y100C20MP11	CF/CM/CU48D	1.03	1.05	0.98
TM8Y120C20MP11	CF/CM/CU36C	1.03	1.06	0.98
TM8Y120C20MP11	CF/CM/CU36D	1.03	1.06	0.98
TM8Y120C20MP11	CF/CM/CU42C	1.03	1.04	0.98
TM8Y120C20MP11	CF/CM/CU42D	1.03	1.04	0.98
TM8Y120C20MP11	CF/CM/CU48C	1.03	1.05	0.98
TM8Y120C20MP11	CF/CM/CU48D	1.03	1.05	0.98
TM9E060A10MP12	CF/CM/CU36B	1.02	1.06	1.02
TM9E060A10MP12	CF42B	1.03	1.04	1.02
TM9E060B12MP11	CF/CM/CU36B	1.03	1.09	1.02
TM9E060B12MP11	CF/CM/CU36C	1.02	1.04	0.99
TM9E060B12MP11	CF/CM/CU42C	1.03	1.03	1.00
TM9E060B12MP11	CF/CM/CU48C	1.03	1.05	1.00

FURNACE MULTIPLIERS- 3 TON (Continued)

Furnaces	Coil	T.C.	S.C.	KW
TM9E060B12MP11	CF42B	1.03	1.07	1.02
TM9E060B12MP12	CF/CM/CU36B	1.03	1.08	1.02
TM9E060B12MP12	CF/CM/CU36C	1.03	1.09	1.02
TM9E060B12MP12	CF/CM/CU42C	1.03	1.07	1.02
TM9E060B12MP12	CF/CM/CU48C	1.03	1.08	1.02
TM9E060B12MP12	CF42B	1.03	1.06	1.02
TM9E080B12MP11	CF/CM/CU36B	1.02	1.05	1.00
TM9E080B12MP11	CF42B	1.03	1.03	1.00
TM9E080B12MP12	CF/CM/CU36B	1.03	1.06	1.00
TM9E080B12MP12	CF/CM/CU36C	1.03	1.08	1.00
TM9E080B12MP12	CF/CM/CU42C	1.03	1.06	1.00
TM9E080B12MP12	CF/CM/CU48C	1.03	1.08	1.00
TM9E080B12MP12	CF42B	1.03	1.04	1.00
TM9E080C16MP11	CF/CM/CU36C	1.02	1.04	0.97
TM9E080C16MP11	CF/CM/CU42C	1.03	1.03	0.98
TM9E080C16MP11	CF/CM/CU48C	1.03	1.05	0.98
TM9E080C16MP11	CF/CM/CU48D	1.03	1.05	0.98
TM9E080C16MP11	CF/CM36D	1.02	1.04	0.97
TM9E080C16MP11	CF/CM42D	1.03	1.03	0.98
TM9E080C16MP12	CF/CM/CU36C	1.03	1.08	1.00
TM9E080C16MP12	CF/CM/CU42C	1.03	1.06	1.00
TM9E080C16MP12	CF/CM/CU48C	1.03	1.08	0.98
TM9E080C16MP12	CF/CM/CU48D	1.03	1.08	1.00
TM9E080C16MP12	CF/CM36D	1.03	1.09	1.00
TM9E080C16MP12	CF/CM42D	1.03	1.07	1.00
TM9E080C20MP12	CF/CM/CU36C	1.03	1.14	0.98
TM9E080C20MP12	CF/CM/CU42C	1.03	1.11	0.98
TM9E080C20MP12	CF/CM/CU48C	1.03	1.13	0.98
TM9E080C20MP12	CF/CM/CU48D	1.03	1.13	0.98
TM9E080C20MP12	CF/CM36D	1.03	1.13	0.98
TM9E080C20MP12	CF/CM42D	1.03	1.12	0.98
TM9E100C16MP11	CF/CM/CU36C	1.03	1.06	0.98
TM9E100C16MP11	CF/CM/CU36D	1.03	1.05	0.98
TM9E100C16MP11	CF/CM/CU42C	1.03	1.03	0.98
TM9E100C16MP11	CF/CM/CU42D	1.03	1.04	0.98
TM9E100C16MP11	CF/CM/CU48C	1.03	1.06	0.98
TM9E100C16MP11	CF/CM/CU48D	1.03	1.06	0.98
TM9E100C16MP12	CF/CM/CU36C	1.03	1.08	0.98
TM9E100C16MP12	CF/CM/CU42C	1.03	1.06	0.98
TM9E100C16MP12	CF/CM/CU48C	1.03	1.08	0.98
TM9E100C16MP12	CF/CM/CU48D	1.03	1.08	0.98
TM9E100C16MP12	CF/CM36D	1.03	1.08	1.00
TM9E100C16MP12	CF/CM42D	1.03	1.06	1.00
TM9E100C20MP11	CF/CM/CU36C	1.03	1.10	0.98
TM9E100C20MP11	CF/CM/CU36D	1.03	1.14	1.00
TM9E100C20MP11	CF/CM/CU42C	1.03	1.10	0.98
TM9E100C20MP11	CF/CM/CU42D	1.03	1.10	0.98
TM9E100C20MP11	CF/CM/CU48C	1.03	1.10	0.97
TM9E100C20MP11	CF/CM/CU48D	1.03	1.11	0.97
TM9E100C20MP12	CF/CM/CU36C	1.03	1.14	0.98
TM9E100C20MP12	CF/CM/CU42C	1.03	1.11	0.98
TM9E100C20MP12	CF/CM/CU48C	1.03	1.13	0.98
TM9E100C20MP12	CF/CM/CU48D	1.03	1.13	0.98
TM9E100C20MP12	CF/CM36D	1.03	1.14	0.98
TM9E100C20MP12	CF/CM42D	1.03	1.11	0.98
TM9E120D20MP11	CF/CM/CU36D	1.03	1.13	0.98

FURNACE MULTIPLIERS- 3 TON (Continued)

Furnaces	Coil	T.C.	S.C.	KW
TM9E120D20MP11	CF/CM/CU42D	1.03	1.12	0.98
TM9E120D20MP11	CF/CM/CU48D	1.03	1.13	0.97
TM9E120D20MP12	CF/CM/CU48D	1.03	1.13	0.98
TM9E120D20MP12	CF/CM36D	1.03	1.13	0.98
TM9E120D20MP12	CF/CM42D	1.03	1.12	0.98
TM9V060B12MP11C	CF/CM/CU36B	1.02	1.04	1.00
TM9V060B12MP11C	CF/CM/CU36C	1.03	1.06	1.00
TM9V060B12MP11C	CF/CM/CU42C	1.03	1.04	1.00
TM9V060B12MP11C	CF/CM/CU48C	1.03	1.05	1.00
TM9V060B12MP11C	CF42B	1.03	1.04	1.00
TM9V060B12MP12C	CF/CM/CU36B	1.02	1.04	1.00
TM9V060B12MP12C	CF/CM/CU36C	1.03	1.06	1.00
TM9V060B12MP12C	CF/CM/CU42C	1.03	1.04	1.00
TM9V060B12MP12C	CF/CM/CU48C	1.03	1.05	1.00
TM9V060B12MP12C	CF42B	1.03	1.04	1.00
TM9V080B12MP12C	CF/CM/CU36B	1.02	1.05	1.00
TM9V080B12MP12C	CF42B	1.03	1.03	1.00
TM9V080C16MP11C	CF/CM/CU36C	1.03	1.06	1.00
TM9V080C16MP11C	CF/CM/CU42C	1.03	1.04	0.98
TM9V080C16MP11C	CF/CM/CU48C	1.03	1.06	0.98
TM9V080C16MP11C	CF/CM/CU48D	1.03	1.06	0.98
TM9V080C16MP11C	CF/CM36D	1.03	1.06	0.98
TM9V080C16MP11C	CF/CM42D	1.03	1.04	0.98
TM9V080C16MP12C	CF/CM/CU36C	1.03	1.06	1.00
TM9V080C16MP12C	CF/CM/CU42C	1.03	1.04	0.98
TM9V080C16MP12C	CF/CM/CU48C	1.03	1.06	0.98
TM9V080C16MP12C	CF/CM/CU48D	1.03	1.06	0.98
TM9V080C16MP12C	CF/CM36D	1.03	1.06	0.98
TM9V080C16MP12C	CF/CM42D	1.03	1.04	0.98
TM9V100C16MP12C	CF/CM/CU36C	1.03	1.05	1.00
TM9V100C16MP12C	CF/CM/CU36D	1.03	1.08	0.97
TM9V100C16MP12C	CF/CM/CU42C	1.03	1.04	0.98
TM9V100C16MP12C	CF/CM/CU42D	1.03	1.06	0.97
TM9V100C16MP12C	CF/CM/CU48C	1.03	1.08	0.98
TM9V100C16MP12C	CF/CM/CU48D	1.03	1.08	0.98
TM9V100C20MP12C	CF/CM/CU36C	1.03	1.09	1.00
TM9V100C20MP12C	CF/CM/CU36D	1.03	1.09	0.97
TM9V100C20MP12C	CF/CM/CU42C	1.03	1.07	0.98
TM9V100C20MP12C	CF/CM/CU42D	1.03	1.07	0.97
TM9V100C20MP12C	CF/CM/CU48C	1.03	1.08	1.00
TM9V100C20MP12C	CF/CM/CU48D	1.03	1.08	1.00
TM9V120D20MP12C	CF/CM/CU36D	1.03	1.07	0.97
TM9V120D20MP12C	CF/CM/CU42D	1.03	1.06	0.98
TM9V120D20MP12C	CF/CM/CU48D	1.03	1.07	0.98
TM9Y060B12MP11	CF/CM/CU36B	1.03	1.09	1.02
TM9Y060B12MP11	CF/CM/CU36C	1.02	1.04	0.99
TM9Y060B12MP11	CF/CM/CU42C	1.03	1.03	1.00
TM9Y060B12MP11	CF/CM/CU48C	1.03	1.05	1.00
TM9Y060B12MP11	CF42B	1.03	1.07	1.02
TM9Y080B12MP11	CF/CM/CU36B	1.02	1.05	1.00
TM9Y080B12MP11	CF42B	1.03	1.03	1.00
TM9Y080C16MP11	CF/CM/CU36C	1.02	1.04	0.97
TM9Y080C16MP11	CF/CM/CU42C	1.03	1.03	0.98
TM9Y080C16MP11	CF/CM/CU48C	1.03	1.05	0.98
TM9Y080C16MP11	CF/CM/CU48D	1.03	1.05	0.98
TM9Y080C16MP11	CF/CM36D	1.02	1.04	0.97

FURNACE MULTIPLIERS- 3 TON (Continued)

Furnaces	Coil	T.C.	S.C.	KW
TM9Y080C16MP11	CF/CM42D	1.03	1.03	0.98
TM9Y100C16MP11	CF/CM/CU36C	1.03	1.06	0.98
TM9Y100C16MP11	CF/CM/CU36D	1.03	1.05	0.98
TM9Y100C16MP11	CF/CM/CU42C	1.03	1.03	0.98
TM9Y100C16MP11	CF/CM/CU42D	1.03	1.04	0.98
TM9Y100C16MP11	CF/CM/CU48C	1.03	1.06	0.98
TM9Y100C16MP11	CF/CM/CU48D	1.03	1.06	0.98
TM9Y100C20MP11	CF/CM/CU36C	1.03	1.10	0.98
TM9Y100C20MP11	CF/CM/CU36D	1.03	1.14	1.00
TM9Y100C20MP11	CF/CM/CU42C	1.03	1.10	0.98
TM9Y100C20MP11	CF/CM/CU42D	1.03	1.10	0.98
TM9Y100C20MP11	CF/CM/CU48C	1.03	1.10	0.97
TM9Y100C20MP11	CF/CM/CU48D	1.03	1.11	0.97
TM9Y120D20MP11	CF/CM/CU36D	1.03	1.13	0.98
TM9Y120D20MP11	CF/CM/CU42D	1.03	1.12	0.98
TM9Y120D20MP11	CF/CM/CU48D	1.03	1.13	0.97
TMLV080C16MP12C	CF/CM/CU36C	1.03	1.07	1.00
TMLV080C16MP12C	CF/CM/CU36D	1.03	1.07	0.97
TMLV080C16MP12C	CF/CM/CU42C	1.03	1.06	0.98
TMLV080C16MP12C	CF/CM/CU42D	1.03	1.06	0.97
TMLV080C16MP12C	CF/CM/CU48C	1.03	1.07	0.98
TMLV080C16MP12C	CF/CM/CU48D	1.03	1.07	0.98
TMLV100C16MP12C	CF/CM/CU36C	1.03	1.07	1.00
TMLV100C16MP12C	CF/CM/CU36D	1.03	1.07	0.97
TMLV100C16MP12C	CF/CM/CU42C	1.03	1.06	0.98
TMLV100C16MP12C	CF/CM/CU42D	1.03	1.06	0.97
TMLV100C16MP12C	CF/CM/CU48C	1.03	1.07	0.98
TMLV100C16MP12C	CF/CM/CU48D	1.03	1.07	0.98
TMLV100C20MP12C	CF/CM/CU36C	1.03	1.10	1.00
TMLV100C20MP12C	CF/CM/CU36D	1.03	1.10	0.97
TMLV100C20MP12C	CF/CM/CU42C	1.03	1.09	0.98
TMLV100C20MP12C	CF/CM/CU42D	1.03	1.09	0.95
TMLV100C20MP12C	CF/CM/CU48C	1.03	1.10	0.98
TMLV100C20MP12C	CF/CM/CU48D	1.03	1.10	0.95
TMLV120C20MP12C	CF/CM/CU36C	1.03	1.10	1.00
TMLV120C20MP12C	CF/CM/CU36D	1.03	1.10	0.97
TMLV120C20MP12C	CF/CM/CU42C	1.03	1.09	0.98
TMLV120C20MP12C	CF/CM/CU42D	1.03	1.09	0.95
TMLV120C20MP12C	CF/CM/CU48C	1.03	1.10	0.98
TMLV120C20MP12C	CF/CM/CU48D	1.03	1.10	0.95
TMLX060A12MP11	CF/CM36A	1.03	1.08	1.00
TMLX080B12MP11	CF/CM/CU36B	1.02	1.05	1.00
TMLX080B12MP11	CF42B	1.03	1.09	1.00
TMLX080C16MP11	CF/CM/CU36C	1.03	1.11	0.98
TMLX080C16MP11	CF/CM/CU36D	1.03	1.06	0.98
TMLX080C16MP11	CF/CM/CU42C	1.03	1.09	0.98
TMLX080C16MP11	CF/CM/CU42D	1.03	1.03	0.98
TMLX080C16MP11	CF/CM/CU48C	1.03	1.10	0.98
TMLX080C16MP11	CF/CM/CU48D	1.03	1.05	0.97
TMLX100C16MP11	CF/CM/CU36C	1.03	1.11	0.98
TMLX100C16MP11	CF/CM/CU36D	1.03	1.06	0.98
TMLX100C16MP11	CF/CM/CU42C	1.03	1.09	0.98
TMLX100C16MP11	CF/CM/CU42D	1.03	1.03	0.98
TMLX100C16MP11	CF/CM/CU48C	1.03	1.10	0.98
TMLX100C16MP11	CF/CM/CU48D	1.03	1.05	0.97
TMLX100C20MP11	CF/CM/CU36C	1.03	1.06	0.98

FURNACE MULTIPLIERS- 3 TON (Continued)

Furnaces	Coil	T.C.	S.C.	KW
TMLX100C20MP11	CF/CM/CU36D	1.03	1.06	0.98
TMLX100C20MP11	CF/CM/CU42C	1.03	1.04	0.98
TMLX100C20MP11	CF/CM/CU42D	1.03	1.04	0.98
TMLX100C20MP11	CF/CM/CU48C	1.03	1.05	0.98
TMLX100C20MP11	CF/CM/CU48D	1.03	1.05	0.98
TMLX120C20MP11	CF/CM/CU36C	1.03	1.06	0.98
TMLX120C20MP11	CF/CM/CU36D	1.03	1.06	0.98
TMLX120C20MP11	CF/CM/CU42C	1.03	1.04	0.98
TMLX120C20MP11	CF/CM/CU42D	1.03	1.04	0.98
TMLX120C20MP11	CF/CM/CU48C	1.03	1.05	0.98
TMLX120C20MP11	CF/CM/CU48D	1.03	1.05	0.98
TP9C060B12MP13C	CF/CM/CU36B	1.02	1.04	1.00
TP9C060B12MP13C	CF/CM/CU36C	1.03	1.06	1.00
TP9C060B12MP13C	CF/CM/CU42C	1.03	1.04	1.00
TP9C060B12MP13C	CF/CM/CU48C	1.03	1.05	1.00
TP9C060B12MP13C	CF42B	1.03	1.04	1.00
TP9C080B12MP13C	CF/CM/CU36B	1.02	1.05	1.00
TP9C080B12MP13C	CF42B	1.03	1.03	1.00
TP9C080C16MP13C	CF/CM/CU36C	1.03	1.06	1.00
TP9C080C16MP13C	CF/CM/CU42C	1.03	1.04	0.98
TP9C080C16MP13C	CF/CM/CU48C	1.03	1.06	0.98
TP9C080C16MP13C	CF/CM/CU48D	1.03	1.06	0.98
TP9C080C16MP13C	CF/CM36D	1.03	1.06	0.98
TP9C080C16MP13C	CF/CM42D	1.03	1.04	0.98
TP9C100C16MP13C	CF/CM/CU36C	1.03	1.05	1.00
TP9C100C16MP13C	CF/CM/CU36D	1.03	1.08	0.97
TP9C100C16MP13C	CF/CM/CU42C	1.03	1.04	0.98
TP9C100C16MP13C	CF/CM/CU42D	1.03	1.06	0.97
TP9C100C16MP13C	CF/CM/CU48C	1.03	1.08	0.98
TP9C100C16MP13C	CF/CM/CU48D	1.03	1.08	0.98
TP9C100C20MP13C	CF/CM/CU36C	1.03	1.09	1.00
TP9C100C20MP13C	CF/CM/CU36D	1.03	1.09	0.97
TP9C100C20MP13C	CF/CM/CU42C	1.03	1.07	0.98
TP9C100C20MP13C	CF/CM/CU42D	1.03	1.07	0.97
TP9C100C20MP13C	CF/CM/CU48C	1.03	1.08	1.00
TP9C100C20MP13C	CF/CM/CU48D	1.03	1.08	1.00
TP9C120D20MP13C	CF/CM/CU36D	1.03	1.07	0.97
TP9C120D20MP13C	CF/CM/CU42D	1.03	1.06	0.98
TP9C120D20MP13C	CF/CM/CU48D	1.03	1.07	0.98
TPLC080C16MP13C	CF/CM/CU36C	1.03	1.07	1.00
TPLC080C16MP13C	CF/CM/CU36D	1.03	1.07	0.97
TPLC080C16MP13C	CF/CM/CU42C	1.03	1.06	0.98
TPLC080C16MP13C	CF/CM/CU42D	1.03	1.06	0.97
TPLC080C16MP13C	CF/CM/CU48C	1.03	1.07	0.98
TPLC080C16MP13C	CF/CM/CU48D	1.03	1.07	0.98
TPLC100C16MP13C	CF/CM/CU36C	1.03	1.07	1.00
TPLC100C16MP13C	CF/CM/CU36D	1.03	1.07	0.97
TPLC100C16MP13C	CF/CM/CU42C	1.03	1.06	0.98
TPLC100C16MP13C	CF/CM/CU42D	1.03	1.06	0.97
TPLC100C16MP13C	CF/CM/CU48C	1.03	1.07	0.98
TPLC100C16MP13C	CF/CM/CU48D	1.03	1.07	0.98
TPLC100C20MP13C	CF/CM/CU36C	1.03	1.10	1.00
TPLC100C20MP13C	CF/CM/CU36D	1.03	1.10	0.97
TPLC100C20MP13C	CF/CM/CU42C	1.03	1.09	0.98
TPLC100C20MP13C	CF/CM/CU42D	1.03	1.09	0.95
TPLC100C20MP13C	CF/CM/CU48C	1.03	1.10	0.98

FURNACE MULTIPLIERS- 3 TON (Continued)

Furnaces	Coil	T.C.	S.C.	KW
TPLC100C20MP13C	CF/CM/CU48D	1.03	1.10	0.95
TPLC120C20MP13C	CF/CM/CU36C	1.03	1.10	1.00
TPLC120C20MP13C	CF/CM/CU36D	1.03	1.10	0.97
TPLC120C20MP13C	CF/CM/CU42C	1.03	1.09	0.98
TPLC120C20MP13C	CF/CM/CU42D	1.03	1.09	0.95
TPLC120C20MP13C	CF/CM/CU48C	1.03	1.10	0.98
TPLC120C20MP13C	CF/CM/CU48D	1.03	1.10	0.95
CP9C060B12MP13C	CF/CM/CU36B	1.02	1.04	1.00
CP9C060B12MP13C	CF/CM/CU36C	1.03	1.06	1.00
CP9C060B12MP13C	CF/CM/CU42C	1.03	1.04	1.00
CP9C060B12MP13C	CF/CM/CU48C	1.03	1.05	1.00
CP9C060B12MP13C	CF42B	1.03	1.04	1.00
CP9C080B12MP13C	CF/CM/CU36B	1.02	1.05	1.00
CP9C080B12MP13C	CF42B	1.03	1.03	1.00
CP9C080C16MP13C	CF/CM/CU36C	1.03	1.06	1.00
CP9C080C16MP13C	CF/CM/CU42C	1.03	1.04	0.98
CP9C080C16MP13C	CF/CM/CU48C	1.03	1.06	0.98
CP9C080C16MP13C	CF/CM/CU48D	1.03	1.06	0.98
CP9C080C16MP13C	CF/CM36D	1.03	1.06	0.98
CP9C080C16MP13C	CF/CM42D	1.03	1.04	0.98
CP9C100C16MP13C	CF/CM/CU36C	1.03	1.05	1.00
CP9C100C16MP13C	CF/CM/CU36D	1.03	1.08	0.97
CP9C100C16MP13C	CF/CM/CU42C	1.03	1.04	0.98
CP9C100C16MP13C	CF/CM/CU42D	1.03	1.06	0.97
CP9C100C16MP13C	CF/CM/CU48C	1.03	1.08	0.98
CP9C100C16MP13C	CF/CM/CU48D	1.03	1.08	0.98
CP9C100C20MP13C	CF/CM/CU36C	1.03	1.09	1.00
CP9C100C20MP13C	CF/CM/CU36D	1.03	1.09	0.97
CP9C100C20MP13C	CF/CM/CU42C	1.03	1.07	0.98
CP9C100C20MP13C	CF/CM/CU42D	1.03	1.07	0.97
CP9C100C20MP13C	CF/CM/CU48C	1.03	1.08	1.00

FURNACE MULTIPLIERS- 3 TON (Continued)

Furnaces	Coil	T.C.	S.C.	KW
CP9C100C20MP13C	CF/CM/CU48D	1.03	1.08	1.00
CP9C120D20MP13C	CF/CM/CU36D	1.03	1.07	0.97
CP9C120D20MP13C	CF/CM/CU42D	1.03	1.06	0.98
CP9C120D20MP13C	CF/CM/CU48D	1.03	1.07	0.98
CPLC080C16MP13C	CF/CM/CU36C	1.03	1.07	1.00
CPLC080C16MP13C	CF/CM/CU36D	1.03	1.07	0.97
CPLC080C16MP13C	CF/CM/CU42C	1.03	1.06	0.98
CPLC080C16MP13C	CF/CM/CU42D	1.03	1.06	0.97
CPLC080C16MP13C	CF/CM/CU48C	1.03	1.07	0.98
CPLC080C16MP13C	CF/CM/CU48D	1.03	1.07	0.98
CPLC100C16MP13C	CF/CM/CU36C	1.03	1.07	1.00
CPLC100C16MP13C	CF/CM/CU36D	1.03	1.07	0.97
CPLC100C16MP13C	CF/CM/CU42C	1.03	1.06	0.98
CPLC100C16MP13C	CF/CM/CU42D	1.03	1.06	0.97
CPLC100C16MP13C	CF/CM/CU48C	1.03	1.07	0.98
CPLC100C16MP13C	CF/CM/CU48D	1.03	1.07	0.98
CPLC100C20MP13C	CF/CM/CU36C	1.03	1.10	1.00
CPLC100C20MP13C	CF/CM/CU36D	1.03	1.10	0.97
CPLC100C20MP13C	CF/CM/CU42C	1.03	1.09	0.98
CPLC100C20MP13C	CF/CM/CU42D	1.03	1.09	0.95
CPLC100C20MP13C	CF/CM/CU48C	1.03	1.10	0.98
CPLC100C20MP13C	CF/CM/CU48D	1.03	1.10	0.95
CPLC120C20MP13C	CF/CM/CU36C	1.03	1.10	1.00
CPLC120C20MP13C	CF/CM/CU36D	1.03	1.10	0.97
CPLC120C20MP13C	CF/CM/CU42C	1.03	1.09	0.98
CPLC120C20MP13C	CF/CM/CU42D	1.03	1.09	0.95
CPLC120C20MP13C	CF/CM/CU48C	1.03	1.10	0.98
CPLC120C20MP13C	CF/CM/CU48D	1.03	1.10	0.95

PERFORMANCE DATA - 3.5 TON

CONDENSER-ONLY DATA (OUTDOOR UNIT)																		
MODEL	SATURATED SUCTION @ COMPRESSOR		Outdoor Ambient Temperature															
			55 °F		65 °F		75 °F		85 °F		95 °F		105 °F		115 °F		125 °F	
	T (°F)	P (PSIG)	MBH	KW	MBH	KW	MBH	KW	MBH	KW	MBH	KW	MBH	KW	MBH	KW	MBH	KW
TW4B4221S	35	107	37.5	1.82	35.8	2.04	34.1	2.29	32.2	2.56	30.3	2.87	28.3	3.23	26.2	3.64	24.0	4.09
	40	118	41.4	1.81	39.4	2.03	37.5	2.27	35.5	2.55	33.4	2.86	31.2	3.22	28.9	3.63	26.5	4.08
	45	130	45.5	1.81	43.4	2.02	41.2	2.26	39.0	2.54	36.8	2.85	34.4	3.21	31.9	3.62	29.3	4.07
	50	142	50.0	1.80	47.6	2.01	45.3	2.25	42.9	2.53	40.4	2.83	37.8	3.19	35.1	3.61	32.3	4.05
	55	156	54.8	1.79	52.2	2.00	49.6	2.24	47.0	2.51	44.3	2.81	41.5	3.18	38.6	3.59	35.5	4.03

Notes:

- For Outdoor Unit (Condenser) performance only. Data does not include the effects of air handler power or heat.
- Performance based on 15°F subcooling and 15°F superheat at the Outdoor Unit base valves.
 - Increase capacity by 1% for each 2°F increase in subcooling.
 - Decrease capacity by 1% for each 2°F decrease in subcooling.
- Maximum recommended condensing temperature is 140°F.

COOLING PERFORMANCE DATA																
OUTDOOR UNIT MODEL NO.		TW4B4221S														
INDOOR COIL MODEL NO.		CF42CXA1														
AIR TEMP. ENTERING OUTDOOR UNIT (°F)	ID CFM	1200					1400					1600				
	ID DB (°F)	80	80	75	80	80	80	80	75	80	80	80	80	75	80	80
	ID WB (°F)	57	62	62	67	72	57	62	62	67	72	57	62	62	67	72
55	T.C.	38.7	42.0	41.9	44.4	45.5	39.0	42.0	41.7	44.0	45.0	39.3	42.0	41.6	43.7	44.5
	S.C.	36.8	35.3	30.3	29.0	22.7	37.1	36.0	31.1	29.4	22.9	37.4	36.6	31.9	29.8	23.1
	KW	2.18	2.18	2.18	2.19	2.20	2.24	2.25	2.25	2.26	2.27	2.31	2.32	2.32	2.34	2.34
65	T.C.	37.8	40.7	40.5	43.5	46.1	38.5	40.9	40.7	43.6	45.8	39.1	41.1	40.9	43.7	45.5
	S.C.	36.0	35.0	29.9	29.2	23.1	36.6	36.2	31.2	30.2	23.6	37.2	37.4	32.6	31.2	24.0
	KW	2.39	2.40	2.39	2.41	2.40	2.45	2.47	2.46	2.48	2.48	2.52	2.54	2.53	2.55	2.55
75	T.C.	36.9	39.3	39.0	42.6	46.7	37.9	39.8	39.6	43.2	46.6	38.9	40.3	40.3	43.8	46.6
	S.C.	35.1	34.6	29.5	29.4	23.5	36.1	36.4	31.4	31.0	24.2	37.0	38.3	33.3	32.6	25.0
	KW	2.60	2.62	2.60	2.62	2.61	2.66	2.69	2.67	2.69	2.69	2.73	2.75	2.74	2.76	2.76
85	T.C.	35.9	37.7	37.4	41.0	45.2	36.8	38.2	38.1	41.6	45.3	37.7	38.7	38.7	42.2	45.4
	S.C.	34.1	33.7	28.8	28.7	23.0	35.0	35.3	30.7	30.5	24.0	35.8	36.8	32.6	32.3	25.1
	KW	2.90	2.93	2.90	2.92	2.89	2.96	2.98	2.96	2.99	2.96	3.01	3.04	3.02	3.05	3.04
95	T.C.	34.8	36.1	35.8	39.4	43.7	35.6	36.7	36.5	40.0	44.0	36.4	37.2	37.1	40.6	44.3
	S.C.	33.1	32.8	28.1	28.0	22.5	33.9	34.1	30.0	30.0	23.8	34.6	35.4	31.9	32.0	25.2
	KW	3.20	3.23	3.20	3.22	3.17	3.25	3.28	3.25	3.28	3.24	3.30	3.33	3.31	3.33	3.31
105	T.C.	32.6	33.8	33.3	37.0	41.0	33.6	34.4	34.0	37.6	41.3	34.5	35.1	34.6	38.1	41.7
	S.C.	31.0	31.1	26.8	27.0	21.5	31.9	32.2	28.7	29.0	22.9	32.8	33.3	30.7	31.0	24.3
	KW	3.84	3.82	3.84	3.74	3.67	3.81	3.82	3.83	3.78	3.72	3.78	3.81	3.81	3.81	3.77
115	T.C.	30.5	31.6	30.9	34.7	38.4	31.6	32.2	31.5	35.2	38.8	32.6	32.9	32.2	35.7	39.2
	S.C.	29.0	29.5	25.5	26.0	20.6	30.0	30.4	27.5	28.0	22.1	31.0	31.3	29.5	30.0	23.5
	KW	4.46	4.38	4.46	4.25	4.16	4.35	4.33	4.38	4.26	4.19	4.24	4.28	4.30	4.28	4.22
125	T.C.	28.4	29.3	28.4	32.3	35.7	29.6	30.1	29.1	32.8	36.2	30.7	30.8	29.8	33.3	36.7
	S.C.	27.0	27.9	24.2	25.0	19.7	28.1	28.6	26.3	27.0	21.2	29.2	29.3	28.3	29.1	22.7
	KW	5.08	4.95	5.09	4.75	4.65	4.89	4.85	4.94	4.75	4.66	4.71	4.75	4.79	4.75	4.68

NOTE: ALL CAPACITIES INCLUDE INDOOR FAN HEAT. KW VALUES ARE FOR THE SYSTEM (OUTDOOR + INDOOR).

Green shaded cells are ACCA (TVA) conditions.

Blue shaded cells are AHRI conditions.

Multipliers for determining the performance with other indoor sections.

NOTE: For dry bulb temperatures different than those listed (between 73-87 °F), sensible capacity increases by 1060 BTUH per 1000 CFM per degree above the listed temperature and decreases by 1060 BTUH per 1000 CFM per degree below the listed temperature.

COIL MULTIPLIERS- 3.5 TON

Air Handler	Coil	T.C.	S.C.	KW
-	CF/CM/CU42C	1.00	1.00	1.00
-	CF/CM/CU42D	1.00	1.00	1.00
-	CF/CM/CU48C	1.01	1.07	1.01
-	CF/CM/CU48D	1.01	1.07	1.01
-	CF/CM/CU60C	1.03	1.08	1.02
-	CF/CM/CU60D	1.03	1.08	1.02
-	CF/CM64D	1.04	1.08	1.03
-	CF42B	0.96	0.97	0.96
AE42CX21	-	1.04	1.10	1.01
AE48CX21	-	1.03	1.02	0.98
AE48DX21	-	1.03	1.03	0.98
AE60CX21	-	1.05	1.12	1.02
AE60DX21	-	1.05	1.12	1.00
AP42CX21	-	1.00	1.00	1.00
AP48CX21	-	1.01	1.03	1.01
AP48DX21	-	1.01	1.05	1.01
AVC42CX21	-	1.03	1.03	1.00
AVC48CX21	-	1.01	1.02	0.99
AVC48DX21	-	1.04	1.07	0.99
AVC60CX21	-	1.04	1.05	1.01
AVC60DX21	-	1.04	1.02	0.99
ME14DN21	CF/CM42D	1.04	1.10	0.99
ME14DN21	CF/CM48D	1.04	1.10	1.01
ME14DN21	CF/CM60D	1.04	1.03	0.97
ME14DN21	CF/CM64D	1.05	1.10	1.02
ME16CN21	CF/CM42C	1.03	1.10	1.00
ME16CN21	CF/CM48C	1.03	1.02	0.98
ME16CN21	CF/CM60C	1.04	1.03	0.97
ME20DN21	CF/CM42D	1.04	1.12	1.01
ME20DN21	CF/CM48D	1.05	1.13	1.00
ME20DN21	CF/CM60D	1.05	1.10	1.00
ME20DN21	CF/CM64D	1.05	1.10	1.00
MVC12BN21	CF42B	1.00	0.97	1.00
MVC14DN21	CF/CM42D	1.04	1.08	1.01
MVC14DN21	CF/CM48D	1.04	1.07	0.99
MVC14DN21	CF/CM60D	1.03	1.03	0.98
MVC16CN21	CF/CM42C	1.03	1.03	0.98
MVC16CN21	CF/CM48C	1.03	1.05	0.98
MVC20DN21	CF/CM42D	1.01	1.02	0.99
MVC20DN21	CF/CM48D	1.04	1.07	0.99
MVC20DN21	CF/CM60D	1.04	1.05	0.97

FURNACE MULTIPLIERS- 3.5 TON

Furnaces	Coil	T.C.	S.C.	KW
TL8E080C16UH11	CF/CM/CU42C	1.01	1.04	0.99
TL8E080C16UH11	CF/CM/CU48C	1.03	1.04	1.00
TL8E080C16UH11	CF/CM/CU48D	1.03	1.05	1.00
TL8E080C16UH11	CF/CM/CU60C	1.01	1.02	0.99
TL8E080C16UH11	CF/CM42D	1.01	1.05	0.99
TL8E080C16UH11	CF/CM64D	1.05	1.07	1.02
TL8E100C20UH11	CF/CM/CU42C	1.01	1.03	0.99
TL8E100C20UH11	CF/CM/CU48C	1.03	1.03	0.98
TL8E100C20UH11	CF/CM/CU48D	1.03	1.04	1.00
TL8E100C20UH11	CF/CM/CU60C	1.01	1.01	0.99
TL8E100C20UH11	CF/CM42D	1.03	1.05	1.00
TL8E100C20UH11	CF/CM64D	1.05	1.06	1.00

FURNACE MULTIPLIERS- 3.5 TON (Continued)

Furnaces	Coil	T.C.	S.C.	KW
TL9E060B12UH11	CF/CM/CU42C	1.00	1.00	1.00
TL9E060B12UH11	CF/CM/CU48C	1.01	1.01	1.01
TL9E060B12UH11	CF/CM/CU60C	1.00	0.99	1.00
TL9E080C16UH11	CF/CM/CU42C	1.01	1.03	0.99
TL9E080C16UH11	CF/CM/CU48C	1.03	1.03	1.00
TL9E080C16UH11	CF/CM/CU48D	1.03	1.04	1.00
TL9E080C16UH11	CF/CM/CU60C	1.01	1.01	0.99
TL9E080C16UH11	CF/CM42D	1.01	1.04	0.99
TL9E080C16UH11	CF/CM64D	1.04	1.05	1.01
TL9E100C20UH11	CF/CM/CU42C	1.01	1.01	0.99
TL9E100C20UH11	CF/CM/CU48C	1.03	1.03	1.00
TL9E100C20UH11	CF/CM/CU48D	1.03	1.03	1.00
TL9E100C20UH11	CF/CM/CU60C	1.01	1.00	0.99
TL9E100C20UH11	CF/CM42D	1.01	1.03	0.99
TL9E100C20UH11	CF/CM64D	1.04	1.03	0.99
TM8V080C16MP11C	CF/CM/CU42C	1.00	1.03	0.98
TM8V080C16MP11C	CF/CM/CU48C	1.03	1.07	1.00
TM8V080C16MP11C	CF/CM/CU48D	1.03	1.07	1.00
TM8V080C16MP11C	CF/CM/CU60C	1.01	1.03	0.99
TM8V080C16MP11C	CF/CM64D	1.05	1.10	1.02
TM8V080C16MP12C	CF/CM/CU42C	1.00	1.03	0.98
TM8V080C16MP12C	CF/CM/CU42D	1.00	1.03	0.96
TM8V080C16MP12C	CF/CM/CU48C	1.03	1.07	1.00
TM8V080C16MP12C	CF/CM/CU48D	1.03	1.07	1.00
TM8V080C16MP12C	CF/CM/CU60C	1.01	1.03	0.99
TM8V080C16MP12C	CF/CM/CU60D	1.04	1.11	0.97
TM8V080C16MP12C	CF/CM64D	1.05	1.10	1.02
TM8V100C16MP11C	CF/CM/CU42C	1.00	1.03	0.98
TM8V100C16MP11C	CF/CM/CU48C	1.03	1.07	1.00
TM8V100C16MP11C	CF/CM/CU48D	1.03	1.07	1.00
TM8V100C16MP11C	CF/CM/CU60C	1.01	1.03	0.99
TM8V100C16MP11C	CF/CM64D	1.05	1.10	1.02
TM8V100C16MP12C	CF/CM/CU42C	1.00	1.03	0.98
TM8V100C16MP12C	CF/CM/CU42D	1.00	1.03	0.96
TM8V100C16MP12C	CF/CM/CU48C	1.03	1.07	1.00
TM8V100C16MP12C	CF/CM/CU48D	1.03	1.07	1.00
TM8V100C16MP12C	CF/CM/CU60C	1.01	1.03	0.99
TM8V100C16MP12C	CF/CM/CU60D	1.04	1.11	0.97
TM8V100C16MP12C	CF/CM64D	1.05	1.10	1.02
TM8V100C20MP11C	CF/CM/CU42C	1.01	1.05	0.99
TM8V100C20MP11C	CF/CM/CU48C	1.03	1.05	1.00
TM8V100C20MP11C	CF/CM/CU60C	1.05	1.12	1.02
TM8V100C20MP11C	CF/CM/CU60D	1.05	1.13	1.02
TM8V100C20MP11C	CF/CM64D	1.05	1.10	1.00
TM8V100C20MP12C	CF/CM/CU42C	1.01	1.05	0.99
TM8V100C20MP12C	CF/CM/CU42D	1.01	1.05	0.95
TM8V100C20MP12C	CF/CM/CU48C	1.03	1.05	1.00
TM8V100C20MP12C	CF/CM/CU48D	1.04	1.09	0.97
TM8V100C20MP12C	CF/CM/CU60C	1.05	1.12	1.02
TM8V100C20MP12C	CF/CM/CU60D	1.05	1.13	1.02
TM8V100C20MP12C	CF/CM64D	1.05	1.10	1.00
TM8V120C20MP12C	CF/CM/CU42C	1.01	1.05	0.99
TM8V120C20MP12C	CF/CM/CU42D	1.01	1.05	0.95
TM8V120C20MP12C	CF/CM/CU48C	1.03	1.05	1.00
TM8V120C20MP12C	CF/CM/CU48D	1.04	1.09	0.97
TM8V120C20MP12C	CF/CM/CU60C	1.05	1.12	1.02

FURNACE MULTIPLIERS- 3.5 TON (Continued)

Furnaces	Coil	T.C.	S.C.	KW
TM8V120C20MP12C	CF/CM/CU60D	1.05	1.13	1.02
TM8V120C20MP12C	CF/CM64D	1.05	1.10	1.00
TM8X080C16MP11	CF/CM/CU42C	1.03	1.09	1.00
TM8X080C16MP11	CF/CM/CU42D	0.99	0.97	0.96
TM8X080C16MP11	CF/CM/CU48C	1.03	1.07	1.00
TM8X080C16MP11	CF/CM/CU48D	1.04	1.09	1.01
TM8X080C16MP11	CF/CM/CU60C	1.04	1.09	1.01
TM8X080C16MP11	CF/CM/CU60D	1.04	1.10	1.01
TM8X080C16MP11	CF/CM42D	0.99	0.97	0.96
TM8X080C16MP11	CF/CM64D	1.05	1.10	1.02
TM8X100C16MP11	CF/CM/CU42C	1.03	1.09	1.00
TM8X100C16MP11	CF/CM/CU42D	0.99	0.97	0.96
TM8X100C16MP11	CF/CM/CU48C	1.03	1.07	1.00
TM8X100C16MP11	CF/CM/CU48D	1.04	1.09	1.01
TM8X100C16MP11	CF/CM/CU60C	1.04	1.09	1.01
TM8X100C16MP11	CF/CM/CU60D	1.04	1.10	1.01
TM8X100C16MP11	CF/CM42D	0.99	0.97	0.96
TM8X100C16MP11	CF/CM64D	1.05	1.10	1.02
TM8X100C20MP11	CF/CM/CU42C	1.03	1.08	1.00
TM8X100C20MP11	CF/CM/CU42D	1.00	1.02	0.96
TM8X100C20MP11	CF/CM/CU48C	1.04	1.09	1.01
TM8X100C20MP11	CF/CM/CU48D	1.04	1.10	0.99
TM8X100C20MP11	CF/CM/CU60C	1.04	1.09	0.99
TM8X100C20MP11	CF/CM/CU60D	1.05	1.13	1.00
TM8X100C20MP11	CF/CM42D	0.99	0.97	0.96
TM8X100C20MP11	CF/CM64D	1.05	1.11	1.00
TM8X120C20MP11	CF/CM/CU42C	1.03	1.08	1.00
TM8X120C20MP11	CF/CM/CU42D	1.00	1.02	0.96
TM8X120C20MP11	CF/CM/CU48C	1.04	1.09	1.01
TM8X120C20MP11	CF/CM/CU48D	1.04	1.10	0.99
TM8X120C20MP11	CF/CM/CU60C	1.04	1.09	0.99
TM8X120C20MP11	CF/CM/CU60D	1.05	1.13	1.00
TM8X120C20MP11	CF/CM42D	1.00	1.02	0.96
TM8X120C20MP11	CF/CM64D	1.05	1.11	1.00
TM8Y080B12MP11	CF42B	1.00	0.98	0.98
TM8Y080C16MP11	CF/CM/CU42C	1.03	1.09	1.00
TM8Y080C16MP11	CF/CM/CU42D	0.99	0.97	0.96
TM8Y080C16MP11	CF/CM/CU48C	1.03	1.07	1.00
TM8Y080C16MP11	CF/CM/CU48D	1.04	1.09	1.01
TM8Y080C16MP11	CF/CM/CU60C	1.04	1.09	1.01
TM8Y080C16MP11	CF/CM/CU60D	1.04	1.10	1.01
TM8Y080C16MP11	CF/CM42D	0.99	0.97	0.96
TM8Y080C16MP11	CF/CM64D	1.05	1.10	1.02
TM8Y100C16MP11	CF/CM/CU42C	1.03	1.09	1.00
TM8Y100C16MP11	CF/CM/CU42D	0.99	0.97	0.96
TM8Y100C16MP11	CF/CM/CU48C	1.03	1.07	1.00
TM8Y100C16MP11	CF/CM/CU48D	1.04	1.09	1.01
TM8Y100C16MP11	CF/CM/CU60C	1.04	1.09	1.01
TM8Y100C16MP11	CF/CM/CU60D	1.04	1.10	1.01
TM8Y100C16MP11	CF/CM42D	0.99	0.97	0.96
TM8Y100C16MP11	CF/CM64D	1.05	1.10	1.02
TM8Y100C20MP11	CF/CM/CU42C	1.03	1.08	1.00
TM8Y100C20MP11	CF/CM/CU42D	1.00	1.02	0.96
TM8Y100C20MP11	CF/CM/CU48C	1.04	1.09	1.01
TM8Y100C20MP11	CF/CM/CU48D	1.04	1.10	0.99
TM8Y100C20MP11	CF/CM/CU60C	1.04	1.09	0.99

FURNACE MULTIPLIERS- 3.5 TON (Continued)

Furnaces	Coil	T.C.	S.C.	KW
TM8Y100C20MP11	CF/CM/CU60D	1.05	1.13	1.00
TM8Y100C20MP11	CF/CM42D	1.00	1.02	0.96
TM8Y100C20MP11	CF/CM64D	1.05	1.11	1.00
TM8Y120C20MP11	CF/CM/CU42C	1.03	1.08	1.00
TM8Y120C20MP11	CF/CM/CU42D	1.00	1.02	0.96
TM8Y120C20MP11	CF/CM/CU48C	1.04	1.09	1.01
TM8Y120C20MP11	CF/CM/CU48D	1.04	1.10	0.99
TM8Y120C20MP11	CF/CM/CU60C	1.04	1.09	0.99
TM8Y120C20MP11	CF/CM/CU60D	1.05	1.13	1.00
TM8Y120C20MP11	CF/CM42D	1.00	1.02	0.96
TM8Y120C20MP11	CF/CM64D	1.05	1.11	1.00
TM9E080C16MP11	CF/CM/CU42C	1.01	1.03	0.99
TM9E080C16MP11	CF/CM/CU48C	1.03	1.04	1.00
TM9E080C16MP11	CF/CM/CU48D	1.03	1.04	1.00
TM9E080C16MP11	CF/CM/CU60C	1.01	1.01	0.99
TM9E080C16MP11	CF/CM/CU60D	1.01	1.02	0.99
TM9E080C16MP11	CF/CM42D	1.01	1.04	0.99
TM9E080C16MP11	CF/CM64D	1.04	1.05	0.99
TM9E100C16MP11	CF/CM/CU42C	1.00	1.03	0.98
TM9E100C16MP11	CF/CM/CU42D	0.99	0.97	0.96
TM9E100C16MP11	CF/CM/CU48C	1.00	1.01	0.98
TM9E100C16MP11	CF/CM/CU48D	1.01	1.03	0.99
TM9E100C16MP11	CF/CM/CU60C	1.01	1.03	0.99
TM9E100C16MP11	CF/CM/CU60D	1.01	1.05	0.99
TM9E100C16MP11	CF/CM42D	0.99	0.97	0.96
TM9E100C16MP11	CF/CM64D	1.03	1.04	0.98
TM9E100C20MP11	CF/CM/CU42C	1.01	1.06	0.99
TM9E100C20MP11	CF/CM/CU42D	0.99	0.98	0.96
TM9E100C20MP11	CF/CM/CU48C	1.03	1.06	1.00
TM9E100C20MP11	CF/CM/CU48D	1.03	1.07	1.00
TM9E100C20MP11	CF/CM/CU60C	1.03	1.07	0.98
TM9E100C20MP11	CF/CM/CU60D	0.99	0.99	0.94
TM9E100C20MP11	CF/CM42D	0.99	0.98	0.96
TM9E100C20MP11	CF/CM64D	1.05	1.10	1.00
TM9E120D20MP11	CF/CM/CU42D	1.00	1.02	0.96
TM9E120D20MP11	CF/CM/CU48D	1.00	1.01	0.96
TM9E120D20MP11	CF/CM/CU60D	1.05	1.13	1.00
TM9E120D20MP11	CF/CM42D	1.00	1.02	0.96
TM9E120D20MP11	CF/CM64D	1.05	1.11	1.00
TM9V080B12MP11C	CF42B	0.98	0.95	0.97
TM9V080B12MP12C	CF42B	0.98	0.95	0.97
TM9V080C16MP11C	CF/CM/CU42C	1.01	1.01	0.99
TM9V080C16MP11C	CF/CM/CU48C	1.01	1.01	0.99
TM9V080C16MP11C	CF/CM/CU48D	1.01	1.01	0.99
TM9V080C16MP11C	CF/CM/CU60C	1.01	1.00	0.99
TM9V080C16MP11C	CF/CM/CU60D	1.01	1.01	0.99
TM9V080C16MP11C	CF/CM42D	1.01	1.01	0.99
TM9V080C16MP11C	CF/CM64D	1.04	1.03	1.01
TM9V080C16MP12C	CF/CM/CU42C	1.01	1.01	0.99
TM9V080C16MP12C	CF/CM/CU48C	1.01	1.01	0.99
TM9V080C16MP12C	CF/CM/CU48D	1.01	1.01	0.99
TM9V080C16MP12C	CF/CM/CU60C	1.01	1.00	0.99
TM9V080C16MP12C	CF/CM/CU60D	1.01	1.01	0.99
TM9V080C16MP12C	CF/CM42D	1.01	1.01	0.99
TM9V080C16MP12C	CF/CM64D	1.04	1.03	1.01
TM9V100C16MP11C	CF/CM/CU42C	1.01	1.05	0.99

FURNACE MULTIPLIERS- 3.5 TON (Continued)

Furnaces	Coil	T.C.	S.C.	KW
TM9V100C16MP11C	CF/CM/CU48C	1.01	1.03	0.99
TM9V100C16MP11C	CF/CM/CU48D	1.01	1.03	0.99
TM9V100C16MP11C	CF/CM/CU60C	1.01	1.03	0.99
TM9V100C16MP11C	CF/CM/CU60D	1.01	1.04	0.99
TM9V100C16MP11C	CF/CM64D	1.03	1.05	1.00
TM9V100C16MP12C	CF/CM/CU42C	1.01	1.05	0.99
TM9V100C16MP12C	CF/CM/CU42D	1.00	1.03	0.96
TM9V100C16MP12C	CF/CM/CU48C	1.01	1.03	0.99
TM9V100C16MP12C	CF/CM/CU48D	1.01	1.03	0.99
TM9V100C16MP12C	CF/CM/CU60C	1.01	1.03	0.99
TM9V100C16MP12C	CF/CM/CU60D	1.01	1.04	0.99
TM9V100C16MP12C	CF/CM64D	1.03	1.05	1.00
TM9V100C20MP11C	CF/CM/CU42C	0.99	0.99	0.96
TM9V100C20MP11C	CF/CM/CU48C	1.03	1.06	1.00
TM9V100C20MP11C	CF/CM/CU48D	1.03	1.06	1.00
TM9V100C20MP11C	CF/CM/CU60C	1.03	1.06	1.00
TM9V100C20MP11C	CF/CM/CU60D	1.03	1.06	1.00
TM9V100C20MP11C	CF/CM64D	1.04	1.08	1.01
TM9V100C20MP12C	CF/CM/CU42C	0.99	0.99	0.96
TM9V100C20MP12C	CF/CM/CU42D	1.01	1.06	0.97
TM9V100C20MP12C	CF/CM/CU48C	1.03	1.06	1.00
TM9V100C20MP12C	CF/CM/CU48D	1.03	1.06	1.00
TM9V100C20MP12C	CF/CM/CU60C	1.03	1.06	1.00
TM9V100C20MP12C	CF/CM64D	1.04	1.08	1.01
TM9V120D20MP11C	CF/CM/CU48D	1.04	1.09	1.01
TM9V120D20MP11C	CF/CM/CU60D	1.04	1.09	1.01
TM9V120D20MP11C	CF/CM42D	1.03	1.08	1.00
TM9V120D20MP11C	CF/CM64D	1.05	1.11	1.00
TM9V120D20MP12C	CF/CM/CU42D	1.03	1.08	1.00
TM9V120D20MP12C	CF/CM/CU48D	1.04	1.09	1.01
TM9V120D20MP12C	CF/CM/CU60D	1.04	1.09	1.01
TM9V120D20MP12C	CF/CM64D	1.05	1.11	1.00
TM9Y080C16MP11	CF/CM/CU42C	1.01	1.03	0.99
TM9Y080C16MP11	CF/CM/CU48C	1.03	1.04	1.00
TM9Y080C16MP11	CF/CM/CU48D	1.03	1.04	1.00
TM9Y080C16MP11	CF/CM/CU60C	1.01	1.01	0.99
TM9Y080C16MP11	CF/CM/CU60D	1.01	1.02	0.99
TM9Y080C16MP11	CF/CM42D	1.01	1.04	0.99
TM9Y080C16MP11	CF/CM64D	1.04	1.05	0.99
TM9Y100C16MP11	CF/CM/CU42C	1.00	1.03	0.98
TM9Y100C16MP11	CF/CM/CU42D	0.99	0.97	0.96
TM9Y100C16MP11	CF/CM/CU48C	1.00	1.01	0.98
TM9Y100C16MP11	CF/CM/CU48D	1.01	1.03	0.99
TM9Y100C16MP11	CF/CM/CU60C	1.01	1.03	0.99
TM9Y100C16MP11	CF/CM/CU60D	1.01	1.05	0.99
TM9Y100C16MP11	CF/CM42D	0.99	0.97	0.96
TM9Y100C16MP11	CF/CM64D	1.03	1.04	0.98
TM9Y100C20MP11	CF/CM/CU42C	1.01	1.06	0.99
TM9Y100C20MP11	CF/CM/CU42D	0.99	0.98	0.96
TM9Y100C20MP11	CF/CM/CU48C	1.03	1.06	1.00
TM9Y100C20MP11	CF/CM/CU48D	1.03	1.07	1.00
TM9Y100C20MP11	CF/CM/CU60C	1.03	1.07	0.98
TM9Y100C20MP11	CF/CM/CU60D	0.99	0.99	0.94
TM9Y100C20MP11	CF/CM42D	0.99	0.98	0.96
TM9Y100C20MP11	CF/CM64D	1.05	1.10	1.00

FURNACE MULTIPLIERS- 3.5 TON (Continued)

Furnaces	Coil	T.C.	S.C.	KW
TM9Y120D20MP11	CF/CM/CU42D	1.00	1.02	0.96
TM9Y120D20MP11	CF/CM/CU48D	1.00	1.01	0.96
TM9Y120D20MP11	CF/CM/CU60D	1.05	1.13	1.00
TM9Y120D20MP11	CF/CM42D	1.00	1.02	0.96
TM9Y120D20MP11	CF/CM64D	1.05	1.11	1.00
TMLV080C16MP12C	CF/CM/CU42C	1.00	1.03	0.98
TMLV080C16MP12C	CF/CM/CU42D	1.00	1.03	0.96
TMLV080C16MP12C	CF/CM/CU48C	1.03	1.07	1.00
TMLV080C16MP12C	CF/CM/CU48D	1.03	1.07	1.00
TMLV080C16MP12C	CF/CM/CU60C	1.01	1.03	0.99
TMLV080C16MP12C	CF/CM/CU60D	1.04	1.11	0.97
TMLV080C16MP12C	CF/CM64D	1.05	1.10	1.02
TMLV100C16MP12C	CF/CM/CU42C	1.00	1.03	0.98
TMLV100C16MP12C	CF/CM/CU42D	1.00	1.03	0.96
TMLV100C16MP12C	CF/CM/CU48C	1.03	1.07	1.00
TMLV100C16MP12C	CF/CM/CU48D	1.03	1.07	1.00
TMLV100C16MP12C	CF/CM/CU60C	1.01	1.03	0.99
TMLV100C16MP12C	CF/CM/CU60D	1.04	1.11	0.97
TMLV100C16MP12C	CF/CM64D	1.05	1.10	1.02
TMLV100C20MP12C	CF/CM/CU42C	1.01	1.05	0.99
TMLV100C20MP12C	CF/CM/CU42D	1.01	1.05	0.95
TMLV100C20MP12C	CF/CM/CU48C	1.03	1.05	1.00
TMLV100C20MP12C	CF/CM/CU48D	1.04	1.09	0.97
TMLV100C20MP12C	CF/CM/CU60C	1.05	1.12	1.02
TMLV100C20MP12C	CF/CM/CU60D	1.05	1.13	1.02
TMLV100C20MP12C	CF/CM64D	1.05	1.10	1.00
TMLV120C20MP12C	CF/CM/CU42C	1.01	1.05	0.99
TMLV120C20MP12C	CF/CM/CU42D	1.01	1.05	0.95
TMLV120C20MP12C	CF/CM/CU48C	1.03	1.05	1.00
TMLV120C20MP12C	CF/CM/CU48D	1.04	1.09	0.97
TMLV120C20MP12C	CF/CM/CU60C	1.05	1.12	1.02
TMLV120C20MP12C	CF/CM/CU60D	1.05	1.13	1.02
TMLV120C20MP12C	CF/CM64D	1.05	1.10	1.00
TMLX080B12MP11	CF42B	1.00	0.98	0.98
TMLX080C16MP11	CF/CM/CU42C	1.03	1.09	1.00
TMLX080C16MP11	CF/CM/CU42D	0.99	0.97	0.96
TMLX080C16MP11	CF/CM/CU48C	1.03	1.07	1.00
TMLX080C16MP11	CF/CM/CU48D	1.04	1.09	1.01
TMLX080C16MP11	CF/CM/CU60C	1.04	1.09	1.01
TMLX080C16MP11	CF/CM/CU60D	1.04	1.10	1.01
TMLX080C16MP11	CF/CM42D	0.99	0.97	0.96
TMLX080C16MP11	CF/CM64D	1.05	1.10	1.02
TMLX100C16MP11	CF/CM/CU42C	1.03	1.09	1.00
TMLX100C16MP11	CF/CM/CU42D	0.99	0.97	0.96
TMLX100C16MP11	CF/CM/CU48C	1.03	1.07	1.00
TMLX100C16MP11	CF/CM/CU48D	1.04	1.09	1.01
TMLX100C16MP11	CF/CM/CU60C	1.04	1.09	1.01
TMLX100C16MP11	CF/CM/CU60D	1.04	1.10	1.01
TMLX100C16MP11	CF/CM42D	0.99	0.97	0.96
TMLX100C16MP11	CF/CM64D	1.05	1.10	1.02
TMLX100C20MP11	CF/CM/CU42C	1.03	1.08	1.00
TMLX100C20MP11	CF/CM/CU42D	1.00	1.02	0.96
TMLX100C20MP11	CF/CM/CU48C	1.04	1.09	1.01
TMLX100C20MP11	CF/CM/CU48D	1.04	1.10	0.99
TMLX100C20MP11	CF/CM/CU60C	1.04	1.09	0.99
TMLX100C20MP11	CF/CM/CU60D	1.05	1.13	1.00

FURNACE MULTIPLIERS- 3.5 TON (Continued)

Furnaces	Coil	T.C.	S.C.	KW
TMLX100C20MP11	CF/CM42D	1.00	1.02	0.96
TMLX100C20MP11	CF/CM64D	1.05	1.11	1.00
TMLX120C20MP11	CF/CM/CU42C	1.03	1.08	1.00
TMLX120C20MP11	CF/CM/CU42D	1.00	1.02	0.96
TMLX120C20MP11	CF/CM/CU48C	1.04	1.09	1.01
TMLX120C20MP11	CF/CM/CU48D	1.04	1.10	0.99
TMLX120C20MP11	CF/CM/CU60C	1.04	1.09	0.99
TMLX120C20MP11	CF/CM/CU60D	1.05	1.13	1.00
TMLX120C20MP11	CF/CM42D	1.00	1.02	0.96
TMLX120C20MP11	CF/CM64D	1.05	1.11	1.00
TP9C080B12MP12C	CF42B	0.98	0.95	0.97
TP9C080B12MP13C	CF42B	0.98	0.95	0.97
TP9C080C16MP13C	CF/CM/CU42C	1.01	1.01	0.99
TP9C080C16MP13C	CF/CM/CU48C	1.01	1.01	0.99
TP9C080C16MP13C	CF/CM/CU48D	1.01	1.01	0.99
TP9C080C16MP13C	CF/CM/CU60C	1.01	1.00	0.99
TP9C080C16MP13C	CF/CM/CU60D	1.01	1.01	0.99
TP9C080C16MP13C	CF/CM42D	1.01	1.01	0.99
TP9C080C16MP13C	CF/CM64D	1.04	1.03	1.01
TP9C100C16MP12C	CF/CM/CU42C	1.01	1.05	0.99
TP9C100C16MP12C	CF/CM/CU48C	1.01	1.03	0.99
TP9C100C16MP12C	CF/CM/CU48D	1.01	1.03	0.99
TP9C100C16MP12C	CF/CM/CU60C	1.01	1.03	0.99
TP9C100C16MP12C	CF/CM/CU60D	1.01	1.04	0.99
TP9C100C16MP12C	CF/CM64D	1.03	1.05	1.00
TP9C100C16MP13C	CF/CM/CU42C	1.01	1.05	0.99
TP9C100C16MP13C	CF/CM/CU42D	1.00	1.03	0.96
TP9C100C16MP13C	CF/CM/CU48C	1.01	1.03	0.99
TP9C100C16MP13C	CF/CM/CU48D	1.01	1.03	0.99
TP9C100C16MP13C	CF/CM/CU60C	1.01	1.03	0.99
TP9C100C16MP13C	CF/CM/CU60D	1.01	1.04	0.99
TP9C100C16MP13C	CF/CM64D	1.03	1.05	1.00
TP9C100C20MP12C	CF/CM/CU42C	0.99	0.99	0.96
TP9C100C20MP12C	CF/CM/CU48C	1.03	1.06	1.00
TP9C100C20MP12C	CF/CM/CU48D	1.03	1.06	1.00
TP9C100C20MP12C	CF/CM/CU60C	1.03	1.06	1.00
TP9C100C20MP12C	CF/CM/CU60D	1.03	1.06	1.00
TP9C100C20MP12C	CF/CM64D	1.04	1.08	1.01
TP9C100C20MP13C	CF/CM/CU42C	0.99	0.99	0.96
TP9C100C20MP13C	CF/CM/CU42D	1.01	1.06	0.97
TP9C100C20MP13C	CF/CM/CU48C	1.03	1.06	1.00
TP9C100C20MP13C	CF/CM/CU48D	1.03	1.06	1.00
TP9C100C20MP13C	CF/CM/CU60C	1.03	1.06	1.00
TP9C100C20MP13C	CF/CM/CU60D	1.03	1.06	1.00
TP9C100C20MP13C	CF/CM64D	1.04	1.08	1.01
TP9C120D20MP12C	CF/CM42D	1.03	1.08	1.00
TP9C120D20MP13C	CF/CM/CU42D	1.03	1.08	1.00
TP9C120D20MP13C	CF/CM/CU48D	1.04	1.09	1.01
TP9C120D20MP13C	CF/CM/CU60D	1.04	1.09	1.01
TP9C120D20MP13C	CF/CM64D	1.05	1.11	1.00
TPLC080C16MP12C	CF/CM/CU42C	1.00	1.03	0.98
TPLC080C16MP12C	CF/CM/CU48C	1.03	1.07	1.00
TPLC080C16MP12C	CF/CM/CU48D	1.03	1.07	1.00
TPLC080C16MP12C	CF/CM/CU60C	1.01	1.03	0.99
TPLC080C16MP12C	CF/CM64D	1.05	1.10	1.02
TPLC080C16MP13C	CF/CM/CU42C	1.00	1.03	0.98

FURNACE MULTIPLIERS- 3.5 TON (Continued)

Furnaces	Coil	T.C.	S.C.	KW
TPLC080C16MP13C	CF/CM/CU42D	1.00	1.03	0.96
TPLC080C16MP13C	CF/CM/CU48C	1.03	1.07	1.00
TPLC080C16MP13C	CF/CM/CU48D	1.03	1.07	1.00
TPLC080C16MP13C	CF/CM/CU60C	1.01	1.03	0.99
TPLC080C16MP13C	CF/CM/CU60D	1.04	1.11	0.97
TPLC080C16MP13C	CF/CM64D	1.05	1.10	1.02
TPLC100C16MP12C	CF/CM/CU42C	1.00	1.03	0.98
TPLC100C16MP12C	CF/CM/CU48C	1.03	1.07	1.00
TPLC100C16MP12C	CF/CM/CU48D	1.03	1.07	1.00
TPLC100C16MP12C	CF/CM/CU60C	1.01	1.03	0.99
TPLC100C16MP12C	CF/CM64D	1.05	1.10	1.02
TPLC100C16MP13C	CF/CM/CU42C	1.00	1.03	0.98
TPLC100C16MP13C	CF/CM/CU42D	1.00	1.03	0.96
TPLC100C16MP13C	CF/CM/CU48C	1.03	1.07	1.00
TPLC100C16MP13C	CF/CM/CU48D	1.03	1.07	1.00
TPLC100C16MP13C	CF/CM/CU60C	1.01	1.03	0.99
TPLC100C16MP13C	CF/CM/CU60D	1.04	1.11	0.97
TPLC100C16MP13C	CF/CM64D	1.05	1.10	1.02
TPLC100C20MP13C	CF/CM/CU42C	1.01	1.05	0.99
TPLC100C20MP13C	CF/CM/CU42D	1.01	1.05	0.95
TPLC100C20MP13C	CF/CM/CU48C	1.03	1.05	1.00
TPLC100C20MP13C	CF/CM/CU48D	1.04	1.09	0.97
TPLC100C20MP13C	CF/CM/CU60C	1.05	1.12	1.02
TPLC100C20MP13C	CF/CM/CU60D	1.05	1.13	1.02
TPLC100C20MP13C	CF/CM64D	1.05	1.10	1.00
TPLC120C20MP13C	CF/CM/CU42C	1.01	1.05	0.99
TPLC120C20MP13C	CF/CM/CU42D	1.01	1.05	0.95
TPLC120C20MP13C	CF/CM/CU48C	1.03	1.05	1.00
TPLC120C20MP13C	CF/CM/CU48D	1.04	1.09	0.97
TPLC120C20MP13C	CF/CM/CU60C	1.05	1.12	1.02
TPLC120C20MP13C	CF/CM/CU60D	1.05	1.13	1.02
TPLC120C20MP13C	CF/CM64D	1.05	1.10	1.00
CP9C080B12MP12C	CF42B	0.98	0.95	0.97
CP9C080B12MP13C	CF42B	0.98	0.95	0.97
CP9C080C16MP13C	CF/CM/CU42C	1.01	1.01	0.99
CP9C080C16MP13C	CF/CM/CU48C	1.01	1.01	0.99
CP9C080C16MP13C	CF/CM/CU48D	1.01	1.01	0.99
CP9C080C16MP13C	CF/CM/CU60C	1.01	1.00	0.99
CP9C080C16MP13C	CF/CM/CU60D	1.01	1.01	0.99
CP9C080C16MP13C	CF/CM42D	1.01	1.01	0.99
CP9C080C16MP13C	CF/CM64D	1.04	1.03	1.01
CP9C100C16MP12C	CF/CM/CU42C	1.01	1.05	0.99
CP9C100C16MP12C	CF/CM/CU48C	1.01	1.03	0.99
CP9C100C16MP12C	CF/CM/CU48D	1.01	1.03	0.99
CP9C100C16MP12C	CF/CM/CU60C	1.01	1.03	0.99
CP9C100C16MP12C	CF/CM/CU60D	1.01	1.04	0.99
CP9C100C16MP12C	CF/CM64D	1.03	1.05	1.00
CP9C100C16MP13C	CF/CM/CU42C	1.01	1.05	0.99
CP9C100C16MP13C	CF/CM/CU42D	1.00	1.03	0.96
CP9C100C16MP13C	CF/CM/CU48C	1.01	1.03	0.99
CP9C100C16MP13C	CF/CM/CU48D	1.01	1.03	0.99
CP9C100C16MP13C	CF/CM/CU60C	1.01	1.04	0.99
CP9C100C16MP13C	CF/CM64D	1.03	1.05	1.00
CP9C100C20MP12C	CF/CM/CU42C	0.99	0.99	0.96
CP9C100C20MP12C	CF/CM/CU48C	1.03	1.06	1.00

FURNACE MULTIPLIERS- 3.5 TON (Continued)

Furnaces	Coil	T.C.	S.C.	KW
CP9C100C20MP12C	CF/CM/CU48D	1.03	1.06	1.00
CP9C100C20MP12C	CF/CM/CU60C	1.03	1.06	1.00
CP9C100C20MP12C	CF/CM/CU60D	1.03	1.06	1.00
CP9C100C20MP12C	CF/CM64D	1.04	1.08	1.01
CP9C100C20MP13C	CF/CM/CU42C	0.99	0.99	0.96
CP9C100C20MP13C	CF/CM/CU42D	1.01	1.06	0.97
CP9C100C20MP13C	CF/CM/CU48C	1.03	1.06	1.00
CP9C100C20MP13C	CF/CM/CU48D	1.03	1.06	1.00
CP9C100C20MP13C	CF/CM/CU60C	1.03	1.06	1.00
CP9C100C20MP13C	CF/CM/CU60D	1.03	1.06	1.00
CP9C100C20MP13C	CF/CM64D	1.04	1.08	1.01
CP9C120D20MP12C	CF/CM/CU48D	1.04	1.09	1.01
CP9C120D20MP12C	CF/CM/CU60D	1.04	1.09	1.01
CP9C120D20MP12C	CF/CM42D	1.03	1.08	1.00
CP9C120D20MP12C	CF/CM64D	1.05	1.11	1.00
CP9C120D20MP13C	CF/CM/CU42D	1.03	1.08	1.00
CP9C120D20MP13C	CF/CM/CU48D	1.04	1.09	1.01
CP9C120D20MP13C	CF/CM/CU60D	1.04	1.09	1.01
CP9C120D20MP13C	CF/CM64D	1.05	1.11	1.00
CPLC080C16MP12C	CF/CM/CU42C	1.00	1.03	0.98
CPLC080C16MP12C	CF/CM/CU48C	1.03	1.07	1.00
CPLC080C16MP12C	CF/CM/CU48D	1.03	1.07	1.00
CPLC080C16MP12C	CF/CM/CU60C	1.01	1.03	0.99
CPLC080C16MP12C	CF/CM64D	1.05	1.10	1.02
CPLC080C16MP13C	CF/CM/CU42C	1.00	1.03	0.98
CPLC080C16MP13C	CF/CM/CU42D	1.00	1.03	0.96
CPLC080C16MP13C	CF/CM/CU48C	1.03	1.07	1.00
CPLC080C16MP13C	CF/CM/CU48D	1.03	1.07	1.00
CPLC080C16MP13C	CF/CM/CU60C	1.01	1.03	0.99
CPLC080C16MP13C	CF/CM/CU60D	1.04	1.11	0.97
CPLC080C16MP13C	CF/CM64D	1.05	1.10	1.02
CPLC100C16MP12C	CF/CM/CU42C	1.00	1.03	0.98
CPLC100C16MP12C	CF/CM/CU48C	1.03	1.07	1.00
CPLC100C16MP12C	CF/CM/CU48D	1.03	1.07	1.00
CPLC100C16MP12C	CF/CM/CU60C	1.01	1.03	0.99

FURNACE MULTIPLIERS- 3.5 TON (Continued)

Furnaces	Coil	T.C.	S.C.	KW
CPLC100C16MP12C	CF/CM64D	1.05	1.10	1.02
CPLC100C16MP13C	CF/CM/CU42C	1.00	1.03	0.98
CPLC100C16MP13C	CF/CM/CU42D	1.00	1.03	0.96
CPLC100C16MP13C	CF/CM/CU48C	1.03	1.07	1.00
CPLC100C16MP13C	CF/CM/CU48D	1.03	1.07	1.00
CPLC100C16MP13C	CF/CM/CU60C	1.01	1.03	0.99
CPLC100C16MP13C	CF/CM/CU60D	1.04	1.11	0.97
CPLC100C16MP13C	CF/CM64D	1.05	1.10	1.02
CPLC100C20MP12C	CF/CM/CU42C	1.01	1.05	0.99
CPLC100C20MP12C	CF/CM/CU48C	1.03	1.05	1.00
CPLC100C20MP12C	CF/CM/CU60C	1.05	1.12	1.02
CPLC100C20MP12C	CF/CM/CU60D	1.05	1.13	1.02
CPLC100C20MP12C	CF/CM64D	1.05	1.10	1.00
CPLC100C20MP13C	CF/CM/CU42C	1.01	1.05	0.99
CPLC100C20MP13C	CF/CM/CU42D	1.01	1.05	0.95
CPLC100C20MP13C	CF/CM/CU48C	1.03	1.05	1.00
CPLC100C20MP13C	CF/CM/CU48D	1.04	1.09	0.97
CPLC100C20MP13C	CF/CM/CU60C	1.05	1.12	1.02
CPLC100C20MP13C	CF/CM/CU60D	1.05	1.13	1.02
CPLC100C20MP13C	CF/CM64D	1.05	1.10	1.00
CPLC120C20MP12C	CF/CM/CU42C	1.01	1.05	0.99
CPLC120C20MP12C	CF/CM/CU48C	1.03	1.05	1.00
CPLC120C20MP12C	CF/CM/CU60C	1.05	1.12	1.02
CPLC120C20MP12C	CF/CM/CU60D	1.05	1.13	1.02
CPLC120C20MP12C	CF/CM64D	1.05	1.10	1.00
CPLC120C20MP13C	CF/CM/CU42C	1.01	1.05	0.99
CPLC120C20MP13C	CF/CM/CU42D	1.01	1.05	0.95
CPLC120C20MP13C	CF/CM/CU48C	1.03	1.05	1.00
CPLC120C20MP13C	CF/CM/CU48D	1.04	1.09	0.97
CPLC120C20MP13C	CF/CM/CU60C	1.05	1.12	1.02
CPLC120C20MP13C	CF/CM/CU60D	1.05	1.13	1.02
CPLC120C20MP13C	CF/CM64D	1.05	1.10	1.00

PERFORMANCE DATA - 4 TON

CONDENSER-ONLY DATA (OUTDOOR UNIT)																		
MODEL	SATURATED SUCTION @ COMPRESSOR		Outdoor Ambient Temperature															
			55 °F		65 °F		75 °F		85 °F		95 °F		105 °F		115 °F		125 °F	
	T (°F)	P (PSIG)	MBH	KW	MBH	KW	MBH	KW	MBH	KW	MBH	KW	MBH	KW	MBH	KW	MBH	KW
TW4B4821S	35	107	47.8	2.16	45.5	2.42	43.2	2.72	40.8	3.05	38.3	3.44	35.7	3.90	32.8	4.41	29.8	4.99
	40	118	52.5	2.16	50.0	2.42	47.5	2.71	44.9	3.05	42.3	3.43	39.4	3.89	36.4	4.40	33.1	4.98
	45	130	57.6	2.17	54.8	2.42	52.1	2.71	49.4	3.04	46.5	3.42	43.4	3.88	40.2	4.40	36.7	4.96
	50	142	63.0	2.18	60.0	2.43	57.0	2.72	54.0	3.06	50.9	3.42	47.7	3.87	44.1	4.39	40.5	4.94
	55	156	68.7	2.19	65.4	2.44	62.2	2.73	58.9	3.07	55.6	3.44	52.2	3.88	48.4	4.39	44.5	4.93

Notes:

- For Outdoor Unit (Condenser) performance only. Data does not include the effects of air handler power or heat.
- Performance based on 15°F subcooling and 15°F superheat at the Outdoor Unit base valves.
 - Increase capacity by 1% for each 2°F increase in subcooling.
 - Decrease capacity by 1% for each 2°F decrease in subcooling.
- Maximum recommended condensing temperature is 140°F.

COOLING PERFORMANCE DATA																
OUTDOOR UNIT MODEL NO.		TW4B4821S														
INDOOR COIL MODEL NO.		CF48CXA1														
AIR TEMP. ENTERING OUTDOOR UNIT (°F)	ID CFM	1400					1600					1800				
	ID DB (°F)	80	80	75	80	80	80	80	75	80	80	80	80	75	80	80
	ID WB (°F)	57	62	62	67	72	57	62	62	67	72	57	62	62	67	72
55	T.C.	44.9	47.6	47.5	49.3	49.9	45.1	47.8	47.5	49.4	49.9	45.3	48.0	47.6	49.5	49.9
	S.C.	44.1	37.8	32.4	30.3	23.1	44.5	38.9	33.1	30.8	23.3	44.9	39.9	33.9	31.3	23.5
	KW	2.62	2.66	2.66	2.68	2.70	2.70	2.74	2.74	2.76	2.78	2.77	2.81	2.81	2.84	2.86
65	T.C.	44.6	47.3	47.0	49.6	50.9	45.4	47.6	47.4	49.9	51.0	46.2	48.0	47.7	50.1	51.1
	S.C.	43.9	39.2	33.1	31.4	23.8	44.8	40.6	34.3	32.2	24.1	45.6	42.1	35.5	33.1	24.5
	KW	2.89	2.92	2.92	2.95	2.97	2.97	3.00	3.00	3.03	3.05	3.05	3.07	3.07	3.10	3.13
75	T.C.	44.4	46.9	46.6	49.9	51.9	45.7	47.4	47.2	50.3	52.1	47.1	47.9	47.8	50.7	52.3
	S.C.	43.8	40.5	33.9	32.5	24.5	45.1	42.4	35.5	33.7	25.0	46.4	44.3	37.2	34.8	25.4
	KW	3.17	3.18	3.18	3.22	3.23	3.24	3.26	3.26	3.29	3.31	3.32	3.33	3.33	3.36	3.39
85	T.C.	42.6	44.8	44.6	48.4	51.2	44.0	45.5	45.3	48.9	51.5	45.5	46.2	46.0	49.4	51.8
	S.C.	42.0	39.2	32.9	32.3	24.6	43.4	41.4	34.8	33.9	25.3	44.8	43.7	36.7	35.5	26.1
	KW	3.56	3.59	3.57	3.59	3.61	3.63	3.66	3.64	3.67	3.68	3.70	3.73	3.71	3.74	3.76
95	T.C.	40.8	42.7	42.6	46.9	50.4	42.3	43.5	43.4	47.5	50.9	43.9	44.4	44.2	48.1	51.3
	S.C.	40.2	37.8	32.0	32.2	24.7	41.7	40.5	34.1	34.2	25.7	43.3	43.2	36.2	36.2	26.7
	KW	3.96	3.99	3.96	3.97	3.98	4.02	4.05	4.03	4.04	4.05	4.08	4.12	4.10	4.12	4.13
105	T.C.	38.9	40.2	40.1	44.1	47.8	40.3	41.1	40.8	44.6	48.2	41.7	42.0	41.5	45.2	48.7
	S.C.	38.5	36.6	30.9	31.0	23.8	39.8	38.9	32.9	33.0	24.8	41.2	41.2	35.0	35.0	25.8
	KW	4.68	4.73	4.73	4.68	4.64	4.73	4.77	4.79	4.74	4.71	4.78	4.82	4.84	4.80	4.78
115	T.C.	37.2	37.8	37.6	41.4	45.2	38.4	38.8	38.3	41.9	45.6	39.7	39.8	38.9	42.3	46.1
	S.C.	36.9	35.5	29.9	29.9	22.9	38.0	37.3	31.8	31.8	23.9	39.1	39.2	33.7	33.8	24.9
	KW	5.38	5.44	5.47	5.37	5.27	5.42	5.47	5.52	5.41	5.34	5.45	5.50	5.56	5.46	5.41
125	T.C.	35.4	35.4	35.2	38.7	42.6	36.5	36.4	35.7	39.1	43.0	37.6	37.5	36.3	39.5	43.5
	S.C.	35.2	34.3	28.9	28.8	22.0	36.1	35.8	30.7	30.7	23.0	37.0	37.2	32.5	32.6	24.0
	KW	6.09	6.16	6.21	6.07	5.91	6.10	6.17	6.25	6.09	5.97	6.12	6.18	6.29	6.12	6.04

NOTE: ALL CAPACITIES INCLUDE INDOOR FAN HEAT. KW VALUES ARE FOR THE SYSTEM (OUTDOOR + INDOOR).

Green shaded cells are ACCA (TVA) conditions.

Blue shaded cells are AHRI conditions.

Multipliers for determining the performance with other indoor sections.

NOTE: For dry bulb temperatures different than those listed (between 73-87 °F), sensible capacity increases by 1060 BTUH per 1000 CFM per degree above the listed temperature and decreases by 1060 BTUH per 1000 CFM per degree below the listed temperature.

COIL MULTIPLIERS- 4 TON

Air Handler	Coil	T.C.	S.C.	KW
-	CF/CM/CU48C	1.00	1.00	1.00
-	CF/CM/CU48D	1.00	1.00	1.00
-	CF/CM/CU60C	1.01	1.05	0.97
-	CF/CM/CU60D	1.01	1.05	0.97
-	CF/CM64D	1.01	1.05	0.97
AE48CX21	-	1.01	1.01	0.93
AE48DX21	-	1.01	1.01	0.91
AE60CX21	-	1.01	1.02	0.93
AE60DX21	-	1.01	1.01	0.90
AP48CX21	-	1.01	0.98	0.99
AP48DX21	-	1.00	0.99	1.00
AP60CX21	-	1.01	1.07	0.99
AP60DX21	-	1.01	1.05	0.99
AVC48CX21	-	1.01	0.99	0.93
AVC48DX21	-	1.01	1.01	0.91
AVC60CX21	-	1.01	1.01	0.91
AVC60DX21	-	1.01	1.02	0.91
ME14DN21	CF/CM60D	1.01	1.01	0.91
ME14DN21	CF/CM64D	1.01	0.99	0.91
ME16CN21	CF/CM48C	1.01	1.04	0.91
ME16CN21	CF/CM60C	1.01	1.02	0.91
ME20DN21	CF/CM48D	1.01	1.04	0.91
ME20DN21	CF/CM60D	1.01	1.01	0.93
ME20DN21	CF/CM64D	1.01	1.02	0.91
MVC14DN21	CF/CM48D	1.01	0.98	0.93
MVC14DN21	CF/CM60D	1.01	0.98	0.93
MVC14DN21	CF/CM64D	1.01	0.98	0.91
MVC16CN21	CF/CM48C	1.01	1.01	0.93
MVC16CN21	CF/CM60C	1.01	1.08	0.90
MVC20DN21	CF/CM48D	1.01	1.02	0.93
MVC20DN21	CF/CM60D	1.01	1.04	0.91
MVC20DN21	CF/CM64D	1.01	0.99	0.91

FURNACE MULTIPLIERS- 4 TON

Furnaces	Coil	T.C.	S.C.	KW
TL8E080C16UH11	CF/CM/CU48C	1.01	1.02	0.95
TL8E080C16UH11	CF/CM/CU48D	1.01	1.02	0.97
TL8E080C16UH11	CF/CM/CU60C	1.01	1.02	0.97
TL8E080C16UH11	CF/CM/CU60D	1.01	1.03	0.95
TL8E080C16UH11	CF/CM64D	1.01	1.02	0.95
TL8E100C20UH11	CF/CM/CU48C	1.01	1.02	0.95
TL8E100C20UH11	CF/CM/CU48D	1.01	1.03	0.95
TL8E100C20UH11	CF/CM/CU60C	1.01	1.02	0.95
TL8E100C20UH11	CF/CM/CU60D	1.01	1.04	0.95
TL8E100C20UH11	CF/CM64D	1.01	1.03	0.93
TL9E080C16UH11	CF/CM/CU48C	1.01	1.02	0.97
TL9E080C16UH11	CF/CM/CU48D	1.01	1.02	0.97
TL9E080C16UH11	CF/CM/CU60C	1.01	1.02	0.97
TL9E080C16UH11	CF/CM/CU60D	1.01	1.04	0.97
TL9E080C16UH11	CF/CM64D	1.01	1.03	0.95
TL9E100C20UH11	CF/CM/CU48C	1.01	1.02	0.95
TL9E100C20UH11	CF/CM/CU48D	1.01	1.03	0.95

FURNACE MULTIPLIERS- 4 TON (Continued)

Furnaces	Coil	T.C.	S.C.	KW
TL9E100C20UH11	CF/CM/CU60C	1.01	1.02	0.95
TL9E100C20UH11	CF/CM/CU60D	1.01	1.04	0.95
TL9E100C20UH11	CF/CM64D	1.01	1.03	0.93
TM8E080B12MP11	CF/CM/CU48C	1.01	1.01	0.99
TM8E080C16MP11	CF/CM/CU48C	1.00	1.02	1.00
TM8E080C16MP11	CF/CM/CU48D	1.01	1.04	1.01
TM8E080C16MP11	CF/CM/CU60C	1.01	1.06	0.97
TM8E080C16MP11	CF/CM/CU60D	1.01	1.08	0.97
TM8E080C16MP11	CF/CM64D	1.01	1.07	0.97
TM8E080C20MP11	CF/CM/CU48C	1.01	1.04	0.95
TM8E080C20MP11	CF/CM/CU48D	1.01	1.04	0.95
TM8E080C20MP11	CF/CM/CU60C	1.01	1.04	0.95
TM8E080C20MP11	CF/CM/CU60D	1.01	1.05	0.95
TM8E080C20MP11	CF/CM64D	1.01	1.04	0.93
TM8E100C16MP11	CF/CM/CU48C	1.01	0.99	0.95
TM8E100C16MP11	CF/CM/CU48D	1.01	0.99	0.95
TM8E100C16MP11	CF/CM/CU60C	1.01	1.06	0.97
TM8E100C16MP11	CF/CM/CU60D	1.01	1.00	0.95
TM8E100C16MP11	CF/CM64D	1.01	1.00	0.93
TM8E100C20MP11	CF/CM/CU48C	1.01	1.03	0.95
TM8E100C20MP11	CF/CM/CU48D	1.01	1.04	0.95
TM8E100C20MP11	CF/CM/CU60C	1.01	1.02	0.95
TM8E100C20MP11	CF/CM/CU60D	1.01	1.04	0.95
TM8E100C20MP11	CF/CM64D	1.01	1.03	0.93
TM8E120C16MP11	CF/CM/CU48C	1.01	0.99	0.95
TM8E120C16MP11	CF/CM/CU48D	1.01	0.99	0.95
TM8E120C16MP11	CF/CM/CU60C	1.01	0.99	0.95
TM8E120C16MP11	CF/CM/CU60D	1.01	1.01	0.95
TM8E120C16MP11	CF/CM64D	1.01	1.00	0.93
TM8E120C20MP11	CF/CM/CU48C	1.01	1.03	0.95
TM8E120C20MP11	CF/CM/CU48D	1.01	1.04	0.95
TM8E120C20MP11	CF/CM/CU60C	1.01	1.02	0.95
TM8E120C20MP11	CF/CM/CU60D	1.01	1.01	0.93
TM8E120C20MP11	CF/CM64D	1.01	1.03	0.93
TM8E120C20MP11	CF/CM64D	1.01	1.03	0.93
TM8E120C20MP11	CF/CM/CU48D	1.01	1.03	0.93
TM8E120C20MP11	CF/CM/CU60D	1.01	1.04	0.93
TM8E130D20MP11	CF/CM64D	1.01	1.03	0.91
TM8V080C16MP11C	CF/CM/CU48C	1.01	0.98	0.95
TM8V080C16MP11C	CF/CM/CU48D	1.01	0.98	0.95
TM8V080C16MP11C	CF/CM/CU60C	1.01	0.98	0.93
TM8V080C16MP11C	CF/CM/CU60D	1.01	0.98	0.93
TM8V080C16MP11C	CF/CM64D	1.01	1.01	0.93
TM8V080C16MP12C	CF/CM/CU48C	0.99	1.01	0.93
TM8V080C16MP12C	CF/CM/CU48D	1.01	1.03	0.95
TM8V080C16MP12C	CF/CM/CU60C	0.99	1.02	0.93
TM8V080C16MP12C	CF/CM/CU60D	0.99	1.02	0.91
TM8V080C16MP12C	CF/CM64D	1.01	1.04	0.93
TM8V100C16MP11C	CF/CM/CU48C	1.01	0.98	0.95
TM8V100C16MP11C	CF/CM/CU48D	1.01	0.98	0.95
TM8V100C16MP11C	CF/CM/CU60C	1.01	0.98	0.93
TM8V100C16MP11C	CF/CM/CU60D	1.01	0.98	0.93
TM8V100C16MP11C	CF/CM64D	1.01	1.01	0.93
TM8V100C16MP12C	CF/CM/CU48C	0.99	1.01	0.93
TM8V100C16MP12C	CF/CM/CU48D	1.01	1.03	0.95
TM8V100C16MP12C	CF/CM/CU60C	0.99	1.02	0.93

FURNACE MULTIPLIERS- 4 TON (Continued)

Furnaces	Coil	T.C.	S.C.	KW
TM8V100C16MP12C	CF/CM/CU60D	0.99	1.02	0.91
TM8V100C16MP12C	CF/CM64D	1.01	1.04	0.93
TM8V100C20MP11C	CF/CM/CU48C	1.01	0.98	0.95
TM8V100C20MP11C	CF/CM/CU48D	1.01	1.03	0.93
TM8V100C20MP11C	CF/CM/CU60C	1.01	1.01	0.93
TM8V100C20MP11C	CF/CM/CU60D	1.01	0.99	0.95
TM8V100C20MP11C	CF/CM64D	1.01	1.02	0.93
TM8V100C20MP12C	CF/CM/CU48C	0.99	1.01	0.93
TM8V100C20MP12C	CF/CM/CU48D	1.01	1.01	0.93
TM8V100C20MP12C	CF/CM/CU60C	1.00	1.01	0.92
TM8V100C20MP12C	CF/CM/CU60D	1.01	1.05	0.95
TM8V100C20MP12C	CF/CM64D	1.00	1.02	0.94
TM8V120C20MP12C	CF/CM/CU48C	0.99	1.01	0.93
TM8V120C20MP12C	CF/CM/CU48D	1.01	1.01	0.93
TM8V120C20MP12C	CF/CM/CU60C	1.00	1.01	0.92
TM8V120C20MP12C	CF/CM/CU60D	1.01	1.05	0.95
TM8V120C20MP12C	CF/CM64D	1.00	1.02	0.94
TM8X080C16MP11	CF/CM/CU48C	1.01	1.02	0.95
TM8X080C16MP11	CF/CM/CU48D	1.01	1.00	0.95
TM8X080C16MP11	CF/CM/CU60C	1.01	1.01	0.95
TM8X080C16MP11	CF/CM/CU60D	1.01	1.01	0.93
TM8X080C16MP11	CF/CM64D	1.01	1.01	0.93
TM8X100C16MP11	CF/CM/CU48C	1.01	1.02	0.95
TM8X100C16MP11	CF/CM/CU48D	1.01	1.00	0.95
TM8X100C16MP11	CF/CM/CU60C	1.01	1.01	0.95
TM8X100C16MP11	CF/CM/CU60D	1.01	1.01	0.93
TM8X100C16MP11	CF/CM64D	1.01	1.01	0.93
TM8X100C20MP11	CF/CM/CU48C	1.01	1.01	0.93
TM8X100C20MP11	CF/CM/CU48D	1.01	0.98	0.91
TM8X100C20MP11	CF/CM/CU60C	1.01	1.03	0.93
TM8X100C20MP11	CF/CM/CU60D	1.01	1.03	0.91
TM8X100C20MP11	CF/CM64D	1.01	1.02	0.91
TM8X120C20MP11	CF/CM/CU48C	1.01	1.01	0.93
TM8X120C20MP11	CF/CM/CU48D	1.01	0.98	0.91
TM8X120C20MP11	CF/CM/CU60C	1.01	1.03	0.93
TM8X120C20MP11	CF/CM/CU60D	1.01	1.03	0.91
TM8X120C20MP11	CF/CM64D	1.01	1.02	0.91
TM8Y080C16MP11	CF/CM/CU48C	1.01	1.02	0.95
TM8Y080C16MP11	CF/CM/CU48D	1.01	1.00	0.95
TM8Y080C16MP11	CF/CM/CU60C	1.01	1.01	0.95
TM8Y080C16MP11	CF/CM/CU60D	1.01	1.01	0.93
TM8Y080C16MP11	CF/CM64D	1.01	1.01	0.93
TM8Y100C16MP11	CF/CM/CU48C	1.01	1.02	0.95
TM8Y100C16MP11	CF/CM/CU48D	1.01	1.00	0.95
TM8Y100C16MP11	CF/CM/CU60C	1.01	1.01	0.95
TM8Y100C16MP11	CF/CM/CU60D	1.01	1.01	0.93
TM8Y100C16MP11	CF/CM64D	1.01	1.01	0.93
TM8Y100C20MP11	CF/CM/CU48C	1.01	1.01	0.93
TM8Y100C20MP11	CF/CM/CU48D	1.01	0.98	0.91
TM8Y100C20MP11	CF/CM/CU60C	1.01	1.03	0.93
TM8Y100C20MP11	CF/CM/CU60D	1.01	1.03	0.91
TM8Y100C20MP11	CF/CM64D	1.01	1.02	0.91
TM8Y120C20MP11	CF/CM/CU48C	1.01	1.01	0.93
TM8Y120C20MP11	CF/CM/CU48D	1.01	0.98	0.91
TM8Y120C20MP11	CF/CM/CU60C	1.01	1.03	0.93

FURNACE MULTIPLIERS- 4 TON (Continued)

Furnaces	Coil	T.C.	S.C.	KW
TM8Y120C20MP11	CF/CM/CU60D	1.01	1.03	0.91
TM8Y120C20MP11	CF/CM64D	1.01	1.02	0.91
TM9E080B12MP12	CF/CM/CU48C	1.01	1.01	0.99
TM9E080B12MP12	CF/CM/CU60C	1.00	0.99	1.00
TM9E080C16MP11	CF/CM/CU48D	1.01	0.98	0.95
TM9E080C16MP11	CF/CM/CU60C	1.01	0.99	0.95
TM9E080C16MP11	CF/CM/CU60D	1.01	0.99	0.95
TM9E080C16MP11	CF/CM64D	1.01	0.98	0.93
TM9E080C20MP12	CF/CM/CU48C	1.01	1.02	0.95
TM9E080C20MP12	CF/CM/CU48D	1.01	1.03	0.95
TM9E080C20MP12	CF/CM/CU60C	1.01	1.02	0.95
TM9E080C20MP12	CF/CM/CU60D	1.01	1.04	0.95
TM9E080C20MP12	CF/CM64D	1.01	1.03	0.93
TM9E100C16MP11	CF/CM/CU48C	1.01	0.98	0.95
TM9E100C16MP11	CF/CM/CU48D	1.01	0.98	0.95
TM9E100C16MP11	CF/CM/CU60C	1.01	0.99	0.95
TM9E100C16MP11	CF/CM/CU60D	1.01	0.99	0.95
TM9E100C16MP11	CF/CM64D	1.01	0.98	0.93
TM9E100C16MP12	CF/CM/CU60D	1.01	1.08	0.99
TM9E100C20MP11	CF/CM/CU48C	1.01	1.02	0.95
TM9E100C20MP11	CF/CM/CU48D	1.01	1.01	0.93
TM9E100C20MP11	CF/CM/CU60C	1.01	1.01	0.93
TM9E100C20MP11	CF/CM/CU60D	1.01	1.03	0.93
TM9E100C20MP11	CF/CM64D	1.01	1.01	0.93
TM9E100C20MP12	CF/CM/CU48C	1.01	1.02	0.95
TM9E100C20MP12	CF/CM/CU48D	1.01	1.03	0.95
TM9E100C20MP12	CF/CM/CU60C	1.01	1.02	0.95
TM9E100C20MP12	CF/CM/CU60D	1.01	1.04	0.95
TM9E100C20MP12	CF/CM64D	1.01	1.03	0.93
TM9E120D20MP11	CF/CM/CU48D	1.01	1.01	0.93
TM9E120D20MP11	CF/CM/CU60D	1.01	1.02	0.93
TM9E120D20MP11	CF/CM64D	1.01	1.01	0.93
TM9E120D20MP12	CF/CM/CU48D	1.01	1.04	0.95
TM9E120D20MP12	CF/CM/CU60D	1.01	1.04	0.95
TM9E120D20MP12	CF/CM64D	1.01	1.04	0.93
TM9V080C16MP11C	CF/CM/CU48C	0.99	0.97	0.93
TM9V080C16MP11C	CF/CM/CU48D	0.99	0.96	0.91
TM9V080C16MP11C	CF/CM/CU60C	0.99	0.97	0.93
TM9V080C16MP11C	CF/CM/CU60D	0.99	0.97	0.93
TM9V080C16MP11C	CF/CM64D	0.99	0.98	0.91
TM9V080C16MP12C	CF/CM/CU48C	0.99	0.97	0.93
TM9V080C16MP12C	CF/CM/CU48D	0.99	0.96	0.91
TM9V080C16MP12C	CF/CM/CU60C	0.99	0.97	0.93
TM9V080C16MP12C	CF/CM/CU60D	0.99	0.97	0.93
TM9V080C16MP12C	CF/CM64D	0.99	0.98	0.91
TM9V100C16MP11C	CF/CM/CU48C	1.01	1.01	0.95
TM9V100C16MP11C	CF/CM/CU48D	1.01	1.01	0.91
TM9V100C16MP11C	CF/CM/CU60C	1.01	0.99	0.95
TM9V100C16MP11C	CF/CM/CU60D	1.01	1.01	0.95
TM9V100C16MP11C	CF/CM64D	1.01	0.98	0.93
TM9V100C16MP12C	CF/CM/CU48C	0.99	0.99	0.93
TM9V100C16MP12C	CF/CM/CU48D	0.99	0.99	0.93
TM9V100C16MP12C	CF/CM/CU60C	0.98	0.98	0.92
TM9V100C16MP12C	CF/CM/CU60D	0.99	1.02	0.93
TM9V100C16MP12C	CF/CM64D	0.98	1.00	0.90

FURNACE MULTIPLIERS- 4 TON (Continued)

Furnaces	Coil	T.C.	S.C.	KW
TM9V100C20MP11C	CF/CM/CU48C	1.01	1.01	0.97
TM9V100C20MP11C	CF/CM/CU48D	1.01	0.98	0.95
TM9V100C20MP11C	CF/CM/CU60C	1.01	1.04	0.95
TM9V100C20MP11C	CF/CM/CU60D	1.01	0.98	0.93
TM9V100C20MP11C	CF/CM64D	1.01	0.98	0.93
TM9V100C20MP12C	CF/CM/CU48C	1.00	1.00	0.96
TM9V100C20MP12C	CF/CM/CU48D	1.00	0.99	0.94
TM9V100C20MP12C	CF/CM/CU60C	1.00	1.01	0.96
TM9V100C20MP12C	CF/CM/CU60D	0.98	0.98	0.92
TM9V100C20MP12C	CF/CM64D	0.98	1.02	0.90
TM9V120D20MP11C	CF/CM/CU48D	1.01	0.98	0.93
TM9V120D20MP11C	CF/CM/CU60D	1.01	0.98	0.93
TM9V120D20MP11C	CF/CM64D	1.01	1.04	0.95
TM9V120D20MP12C	CF/CM/CU48D	0.98	1.00	0.92
TM9V120D20MP12C	CF/CM/CU60D	1.01	1.07	0.93
TM9V120D20MP12C	CF/CM64D	1.01	1.07	0.95
TM9Y080C16MP11	CF/CM/CU48C	1.01	0.98	0.95
TM9Y080C16MP11	CF/CM/CU48D	1.01	0.98	0.95
TM9Y080C16MP11	CF/CM/CU60C	1.01	0.99	0.95
TM9Y080C16MP11	CF/CM/CU60D	1.01	0.99	0.95
TM9Y080C16MP11	CF/CM64D	1.01	0.98	0.93
TM9Y100C16MP11	CF/CM/CU48C	1.01	0.98	0.95
TM9Y100C16MP11	CF/CM/CU48D	1.01	0.98	0.95
TM9Y100C16MP11	CF/CM/CU60C	1.01	0.99	0.95
TM9Y100C16MP11	CF/CM/CU60D	1.01	0.99	0.95
TM9Y100C16MP11	CF/CM64D	1.01	0.98	0.93
TM9Y100C20MP11	CF/CM/CU48C	1.01	1.02	0.95
TM9Y100C20MP11	CF/CM/CU48D	1.01	1.01	0.93
TM9Y100C20MP11	CF/CM/CU60C	1.01	1.01	0.93
TM9Y100C20MP11	CF/CM/CU60D	1.01	1.03	0.93
TM9Y100C20MP11	CF/CM64D	1.01	1.01	0.93
TM9Y120D20MP11	CF/CM/CU48D	1.01	1.01	0.93
TM9Y120D20MP11	CF/CM/CU60D	1.01	1.02	0.93
TM9Y120D20MP11	CF/CM64D	1.01	1.01	0.93
TMLV080C16MP12C	CF/CM/CU48C	0.99	1.01	0.93
TMLV080C16MP12C	CF/CM/CU48D	1.01	1.03	0.95
TMLV080C16MP12C	CF/CM/CU60C	0.99	1.02	0.93
TMLV080C16MP12C	CF/CM/CU60D	0.99	1.02	0.91
TMLV080C16MP12C	CF/CM64D	1.01	1.04	0.93
TMLV100C16MP12C	CF/CM/CU48C	0.99	1.01	0.93
TMLV100C16MP12C	CF/CM/CU48D	1.01	1.03	0.95
TMLV100C16MP12C	CF/CM/CU60C	0.99	1.02	0.93
TMLV100C16MP12C	CF/CM/CU60D	0.99	1.02	0.91
TMLV100C16MP12C	CF/CM64D	1.01	1.04	0.93
TMLV100C20MP12C	CF/CM/CU48C	0.99	1.01	0.93
TMLV100C20MP12C	CF/CM/CU48D	1.01	1.01	0.93
TMLV100C20MP12C	CF/CM/CU60C	1.00	1.01	0.92
TMLV100C20MP12C	CF/CM/CU60D	1.01	1.05	0.95
TMLV100C20MP12C	CF/CM64D	1.00	1.02	0.94
TMLV120C20MP12C	CF/CM/CU48C	0.99	1.01	0.93
TMLV120C20MP12C	CF/CM/CU48D	1.01	1.01	0.93
TMLV120C20MP12C	CF/CM/CU60C	1.00	1.01	0.92
TMLV120C20MP12C	CF/CM/CU60D	1.01	1.05	0.95
TMLV120C20MP12C	CF/CM64D	1.00	1.02	0.94
TMLX080C16MP11	CF/CM/CU48C	1.01	1.02	0.95

FURNACE MULTIPLIERS- 4 TON (Continued)

Furnaces	Coil	T.C.	S.C.	KW
TMLX080C16MP11	CF/CM/CU48D	1.01	1.00	0.95
TMLX080C16MP11	CF/CM/CU60C	1.01	1.01	0.95
TMLX080C16MP11	CF/CM/CU60D	1.01	1.01	0.93
TMLX080C16MP11	CF/CM64D	1.01	1.01	0.93
TMLX100C16MP11	CF/CM/CU48C	1.01	1.02	0.95
TMLX100C16MP11	CF/CM/CU48D	1.01	1.00	0.95
TMLX100C16MP11	CF/CM/CU60C	1.01	1.01	0.95
TMLX100C16MP11	CF/CM/CU60D	1.01	1.01	0.93
TMLX100C16MP11	CF/CM64D	1.01	1.01	0.93
TMLX100C20MP11	CF/CM/CU48C	1.01	1.01	0.93
TMLX100C20MP11	CF/CM/CU48D	1.01	0.98	0.91
TMLX100C20MP11	CF/CM/CU60C	1.01	1.03	0.93
TMLX100C20MP11	CF/CM/CU60D	1.01	1.03	0.91
TMLX100C20MP11	CF/CM64D	1.01	1.02	0.91
TMLX120C20MP11	CF/CM/CU48C	1.01	1.01	0.93
TMLX120C20MP11	CF/CM/CU48D	1.01	0.98	0.91
TMLX120C20MP11	CF/CM/CU60C	1.01	1.03	0.93
TMLX120C20MP11	CF/CM/CU60D	1.01	1.03	0.91
TMLX120C20MP11	CF/CM64D	1.01	1.02	0.91
TP9C080C16MP12C	CF/CM/CU48C	1.01	1.01	0.95
TP9C080C16MP12C	CF/CM/CU48D	1.01	1.01	0.91
TP9C080C16MP12C	CF/CM/CU60C	1.01	0.99	0.95
TP9C080C16MP12C	CF/CM/CU60D	1.01	1.01	0.95
TP9C080C16MP12C	CF/CM64D	1.01	0.98	0.93
TP9C080C16MP13C	CF/CM/CU48C	0.99	0.97	0.93
TP9C080C16MP13C	CF/CM/CU48D	0.99	0.96	0.91
TP9C080C16MP13C	CF/CM/CU60C	0.99	0.97	0.93
TP9C080C16MP13C	CF/CM/CU60D	0.99	0.97	0.93
TP9C080C16MP13C	CF/CM64D	0.99	0.98	0.91
TP9C100C16MP12C	CF/CM/CU48C	1.01	1.01	0.95
TP9C100C16MP12C	CF/CM/CU48D	1.01	1.01	0.91
TP9C100C16MP12C	CF/CM/CU60C	1.01	0.99	0.95
TP9C100C16MP12C	CF/CM/CU60D	1.01	1.01	0.95
TP9C100C16MP12C	CF/CM64D	1.01	0.98	0.93
TP9C100C16MP13C	CF/CM/CU48C	0.99	0.99	0.93
TP9C100C16MP13C	CF/CM/CU48D	0.99	0.99	0.93
TP9C100C16MP13C	CF/CM/CU60C	0.98	0.98	0.92
TP9C100C16MP13C	CF/CM/CU60D	0.99	1.02	0.93
TP9C100C16MP13C	CF/CM64D	0.98	1.00	0.90
TP9C100C20MP12C	CF/CM/CU48C	1.01	1.01	0.97
TP9C100C20MP12C	CF/CM/CU48D	1.01	0.98	0.95
TP9C100C20MP12C	CF/CM/CU60C	1.01	1.04	0.95
TP9C100C20MP12C	CF/CM/CU60D	1.01	0.98	0.93
TP9C100C20MP12C	CF/CM64D	1.01	0.98	0.93
TP9C100C20MP13C	CF/CM/CU48C	1.00	1.00	0.96
TP9C100C20MP13C	CF/CM/CU48D	1.00	0.99	0.94
TP9C100C20MP13C	CF/CM/CU60C	1.00	1.01	0.96
TP9C100C20MP13C	CF/CM/CU60D	0.98	0.98	0.92
TP9C100C20MP13C	CF/CM64D	0.98	1.02	0.90
TP9C120D20MP13C	CF/CM/CU48D	0.98	1.00	0.92
TP9C120D20MP13C	CF/CM/CU60D	1.01	1.07	0.93
TP9C120D20MP13C	CF/CM64D	1.01	1.07	0.95
TPLC080C16MP12C	CF/CM/CU48C	1.01	0.98	0.95
TPLC080C16MP12C	CF/CM/CU48D	1.01	0.98	0.95
TPLC080C16MP12C	CF/CM/CU60C	1.01	0.98	0.93

FURNACE MULTIPLIERS- 4 TON (Continued)

Furnaces	Coil	T.C.	S.C.	KW
TPLC080C16MP12C	CF/CM/CU60D	1.01	0.98	0.93
TPLC080C16MP12C	CF/CM64D	1.01	1.01	0.93
TPLC080C16MP13C	CF/CM/CU48C	0.99	1.01	0.93
TPLC080C16MP13C	CF/CM/CU48D	1.01	1.03	0.95
TPLC080C16MP13C	CF/CM/CU60C	0.99	1.02	0.93
TPLC080C16MP13C	CF/CM/CU60D	0.99	1.02	0.91
TPLC080C16MP13C	CF/CM64D	1.01	1.04	0.93
TPLC100C16MP12C	CF/CM/CU48C	1.01	0.98	0.95
TPLC100C16MP12C	CF/CM/CU48D	1.01	0.98	0.95
TPLC100C16MP12C	CF/CM/CU60C	1.01	0.98	0.93
TPLC100C16MP12C	CF/CM/CU60D	1.01	0.98	0.93
TPLC100C16MP12C	CF/CM64D	1.01	1.01	0.93
TPLC100C16MP13C	CF/CM/CU48C	0.99	1.01	0.93
TPLC100C16MP13C	CF/CM/CU48D	1.01	1.03	0.95
TPLC100C16MP13C	CF/CM/CU60C	0.99	1.02	0.93
TPLC100C16MP13C	CF/CM/CU60D	0.99	1.02	0.91
TPLC100C16MP13C	CF/CM64D	1.01	1.04	0.93
TPLC100C20MP13C	CF/CM/CU48C	0.99	1.01	0.93
TPLC100C20MP13C	CF/CM/CU48D	1.01	1.01	0.93
TPLC100C20MP13C	CF/CM/CU60C	1.00	1.01	0.92
TPLC100C20MP13C	CF/CM/CU60D	1.01	1.05	0.95
TPLC100C20MP13C	CF/CM64D	1.00	1.02	0.94
TPLC120C20MP13C	CF/CM/CU48C	0.99	1.01	0.93
TPLC120C20MP13C	CF/CM/CU48D	1.01	1.01	0.93
TPLC120C20MP13C	CF/CM/CU60C	1.00	1.01	0.92
TPLC120C20MP13C	CF/CM/CU60D	1.01	1.05	0.95
TPLC120C20MP13C	CF/CM64D	1.00	1.02	0.94
CP9C080C16MP12C	CF/CM/CU48C	1.01	1.01	0.95
CP9C080C16MP12C	CF/CM/CU48D	1.01	1.01	0.91
CP9C080C16MP12C	CF/CM/CU60C	1.01	0.99	0.95
CP9C080C16MP12C	CF/CM/CU60D	1.01	1.01	0.95
CP9C080C16MP12C	CF/CM64D	1.01	0.98	0.93
CP9C080C16MP13C	CF/CM/CU48C	0.99	0.97	0.93
CP9C080C16MP13C	CF/CM/CU48D	0.99	0.96	0.91
CP9C080C16MP13C	CF/CM/CU60C	0.99	0.97	0.93
CP9C080C16MP13C	CF/CM/CU60D	0.99	0.97	0.93
CP9C080C16MP13C	CF/CM64D	0.99	0.98	0.91
CP9C100C16MP12C	CF/CM/CU48C	1.01	1.01	0.95
CP9C100C16MP12C	CF/CM/CU48D	1.01	1.01	0.91
CP9C100C16MP12C	CF/CM/CU60C	1.01	0.99	0.95
CP9C100C16MP12C	CF/CM/CU60D	1.01	1.01	0.95
CP9C100C16MP12C	CF/CM64D	1.01	0.98	0.93
CP9C100C16MP13C	CF/CM/CU48C	0.99	0.99	0.93
CP9C100C16MP13C	CF/CM/CU48D	0.99	0.99	0.93
CP9C100C16MP13C	CF/CM/CU60C	0.98	0.98	0.92
CP9C100C16MP13C	CF/CM/CU60D	0.99	1.02	0.93
CP9C100C16MP13C	CF/CM64D	0.98	1.00	0.90
CP9C100C20MP12C	CF/CM/CU48C	1.01	1.01	0.97
CP9C100C20MP12C	CF/CM/CU48D	1.01	0.98	0.95
CP9C100C20MP12C	CF/CM/CU60C	1.01	1.04	0.95
CP9C100C20MP12C	CF/CM/CU60D	1.01	0.98	0.93
CP9C100C20MP12C	CF/CM64D	1.01	0.98	0.93
CP9C100C20MP13C	CF/CM/CU48C	1.00	1.00	0.96

FURNACE MULTIPLIERS- 4 TON (Continued)

Furnaces	Coil	T.C.	S.C.	KW
CP9C100C20MP13C	CF/CM/CU48D	1.00	0.99	0.94
CP9C100C20MP13C	CF/CM/CU60C	1.00	1.01	0.96
CP9C100C20MP13C	CF/CM/CU60D	0.98	0.98	0.92
CP9C100C20MP13C	CF/CM64D	0.98	1.02	0.90
CP9C120D20MP12C	CF/CM/CU48D	1.01	0.98	0.93
CP9C120D20MP12C	CF/CM/CU60D	1.01	0.98	0.93
CP9C120D20MP12C	CF/CM64D	1.01	1.04	0.95
CP9C120D20MP13C	CF/CM/CU48D	0.98	1.00	0.92
CP9C120D20MP13C	CF/CM/CU60D	1.01	1.07	0.93
CP9C120D20MP13C	CF/CM64D	1.01	1.07	0.95
CPLC080C16MP12C	CF/CM/CU48C	1.01	0.98	0.95
CPLC080C16MP12C	CF/CM/CU48D	1.01	0.98	0.95
CPLC080C16MP12C	CF/CM/CU60C	1.01	0.98	0.93
CPLC080C16MP12C	CF/CM/CU60D	1.01	0.98	0.93
CPLC080C16MP12C	CF/CM64D	1.01	1.01	0.93
CPLC080C16MP13C	CF/CM/CU48C	0.99	1.01	0.93
CPLC080C16MP13C	CF/CM/CU48D	1.01	1.03	0.95
CPLC080C16MP13C	CF/CM/CU60C	0.99	1.02	0.93
CPLC080C16MP13C	CF/CM/CU60D	0.99	1.02	0.91
CPLC080C16MP13C	CF/CM64D	1.01	1.04	0.93
CPLC100C16MP12C	CF/CM/CU48C	1.01	0.98	0.95
CPLC100C16MP12C	CF/CM/CU48D	1.01	0.98	0.95
CPLC100C16MP12C	CF/CM/CU60C	1.01	0.98	0.93
CPLC100C16MP12C	CF/CM/CU60D	1.01	0.98	0.93
CPLC100C16MP12C	CF/CM64D	1.01	1.01	0.93
CPLC100C16MP13C	CF/CM/CU48C	0.99	1.01	0.93
CPLC100C16MP13C	CF/CM/CU48D	1.01	1.03	0.95
CPLC100C16MP13C	CF/CM/CU60C	0.99	1.02	0.93
CPLC100C16MP13C	CF/CM/CU60D	0.99	1.02	0.91
CPLC100C16MP13C	CF/CM64D	1.01	1.04	0.93
CPLC100C20MP12C	CF/CM/CU48C	1.01	0.98	0.95
CPLC100C20MP12C	CF/CM/CU48D	1.01	1.03	0.93
CPLC100C20MP12C	CF/CM/CU60C	1.01	1.01	0.93
CPLC100C20MP12C	CF/CM/CU60D	1.01	0.99	0.95
CPLC100C20MP12C	CF/CM64D	1.01	1.02	0.93
CPLC100C20MP13C	CF/CM/CU48C	0.99	1.01	0.93
CPLC100C20MP13C	CF/CM/CU48D	1.01	1.01	0.93
CPLC100C20MP13C	CF/CM/CU60C	1.00	1.01	0.92
CPLC100C20MP13C	CF/CM/CU60D	1.01	1.05	0.95
CPLC100C20MP13C	CF/CM64D	1.00	1.02	0.94
CPLC120C20MP12C	CF/CM/CU48C	1.01	0.98	0.95
CPLC120C20MP12C	CF/CM/CU48D	1.01	1.03	0.93
CPLC120C20MP12C	CF/CM/CU60C	1.01	1.01	0.93
CPLC120C20MP12C	CF/CM/CU60D	1.01	0.99	0.95
CPLC120C20MP12C	CF/CM64D	1.01	1.02	0.93
CPLC120C20MP13C	CF/CM/CU48C	0.99	1.01	0.93
CPLC120C20MP13C	CF/CM/CU48D	1.01	1.01	0.93
CPLC120C20MP13C	CF/CM/CU60C	1.00	1.01	0.92
CPLC120C20MP13C	CF/CM/CU60D	1.01	1.05	0.95
CPLC120C20MP13C	CF/CM64D	1.00	1.02	0.94

PERFORMANCE DATA - 5 TON

CONDENSER-ONLY DATA (OUTDOOR UNIT)																		
MODEL	SATURATED SUCTION @ COMPRESSOR		Outdoor Ambient Temperature															
			55 °F		65 °F		75 °F		85 °F		95 °F		105 °F		115 °F		125 °F	
	T (°F)	P (PSIG)	MBH	KW	MBH	KW	MBH	KW	MBH	KW	MBH	KW	MBH	KW	MBH	KW	MBH	KW
TW4B6021S	35	107	61.4	2.72	58.5	2.99	55.5	3.32	52.5	3.70	49.3	4.16	46.0	4.70	42.3	5.30	38.4	6.00
	40	118	67.5	2.73	64.3	3.00	61.1	3.33	57.8	3.71	54.4	4.17	50.7	4.70	46.9	5.31	42.7	6.00
	45	130	73.9	2.74	70.5	3.01	67.1	3.34	63.5	3.72	59.8	4.17	55.8	4.71	51.7	5.32	47.2	5.99
	50	142	80.8	2.75	77.0	3.03	73.3	3.35	69.5	3.73	65.6	4.17	61.3	4.72	56.8	5.33	52.1	5.99
	55	156	88.2	2.76	84.1	3.04	80.0	3.37	75.8	3.76	71.6	4.19	67.1	4.73	62.3	5.34	57.3	5.99

Notes:

- For Outdoor Unit (Condenser) performance only. Data does not include the effects of air handler power or heat.
- Performance based on 15°F subcooling and 15°F superheat at the Outdoor Unit base valves.
 - Increase capacity by 1% for each 2°F increase in subcooling.
 - Decrease capacity by 1% for each 2°F decrease in subcooling.
- Maximum recommended condensing temperature is 140°F.

COOLING PERFORMANCE DATA																
OUTDOOR UNIT MODEL NO.		TW4B6021S														
INDOOR COIL MODEL NO.		CF60CXA1														
AIR TEMP. ENTERING OUTDOOR UNIT (°F)	ID CFM	1530					1730					1930				
	ID DB (°F)	80	80	75	80	80	80	80	75	80	80	80	80	75	80	80
	ID WB (°F)	57	62	62	67	72	57	62	62	67	72	57	62	62	67	72
55	T.C.	55.3	58.7	59.6	63.7	66.8	57.5	59.6	60.2	64.3	67.1	59.7	60.5	60.7	65.0	67.5
	S.C.	55.3	49.6	44.3	43.0	33.6	57.5	52.4	46.2	44.3	34.5	59.7	55.2	48.1	45.7	35.4
	KW	3.10	3.14	3.13	3.15	3.17	3.19	3.22	3.21	3.24	3.25	3.27	3.30	3.29	3.32	3.33
65	T.C.	54.1	57.2	57.2	62.0	65.7	56.1	58.2	58.0	62.9	66.4	58.0	59.1	58.9	63.8	67.1
	S.C.	54.1	49.2	42.6	41.9	33.0	56.1	52.1	44.9	43.7	34.1	58.0	54.9	47.2	45.5	35.1
	KW	3.43	3.46	3.45	3.47	3.48	3.51	3.54	3.53	3.55	3.56	3.59	3.62	3.61	3.63	3.64
75	T.C.	52.9	55.6	54.7	60.3	64.7	54.6	56.7	55.9	61.5	65.7	56.4	57.8	57.1	62.6	66.8
	S.C.	52.9	48.9	40.9	40.9	32.5	54.6	51.7	43.6	43.2	33.7	56.4	54.6	46.3	45.4	34.8
	KW	3.76	3.78	3.77	3.78	3.78	3.84	3.86	3.85	3.86	3.86	3.91	3.93	3.92	3.94	3.94
85	T.C.	50.4	53.2	52.1	57.9	62.4	52.1	54.2	53.4	58.7	63.3	53.7	55.1	54.7	59.6	64.1
	S.C.	50.4	47.4	39.6	39.9	31.5	52.1	50.2	42.3	42.1	32.6	53.7	52.9	45.0	44.2	33.8
	KW	4.22	4.25	4.25	4.24	4.23	4.30	4.32	4.31	4.31	4.30	4.37	4.39	4.38	4.39	4.38
95	T.C.	47.9	50.8	49.6	55.4	60.2	49.5	51.6	50.9	56.0	60.8	51.1	52.5	52.3	56.6	61.4
	S.C.	47.9	46.0	38.3	38.9	30.5	49.5	48.6	41.0	41.0	31.6	51.1	51.2	43.7	43.1	32.7
	KW	4.69	4.71	4.72	4.70	4.67	4.75	4.78	4.78	4.77	4.75	4.82	4.84	4.84	4.83	4.82
105	T.C.	46.0	47.7	46.1	52.4	57.0	47.5	48.6	47.5	53.0	57.4	49.0	49.6	48.8	53.6	57.8
	S.C.	46.0	44.5	36.4	37.6	29.1	47.5	46.9	39.0	39.7	30.2	49.0	49.3	41.7	41.8	31.4
	KW	5.49	5.51	5.51	5.47	5.41	5.52	5.56	5.57	5.53	5.48	5.56	5.61	5.63	5.58	5.56
115	T.C.	44.1	44.7	42.8	49.5	53.8	45.5	45.7	44.1	50.1	54.0	46.9	46.7	45.4	50.7	54.2
	S.C.	44.1	43.0	34.6	36.3	27.7	45.5	45.3	37.1	38.4	28.9	46.9	46.7	39.7	40.5	30.0
	KW	6.26	6.29	6.28	6.22	6.13	6.27	6.32	6.34	6.26	6.20	6.28	6.36	6.39	6.31	6.28
125	T.C.	42.3	41.8	39.4	46.5	50.7	43.6	42.8	40.7	47.2	50.7	44.9	43.9	42.0	47.8	50.7
	S.C.	42.3	41.6	32.7	35.0	26.4	43.6	42.8	35.2	37.1	27.5	44.9	43.9	37.8	39.3	28.7
	KW	7.03	7.07	7.05	6.96	6.84	7.02	7.08	7.10	7.00	6.92	7.00	7.10	7.15	7.04	7.00

NOTE: ALL CAPACITIES INCLUDE INDOOR FAN HEAT. KW VALUES ARE FOR THE SYSTEM (OUTDOOR + INDOOR).

Green shaded cells are ACCA (TVA) conditions.

Blue shaded cells are AHRI conditions.

Multipliers for determining the performance with other indoor sections.

NOTE: For dry bulb temperatures different than those listed (between 73-87 °F), sensible capacity increases by 1060 BTUH per 1000 CFM per degree above the listed temperature and decreases by 1060 BTUH per 1000 CFM per degree below the listed temperature.

COIL MULTIPLIERS- 5 TON

Air Handler	Coil	T.C.	S.C.	KW
-	CF/CM/CU60C	1.00	1.00	1.00
-	CF/CM/CU60D	1.00	1.00	1.00
-	CF/CM64D	1.02	1.02	1.02
AE60CX21	-	1.00	0.98	0.98
AE60DX21	-	1.03	1.02	0.98
AP60DX22	-	0.97	0.93	0.97
AVC60CX21	-	1.01	1.01	0.99
AVC60DX21	-	1.03	1.00	0.98
ME16CN21	CF/CM60C	1.00	0.98	0.96
ME20DN21	CF/CM60D	1.01	0.98	0.97
ME20DN21	CF/CM64D	1.03	0.99	0.98
MVC16CN21	CF/CM60C	1.02	0.99	0.94
MVC20DN21	CF/CM60D	1.00	0.98	0.96
MVC20DN21	CF/CM64D	1.02	0.99	0.98

FURNACE MULTIPLIERS- 5 TON

Furnaces	Coil	T.C.	S.C.	KW
TL8E080C16UH11	CF/CM/CU60D	0.99	0.99	0.99
TL8E080C16UH11	CF/CM64D	1.00	0.99	0.98
TL8E100C20UH11	CF/CM/CU60C	0.98	0.98	0.98
TL8E100C20UH11	CF/CM/CU60D	1.00	1.01	0.98
TL8E100C20UH11	CF/CM64D	1.02	1.01	0.98
TL9E100C20UH11	CF/CM/CU60C	0.97	0.96	0.97
TL9E100C20UH11	CF/CM/CU60D	1.00	1.01	0.98
TL9E100C20UH11	CF/CM64D	1.02	1.01	1.00
TM8E080C16MP11	CF/CM/CU60D	0.99	1.00	0.99
TM8E080C16MP11	CF/CM64D	1.01	1.00	0.99
TM8E080C20MP11	CF/CM/CU60C	0.98	0.96	0.98
TM8E080C20MP11	CF/CM/CU60D	0.99	0.99	0.97
TM8E080C20MP11	CF/CM64D	1.01	1.00	0.97
TM8E100C16MP11	CF/CM/CU60D	0.99	1.00	0.99
TM8E100C16MP11	CF/CM64D	1.01	1.00	0.99
TM8E100C20MP11	CF/CM/CU60D	0.99	0.98	0.97
TM8E100C20MP11	CF/CM64D	1.01	0.99	0.97
TM8E120C16MP11	CF/CM/CU60D	0.99	1.00	0.99
TM8E120C16MP11	CF/CM64D	1.01	1.00	0.99
TM8E120C20MP11	CF/CM/CU60D	0.99	0.98	0.97
TM8E120C20MP11	CF/CM64D	1.01	0.99	0.97
TM8E130D20MP11	CF/CM/CU60D	1.00	1.01	0.98
TM8E130D20MP11	CF/CM64D	1.02	1.02	0.98
TM8V080C16MP11C	CF/CM/CU60D	0.99	1.01	1.00
TM8V080C16MP12C	CF/CM/CU60D	0.99	1.01	1.00
TM8V100C16MP11C	CF/CM/CU60D	0.99	1.01	1.00
TM8V100C16MP12C	CF/CM/CU60D	0.99	1.01	1.00
TM8V100C20MP11C	CF/CM/CU60C	0.98	1.00	0.98
TM8V100C20MP11C	CF/CM/CU60D	0.99	1.00	0.97
TM8V100C20MP12C	CF/CM/CU60C	0.98	1.00	0.98
TM8V100C20MP12C	CF/CM/CU60D	0.99	1.00	0.97
TM8V100C20MP12C	CF/CM64D	0.99	0.98	0.95
TM8V120C20MP11C	CF/CM/CU60C	0.98	1.00	0.98
TM8V120C20MP12C	CF/CM/CU60C	0.98	1.00	0.98
TM8V120C20MP12C	CF/CM/CU60D	0.99	1.00	0.97
TM8V120C20MP12C	CF/CM64D	0.99	0.98	0.95
TM8X080C16MP11	CF/CM/CU60D	0.96	0.95	0.97
TM8X080C16MP11	CF/CM64D	0.97	0.96	0.98
TM8X100C16MP11	CF/CM/CU60D	0.96	0.95	0.97

FURNACE MULTIPLIERS- 5 TON (Continued)

Furnaces	Coil	T.C.	S.C.	KW
TM8X100C16MP11	CF/CM64D	0.97	0.96	0.98
TM8X100C20MP11	CF/CM/CU60C	0.97	0.96	0.95
TM8X100C20MP11	CF/CM/CU60D	0.98	0.99	0.96
TM8X100C20MP11	CF/CM64D	0.99	0.98	0.95
TM8X120C20MP11	CF/CM/CU60C	0.97	0.96	0.95
TM8X120C20MP11	CF/CM/CU60D	0.98	0.99	0.96
TM8X120C20MP11	CF/CM64D	0.99	0.98	0.95
TM8Y080C16MP11	CF/CM/CU60D	0.96	0.95	0.97
TM8Y080C16MP11	CF/CM64D	0.97	0.96	0.98
TM8Y100C16MP11	CF/CM/CU60D	0.96	0.95	0.97
TM8Y100C16MP11	CF/CM64D	0.97	0.96	0.98
TM8Y100C20MP11	CF/CM/CU60C	0.97	0.96	0.95
TM8Y100C20MP11	CF/CM/CU60D	0.98	0.99	0.96
TM8Y100C20MP11	CF/CM64D	0.99	0.98	0.95
TM8Y120C20MP11	CF/CM/CU60C	0.97	0.96	0.95
TM8Y120C20MP11	CF/CM/CU60D	0.98	0.99	0.96
TM8Y120C20MP11	CF/CM64D	0.99	0.98	0.95
TM9E080C20MP12	CF/CM/CU60D	0.99	0.98	0.97
TM9E080C20MP12	CF/CM64D	1.03	1.06	1.01
TM9E100C20MP11	CF/CM/CU60C	0.96	0.95	0.97
TM9E100C20MP11	CF/CM/CU60D	0.97	0.96	0.97
TM9E100C20MP11	CF/CM64D	0.98	0.97	0.98
TM9E100C20MP12	CF/CM/CU60D	0.99	0.98	0.97
TM9E100C20MP12	CF/CM64D	1.01	0.99	0.97
TM9E120D20MP11	CF/CM/CU60D	0.98	0.99	0.96
TM9E120D20MP11	CF/CM64D	0.99	0.99	0.99
TM9E120D20MP12	CF/CM/CU60D	1.00	1.01	0.98
TM9E120D20MP12	CF/CM64D	1.02	1.01	1.00
TM9V100C16MP11C	CF/CM/CU60C	0.97	0.98	0.97
TM9V100C16MP11C	CF/CM/CU60D	0.98	0.99	0.98
TM9V100C16MP11C	CF/CM64D	1.00	0.99	0.98
TM9V100C16MP12C	CF/CM/CU60C	0.97	0.98	0.97
TM9V100C16MP12C	CF/CM/CU60D	0.98	0.99	0.98
TM9V100C16MP12C	CF/CM64D	1.00	0.99	0.98
TM9V100C20MP11C	CF/CM/CU60C	0.98	0.99	0.99
TM9V100C20MP11C	CF/CM64D	1.00	0.99	1.00
TM9V100C20MP12C	CF/CM/CU60C	0.98	0.99	0.99
TM9V100C20MP12C	CF/CM64D	1.00	0.99	1.00
TM9V120D20MP11C	CF/CM/CU60D	0.98	0.99	0.98
TM9V120D20MP11C	CF/CM64D	0.99	0.99	0.99
TM9V120D20MP12C	CF/CM/CU60D	0.98	0.99	0.98
TM9V120D20MP12C	CF/CM64D	0.99	0.98	0.99
TM9Y100C20MP11	CF/CM/CU60C	0.96	0.95	0.97
TM9Y100C20MP11	CF/CM/CU60D	0.97	0.96	0.97
TM9Y100C20MP11	CF/CM64D	0.98	0.97	0.98
TM9Y120D20MP11	CF/CM/CU60D	0.98	0.99	0.96
TM9Y120D20MP11	CF/CM64D	0.99	0.99	0.99
TMLV080C16MP11C	CF/CM/CU60D	0.99	1.01	1.00
TMLV080C16MP12C	CF/CM/CU60D	0.99	1.01	1.00
TMLV100C16MP11C	CF/CM/CU60D	0.99	1.01	1.00
TMLV100C16MP12C	CF/CM/CU60D	0.99	1.01	1.00
TMLV100C20MP11C	CF/CM/CU60C	0.98	1.00	0.98
TMLV100C20MP12C	CF/CM/CU60C	0.98	1.00	0.98
TMLV100C20MP12C	CF/CM/CU60D	0.99	1.00	0.97
TMLV100C20MP12C	CF/CM64D	0.99	0.98	0.95
TMLV120C20MP11C	CF/CM/CU60C	0.98	1.00	0.98

FURNACE MULTIPLIERS- 5 TON (Continued)

Furnaces	Coil	T.C.	S.C.	KW
TMLV120C20MP12C	CF/CM/CU60C	0.98	1.00	0.98
TMLV120C20MP12C	CF/CM/CU60D	0.99	1.00	0.97
TMLV120C20MP12C	CF/CM64D	0.99	0.98	0.95
TMLX080C16MP11	CF/CM/CU60D	0.96	0.95	0.97
TMLX080C16MP11	CF/CM64D	0.97	0.96	0.98
TMLX100C16MP11	CF/CM/CU60D	0.96	0.95	0.97
TMLX100C16MP11	CF/CM64D	0.97	0.96	0.98
TMLX100C20MP11	CF/CM/CU60C	0.97	0.96	0.95
TMLX100C20MP11	CF/CM/CU60D	0.98	0.99	0.96
TMLX100C20MP11	CF/CM64D	0.99	0.98	0.95
TMLX120C20MP11	CF/CM/CU60C	0.97	0.96	0.95
TMLX120C20MP11	CF/CM/CU60D	0.98	0.99	0.96
TMLX120C20MP11	CF/CM64D	0.99	0.98	0.95
TP9C100C16MP12C	CF/CM/CU60C	0.97	0.98	0.97
TP9C100C16MP12C	CF/CM/CU60D	0.98	0.99	0.98
TP9C100C16MP12C	CF/CM64D	1.00	0.99	0.98
TP9C100C16MP13C	CF/CM/CU60C	0.97	0.98	0.97
TP9C100C16MP13C	CF/CM/CU60D	0.98	0.99	0.98
TP9C100C16MP13C	CF/CM64D	1.00	0.99	0.98
TP9C100C20MP12C	CF/CM/CU60C	0.98	0.99	0.99
TP9C100C20MP12C	CF/CM64D	1.00	0.99	1.00
TP9C100C20MP13C	CF/CM/CU60C	0.98	0.99	0.99
TP9C100C20MP13C	CF/CM64D	1.00	0.99	1.00
TP9C120D20MP13C	CF/CM/CU60D	0.98	0.99	0.98
TP9C120D20MP13C	CF/CM64D	0.99	0.98	0.99
TPLC080C16MP12C	CF/CM/CU60D	0.99	1.01	1.00
TPLC080C16MP13C	CF/CM/CU60D	0.99	1.01	1.00
TPLC100C16MP12C	CF/CM/CU60D	0.99	1.01	1.00
TPLC100C16MP13C	CF/CM/CU60D	0.99	1.01	1.00
TPLC100C20MP12C	CF/CM/CU60C	0.98	1.00	0.98
TPLC100C20MP13C	CF/CM/CU60C	0.98	1.00	0.98
TPLC100C20MP13C	CF/CM/CU60D	0.99	1.00	0.97
TPLC100C20MP13C	CF/CM64D	0.99	0.98	0.95
TPLC120C20MP12C	CF/CM/CU60C	0.98	1.00	0.98

FURNACE MULTIPLIERS- 5 TON (Continued)

Furnaces	Coil	T.C.	S.C.	KW
TPLC120C20MP13C	CF/CM/CU60C	0.98	1.00	0.98
TPLC120C20MP13C	CF/CM/CU60D	0.99	1.00	0.97
TPLC120C20MP13C	CF/CM64D	0.99	0.98	0.95
CP9C100C16MP12C	CF/CM/CU60C	0.97	0.98	0.97
CP9C100C16MP12C	CF/CM/CU60D	0.98	0.99	0.98
CP9C100C16MP12C	CF/CM64D	1.00	0.99	0.98
CP9C100C16MP13C	CF/CM/CU60C	0.97	0.98	0.97
CP9C100C16MP13C	CF/CM/CU60D	0.98	0.99	0.98
CP9C100C16MP13C	CF/CM64D	1.00	0.99	0.98
CP9C100C20MP12C	CF/CM/CU60C	0.98	0.99	0.99
CP9C100C20MP12C	CF/CM64D	1.00	0.99	1.00
CP9C100C20MP13C	CF/CM/CU60C	0.98	0.99	0.99
CP9C100C20MP13C	CF/CM64D	1.00	0.99	1.00
CP9C120D20MP12C	CF/CM/CU60D	0.98	0.99	0.98
CP9C120D20MP12C	CF/CM64D	0.99	0.99	0.99
CP9C120D20MP13C	CF/CM/CU60D	0.98	0.99	0.98
CP9C120D20MP13C	CF/CM64D	0.99	0.98	0.99
CPLC080C16MP12C	CF/CM/CU60D	0.99	1.01	1.00
CPLC080C16MP13C	CF/CM/CU60D	0.99	1.01	1.00
CPLC100C16MP12C	CF/CM/CU60D	0.99	1.01	1.00
CPLC100C16MP13C	CF/CM/CU60D	0.99	1.01	1.00
CPLC100C20MP12C	CF/CM/CU60C	0.98	1.00	0.98
CPLC100C20MP12C	CF/CM/CU60D	0.99	1.00	0.97
CPLC100C20MP13C	CF/CM/CU60C	0.98	1.00	0.98
CPLC100C20MP13C	CF/CM/CU60D	0.99	1.00	0.97
CPLC100C20MP13C	CF/CM64D	0.99	0.98	0.95
CPLC120C20MP12C	CF/CM/CU60C	0.98	1.00	0.98
CPLC120C20MP12C	CF/CM/CU60D	0.99	1.00	0.97
CPLC120C20MP13C	CF/CM/CU60C	0.98	1.00	0.98
CPLC120C20MP13C	CF/CM/CU60D	0.99	1.00	0.97
CPLC120C20MP13C	CF/CM64D	0.99	0.98	0.95