



# I-TEC® I30A1D-I60A1D 2-Stage Compressor High Efficiency Air Source Air Conditioners w/Dehumidification

## Cooling Capacities: 20,600 to 54,000 Btuh

The Bard I-TEC Indoor Air Conditioner system is designed for classrooms and other similar applications demanding high efficiency and the lowest possible sound levels that are practical and achievable, and also accommodates the over-the-window sill requirement for many replacement projects on older school buildings. The I-TEC Series meets that challenge with many innovative design features resulting in a highly refined appearance while at the same time improving on the very important maintenance and serviceability features needed by the facilities maintenance and service staffs.

### I-TEC Standard Features

- All models have dehumidification (hot gas reheat)
- Double wall construction, 20-ga. exterior skin, no visible fasteners
- Non fiberglass insulation
- Hinged, lockable, removable doors
- Removable sides and modularized construction for transporting through standard doors or in elevators allows installation on second and third floor
- Can be installed in left or right corners with no modifications
- Non-corrosive drainpans with no standing water
- 2-Stage scroll compressors with discharge muffler, double floating isolation mounting system, and sound muffling cover for ultra quiet operation
- R-410A Green Refrigerant
- Cooling thermostatic expansion valves
- Extra large full width control panel for easy access to all controls
- Circuit Breakers on 230V models, and Toggle Disconnect on 460V
- Evaporator coils constructed with hydrophilic fin stock with the following advantages:
  - Acrylic coating
  - Wettable surface with low contact angle – no bead-up condensate, lower wet-coil air-side pressure drop, improved draining & lower re-entrainment of moisture back into the air stream in continuous blower operating modes
  - Antimicrobial properties provide microbial resistance to fungicidal growth
  - Resistant to Mold and Mildew, ASTM D3273 – no growth
  - Seals fin surface against aluminum oxide formation
- 24VAC 75VA control transformer with circuit breaker
- 24VAC low-voltage terminal strip for thermostat or DDC control
- ECM indoor and outdoor motors
- Modulating outdoor fan motor and low ambient control
- Modulating indoor fan motor for constant CFM in different operating modes up to 0.50" ESP
- High and Low Pressure switches with lockout circuit
- Liquid line filter/drier
- Readily accessible service ports located behind locking hinged doors
- Pleated 2" MERV 8 filter
- Designed for over-the-window sill wall penetration and has 3" vertical adjustment for wall sleeve attachment



- Units designed to be flush to a smooth interior wall and not require trim kits by use of adjustable wall sleeves; Trim Kits available where required
- Low sound levels are achieved by numerous system design innovations including special acoustical insulation
- Installation flexibility. Can be installed in corner applications with one side against a wall.
- Condensate overflow detection system with diagnostics monitors equipment and shuts down compressor to prevent condensate overflow.
- Freezestat on indoor coil safeguards against indoor coil freeze up by shutting down the compressor.

### I-TEC Optional Features & Accessories

#### Four Ventilation Options:

Both ERV and CRV have ECM motors, filter system, and positive shut-off.

**Energy Recovery Ventilator (ERV)** is designed for both modulating or fixed supply and exhaust airflow operation depending upon environmental controls used, and has positive shutoff on intake and exhaust sides when unoccupied.

- Modulating mode requires CO<sub>2</sub> controller, has intake rate that is higher than exhaust, and has optional minimum CFM to address building IAQ requirements.

The system modulates to maintain selected maximum CO<sub>2</sub> level.

- Fixed mode can be used with thermostat or DDC that has a dedicated Occupied output that is ON during Occupied and OFF during Unoccupied. Intake and exhaust rates can be independently adjusted.

**Commercial Room Ventilator (CRV Option M)** is a fan powered ventilation package to manage intake & exhaust air at fixed rates but without energy recovery capability.

- The rates are: 300-375-450-525 CFM, are independently selectable & has positive shutoff on intake and exhaust sides when unoccupied.
- Requires control system that has a dedicated ventilation control output to be ON during Occupied and OFF during Unoccupied. CO<sub>2</sub> controller with ON/OFF output relay can be used.
- Factory setting is 375 CFM balanced to meet pressurization requirements of ASHRAE.

**Commercial Room Ventilator (CRV Option N)** is same as CRV Option M and also has a free-cooling economizer mode that can provide up to 525 CFM when the outdoor ambient temperature is below the set point of the outdoor thermostat.

**Commercial Room Ventilator (CRV Option Q)** is modulating design that requires 0-10Vdc control signal from CO<sub>2</sub> controller.

#### Other Options:

- Hot water coil packages, both Duct-Free and Ducted versions available.

**Accessories:** See Page 12 & 13.

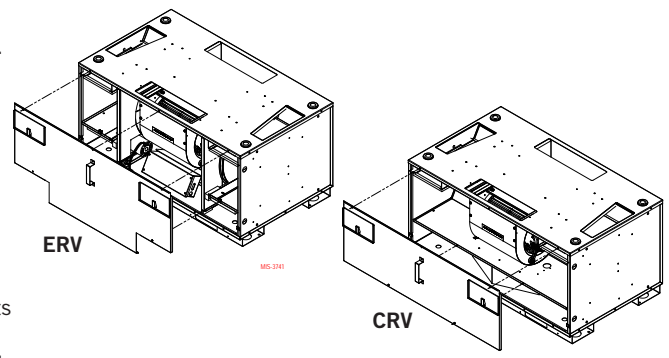

## Specifications - 2½ through 3½ Ton

MODELS	I30A1DA	I30A1DB	I30A1DC	I36A1DA	I36A1DB	I36A1DC	I42A1DA	I42A1DB	I42A1DC
ELECTRICAL RATING--60 HZ	230/208 - 1	230/208 - 3	460 - 3	230/208 - 1	230/208 - 3	460 - 3	230/208 - 1	230/208 - 3	460 - 3
Operating Voltage Range	197-253		414-506	197-253		414-506	197-253		414-506
COMPRESSOR									
Volts	230/208-1	230/208-3	460-3	230/208-1	230/208-3	460-3	230/208-1	230/208-3	460-3
Rated Load Amps (230/208)	10.0/11.5	7.4/8.4	4.2	11.1/13	8.5/9.9	4.9	13.8/15.6	11.0/12.4	5.5
Branch Circuit Selection Current	13.1	8.7	4.3	15.3	11.7	5.8	18.0	14.2	6.3
Locked Rotor Amps	73	58	28	83	73	38	96	88	44
ENERGY RECOVERY VENTILATOR									
Volts	230/208-60-1			230/208-60-1			230/208-60-1		
Full Load Amps (3-motors)	2.2			2.2			2.2		
FAN MOTOR – ECM									
Horsepower	1/3			1/3			1/3		
Volts	230/208-60-1			230/208-60-1			230/208-60-1		
Full Load Amps	1.7			2.6			2.6		
+ CFM	1950			2300			2300		
BLOWER MOTOR – ECM									
Horsepower	1/3			1/2			1/2		
Volts	230/208-60-1			230/208-60-1			230/208-60-1		
Full Load Amps	1.9			2.5			2.5		

+ CFM @ rating points, will modulate based upon O.D. ambient.

## Specifications - 4 and 5 Ton

MODELS	I48A1DA	I48A1DB	I48A1DC	I60A1DA	I60A1DB	I60A1DC
ELECTRICAL RATING--60 HZ	230/208 - 1	230/208 - 3	460 - 3	230/208 - 1	230/208 - 3	460 - 3
Operating Voltage Range	197-253		414-506	197-253		414-506
COMPRESSOR						
Volts	230/208-1	230/208-3	460-3	230/208-1	230/208-3	460-3
Rated Load Amps (230/208)	15.6/17.5	10.4/11.6	5.4	22/23.4	13.4/14.3	6.3
Branch Circuit Selection Current	19.9	11.6	6.4	27.2	16.6	7.2
Locked Rotor Amps	104.0	83.1	41	152.9	110.0	52.0
ENERGY RECOVERY VENTILATOR						
Volts	230/208-60-1			230/208-60-1		
Full Load Amps (3-motors)	2.2			2.2		
FAN MOTOR – ECM						
Horsepower	1/2			1/2		
Volts	230/208-60-1			230/208-60-1		
Full Load Amps	3.2			3.2		
+ CFM	2600			2600		
BLOWER MOTOR – ECM						
Horsepower	1/2			3/4		
Volts	230/208-60-1			230/208-60-1		
Full Load Amps	3.2			4.4		

+ CFM @ rating points, will modulate based upon O.D. ambient.

- Complies with efficiency requirements of ANSI/ASHRAE/IESNA 90.1-2013.
- Certified to ANSI/ARI Standard 390-2003 for SPVU (Single Package Vertical Units).
- Intertek ETL Listed to Standard for Safety Heating and Cooling Equipment ANSI/UL 1995/CSA 22.2 No. 236-05, Fourth Edition.
- Intertek ETL Listed to Standard for Gas-Fired Central Furnaces ANSI Z21.47-2006, CSA 2.3-2006 Fifth Edition, Addenda A dated 10-01-2007, Addenda B dated 06-01-2008.
- Commercial Product - Not intended for Residential application.

\* The AHRI Certified® mark indicates Bard Manufacturing Company participation in the AHRI Certification program. For verification of individual certified products, go to [www.ahridirectory.org](http://www.ahridirectory.org).



Globally Recognized. Industry Respected.



Intertek

Intertek

## Capacity and Efficiency Ratings (Stage 2) Full Load Operation

MODELS	I30A1	I36A1	I42A1	I48A1	I60A1
Cooling BTUH, Full Load Capacity, 95-80/67	27,800	35,000	41,500	47,000	54,000
EER ①	11.7	12.0	11.9	11.3	11.0
Rated CFM	900	1150	1300	1500	1700
IPLV (Integrated Full & Part Load) ② 80-80/67	15.4	16.5	16.0	16.1	15.1

## Capacity and Efficiency Ratings (Stage 1) Part Load Operation

MODELS	I30A1	I36A1	I42A1	I48A1	I60A1
Cooling BTUH, Part Load Capacity, 95-80/67	20,600	25,000	29,000	32,500	37,000
EER ①	11.8	12.7	12.1	12.0	11.0
Rated CFM	650	850	950	1050	1200

① EER = Energy Efficiency Ratio - BTU/WATT efficiency

② IPLV = Integrated Part Load Value - BTU/WATT efficiency (combines full and part load performance)

## Indoor Blower Performance ①

Model	Rated ESP.	Max. ESP	② Continuous CFM	Rated 2nd Stage CFM	Rated 1st Stage CFM	4-10 KW CFM	15-20 KW CFM
I30A1	0.15	0.50	500	900	650	700	1050
I36A1	0.15	0.50	600	1150	850	700	1050
I42A1	0.20	0.50	650	1300	950	700	1050
I48A1	0.20	0.50	725	1500	1050	700	1400
I60A1	0.20	0.50	850	1700	1200	700	1400

① Motor will deliver consistent CFM through voltage supply range with no deterioration.

② Continuous fan CFM is the total air being circulated during continuous fan mode.

## Unit Weights

MODELS	NO VENT	CRV	ERV
I30A1DA	830	920	955
I30A1DB	830	920	955
I30A1DC	865	955	990
I36A1DA	858	950	985
I36A1DB	858	950	985
I36A1DC	893	985	1020
I42A1DA	908	1000	1035
I42A1DB	908	1000	1035
I42A1DC	943	1035	1070
I48A1DA	930	1022	1057
I48A1DB	930	1022	1057
I48A1DC	965	1057	1092
I60A1DA	943	1035	1070
I60A1DB	943	1035	1070
I60A1DC	978	1070	1105

Deduct 49# from all values for installed weight.

## Unit Charge Rates

UNIT	Std. Unit - Lbs.	Dehum. Units - Lbs.
I30A1D - High Efficiency Indoor A/C, Dehum. Only	N/A	8.6250
I36A1D - High Efficiency Indoor A/C, Dehum. Only	N/A	11.2500
I42A1D - High Efficiency Indoor A/C, Dehum. Only	N/A	11.1875
I48A1D - High Efficiency Indoor A/C, Dehum. Only	N/A	13.8125
I60A1D - High Efficiency Indoor A/C, Dehum. Only	N/A	13.3125

### Factory Built-in Electric Heat Table

Model	Voltage	Phase	KW		Amps		BTUH	
			240	208	240	208	240	208
DA04	240/208	1	4	3	16.7	14.4	13,652	10,239
DA05	240/208	1	5.00	3.75	20.8	18.0	17,065	12,799
DA10	240/208	1	10.00	7.50	41.7	36.1	34,130	25,598
DA15	240/208	1	15.00	11.25	62.5	54.1	51,195	38,396
DA20	240/208	1	20.00	15.00	83.3	72.1	68,260	51,195
DB06	240/208	3	6.00	4.50	14.4	12.5	20,478	15,359
DB09	240/208	3	9.00	6.75	21.7	18.7	30,717	23,038
DB15	240/208	3	15.00	11.25	36.1	31.2	51,195	38,396
DB18	240/208	3	18.00	13.50	43.3	37.5	61,434	46,076

Model	Voltage	Phase	KW		Amps		BTUH	
			480V	460V	480V	460V	480V	460V
DC06	480	3	6.00	5.52	7.2	6.9	20,478	18,840
DC09	480	3	9.00	8.28	10.8	10.4	30,717	28,260
DC15	480	3	15.00	13.80	18.0	17.3	51,195	47,099
DC18	480	3	18.00	16.56	21.7	20.8	61,434	56,519

**NOTE:** Not all KW's available in all models. See Minimum Circuit Ampacity and Maximum Overcurrent Protection table on following page.

### Optional IHWC Hot Water Coil Performance - Heating Capacity @ 180°F Water & 70°F Return Air

GPM	CFM									
	800	900	1000	1100	1200	1300	1400	1500	1600	1700
1.5	32,000	32,667	33,333	34,000	34,500	35,000	35,500	36,000	36,400	36,750
2	42,000	43,200	44,400	45,600	46,400	47,200	48,000	48,500	49,000	49,500
3	49,000	51,667	53,750	57,000	59,400	61,750	64,000	65,200	66,000	67,000
4	56,000	59,000	62,000	65,000	69,000	73,000	77,000	79,500	82,000	84,000
5	59,000	62,583	66,167	69,750	72,833	75,917	79,000	81,000	83,000	85,000
6	62,000	66,167	70,333	74,500	77,000	79,500	82,000	83,500	85,000	86,500
7	63,500	67,708	71,917	76,125	78,917	81,708	84,500	86,500	88,000	89,200
8	65,000	69,250	73,500	77,750	80,833	83,917	87,000	88,900	90,500	91,750
9	66,000	70,525	75,050	79,575	82,883	86,192	89,500	91,500	93,000	94,500
10	67,000	71,800	76,600	81,400	84,933	88,467	92,000	94,500	96,000	97,500

### Hot Water Coil Correction Factors

Entering Air Temp (F)	Entering Water Temperature (F)										
	100	110	120	130	140	150	160	170	180	190	200
50	0.455	0.545	0.636	0.727	0.818	0.909	1.000	1.091	1.182	1.273	1.364
55	0.409	0.500	0.591	0.682	0.773	0.864	0.955	1.045	1.136	1.227	1.318
60	0.363	0.455	0.545	0.636	0.727	0.818	0.909	1.000	1.091	1.182	1.273
65	0.318	0.409	0.500	0.591	0.682	0.773	0.864	0.955	1.045	1.136	1.227
70	0.272	0.363	0.455	0.545	0.636	0.727	0.818	0.909	1.000	1.091	1.182
75	0.227	0.318	0.409	0.500	0.591	0.682	0.773	0.864	0.955	1.045	1.136
80	0.182	0.272	0.363	0.455	0.545	0.636	0.727	0.818	0.909	1.000	1.091

## Minimum Circuit Ampacity & Maximum Overcurrent Protection

MODEL	Rated Volts, Hertz & Phase	Single Circuit					Dual Circuit							
		No. Field Power Circuits	① Minimum Circuit Ampacity	② Maximum External Fuse or Ckt. Brkr.	③ Field Power Wire Size	③ Ground Wire	① Minimum Circuit Ampacity		② Maximum External Fuse or Ckt. Breaker		③ Field Power Wire Size		③ Ground Wire Size	
							Ckt. A	Ckt. B	Ckt. A	Ckt. B	Ckt. A	Ckt. B	Ckt. A	Ckt. B
I30A1DA0Z A05 A10	230/208-1	1 1 1	22 32 58	35 35 60	8 8 6	10 10 10								
I30A1DB0Z B06 B09	230/208-3	1 1 1	17 23 32	25 25 35	10 10 10	10 10 10								
I30A1DC0Z C06 C09	460-3	1 1 1	9 13 18	10 15 20	14 14 12	14 14 12								
I36A1DA0Z A05 A10 A15	230/208-1	1 1 1 1 or 2	26 32 58 84	40 40 60 90	8 8 6 4	10 10 10 8	26	52	40	60	8	6	10	10
I36A1DB0Z B06 B09 B15	230/208-3	1 1 1 1	22 23 32 51	30 30 35 60	10 10 8 6	10 10 10 10								
I36A1DC0Z C06 C09 C15	460-3	1 1 1 1	11 13 18 28	15 15 20 30	14 14 12 10	14 14 12 10								
I42A1DA0Z A05 A10 A15	230/208-1	1 1 1 1 or 2	30 32 58 84	45 40 60 90	8 8 6 4	10 10 10 8	30	52	40	60	6	6	10	10
I42A1DB0Z B06 B09 B15	230/208-3	1 1 1 1	25 25 32 52	35 35 35 60	8 8 8 6	10 10 10 10								
I42A1DC0Z C06 C09 C15	460-3	1 1 1 1	12 14 19 28	15 15 20 30	14 14 12 10	14 14 12 10								
I48A1DA0Z A05 A10 A15 A20	230/208-1	1 1 1 1 or 2 1 or 2	34 34 59 85 110	50 50 60 90 110	8 8 6 3 2	10 10 10 8 6	35 59	52 52	45 60	60 60	8 6	6 6	10 10	10 10
I48A1DB0Z B06 B09 B15 B18	230/208-3	1 1 1 1 1	26 26 34 53 53	35 35 35 60 60	8 8 8 6 6	10 10 10 10 10								
I48A1DC0Z C06 C09 C15 C18	460-3	1 1 1 1 1	12 14 19 29 33	15 15 20 30 35	12 12 12 10 8	12 12 12 10 10								
I60A1DA0Z A05 A10 A15 A20	230/208-1	1 1 1 1 or 2 1 or 2	44 44 59 96 112	60 60 60 100 120	8 6 6 3 2	10 10 10 8 6	44 60	52 52	60 60	60 60	8 6	6 6	10 10	10 10
I60A1DB0Z B06 B09 B15 B18	230/208-3	1 1 1 1 1 or 2	31 31 35 53 53	45 45 45 60 60	8 8 8 6 6	10 10 10 10 8	31	54	45	60	8	6	10	10
I60A1DC0Z C06 C09 C15 C18	460-3	1 1 1 1 1	15 15 19 29 33	20 20 20 30 35	12 12 12 10 10	12 12 12 10 10								

① These "Minimum Circuit Ampacity" values are to be used for sizing the field power conductors. Refer to the National Electric Code (latest revision), Article 310 for power conductor sizing.

**Caution:** When more than one field power conductor circuit is run through one conduit, the conductors must be derated. Pay special attention to note 8 of table 310 regarding Ampacity Adjustment Factors when more than three (3) current carrying conductors are in a raceway.

② Maximum size of the time delay fuse or HVAC type circuit breaker for protection of field wiring conductors.

③ Based on 75°C copper wire. All wiring must conform to the National Electrical Code and all local codes.

## Cooling Full Load Application Data

Model	D.B. / W.B. ①	COOLING CAPACITY	60°F	65°F	70°F	75°F	80°F	85°F	90°F	95°F	100°F	105°F	110°F	115°F	120°F	125°F
130A1	75/62	Total Cooling	30,764	30,056	29,349	28,641	27,934	27,226	26,519	25,812	24,976	24,140	23,305	22,469	21,633	20,798
		Sensible Cooling	23,517	23,129	22,741	22,352	21,964	21,575	21,187	20,799	20,596	20,393	20,191	19,988	19,785	19,583
	80/67	Total Cooling	33,488	32,675	31,863	31,050	30,200	29,388	28,613	27,800	26,900	26,000	25,100	24,200	23,300	22,400
		Sensible Cooling	23,981	23,488	22,994	22,500	22,000	21,506	21,019	20,525	20,325	20,125	19,925	19,725	19,525	19,325
	85/72	Total Cooling	35,990	35,372	34,754	34,136	33,518	32,900	32,282	31,664	30,639	29,614	28,589	27,564	26,539	25,514
		Sensible Cooling	23,806	23,272	22,738	22,204	21,671	21,137	20,603	20,069	19,873	19,678	19,482	19,287	19,091	18,896
136A1	75/62	Total Cooling	39,013	38,161	37,310	36,459	35,608	34,756	33,905	33,054	31,800	30,547	29,293	28,040	26,787	25,533
		Sensible Cooling	30,182	29,782	29,383	28,983	28,584	28,184	27,785	27,385	26,853	26,321	25,789	25,257	24,725	24,193
	80/67	Total Cooling	42,469	41,488	40,506	39,525	38,500	37,519	36,581	35,000	34,250	32,900	31,550	30,200	28,850	27,500
		Sensible Cooling	30,788	30,250	29,713	29,175	28,600	28,063	27,563	27,025	26,500	25,975	25,450	24,925	24,400	23,875
	85/72	Total Cooling	45,632	44,906	44,180	43,454	42,727	42,001	41,275	40,548	39,011	37,473	35,935	34,398	32,860	31,323
		Sensible Cooling	30,567	29,975	29,384	28,792	28,200	27,608	27,016	26,424	25,911	25,398	24,884	24,371	23,858	23,344
142A1	75/62	Total Cooling	46,865	45,740	44,616	43,492	42,368	41,244	40,120	38,996	38,006	37,015	36,025	35,035	34,045	33,054
		Sensible Cooling	35,042	34,686	34,331	33,975	33,620	33,264	32,909	32,553	32,198	31,843	31,488	31,133	30,778	30,423
	80/67	Total Cooling	51,013	49,725	48,438	47,150	44,500	43,213	43,288	41,500	40,933	39,867	38,800	37,734	36,667	35,601
		Sensible Cooling	35,756	35,238	34,719	34,200	32,675	32,156	32,644	32,125	31,775	31,424	31,074	30,723	30,373	30,022
	85/72	Total Cooling	54,835	53,836	52,836	51,836	50,837	49,837	48,838	47,838	46,623	45,408	44,194	42,979	41,764	40,549
		Sensible Cooling	35,505	34,921	34,336	33,751	33,166	32,581	31,996	31,411	31,068	30,726	30,383	30,040	29,698	29,355
148A1	75/62	Total Cooling	51,843	50,512	49,180	47,849	46,517	45,185	43,854	42,522	40,910	39,299	37,687	36,076	34,464	32,852
		Sensible Cooling	39,521	38,811	38,101	37,391	36,681	35,971	35,261	34,551	33,856	33,161	32,466	31,771	31,076	30,381
	80/67	Total Cooling	56,913	55,497	54,081	52,664	51,000	49,584	48,416	47,000	45,219	43,437	41,656	39,875	38,093	36,312
		Sensible Cooling	38,814	38,219	37,624	37,029	35,950	35,355	35,245	34,650	33,953	33,256	32,559	31,862	31,165	30,467
	85/72	Total Cooling	56,446	54,927	53,408	51,889	50,369	48,850	47,331	45,811	44,075	42,339	40,603	38,866	37,130	35,394
		Sensible Cooling	38,516	37,839	37,161	36,484	35,806	35,129	34,451	33,774	33,094	32,415	31,735	31,056	30,376	29,697
160A1	75/62	Total Cooling	61,062	59,318	57,575	55,831	54,087	52,343	50,599	48,855	47,366	45,877	44,387	42,898	41,409	39,919
		Sensible Cooling	45,691	44,741	43,790	42,840	41,890	40,939	39,989	39,039	38,482	37,926	37,370	36,813	36,257	35,701
	80/67	Total Cooling	67,038	65,175	63,313	61,450	59,588	57,725	55,863	54,000	52,354	50,708	49,062	47,415	45,769	44,123
		Sensible Cooling	44,881	44,063	43,244	42,425	41,606	40,788	39,969	39,150	38,592	38,034	37,476	36,918	36,360	35,802
	85/72	Total Cooling	72,834	70,739	68,644	66,550	64,455	62,360	60,265	58,170	56,397	54,624	52,851	51,077	49,304	47,531
		Sensible Cooling	44,530	43,620	42,710	41,800	40,890	39,980	39,070	38,160	37,616	37,072	36,528	35,985	35,441	34,897

## Cooling Part Load Application Data

Model	D.B. / W.B. ①	COOLING CAPACITY	60°F	65°F	70°F	75°F	80°F	85°F	90°F	95°F	100°F	105°F	110°F	115°F	120°F	125°F
130A1	75/62	Total Cooling	24,111	23,363	22,615	21,868	21,120	20,372	19,625	18,877	18,212	17,548	16,884	16,219	15,555	14,891
		Sensible Cooling	18,256	17,908	17,561	17,214	16,866	16,519	16,172	15,825	15,526	15,227	14,929	14,630	14,332	14,033
	80/67	Total Cooling	26,025	25,250	24,475	23,700	22,800	22,025	21,375	20,600	19,875	19,150	18,425	17,700	16,975	16,250
		Sensible Cooling	18,000	17,700	17,400	17,100	16,675	16,375	16,200	15,900	15,600	15,300	15,000	14,700	14,400	14,100
	85/72	Total Cooling	27,267	26,729	26,190	25,652	25,113	24,575	24,037	23,498	22,671	21,844	21,017	20,190	19,363	18,536
		Sensible Cooling	17,242	17,056	16,869	16,683	16,497	16,310	16,124	15,938	15,637	15,336	15,036	14,735	14,434	14,133
136A1	75/62	Total Cooling	29,645	28,683	27,720	26,758	25,796	24,833	23,871	22,909	22,233	21,557	20,881	20,206	19,530	18,854
		Sensible Cooling	23,790	23,242	22,694	22,146	21,599	21,051	20,503	19,955	19,743	19,532	19,321	19,109	18,898	18,686
	80/67	Total Cooling	32,000	31,000	30,000	29,000	27,600	26,600	26,000	25,000	24,263	23,525	22,788	22,050	21,313	20,575
		Sensible Cooling	23,463	22,975	22,488	22,000	21,175	20,688	20,538	20,050	19,838	19,625	19,413	19,200	18,988	18,775
	85/72	Total Cooling	33,542	32,824	32,106	31,388	30,670	29,953	29,235	28,517	27,676	26,835	25,993	25,152	24,311	23,470
		Sensible Cooling	22,488	22,146	21,805	21,463	21,122	20,780	20,439	20,098	19,885	19,672	19,459	19,246	19,033	18,819
142A1	75/62	Total Cooling	30,064	29,631	29,198	28,765	28,332	27,899	27,465	27,032	26,091	25,150	24,209	23,268	22,327	21,386
		Sensible Cooling	25,169	24,766	24,362	23,958	23,555	23,151	22,747	22,344	22,055	21,767	21,479	21,191	20,903	20,615
	80/67	Total Cooling	32,431	32,013	31,594	31,175	32,000	31,581	29,919	29,000	28,473	27,446	26,419	25,392	24,365	23,338
		Sensible Cooling	24,813	24,475	24,138	23,800	23,600	23,263	22,788	22,450	22,160	21,871	21,581	21,292	21,002	20,713
	85/72	Total Cooling	33,811	33,788	33,765	33,742	33,719	33,696	33,673	33,650	32,479	31,307	30,136	28,964	27,793	26,622
		Sensible Cooling	23,757	23,578	23,399	23,220	23,040	22,861	22,682	22,503	22,213	21,923	21,633	21,342	21,052	20,762
148A1	75/62	Total Cooling	36,489	35,477	34,465	33,453	32,441	31,429	30,417	29,405	28,404	27,403	26,402	25,401	24,400	23,399
		Sensible Cooling	27,440	26,922	26,404	25,886	25,369	24,851	24,333	23,815	23,512	23,210	22,907	22,604	22,302	21,999
	80/67	Total Cooling	40,380	39,255	38,129	37,003	36,000	34,874	33,626	32,500	31,394	30,288	29,181	28,075	26,969	25,863
		Sensible Cooling	27,189	26,712	26,234	25,756	25,241	24,763	24,323	23,845	23,542	23,239	22,936	22,633	22,330	22,027
	85/72	Total Cooling	37,194	36,987	36,780	36,573	36,366	36,159	35,952	35,745	34,529	33,312	32,095	30,879	29,662	28,445
		Sensible Cooling	26,876	26,403	25,930	25,457	24,984	24,511	24,038	23,565	23,265	22,966	22,666	22,367	22,067	21,768
160A1	75/62	Total Cooling	42,805	41,472	40,139	38,807	37,474	36,142	34,809	33,476	32,487	31,497	30,508	29,518	28,528	27,539
		Sensible Cooling	31,549	30,890	30,232	29,574	28,916	28,258	27,599	26,941	26,585	26,230	25,874	25,518	25,162	24,806
	80/67	Total Cooling	47,369	45,888	44,406	42,925	41,000	39,519	38,481	37,000	35,906	34,813	33,719	32,625	31,531	30,438
		Sensible Cooling	31,263	30,650	30,038	29,425	28,500	27,888	27,588	26,975	26,619	26,263	25,906	25,550	25,194	24,838
	85/72	Total Cooling	51,941	50,334	48,728	47,121	45,515	43,908	42,301	40,695	39,492	38,289	37,086	35,883	34,680	33,477
		Sensible Cooling	30,902	30,296	29,690	29,083	28,477	27,870	27,264	26,658	26,306	25,954	25,602	25,250	24,897	24,545

① Return air temp. °F Rated CFM.

## DEHUMIDIFICATION CIRCUIT

The I\*\*A models with hot gas dehumidification provide a unique circuit for periods of high indoor humidity conditions. Additionally, an “energy recovery ventilator” may be provided to allow for outside ventilation air requirements by eliminating excessive sensible and latent loads as a result of the increased ventilation requirement.

The dehumidification circuit incorporates an independent heat exchanger coil in the supply air stream in addition to the standard evaporator coil. This coil reheats the supply air after it passes over the cooling coil, and is sized to nominally match the sensible cooling capacity of the evaporator coil. Extended run times in dehumidification mode can be achieved using waste heat from the refrigeration cycle to achieve the reheat process, while at the same time large amounts of moisture can be extracted from the passing air stream. See below for specific operating sequences, and see attached tables for performance on sensible and latent capacities, water removal ratings, and supply air delivery conditions.

The dehumidification refrigerant reheat circuit is controlled by a 3-way valve directing the refrigerant gas to the normal condenser during periods when standard air conditioning is required. During periods of time of low ambient temperature (approximately 65° to 75° outdoor) and high indoor humidity, a humidistat senses the need for mechanical dehumidification. It then energizes both the compressor circuit and the 3-way valve, thus directing the hot refrigerant discharge gas into a separate desuperheating condenser circuit which reheats the conditioned air before it is delivered to the room. The refrigerant gas is then routed from the desuperheating condenser to the outdoor coils for further heat transfer. When the humidistat is satisfied, the system automatically switches back to normal A/C mode and either continues to operate or turns off based on the signal from the wall thermostat. The result is separate humidity control at minimum operating cost.

## DEHUMIDIFICATION SEQUENCE OF OPERATION

Dehumidification is controlled through a humidistat and is independent of the thermostat. On a call for dehumidification mode of operation, the compressor will operate at full load (capacity) and 3-way valve that feeds the reheat coil is energized through “D” terminal. Dehumidification will continue until the humidistat is satisfied.

Anytime there is a R-Y call for cooling, dehumidification is canceled and the unit will operate in the cooling mode at part load for Stage 1 cooling (can shift to full load if 2nd Stage cooling required) until satisfied. If dehumidification call is still present when cooling call is satisfied, the unit will continue to operate and revert to dehumidification mode with compressor at full level.

## DEHUMIDIFICATION RELAY LOGIC BOARD

		Inputs to Board									Outputs From Board								
		G	Y	B	W2	E1	A1	D	RAT	L	G1	BK	YO	RV	W	E	A2	TWV	L
Cooling Mode	Unoccupied	X	X								X		X						
Cooling Mode	Occupied	X	X				X				X		X						
Cooling Mode	w/Dehum	X	X				X				X		X						
Dehumidification	Unoccupied						X				X		X					X	
Dehumidification	Occupied						X	X			X		X					X	

**NOTE:** Cooling takes precedence over dehumidification. A cooling call cancels dehumidification.

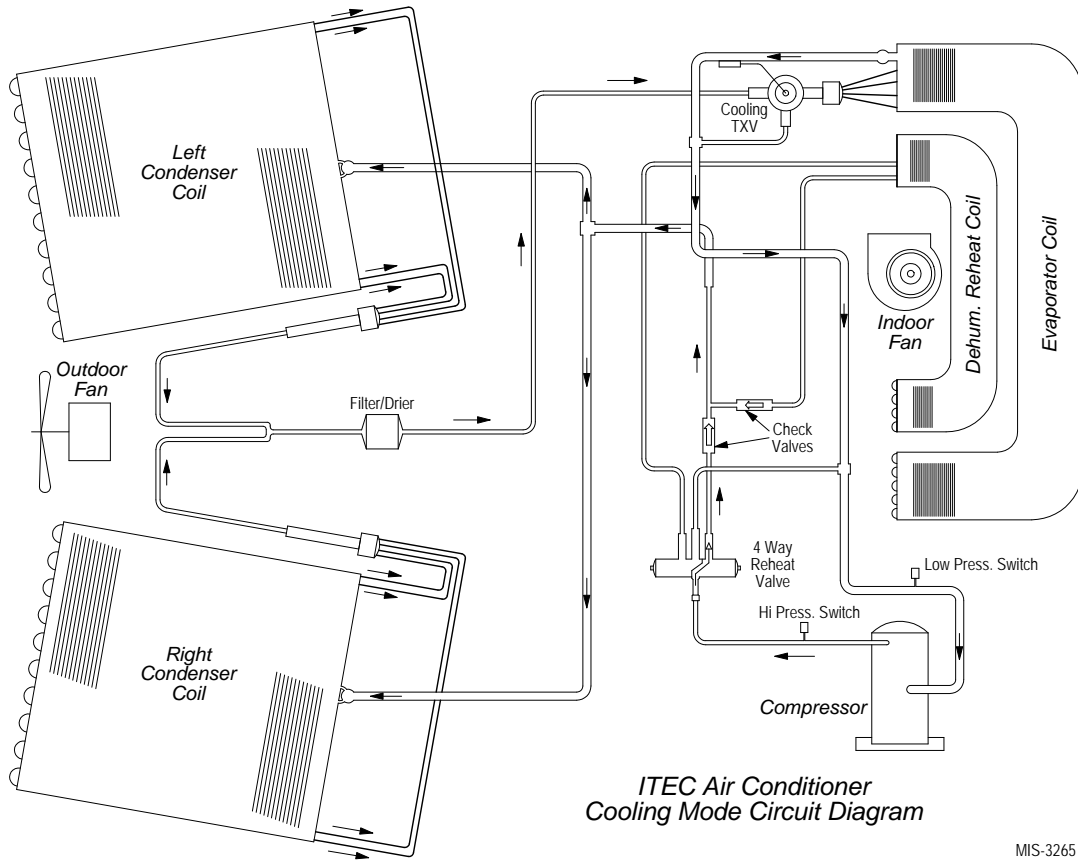

*ITEC Air Conditioner  
Cooling Mode Circuit Diagram*

MIS-3265

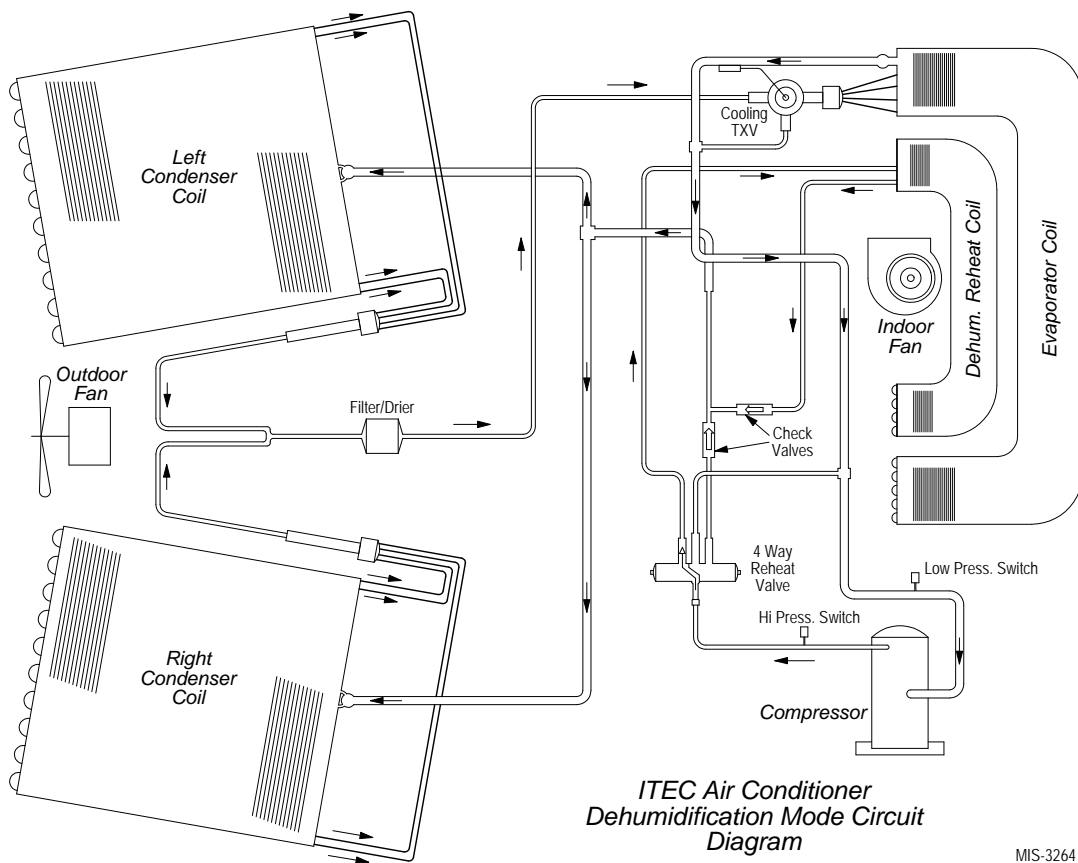

*ITEC Air Conditioner  
Dehumidification Mode Circuit Diagram*

MIS-3264



### I30A1D APPLICATION PERFORMANCE DATA

Indoor Conditions °F		Outdoor Conditions °F	System Capacity				Pounds of Water/Hour	Evaporator Airflow	Approximate Supply Air		Mode
DB/WB	%RH	DB	Total	Sensible	Latent	S/T	Lbs.	CFM	DB	WB	A/C vs. Dehum
65/63	90	65	31,375	13,550	17,825	43.2%	16.8	850	50.7	50.3	A/C
65/63	90	65	15,025	(1,150)	16,175	N/A	15.3	850	66.3	57.3	Dehum
75/62.5	50	75	28,125	21,600	6,525	76.8%	6.2	850	52.0	51.0	A/C
75/62.5	50	75	8,900	3,650	5,250	N/A	5.0	850	71.1	58.9	Dehum
75/65.5	60	75	30,700	19,250	11,450	62.7%	10.8	850	54.5	53.5	A/C
75/65.5	60	75	11,400	1,775	9,625	N/A	9.1	850	73.1	61.4	Dehum
75/68	70	75	32,100	16,725	15,375	52.1%	14.5	850	57.1	56.2	A/C
75/68	70	75	13,150	(100)	13,250	N/A	12.5	850	75.1	63.6	Dehum
80/67	50	95	27,575	20,375	7,200	73.9%	6.8	850	58.1	56.7	A/C
80/67	50	95	2,625	(2,975)	5,600	N/A	5.3	850	83.3	66.0	Dehum

### I36A1D APPLICATION PERFORMANCE DATA

Indoor Conditions °F		Outdoor Conditions °F	System Capacity				Pounds of Water/Hour	Evaporator Airflow	Approximate Supply Air		Mode
DB/WB	%RH	DB	Total	Sensible	Latent	S/T	Lbs.	CFM	DB	WB	A/C vs. Dehum
65/63	90	65	39,550	16,550	23,000	41.8%	21.7	1150	51.7	51.2	A/C
65/63	90	65	17,950	(925)	18,875	N/A	17.8	1150	65.7	57.9	Dehum
75/62.5	50	75	36,775	27,750	9,025	75.5	8.5	1150	52.8	51.3	A/C
75/62.5	50	75	11,000	5,025	5,975	45.7%	5.6	1150	70.9	59.3	Dehum
75/65.5	60	75	39,675	24,175	15,500	60.9%	14.6	1150	55.6	54.3	A/C
75/65.5	60	75	13,000	3,075	9,925	23.7%	9.4	1150	72.5	62.0	Dehum
75/68	70	75	41,625	21,300	20,325	51.2%	19.2	1150	57.9	56.8	A/C
75/68	70	75	15,900	1,050	14,850	6.6%	14.0	1150	74.1	64.0	Dehum
80/67	50	95	34,225	25,625	8,600	74.9%	8.1	1150	59.3	57.5	A/C
80/67	50	95	7,625	2,575	5,050	33.8%	4.8	1150	82.8	66.7	Dehum

### I42A1D APPLICATION PERFORMANCE DATA

Indoor Conditions °F		Outdoor Conditions °F	System Capacity				Pounds of Water/Hour	Evaporator Airflow	Approximate Supply Air		Mode
DB/WB	%RH	DB	Total	Sensible	Latent	S/T	Lbs.	CFM	DB	WB	A/C vs. Dehum
65/63	90	65	47,475	18,875	28,600	39.8%	27.0	1300	52.0	51.5	A/C
65/63	90	65	20,175	(1,925)	22,100	N/A	20.8	1300	66.3	58.2	Dehum
75/62.5	50	75	42,775	31,675	11,100	74.1%	10.5	1300	52.7	51.0	A/C
75/62.5	50	75	11,950	5,075	6,875	42.5%	6.5	1300	71.3	59.5	Dehum
75/65.5	60	75	45,750	27,750	18,000	60.7%	17.0	1300	55.4	54.0	A/C
75/65.5	60	75	15,325	2,625	12,700	17.1%	12.0	1300	73.1	62.0	Dehum
75/68	70	75	48,075	24,300	23,775	50.5%	22.4	1300	57.8	56.7	A/C
75/68	70	75	17,675	250	17,425	1.4%	16.4	1300	74.8	64.2	Dehum
80/67	50	95	40,375	29,575	10,800	73.3%	10.2	1300	59.2	57.2	A/C
80/67	50	95	325	(3,900)	4,225	N/A	4.0	1300	82.8	66.8	Dehum

## I48A1D APPLICATION PERFORMANCE DATA

Indoor Conditions °F		Outdoor Conditions °F	System Capacity				Pounds of Water/Hour	Evaporator Airflow	Approximate Supply Air		Mode
DB/WB	%RH	DB	Total	Sensible	Latent	S/T	Lbs.	CFM	DB	WB	A/C vs. Dehum
65/63	90	65	53,525	22,500	31,025	42.0%	29.3	1550	51.1	50.6	A/C
65/63	90	65	20,575	(4,925)	25,500	N/A	24.1	1550	68.0	58.6	Dehum
75/62.5	50	75	50,350	38,125	12,225	75.7%	11.5	1550	51.5	50.5	A/C
75/62.5	50	75	12,800	3,575	9,225	N/A	8.7	1550	72.7	59.7	Dehum
75/65.5	60	75	53,750	32,975	20,775	61.3%	19.6	1550	54.6	53.7	A/C
75/65.5	60	75	15,825	850	14,975	N/A	14.1	1550	74.4	62.3	Dehum
75/68	70	75	55,600	28,750	26,850	51.7%	25.3	1550	57.2	56.4	A/C
75/68	70	75	17,500	(1,875)	19,375	N/A	18.3	1550	76.1	64.7	Dehum
80/67	50	95	49,250	36,350	12,900	73.8%	12.2	1550	57.6	56.4	A/C
80/67	50	95	(850)	(7,300)	6,450	N/A	6.1	1550	84.6	67.2	Dehum

## I60A1D APPLICATION PERFORMANCE DATA

Indoor Conditions °F		Outdoor Conditions °F	System Capacity				Pounds of Water/Hour	Evaporator Airflow	Approximate Supply Air		Mode
DB/WB	%RH	DB	Total	Sensible	Latent	S/T	Lbs.	CFM	DB	WB	A/C vs. Dehum
65/63	90	65	61,000	25,925	35,075	42.5%	33.1	1750	51.4	50.6	A/C
65/63	90	65	18,325	(6,475)	24,800	N/A	23.4	1750	68.6	59.6	Dehum
75/62.5	50	75	58,425	44,475	13,950	76.1%	13.2	1750	52.1	50.8	A/C
75/62.5	50	75	9,100	525	8,575	N/A	8.1	1750	74.8	60.8	Dehum
75/65.5	60	75	62,000	38,625	23,375	62.3%	22.1	1750	55.0	53.9	A/C
75/65.5	60	75	12,150	(1,700)	13,850	N/A	13.1	1750	76.0	63.4	Dehum
75/68	70	75	65,150	33,550	31,600	51.5%	29.8	1750	57.6	56.5	A/C
75/68	70	75	14,950	(4,575)	19,525	N/A	18.4	1750	77.4	65.5	Dehum
80/67	50	95	56,450	42,050	14,400	74.5%	13.6	1750	58.1	56.7	A/C
80/67	50	95	(3,750)	(10,550)	6,800	N/A	6.4	1750	85.6	67.5	Dehum

# Performance and Application Data – Energy Recovery Vent Option "R"

## SUMMER COOLING PERFORMANCE (INDOOR DESIGN CONDITIONS 75°DB/62°WB)

Ambient O.D.	VENTILATION RATE 450 CFM 65% EFFICIENCY							VENTILATION RATE 375 CFM 66% EFFICIENCY							VENTILATION RATE 300 CFM 67% EFFICIENCY						
	DB/WB	F	VLT	VLS	VLL	HRT	HRS	HRL	VLT	VLS	VLL	HRT	HRS	HRL	VLT	VLS	VLL	HRT	HRS	HRL	
105	75		21465	14580	6884	13952	9477	4475	17887	12150	5737	11805	8018	3786	14310	9720	4590	9587	6512	3075	
	70		14580	14580	0	9477	9477	0	12150	12150	0	8018	8018	0	9720	9720	0	6512	6512	0	
	65		14580	14580	0	9477	9477	0	12150	12150	0	8018	8018	0	9720	9720	0	6512	6512	0	
100	80		31590	12150	19440	20533	7897	12635	26325	10125	16200	17374	6682	10692	21060	8100	12960	14110	5427	8683	
	75		21465	12150	9314	13952	7897	6054	17887	10125	7762	11805	6682	5123	14310	8100	6210	9587	5427	4160	
	70		12352	12150	202	8029	7897	131	10293	10125	168	6793	6682	111	8235	8100	135	5517	5427	90	
	65		12150	12150	0	7897	7897	0	10125	10125	0	6682	6682	0	8100	8100	0	5427	5427	0	
	60		12150	12150	0	7897	7897	0	10125	10125	0	6682	6682	0	8100	8100	0	5427	5427	0	
95	80		31590	9720	21870	20533	6318	14215	26325	8100	18225	17374	5345	12028	21060	6480	14580	14110	4341	9768	
	75		21465	9720	11744	13952	6318	7634	17887	8100	9787	11805	5345	6459	14310	6480	7830	9587	4341	5246	
	70		12352	9720	2632	8029	6318	1711	10293	8100	2193	6793	5345	1447	8235	6480	1755	5517	4341	1175	
	65		9720	9720	0	6318	6318	0	8100	8100	0	5345	5345	0	6480	6480	0	4341	4341	0	
	60		9720	9720	0	6318	6318	0	8100	8100	0	5345	5345	0	6480	6480	0	4341	4341	0	
90	80		31590	7290	24300	20533	4738	15794	26325	6075	20250	17374	4009	13365	21060	4860	16200	14110	3256	10854	
	75		21465	7290	14175	13952	4738	9213	17887	6075	11812	11805	4009	7796	14310	4860	9450	9587	3256	6331	
	70		12352	7290	5062	8029	4738	3290	10293	6075	4218	6793	4009	2784	8235	4860	3375	5517	3256	2261	
	65		7290	7290	0	4738	4738	0	6075	6075	0	4009	4009	0	4860	4860	0	3256	3256	0	
	60		7290	7290	0	4738	4738	0	6075	6075	0	4009	4009	0	4860	4860	0	3256	3256	0	
85	80		31590	4860	26730	20533	3159	17374	26325	4050	22275	17374	2672	14701	21060	3240	17820	14110	2170	11939	
	75		21465	4860	16605	13952	3159	10793	17887	4050	13837	11805	2672	9132	14310	3240	11070	9587	2170	7416	
	70		12352	4860	7492	8029	3159	4870	10293	4050	6243	6793	2672	4120	8235	3240	4995	5517	2170	3346	
	65		4860	4860	0	3159	3159	0	4050	4050	0	2672	2672	0	3240	3240	0	2170	2170	0	
	60		4860	4860	0	3159	3159	0	4050	4050	0	2672	2672	0	3240	3240	0	2170	2170	0	
80	75		21465	2430	19035	13952	1579	12372	17887	2025	15862	11805	1336	10469	14310	1620	12690	9587	1085	8502	
	70		12352	2430	9922	8029	1579	6449	10293	2025	8268	6793	1336	5457	8235	1620	6615	5517	1085	4432	
	65		4252	2430	1822	2764	1579	1184	3543	2025	1518	2338	1336	1002	2835	1620	1215	1899	1085	814	
	60		2430	2430	0	1579	1579	0	2025	2025	0	1336	1336	0	1620	1620	0	1085	1085	0	
75	70		12352	0	12352	8029	0	8029	10293	0	10293	6793	0	6793	8235	0	8235	5517	0	5517	
	65		4252	0	4252	2764	0	2764	3543	0	3543	2338	0	2338	2835	0	2835	1899	0	1899	
	60		0	0	0	0	0	0	0	0	0	0	0	0	0	0	0	0	0	0	

## WINTER HEATING PERFORMANCE (INDOOR DESIGN CONDITIONS 70°F DB)

Ambient O.D.	VENTILATION RATE						
	450 CFM 80% EFFICIENCY		375 CFM 81% EFFICIENCY		300 CFM 82% EFFICIENCY		
	DB/°F	WVL	WHR	WVL	WHR	WVL	WHR
65	2430	1944	2025	1640	1620	1328	
60	4860	3888	4050	3280	3240	2656	
55	7290	5832	6075	4920	4860	3985	
50	9720	7776	8100	6561	6480	5313	
45	12150	9720	10125	8201	8100	6642	
40	14580	11664	12150	9841	9720	7970	
35	17010	13608	14175	11481	11340	9298	
30	19440	15552	16200	13122	12960	10627	
25	21870	17496	18225	14762	14580	11955	
20	24300	19440	20250	16402	16200	13284	
15	26730	21384	22275	18042	17820	14612	

**LEGEND:**

- VLT = Ventilation Load - Total
- VLS = Ventilation Load - Sensible
- VLL = Ventilation Load - Latent
- HRT = Heat Recovery - Total
- HRS = Heat Recovery - Sensible
- HRL = Heat Recovery - Latent
- WVL = Winter Ventilation Load
- WHR = Winter Heat Recovery

**NOTE:** Sensible performance only is shown for winter application.

## I-TEC Accessory Model Numbers

### Wall Sleeves (Required Option - Select One) ①

Model #	Description	Total Depth of Wall System When Used with 1" Louver	Total Depth of Wall System When Used with 2" Louver
IWS-A	Wall Sleeve Adjustable	5.5 to 8.5"	6.5 to 8.5"
IWS-B	Wall Sleeve Adjustable	8.0 to 13.5"	9.0 to 13.5"
IWS-C	Wall Sleeve Adjustable	13.0 to 23.5"	14.0 to 23.5"
Model #	Description	Total Depth of Wall System When Used with 4" Louver	Total Depth of Wall System When Used with 8" Louver
IWS-A8H ②	Wall Sleeve Adjustable	8.0 to 12.0"	—
IWS-B8H ②	Wall Sleeve Adjustable	12.0 to 20.0"	12.0 to 15.0"
IWS-C8H ②	Wall Sleeve Adjustable	—	15.0 to 20.5"

① Above table based on I-TEC unit being installed flush to inside of wall.

② 8" Depth Storm Louvers are field supplied

### Outdoor Louver Grilles (Required Option - Select One)

Model #	Description	Color	Sleeve (Required)
ILS1-10	1" Standard	Anodized Aluminum	IWS-A, -B, -C
ILS1-20	1" Standard	Aluminum with Medium Bronze Finish	IWS-A, -B, -C
ILS1-30	1" Standard	Aluminum with Dark Bronze Finish	IWS-A, -B, -C
ILS1-**	1" Standard	Aluminum with Custom Finish	IWS-A, -B, -C
ILA2-10	2" Architectural	Anodized Aluminum	IWS-A, -B, -C
ILA2-20	2" Architectural	Aluminum with Medium Bronze Finish	IWS-A, -B, -C
ILA2-30	2" Architectural	Aluminum with Dark Bronze Finish	IWS-A, -B, -C
ILA2-**	2" Architectural	Aluminum with Custom Finish	IWS-A, -B, -C
ILST4-10	4" Storm	Anodized Aluminum	IWS-AH, -BH, -CH
ILST4-20	4" Storm	Aluminum with Medium Bronze Finish	IWS-AH, -BH, -CH
ILST4-30	4" Storm	Aluminum with Dark Bronze Finish	IWS-AH, -BH, -CH
ILST4-**	4" Storm	Aluminum with Custom Finish	IWS-AH, -BH, -CH

### Additional Louver Colors Available — Applies to ILS, ILA and ILST Louvers ②

-12	Arctic White
-14	Storm White
-18	Milano Beige
-32	Jet Black
-36	Graphite Gray
-40	School Bus Yellow
-42	Florida Orange
-44	School House Red
-46	Chili Red
-50	Deep Sea Blue
-52	Bahama Blue
-54	Ivy Green
-56	Sage Green

② Available Special Order and requires additional lead-time. Reference Form S3508 for additional details.

- Custom Finishes are quoted on a project-by-project basis and pricing is determined by quantity, finish option and size.
- Custom Finishes are ordered/shipped directly from the louver supplier.
- Purchaser of Custom Finishes assumes liability for quantity, finish match and size.
- Contact your Bard Sales Representative for custom louver contact information.

## I-TEC Accessories — Optional per Job Requirement

### Duct-Free Plenum Boxes

<b>Model #:</b>	<b>Description:</b>
IPBDFH18-X	18" Duct Free Plenum – Beige. Black linear slot grilles, side w/shutoff damper
IPBDFH18-1	18" Duct Free Plenum – White. Black linear slot grilles, side w/shutoff damper
IPBDFH18-4	18" Duct Free Plenum – Gray. Black linear slot grilles, side w/shutoff damper
IPBDFH12-X	12" Duct Free Plenum – Beige. Black linear slot grilles, side w/shutoff damper
IPBDFH12-1	12" Duct Free Plenum – White. Black linear slot grilles, side w/shutoff damper
IPBDFH12-4	12" Duct Free Plenum – Gray. Black linear slot grilles, side w/shutoff damper
IPBDF18-X	18" Duct Free Plenum – Beige. (2) Anodized dual deflection front & side grilles
IPBDF18-1	18" Duct Free Plenum – White. (2) Anodized dual deflection front & side grilles
IPBDF18-4	18" Duct Free Plenum – Gray. (2) Anodized dual deflection front & side grilles
IPBDF12-X	12" Duct Free Plenum – Beige. (2) Anodized dual deflection front & side grilles
IPBDF12-1	12" Duct Free Plenum – White. (2) Anodized dual deflection front & side grilles
IPBDF12-4	12" Duct Free Plenum – Gray. (2) Anodized dual deflection front & side grilles
IPBDF8-X	8" Duct Free Plenum – Beige. Anodized dual deflection front & side grilles
IPBDF8-1	8" Duct Free Plenum – White. Anodized dual deflection front & side grilles
IPBDF8-4	8" Duct Free Plenum – Gray. Anodized dual deflection front & side grilles

### Duct-Free Plenum Boxes with Hot Water Coil

<b>Model #:</b>	<b>Description:</b>
IPBDF12HW-X	12" Duct Free Plenum–Beige. Anodized dual deflection front & side grilles, w/hot water coil
IPBDF12HW-1	12" Duct Free Plenum–White. Anodized dual deflection front & side grilles, w/hot water coil
IPBDF12HW-4	12" Duct Free Plenum–Gray. Anodized dual deflection front & side grilles, w/hot water coil

**NOTE:** No water control valves included. Field-Installed.

### Hot Water Coil with Duct Connection

<b>Model #:</b>	<b>Description:</b>
IHW-C	Hot water coil assembly, mounts on top of I-TEC unit, 10" x 30" duct flange

**NOTE:** No water control valves included. Field-Installed.

**NOTE:** Order appropriate Cabinet Extension (Model ICX28-\*) to enclose hot water coil assembly, valves, piping and ductwork.

### Hot Water Coil Valves

<b>Model #:</b>	<b>Description:</b>
5650-035	On/Off Water Valve, 3 way 3/4" 24V
5650-047	Modulating Water Valve, 3 way 3/4" 24V

### Cabinet Extensions

<b>Model #:</b>	<b>Description:</b>
ICX28-X	28" extension for ceilings up to 10'2", beige paint
ICX28-1	28" extension for ceilings up to 10'2", white paint
ICX28-4	28" extension for ceilings up to 10'2", gray paint

### Riser Platforms

<b>Model #:</b>	<b>Description:</b>	<b>Model #:</b>	<b>Description:</b>
IRP-3-X	Riser platform 3" with trim kit, beige paint	IRP-11-X	Riser platform 11" with trim kit, beige paint
IRP-3-1	Riser platform 3" with trim kit, white paint	IRP-11-1	Riser platform 11" with trim kit, white paint
IRP-3-4	Riser platform 3" with trim kit, gray paint	IRP-11-4	Riser platform 11" with trim kit, gray paint
IRP-6-X	Riser platform 6" with trim kit, beige paint	IRP-14-X	Riser platform 14" with trim kit, beige paint
IRP-6-1	Riser platform 6" with trim kit, white paint	IRP-14-1	Riser platform 14" with trim kit, white paint
IRP-6-4	Riser platform 6" with trim kit, gray paint	IRP-14-4	Riser platform 14" with trim kit, gray paint
IRP-9-X	Riser platform 9" with trim kit, beige paint		
IRP-9-1	Riser platform 9" with trim kit, white paint		
IRP-9-4	Riser platform 9" with trim kit, gray paint		

**NOTE:** Use of Riser Platforms will increase maximum ceiling height by riser height.

## I-TEC Accessories — Optional per Job Requirement

### Wall Curbs

<b>Model #:</b>	<b>Description:</b>
ICURB740	7" Deep Curb to allow sleeve installation with a 40" window sill height

### Side Trim Kits

<b>Model #:</b>	<b>Description:</b>
IST4-X	4" Side Trim Kit, beige paint, adaptable for ceilings up to 12'
IST4-1	4" Side Trim Kit, white paint, adaptable for ceilings up to 12'
IST4-4	4" Side Trim Kit, gray paint, adaptable for ceilings up to 12'
IST4L-X	4" Side Trim Kit, beige paint, adaptable for ceilings up to 12' 10"
IST4L-1	4" Side Trim Kit, beige paint, adaptable for ceilings up to 12' 10"
IST4L-4	4" Side Trim Kit, beige paint, adaptable for ceilings up to 12' 10"
IST6-X	6" Side Trim Kit, beige paint, adaptable for ceilings up to 12'
IST6-1	6" Side Trim Kit, white paint, adaptable for ceilings up to 12'
IST6-4	6" Side Trim Kit, gray paint, adaptable for ceilings up to 12'
IST10-X	10" Side Trim Kit, beige paint, adaptable for ceilings up to 12'
IST10-1	10" Side Trim Kit, beige paint, adaptable for ceilings up to 12'
IST10-4	10" Side Trim Kit, beige paint, adaptable for ceilings up to 12'

### Other Optional Accessories

<b>Model #:</b>	<b>Description:</b>
AHCK-2A	Anti-Huffing Refrigerant Caps (Quantity 2) with Key
SK111	Hard Start Kit for 1-Phase Models (I30A1-A, I36A1-A & I42A1-A) Only
SK118	Hard Start Kit for 1-Phase Models (I48A1-A & I60A1-A) Only

**This page intentionally left blank.**

# Unit Specification Sheet

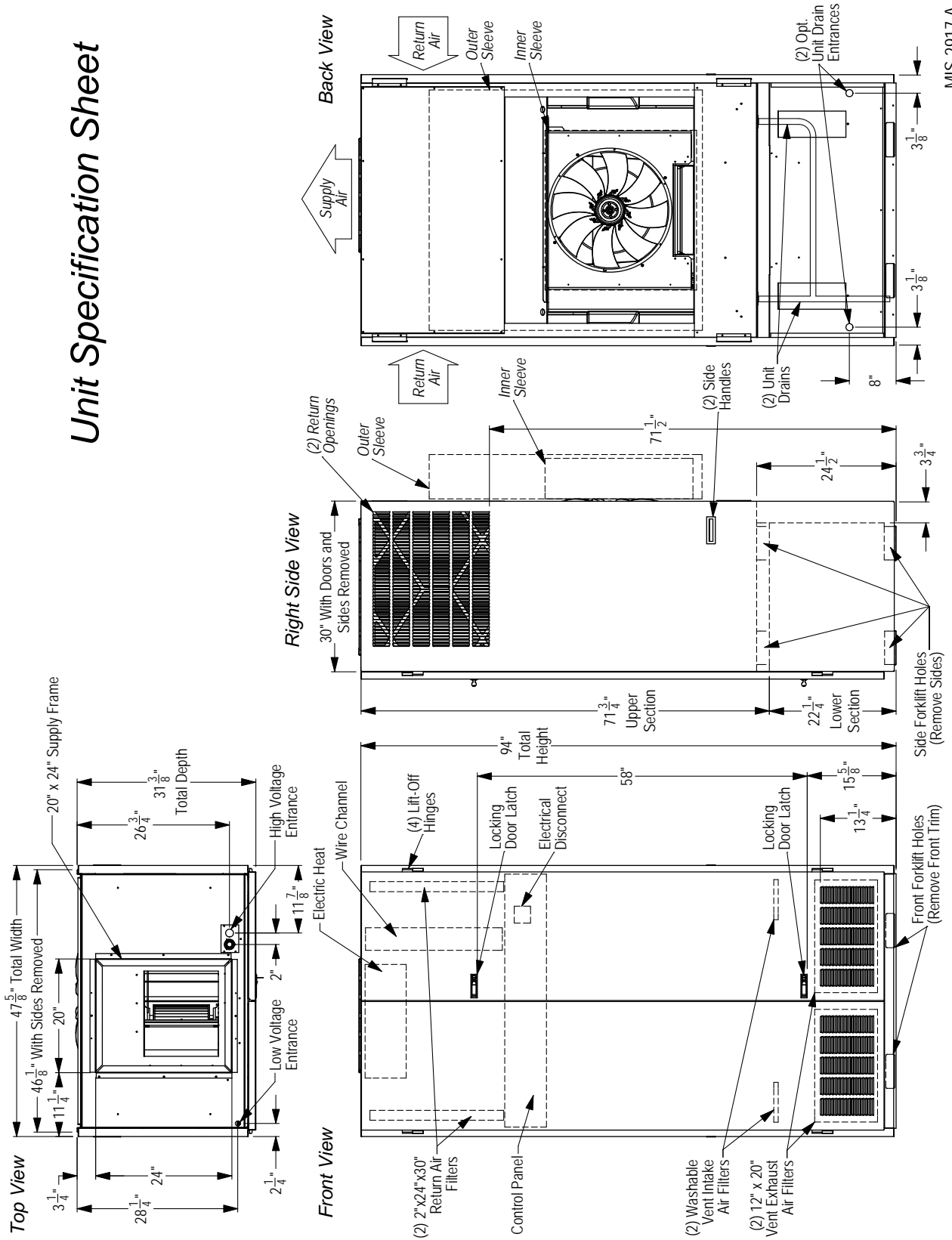

MIS-2917 A



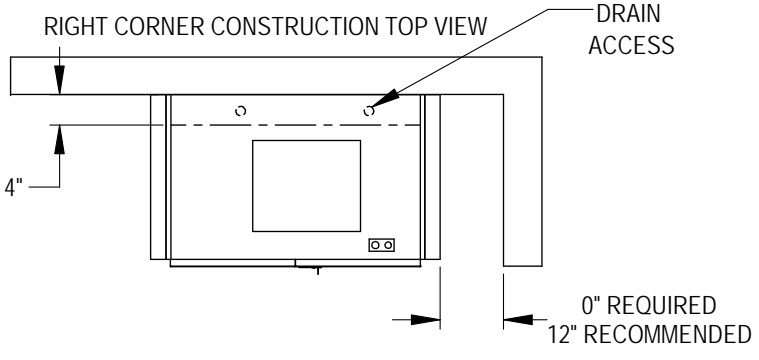
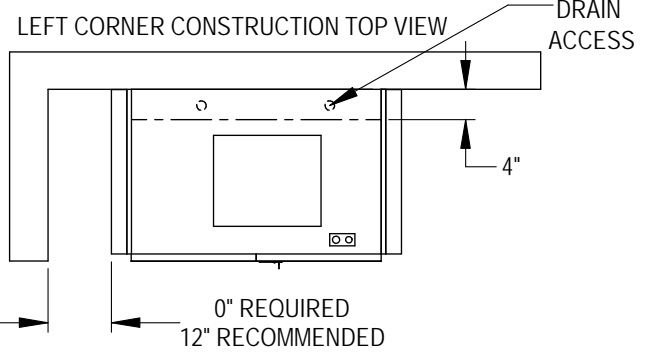
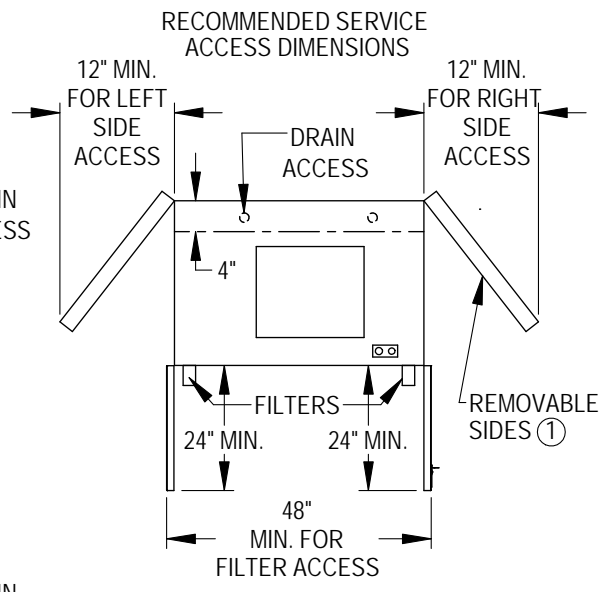
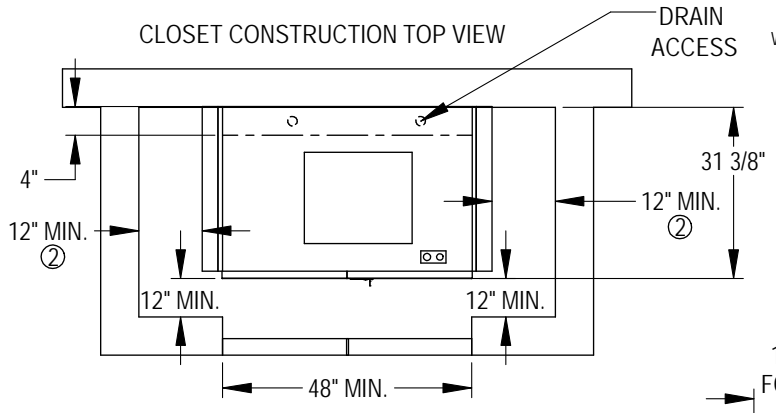
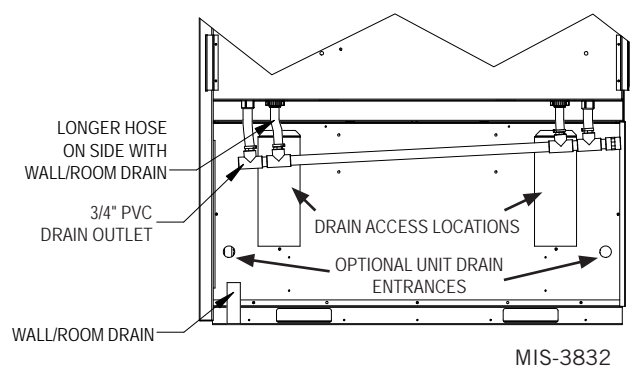
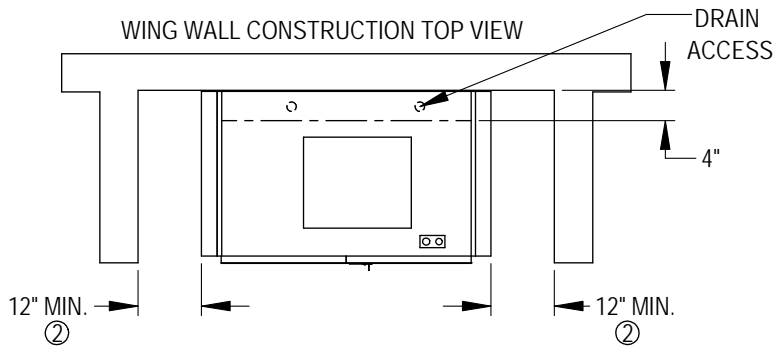

- ① ALL FILTER AND COMPONENT ACCESS IS FROM THE FRONT. COILS CAN BE CLEANED FROM THE FRONT, BUT SIDES ARE EASILY REMOVED FOR ENHANCED ACCESS.
- ② 12" MINIMUM DIMENSIONS ARE REQUIRED FOR UNIT OPERATION. IT IS STRONGLY RECOMMENDED TO USE 20" MINIMUM DISTANCES IF POSSIBLE FOR EASE OF UNIT SERVICEABILITY

MIS-3273 A

# Wall Section View

RISER KIT	DIM A	DIM B	DIM C
NONE	31"-34" MAX	29 17/32"	94 1/8"
IRP-3 (3")	34"-37" MAX	32 17/32"	97 1/8"
IRP-6 (6")	37"-40" MAX	35 17/32"	100 1/8"

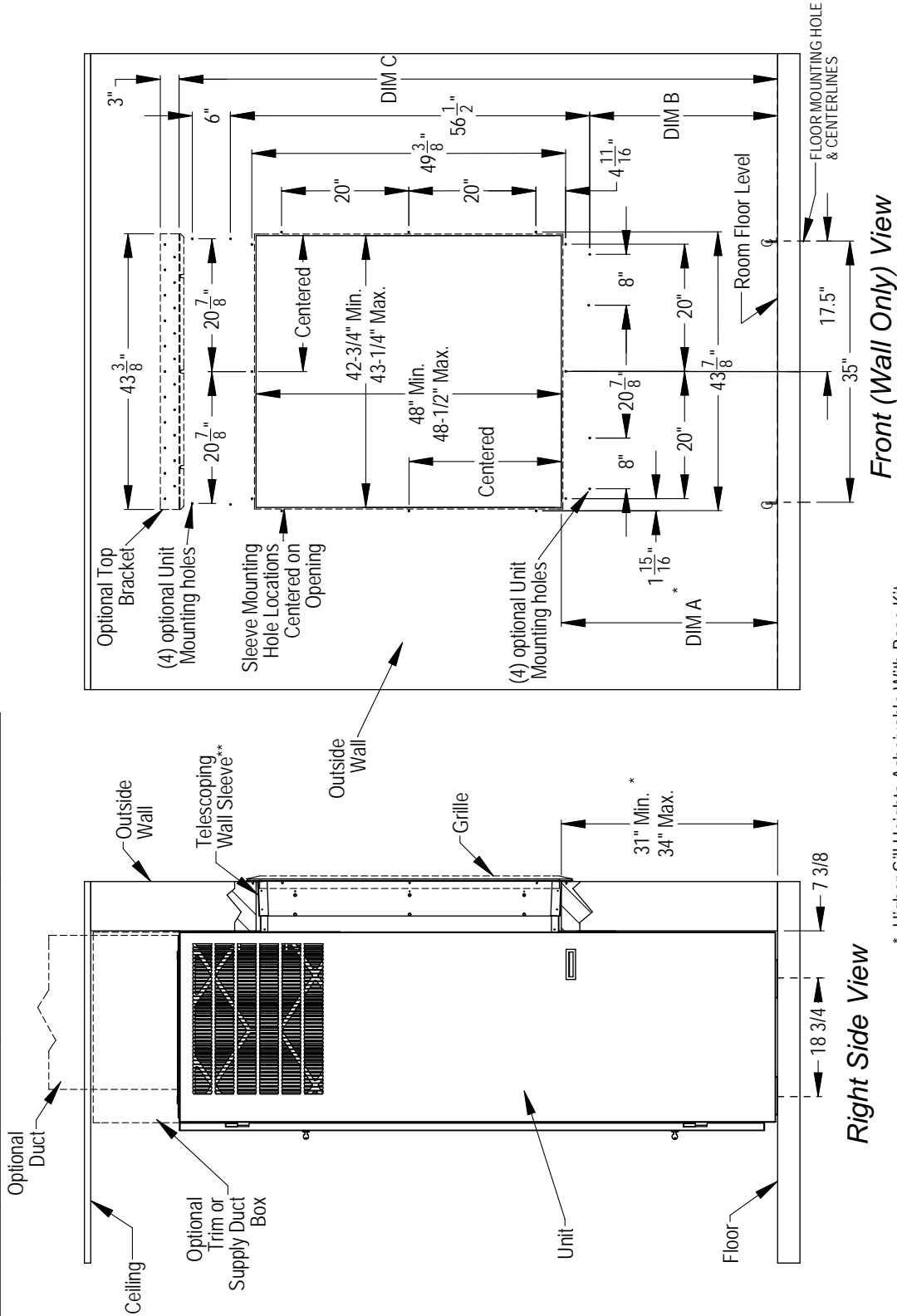

\* Higher Sill Heights Achievable With Base Kit.

\*\* Separate telescoping sleeves available for different wall thicknesses.

MIS-2918 D

*IPBDF8, IPBDFH12 AND IPBDFH18  
DUCT-FREE PLENUM BOX  
DIMENSIONS*

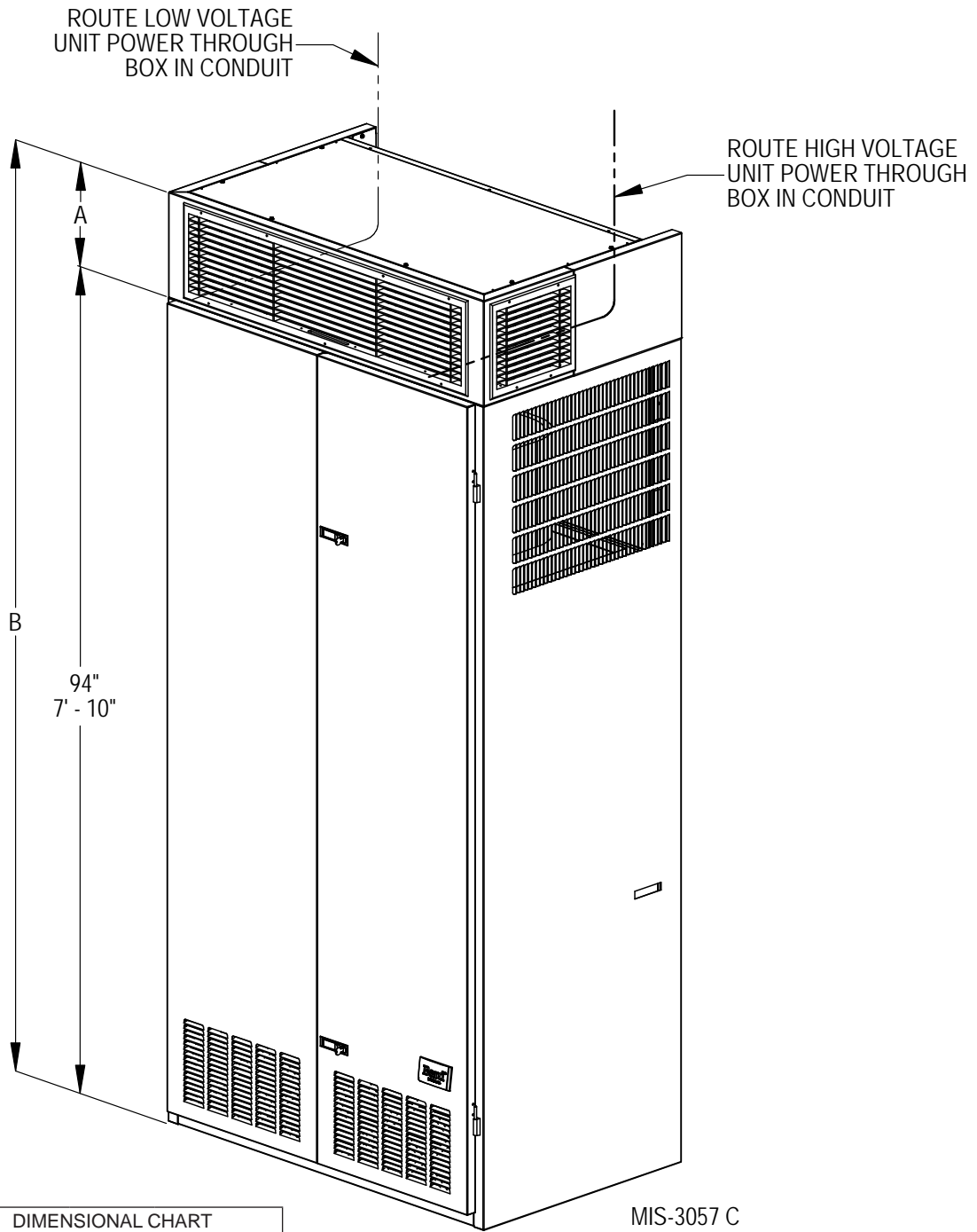

DIMENSIONAL CHART		
MODEL NO.	DIM. A	DIM. B
IPBDF8	8"	102" (8'-6")
IPBDFH12	12"	106" (8'-10")
IPBDFH18	18"	112" (9'-4")

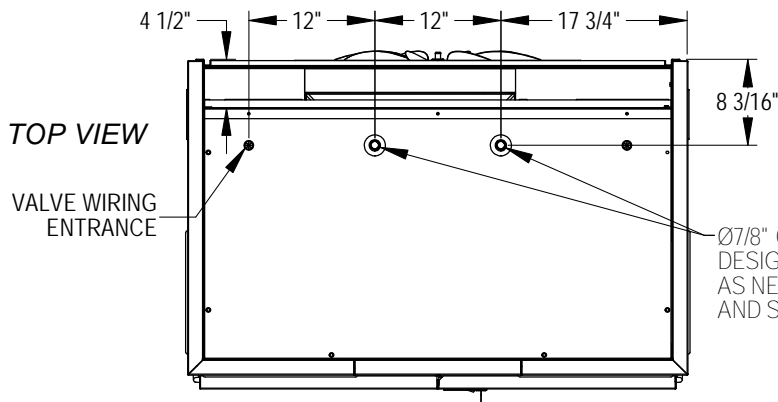

**IPBDF12HW  
DUCT-FREE  
HOT WATER COIL  
DIMENSIONS**

Ø7/8" O.D. WATER CONNECTIONS. NOT DESIGNATED AS "IN" OR "OUT". CAN BE PIPED AS NEEDED FOR EASE OF VALVE INSTALLATION AND SUPPLY/RETURN CONNECTIONS.

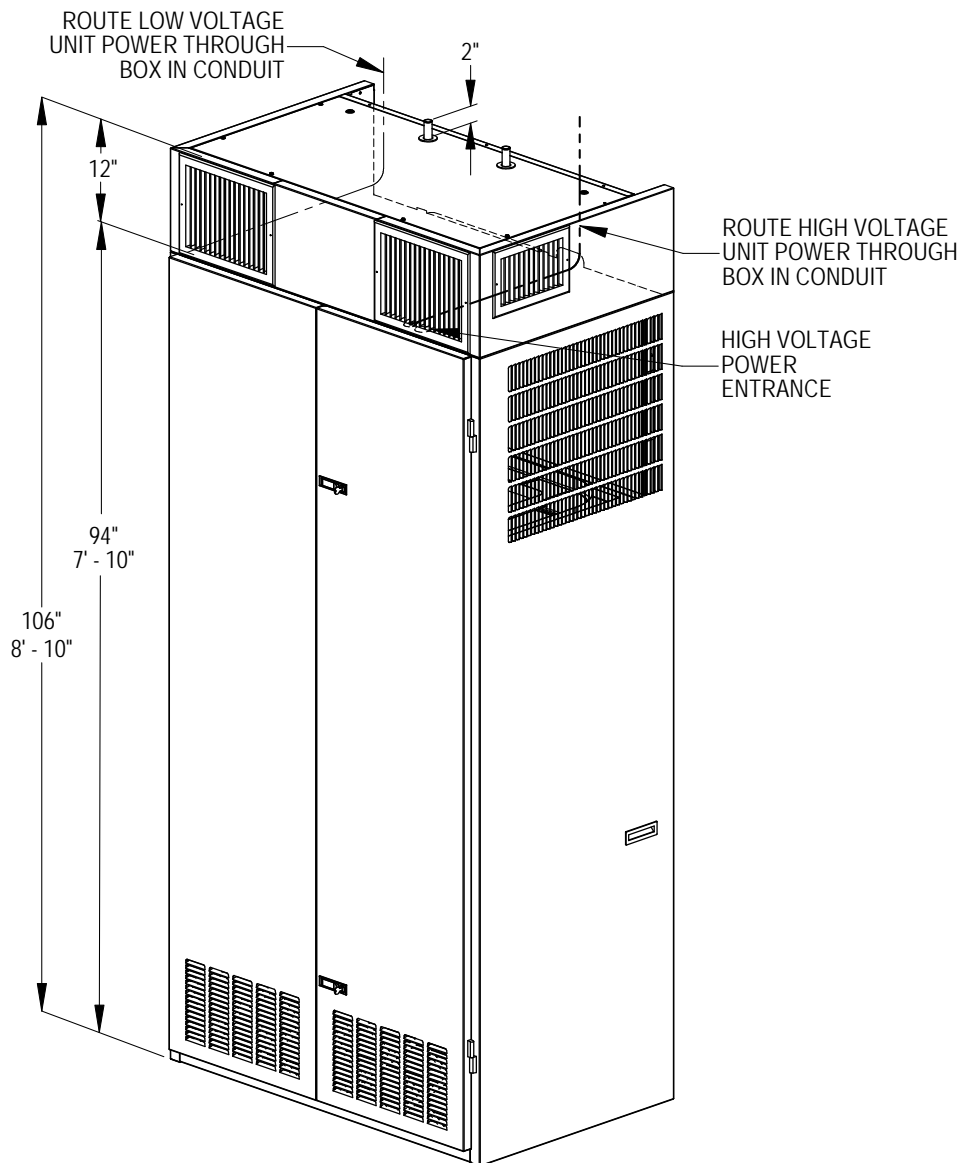

MIS-3059

# IHWC DUCTED HOT WATER COIL DIMENSIONS

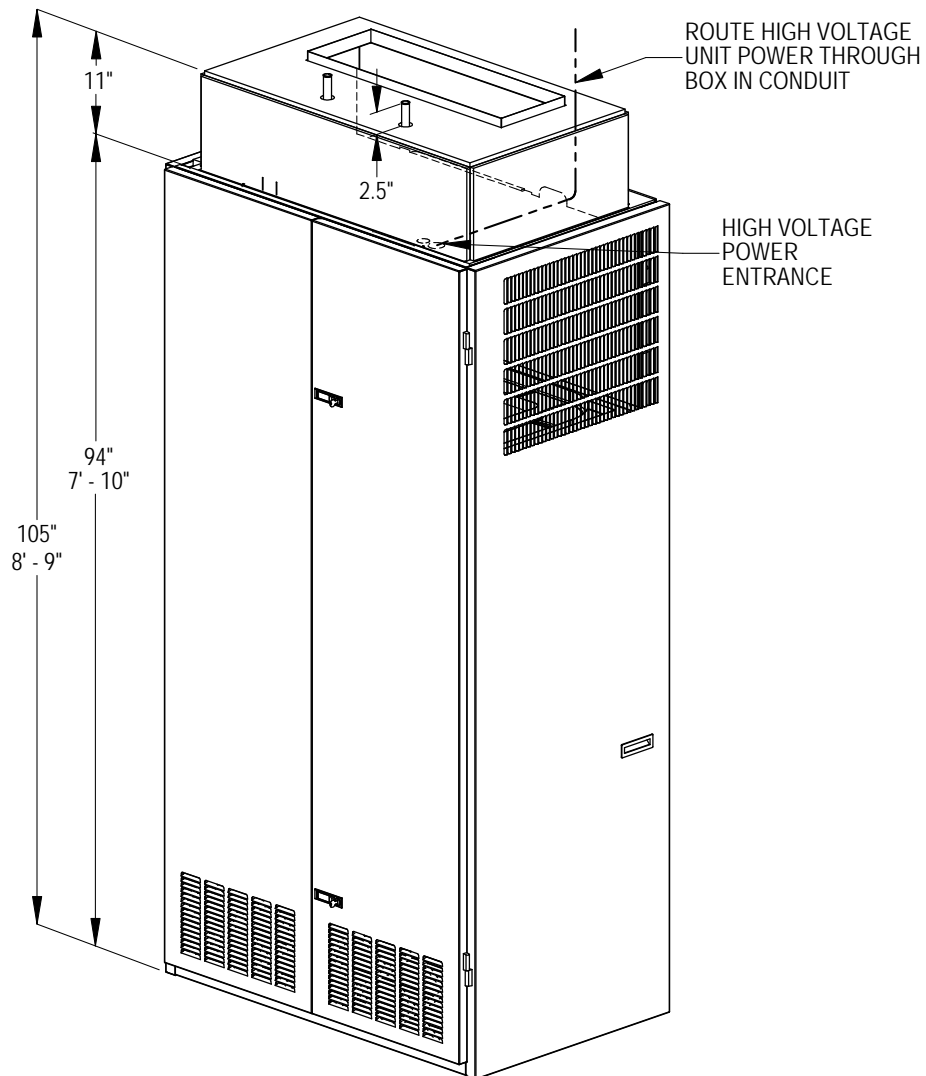
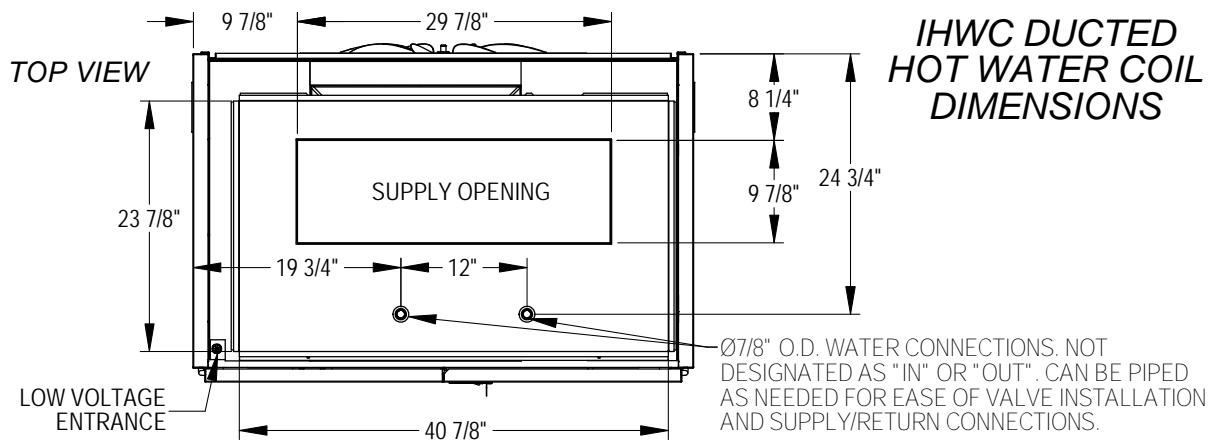

MIS-3058

# Dehumidification Performance Data

### I30A1D APPLICATION PERFORMANCE DATA

Indoor Conditions °F		Outdoor Conditions °F		System Capacity				Pounds of Water/Hour	Evaporator Airflow		Approximate Supply Air		Mode
DB/WB	%RH	DB	DB	Total	Sensible	Latent	S/T	Lbs.	CFM	DB	WB	A/C vs. Dehum.	
65/63	90	65	65	31,375	13,550	17,825	43.2%	16.8	850	50.7	50.3	A/C	
65/63	90	65	65	15,025	(1,150)	16,175	N/A	15.3	850	66.3	57.3	Dehum.	
75/62.5	50	75	75	28,125	21,600	6,525	76.8%	6.2	850	52.0	51.0	A/C	
75/62.5	50	75	75	8,900	3,650	5,250	N/A	5.0	850	71.1	58.9	Dehum.	
75/65.5	60	75	75	30,700	19,250	11,450	62.7%	10.8	850	54.5	53.5	A/C	
75/65.5	60	75	75	11,400	1,775	9,625	N/A	9.1	850	73.1	61.4	Dehum.	
75/68	70	75	75	32,100	16,725	15,375	52.1%	14.5	850	57.1	56.2	A/C	
75/68	70	75	75	13,150	(100)	13,250	N/A	12.5	850	75.1	63.6	Dehum.	
80/67	50	95	95	27,575	20,375	7,200	73.9%	6.8	850	58.1	56.7	A/C	
80/67	50	95	95	2,625	(2,975)	5,600	N/A	5.3	850	83.3	66.0	Dehum.	

### I48A1D APPLICATION PERFORMANCE DATA

Indoor Conditions °F		Outdoor Conditions °F		System Capacity				Pounds of Water/Hour	Evaporator Airflow		Approximate Supply Air		Mode
DB/WB	%RH	DB	DB	Total	Sensible	Latent	S/T	Lbs.	CFM	DB	WB	A/C vs. Dehum.	
65/63	90	65	65	53,525	22,500	31,025	42.0%	29.3	1550	51.1	50.6	A/C	
65/63	90	65	65	20,575	(4,925)	25,500	N/A	24.1	1550	68.0	58.6	Dehum.	
75/62.5	50	75	75	50,350	38,125	12,225	75.7%	11.5	1550	51.5	50.5	A/C	
75/62.5	50	75	75	12,800	3,575	9,225	N/A	8.7	1550	72.7	59.7	Dehum.	
75/65.5	60	75	75	53,750	32,975	20,775	61.3%	19.6	1550	54.6	53.7	A/C	
75/65.5	60	75	75	15,825	850	14,975	N/A	14.1	1550	74.4	62.3	Dehum.	
75/68	70	75	75	55,600	28,750	26,850	51.7%	25.3	1550	57.2	56.4	A/C	
75/68	70	75	75	17,500	(1,875)	19,375	N/A	18.3	1550	76.1	64.7	Dehum.	
80/67	50	95	95	49,250	36,350	12,900	73.8%	12.2	1550	57.6	56.4	A/C	
80/67	50	95	95	(850)	(7,300)	6,450	N/A	6.1	1550	84.6	67.2	Dehum.	

### I36A1D APPLICATION PERFORMANCE DATA

Indoor Conditions °F		Outdoor Conditions °F		System Capacity				Pounds of Water/Hour	Evaporator Airflow		Approximate Supply Air		Mode
DB/WB	%RH	DB	DB	Total	Sensible	Latent	S/T	Lbs.	CFM	DB	WB	A/C vs. Dehum.	
65/63	90	65	65	39,550	16,550	23,000	41.8%	21.7	1150	51.7	51.2	A/C	
65/63	90	65	65	17,950	(925)	18,875	N/A	17.8	1150	65.7	57.9	Dehum.	
75/62.5	50	75	75	36,775	27,750	9,025	75.5	8.5	1150	52.8	51.3	A/C	
75/62.5	50	75	75	11,000	5,925	5,075	45.7%	5.6	1150	70.9	59.3	Dehum.	
75/65.5	60	75	75	39,675	24,175	15,500	60.9%	14.6	1150	55.6	54.3	A/C	
75/65.5	60	75	75	13,000	3,075	9,925	23.7%	9.4	1150	72.5	62.0	Dehum.	
75/68	70	75	75	41,625	21,300	20,325	51.2%	19.2	1150	57.9	56.8	A/C	
75/68	70	75	75	15,900	1,050	14,850	6.6%	14.0	1150	74.1	64.0	Dehum.	
80/67	50	95	95	34,225	25,625	8,600	74.9%	8.1	1150	59.3	57.5	A/C	
80/67	50	95	95	7,625	2,575	5,050	33.8%	4.8	1150	82.8	66.7	Dehum.	

### I60A1D APPLICATION PERFORMANCE DATA

Indoor Conditions °F		Outdoor Conditions °F		System Capacity				Pounds of Water/Hour	Evaporator Airflow		Approximate Supply Air		Mode
DB/WB	%RH	DB	DB	Total	Sensible	Latent	S/T	Lbs.	CFM	DB	WB	A/C vs. Dehum.	
65/63	90	65	65	61,000	25,925	35,075	42.5%	33.1	1750	51.4	50.6	A/C	
65/63	90	65	65	18,325	(6,475)	24,800	N/A	23.4	1750	68.6	59.6	Dehum.	
75/62.5	50	75	75	58,425	44,475	13,950	76.1%	13.2	1750	52.1	50.8	A/C	
75/62.5	50	75	75	9,100	525	8,575	N/A	8.1	1750	74.8	60.8	Dehum.	
75/65.5	60	75	75	62,000	38,625	23,375	62.3%	22.1	1750	55.0	53.9	A/C	
75/65.5	60	75	75	12,150	(1,700)	13,850	N/A	13.1	1750	76.0	63.4	Dehum.	
75/68	70	75	75	65,150	33,550	31,600	51.5%	29.8	1750	57.6	56.5	A/C	
75/68	70	75	75	14,950	(4,575)	19,525	N/A	18.4	1750	77.4	65.5	Dehum.	
80/67	50	95	95	56,450	42,050	14,400	74.5%	13.6	1750	58.1	56.7	A/C	
80/67	50	95	95	(3,750)	(10,550)	6,800	N/A	6.4	1750	85.6	67.5	Dehum.	

### I42A1D APPLICATION PERFORMANCE DATA

Indoor Conditions °F		Outdoor Conditions °F		System Capacity				Pounds of Water/Hour	Evaporator Airflow		Approximate Supply Air		Mode
DB/WB	%RH	DB	DB	Total	Sensible	Latent	S/T	Lbs.	CFM	DB	WB	A/C vs. Dehum.	
65/63	90	65	65	47,475	18,875	28,600	39.8%	27.0	1300	52.0	51.5	A/C	
65/63	90	65	65	20,175	(1,925)	22,100	N/A	20.8	1300	66.3	58.2	Dehum.	
75/62.5	50	75	75	42,775	31,675	11,100	74.1%	10.5	1300	52.7	51.0	A/C	
75/62.5	50	75	75	11,950	5,075	6,875	42.5%	6.5	1300	71.3	59.5	Dehum.	
75/65.5	60	75	75	45,750	27,750	18,000	60.7%	17.0	1300	55.4	54.0	A/C	
75/65.5	60	75	75	15,325	2,625	12,700	17.1%	12.0	1300	73.1	62.0	Dehum.	
75/68	70	75	75	48,075	24,300	23,775	50.5%	22.4	1300	57.8	56.7	A/C	
75/68	70	75	75	17,675	250	17,425	1.4%	16.4	1300	74.8	64.2	Dehum.	
80/67	50	95	95	40,375	29,575	10,800	73.3%	10.2	1300	59.2	57.2	A/C	
80/67	50	95	95	325	(3,900)	4,225	N/A	4.0	1300	82.8	66.8	Dehum.	

## I30A-I60A Indoor Sound Data at 10 Feet

1. dBA @ 10 feet, Values recorded in Bard Manufacturing Company, Inc. Sound Lab Facility.
2. Actual field results may vary with classroom design and construction.
3. Integrated values calculated per ANSI/ASA S12.60-2009 / Part 2, Section 5.2.2.1, Table 2 Triple Mode Type 3 HVAC System Duty Cycles: Ventilation 58%, Part Load 25%, Full Load 17%
4. Integrated Sound Values are also applicable for use in learning spaces for CHPS and LEED Schools: EQ Prerequisite 3 - Minimum Acoustical Performance, OPTION 1. Using methods prescribed in ANSI S12.60, classrooms must achieve a maximum background noise level of 45 dBA.

Vent: ERV		IPBDFH-12 Duct Free 12" Plenum Box				Ducted			
Model	Operation	ERV Off	ERV @ 150	ERV @ 375	ERV @ 450	ERV Off	ERV @ 150	ERV @ 375	ERV @ 450
I30A	<i>Integrated</i>	33.7	34.0	39.3	40.0	33.6	34.0	39.0	40.1
I36A	<i>Integrated</i>	37.7	38.0	40.7	41.7	36.5	37.1	41.7	42.7
I42A	<i>Integrated</i>	38.6	40.7	41.3	41.9	39.4	39.3	41.8	42.4
I48A	<i>Integrated</i>	39.0	39.0	39.7	39.8	39.8	39.8	40.3	40.6
I60A	<i>Integrated</i>	41.4	41.3	41.6	41.6	41.3	41.3	41.8	41.9

### Factory Setting(s) shaded in Gray

Vent: CRV		IPBDFH-12 Duct Free 12" Plenum Box					Ducted				
Model	Operation	CRV Off	CRV @ 300	CRV @ 375	CRV @ 450	CRV @ 525	CRV Off	CRV @ 300	CRV @ 375	CRV @ 450	CRV @ 525
I30A	<i>Integrated</i>	34.4	36.0	38.2	40.6	42.1	34.6	36.6	38.1	40.6	42.0
I36A	<i>Integrated</i>	37.0	38.5	40.3	42.4	43.9	37.2	40.2	39.2	42.2	44.0
I42A	<i>Integrated</i>	39.2	39.8	41.0	42.5	43.5	39.9	40.4	41.1	42.8	43.5
I48A	<i>Integrated</i>	40.2	40.7	41.5	43.0	44.2	41.0	40.7	42.2	43.4	44.1
I60A	<i>Integrated</i>	44.0	44.3	44.6	45.4	45.9	43.5	43.7	44.1	44.8	45.5

## Outdoor Sound Data at 10 Feet

Model	I30A	I36A	I42A	I48A	I60A
	63.7	66.6	67.3	67.9	67.8

# I-TEC 2-Stage Air Source Air Conditioners Model Number Nomenclature

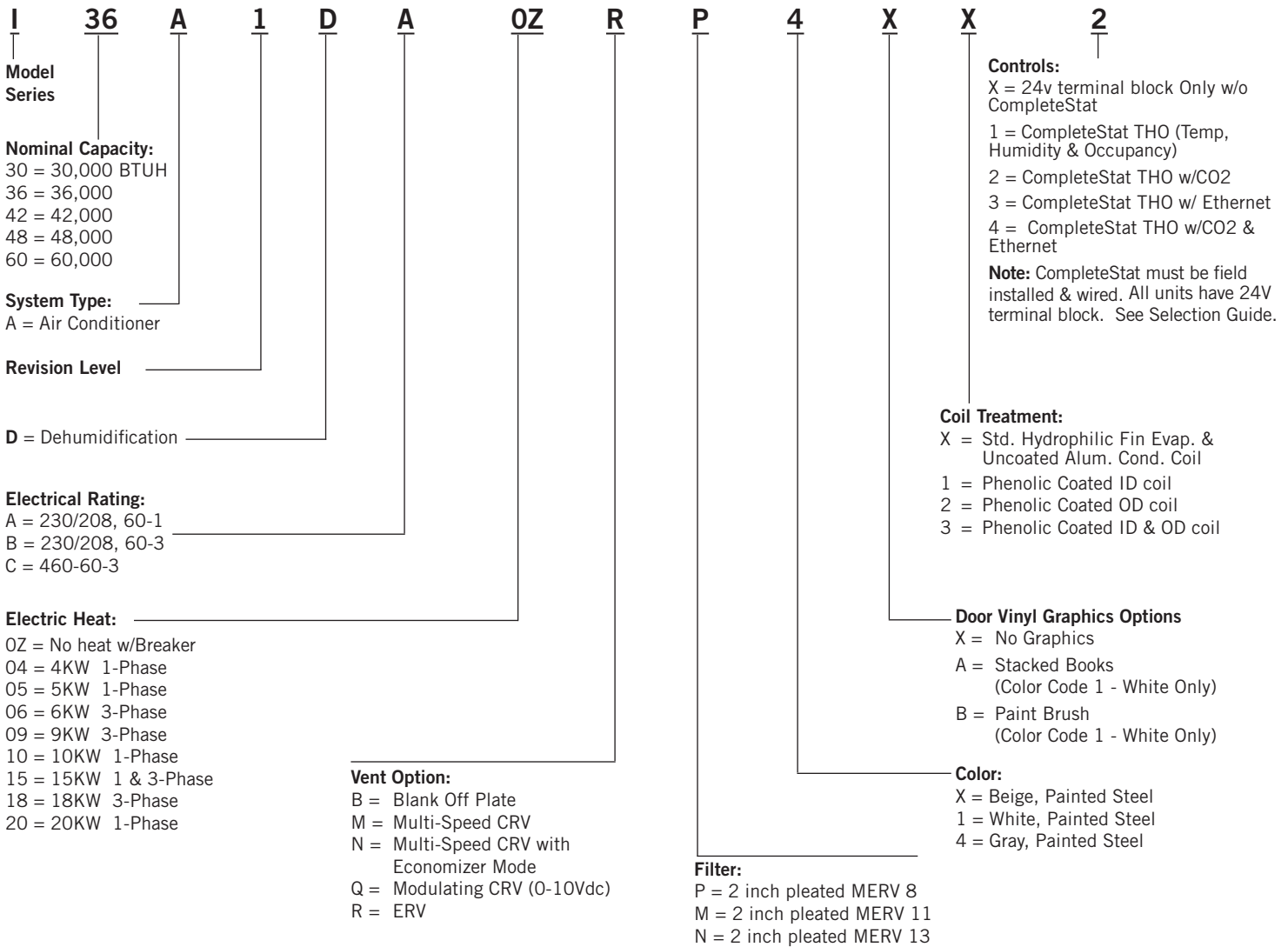

CompleteStat™ Selection Guide						
Vent Type	Type of Vent Control	BACnet ① Communication	Ethernet ② Connection	Control Code	Description	CompleteStat Part Number
None	N/A	Yes	No	1	CompleteStat THO (Temp, Humidity & Occupancy)	CS9B-THOA
	N/A	Yes	Yes	3	CompleteStat THO w/Ethernet	CS9BE-THOA
CRV	On/Off	Yes	No	1	CompleteStat THO (Temp, Humidity & Occupancy)	CS9B-THOA
	Demand ③	Yes	No	2	CompleteStat THO w/CO2	CS9B-THOCA
	On/Off	Yes	Yes	3	CompleteStat THO w/Ethernet	CS9BE-THOA
	Demand ③	Yes	Yes	4	CompleteStat THO w/CO2 & Ethernet	CS9BE-THOCA
ERV	On/Off	Yes	No	1	CompleteStat THO (Temp, Humidity & Occupancy)	CS9B-THOA
	Demand ③	Yes	No	2	CompleteStat THO w/CO2	CS9B-THOCA
	On/Off	Yes	Yes	3	CompleteStat THO w/Ethernet	CS9BE-THOA
	Demand ③	Yes	Yes	4	CompleteStat THO w/CO2 & Ethernet	CS9BE-THOCA

① BACnet is standard - all versions, shielded twisted pair.  
 ② These models also have CAT 5 port for ease of networking in addition to twisted pair terminals.  
 ③ Demand control for ventilation is ON/OFF based on CO2 set-point.  
 If modulating mode for ERV is required, use – THO controller plus 8403-067 CO2 controller with modulating output.



Bard Manufacturing Company, Inc.  
 Bryan, Ohio 43506  
 www.bardhvac.com

Due to our continuous product improvement policy,  
 all specifications subject to change without notice.

Form No.  
**S3464**  
 August 2020

Supersedes: S3464-918