



LF
Series



AIR-COOLED CONDENSER CHILLERS



Features:

- Air-cooled condenser chillers with capacities from 4-55 tons
- Staged or variable capacity R-410A scroll compressors for load matching cooling and improved part load efficiency
- High efficiency microchannel condenser coils
- Shell and tube or brazed plate heat exchangers
- High efficiency VFD controlled or ECM driven variable speed condenser fans
- Factory engineered and installed pumping packages
- Service vestibule with double wall rigid polyurethane foam panel construction
- Service access door with full length stainless steel piano hinges and lockable handles
- Factory installed DDC controller compatible with BACnet®, Modbus®, and LonTalk® protocols

Application Flexibility
Minimizes Installation Time and Reduces Cost

- *Factory Installed Pumping Packages*
- *Variable Capacity Scroll Compressors*
- *Easy to Install and Service*
- *Factory Installed Controls*

LF Series Air-Cooled Chillers

AAON LF Series chillers are designed for premium performance and superior serviceability. The chiller can be provided with factory engineered and installed pumping packages, eliminating the need for a mechanical room. For improved part load efficiency and consistent leaving water temperature, LF Series chillers are available with variable capacity scroll compressors. Each LF Series chiller is factory tested to ensure proper operation once installed.



Microchannel condenser coils are more efficient, lighter, and use less refrigerant than traditional fin and tube condenser coils.

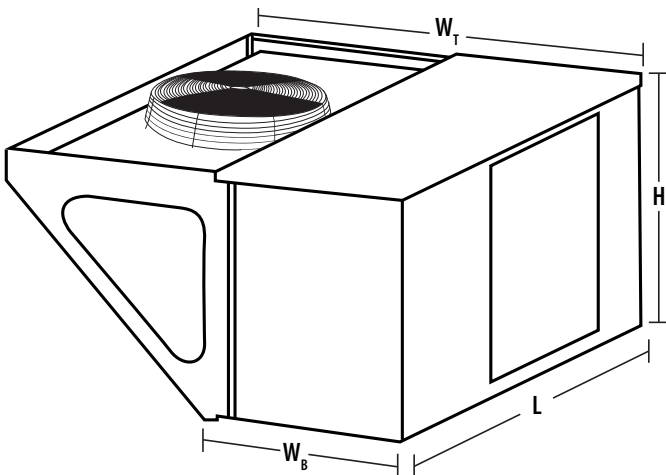

Superior Features

- Staged or 10-100% variable capacity R-410A scroll compressors are available to improve part load efficiency and provide load matching cooling.
- Two inch double wall rigid polyurethane foam panel construction makes the cabinet more rigid and resistant to damage and attenuates radiated compressor and pump sounds.
- Scroll compressors include rubber isolation mounts that minimize vibration.
- Access doors with full length stainless steel hinges and lockable handles provide reliability and make the unit easily serviceable.
- Control and compressor service compartment is isolated from the outdoor air stream for easy service and maintenance.
- Lifting lugs and rigid base pan design with forklift slots for easy job site handling.
- Corrosion resistant paint exceeds a 2,500 hour salt-spray test.
- Run test report, color-coded wiring diagram and Installation, Operation, and Maintenance manual with startup form are provided in the control compartment.
- High efficiency air-cooled microchannel coils maximize performance of the chiller.
- Crankcase heaters prevent liquid from settling in the compressors during low ambient conditions.
- Shell and tube or brazed plate heat exchangers provide energy efficient cooling.

Premier Options

- VFD controlled or ECM driven condenser fans create a wider ambient temperature operating range, increase part load efficiency, and minimize radiated fan sound.
- Polymer e-coated condenser coils are available to extend the life of the coils and protect them in corrosive environments.
- Multiple factory engineered and installed pumping packages that eliminate interior mechanical room building space.
- Flooded condenser head pressure control allows mechanical cooling at low ambient temperatures down to 0°F.
- Auxiliary electric heating can be provided in the service vestibule.
- Glycol chillers for refrigeration and low ambient applications.
- 5 year non-prorated compressor warranty.

Application Flexibility

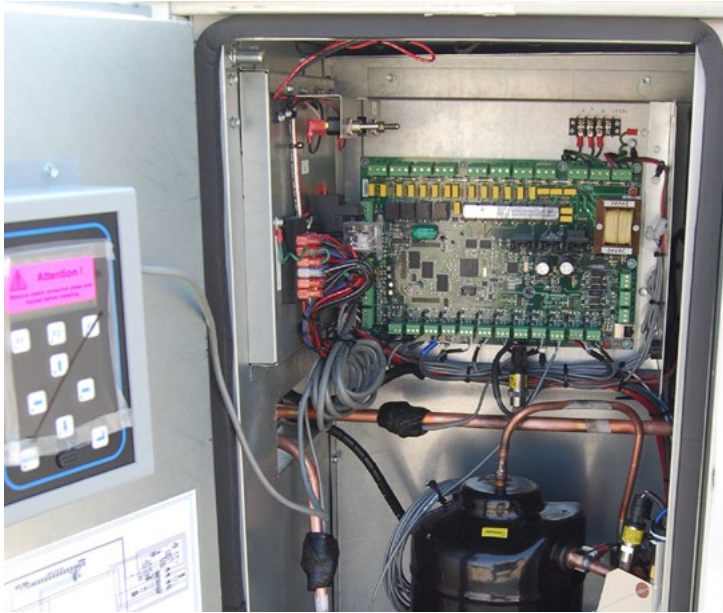

Compressor and control service compartment reduces installation and service time.

Air-Cooled Condenser

LF Series chillers are designed with microchannel condenser coils that increase the effective surface area for heat transfer, leading to a more efficient chiller. Microchannel condenser coils are also up to 30% lighter and use less refrigerant than traditional fin and tube condenser coils.

Heat Exchangers

Factory installed and insulated shell and tube heat exchangers or factory installed and insulated brazed plate heat exchangers are available with LF Series chillers.

Factory Installed Pumping Packages

Pumping packages that include a pump, butterfly valves, strainers, and ball valves are available. Grooved end piping and fittings are provided in all LF Series chillers. AAONECat selection software allows quick and easy selection of proper pumping package components and includes pump performance curves and piping diagram.

Variable Capacity Scroll Compressors

LF Series chillers are available with 10-100% variable capacity scroll compressors that modulate capacity. This allows the system to maintain consistent leaving water temperatures at all operating conditions. During part load operation, reducing compressor capacity increases part load efficiency and saves valuable system operating costs.

AAON Chillers

AAON LF Series chillers are available from 4-55 tons, AAON LN Series chillers are available from 45-140 tons, and AAON LZ Series chillers are available from 45-540 tons. LF and LN Series chillers are available with R-410A scroll compressors. LZ Series chillers are available from 45-478 tons with R-410A scroll compressors. LZ Series chillers are also available from 90-540 tons with Turbocor R-134a centrifugal compressors.

LF Model	Cabinet	Width Base	Width Top	Height	Length
004	A	32	69	44	85
005					
007					
009					
008	B	45	80	51	90
010					
011					
013					
014					
015	C	50	87	60	111
017					
022					
024					
021					
026					
031	D	143	176	68	80
042					
048					
055					

All dimensions are in inches.

AAON Environmentally Friendly HVAC Product Family

**Custom & Cataloged
Air Handling Units** ■
(800-200,000+ cfm)

Condensers & Condensing Units ■
(2-230 tons)

**Chillers (Air-Cooled &
Evaporative-Cooled)** ■
(4-540 tons)

Rooftop Units ■
(2-240 tons)

Outdoor Equipment Rooms ■
(Chillers, Boilers & Pumps)

Self-Contained Units ■
(3-70 tons)

Residential Systems ■
(2-5 tons)

Geothermal & WSHP Units ■
(2-230 tons)

Air-Source Heat Pumps ■
(2-230 tons)

Heating and Cooling Coils ■
(Booster, Hydronic, & DX)

Fluid Coolers ■
(50-450 tons)

Heating and Cooling *for...*

Auditoriums
Convenience Stores
Health Clubs
Healthcare Facilities
Homes
Lodgings
Manufacturing
Museums & Libraries
Natatoriums
Office Buildings
Restaurants
Retail Stores
Schools
Supermarkets



Defining Quality. Building Comfort.

2425 S. Yukon Ave.
Tulsa, OK 74107-2728
www.AAON.com

It is the intent of AAON to provide accurate and current product information. However, in the interest of product improvement, AAON reserves the right to change pricing, specifications, and/or design of its product without notice, obligation, or liability. Copyright © AAON, all rights reserved throughout the world. AAON® and AAONAIRE® are registered trademarks of AAON, Inc., Tulsa, OK.